

SONY

DIGITAL CASSETTE VTR

DVR-1000

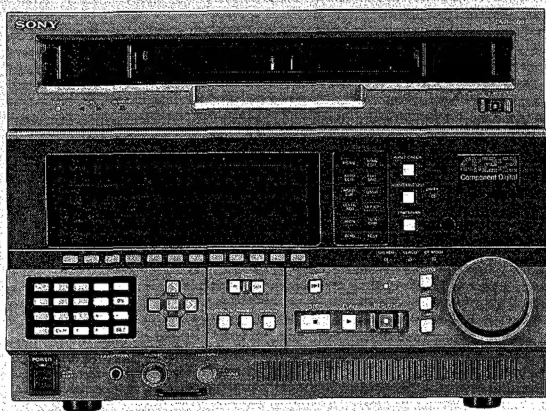

4:2:2

Component Digital

MAINTENANCE MANUAL

Volume 1 2nd Edition

Serial No. 32101 and Higher (UC)

Serial No. 32201 and Higher (EK)

SAFETY CHECK-OUT

After correcting the original service problem, perform the following safety checks before releasing the set to the customer:

Check the metal trim, "metallized" knobs, screws, and all other exposed metal parts for AC leakage. Check leakage as described below.

LEAKAGE TEST

The AC leakage from any exposed metal part to earth ground and from all exposed metal parts to any exposed metal part having a return to chassis, must not exceed 3.5mA. Leakage current can be measured by any one of three methods.

1. A commercial leakage tester, such as the Simpson 229 or RCA WT-540A. Follow the manufacturers' instructions to use these instruments.
2. A battery-operated AC milliammeter. The Data Precision 245 digital multimeter is suitable for this job.
3. Measuring the voltage drop across a resistor by means of a VOM or battery-operated AC voltmeter. The "limit" indication is 5.25V so analog meters must have an accurate low-voltage scale. The Simpson 250 and Sanwa SH-63Trd are examples of a passive VOM that is suitable. Nearly all battery operated digital multimeters that have a 20V AC range are suitable. (See Fig. A)

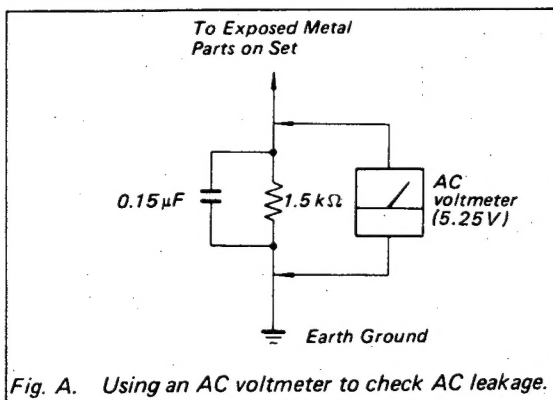

Fig. A. Using an AC voltmeter to check AC leakage.

このマニュアルに記載されている事柄の著作権は当社にあり、説明内容は機器購入者の使用を目的としています。従って、当社の許可なしに無断で複写したり、説明内容(操作、保守等)と異なる目的で本マニュアルを使用することを禁止します。

The material contained in this manual consists of information that is the property of Sony Corporation and is intended solely for use by the purchasers of the equipment described in this manual.

Sony Corporation expressly prohibits the duplication of any portion of this manual or the use thereof for any purpose other than the operation or maintenance of the equipment described in this manual without the express written permission of Sony Corporation.

Le matériel contenu dans ce manuel consiste en informations qui sont la propriété de Sony Corporation et sont destinées exclusivement à l'usage des acquéreurs de l'équipement décrit dans ce manuel.

Sony Corporation interdit formellement la copie de quelque partie que ce soit de ce manuel ou son emploi pour tout autre but que des opérations ou entretiens de l'équipement à moins d'une permission écrite de Sony Corporation.

Das in dieser Anleitung enthaltene Material besteht aus Informationen, die Eigentum der Sony Corporation sind, und ausschließlich zum Gebrauch durch den Käufer der in dieser Anleitung beschriebenen Ausrüstung bestimmt sind.

Die Sony Corporation untersagt ausdrücklich die Vielfältigung jeglicher Teile dieser Anleitung oder den Gebrauch derselben für irgendeinen anderen Zweck als die Bedienung oder Wartung der in dieser Anleitung beschriebenen Ausrüstung ohne ausdrückliche schriftliche Erlaubnis der Sony Corporation.

TABLE OF CONTENTS

Volume-1

1. INSTALLATION

| | | |
|--------|---|------|
| 1-1. | Unpacking and Repacking | 1-1 |
| 1-2. | Accessories Supplied | 1-2 |
| 1-3. | Power Requirement | 1-2 |
| 1-3-1. | Capacity of AC Power Source | 1-2 |
| 1-3-2. | Power Cord | 1-2 |
| 1-3-3. | Setting Voltage Selector | 1-3 |
| 1-3-4. | Ventilation/Heat Sink | 1-3 |
| 1-4. | Installation Conditions | 1-3 |
| 1-5. | Installation Space | 1-4 |
| 1-6. | Installing the Function Control Panel | 1-6 |
| 1-7. | Rack-mounting | 1-8 |
| 1-8. | Input/Output Interface | 1-9 |
| 1-8-1. | Matching Connectors and Cables | 1-9 |
| 1-8-2. | Input/Output Signal of the Connectors | 1-9 |
| 1-9. | Initial Setting of Switches and Jumpers | 1-12 |
| 1-9-1. | Changing the Line Output Impedances | 1-12 |
| 1-9-2. | Changing the Line Input Impedances | 1-13 |

2. SERVICE INFORMATION

| | | |
|--------|---|------|
| 2-1. | Principal Component Location | 2-1 |
| 2-2. | Cabinet Removal | 2-7 |
| 2-3. | Notes on Power Unit | 2-8 |
| 2-3-1. | Primary Circuit & Electric Shock | 2-8 |
| 2-3-2. | The Power Supply Removal | 2-8 |
| 2-3-3. | Checking the MD-43/PD-36/MB-137 Boards and Adjusting the Power Supply | 2-9 |
| 2-3-4. | The PS-138/CT-74/RE-32 Boards Check | 2-10 |
| 2-4. | Extracting/Inserting Plug-in Boards | 2-12 |
| 2-5. | Notes on Repair Parts | 2-12 |
| 2-5-1. | Notes on Repair Parts | 2-12 |
| 2-5-2. | Replacement Procedure of Chip Parts | 2-13 |
| 2-5-3. | Replacing the Backup Battery | 2-14 |
| 2-5-4. | Replacing Flexible Wire (4P, 26P) | 2-15 |
| 2-5-5. | Replacing the EL Panel (Function Control Panel) | 2-15 |
| 2-5-6. | Servicing Board in Head Drum | 2-15 |
| 2-6. | Method of Removing Cassette Tape When Either it Cannot be Ejected or Cassetteup Compartment does not Rise | 2-16 |
| 2-7. | Alignment Tape DR-5-1A and DR-5-1B | 2-18 |
| 2-8. | Maintenance Tools/Fixtures | 2-19 |
| 2-9. | Method of Calibration of the Guide S5/T6 Zenith Check Tool | 2-26 |
| 2-9-1. | Calibration of the Guide S5 Zenith Check Tool | 2-26 |
| 2-9-2. | Calibration of the Guide T6 Zenith Check Tool | 2-27 |

| | | |
|---------|--|------|
| 2-10. | Function of Switches, Jumpers and Leds | 2-28 |
| 2-10-1. | RE-15 Board | 2-28 |
| 2-10-2. | AE-05 Board | 2-28 |
| 2-10-3. | SP-01 Board | 2-28 |
| 2-10-4. | SY-69/124 Board | 2-29 |
| 2-10-5. | LO-05 Board | 2-29 |
| 2-10-6. | TR-40 Board | 2-29 |
| 2-10-7. | IF-138 Board | 2-29 |
| 2-10-8. | CP-106 Board | 2-29 |

3. TEST MENU

| | | |
|--------|---|------|
| 3-1. | Selection of Test Menu | 3-1 |
| 3-2. | Panel Menu | 3-1 |
| 3-3. | RF Menu | 3-2 |
| 3-3-1. | RF Menu Flowchart | 3-2 |
| 3-3-2. | Selection of RF Menu | 3-3 |
| 3-3-3. | Selection of the RF Parameter Adjustment Mode | 3-4 |
| 3-3-4. | Selection of PB EQUALIZER Adjustment Menu | 3-5 |
| 3-3-5. | Selection of REC DRIVE Adjustment Menu | 3-6 |
| 3-3-6. | Writing of Control Data | 3-6 |
| 3-4. | Checker Menu | 3-7 |
| 3-4-1. | Explanation of Keys | 3-7 |
| 3-4-2. | List of Commands | 3-8 |
| 3-4-3. | Examples of Command Usages | 3-9 |
| 3-4-4. | Test Mode | 3-12 |
| 3-4-5. | Repeat Data Check | 3-17 |
| 3-4-6. | Mechanical Check Mode | 3-20 |
| 3-4-7. | S/T Reel Test Mode | 3-21 |
| 3-5. | NOVRAM Data | 3-24 |
| 3-6. | Method for Individual Resetting of Operation Time | 3-26 |

4. THEORY OF OPERATION

| | | |
|--------|--------------------------------------|--------|
| 4-1. | Outline | 4-1-1 |
| 4-1-1. | Tape Pattern | 4-1-2 |
| 4-1-2. | Cassette Tape | 4-1-3 |
| 4-1-3. | Tape Transport | 4-1-4 |
| 4-1-4. | Longitudinal Track | 4-1-5 |
| 4-2. | Audio Signal System (CUE/TC/CTL) | 4-2-1 |
| 4-2-1. | Outline | 4-2-1 |
| 4-2-2. | Serial Interface | 4-2-2 |
| 4-2-3. | Line Input Transformer | 4-2-2 |
| 4-2-4. | CUE Recording/Playback Circuit | 4-2-3 |
| 4-2-5. | Time Code Recording/Playback Circuit | 4-2-8 |
| 4-2-6. | CTL Recording/Playback Circuit | 4-2-11 |
| 4-2-7. | Crosstalk Canceler | 4-2-12 |
| 4-2-8. | Erase Amplifier | 4-2-13 |

| | | |
|---------|--|--------|
| 4-2-9. | Audio Monitor Output Amplifier | 4-2-14 |
| 4-2-10. | Waveform Monitor Output Signal Select Circuit | 4-2-15 |
| 4-2-11. | Line Output Amplifier | 4-2-16 |
| 4-2-12. | Muting Circuit | 4-2-16 |
| 4-3. | RF Signal System | 4-3-1 |
| 4-3-1. | Recording Drive Amplifier | 4-3-1 |
| 4-3-2. | Playback Equalizer | 4-3-4 |
| 4-3-3. | ADV/CONFI Switching Signal Generator | 4-3-6 |
| 4-3-4. | Envelope Output Voltage Converter Circuit | 4-3-6 |
| 4-4. | Servo System | 4-4-1 |
| 4-4-1. | Outline of Servo System | 4-4-1 |
| 4-4-2. | SP-01 Board | 4-4-3 |
| 4-4-3. | CD-35 Board | 4-4-14 |
| 4-4-4. | RS-23 Board | 4-4-29 |
| 4-4-5. | Sensor Section | 4-4-34 |
| 4-4-6. | MD-43 Board | 4-4-37 |
| 4-4-7. | PD-36 Board | 4-4-46 |
| 4-5. | System Control System | 4-5-1 |
| 4-5-1. | Outline of System Control System | 4-5-1 |
| 4-5-2. | Outline of Hardware | 4-5-2 |
| 4-5-3. | Outline of Software | 4-5-2 |
| 4-5-4. | SY-69 Board | 4-5-4 |
| 4-6. | Function Control Panel | 4-6-1 |
| 4-6-1. | CP-106 Board | 4-6-1 |
| 4-6-2. | SW-157 Board (SW-158 Board) | 4-6-3 |
| 4-6-3. | PS-139 Board | 4-6-4 |
| 4-6-4. | EL Display Unit | 4-6-5 |
| 4-6-5. | Jog Dial (DET-3 Board) | 4-6-5 |
| 4-6-6. | Rotary Encoder (RE-44 Board) | 4-6-6 |
| 4-6-7. | Self Diagnosis when the Power is Switched ON | 4-6-6 |
| 4-7. | Interface System | 4-7-1 |
| 4-7-1. | IF-138 Board | 4-7-1 |
| 4-7-2. | GPIB Interface | 4-7-2 |
| 4-7-3. | RS422 Interface | 4-7-2 |
| 4-7-4. | PR-87 Board | 4-7-2 |
| 4-8. | Power Supply Section | 4-8-1 |
| 4-8-1. | Power Supply Specifications | 4-8-1 |
| 4-8-2. | Circuit Outline | 4-8-2 |
| 4-8-3. | Primary Side Circuit | 4-8-2 |
| 4-8-4. | Secondary Circuit | 4-8-9 |

5. PERIODICAL INSPECTION AND MAINTENANCE

| | | |
|--------|---------------------------------|------|
| 5-1. | Periodical Inspection | 5-1 |
| 5-2. | Maintenance | 5-5 |
| 5-2-1. | Cleaning | 5-5 |
| 5-2-2. | Tracking Check | 5-13 |
| 5-2-3. | Head Projection Check | 5-14 |
| 5-2-4. | Apply Grease and Oil | 5-17 |

6. PARTS REPLACEMENT AND ADJUSTMENT

| | | |
|---------|--|------|
| 6-1. | Scanner Assembly | 6-1 |
| 6-1-1. | Replacement of the Scanner Assembly | 6-1 |
| 6-1-2. | Adjustment Made after Replacement of the Scanner Assembly | 6-4 |
| 6-2. | Drum Assembly | 6-5 |
| 6-2-1. | Replacement of the Drum Assembly | 6-5 |
| 6-2-2. | Adjustment Made After the Replacement of the Drum Assembly | 6-7 |
| 6-3. | Replacement of the Shaft Ground Bushing | 6-8 |
| 6-4. | Replacement of the Cassette Compartment | 6-9 |
| 6-5. | Replacement of Components of the Cassette Compartment | 6-15 |
| 6-5-1. | Replacement of the Motor | 6-16 |
| 6-5-2. | Replacement of Gear A | 6-17 |
| 6-5-3. | Replacement of Gear C | 6-18 |
| 6-5-4. | Replacement of the Stopper Roller | 6-19 |
| 6-5-5. | Replacement of the Cassette Compartment Lid | 6-20 |
| 6-6. | Replacement of the Reel Motor | 6-21 |
| 6-7. | Replacing the Brake Arm and the Plunger Solenoid | 6-25 |
| 6-8. | Replacement of the Reel Motor Shift Components | 6-27 |
| 6-8-1. | Replacement of the Timing Pulley | 6-28 |
| 6-8-2. | Replacement of Spur Gear (A or B) | 6-29 |
| 6-8-3. | Replacement of the Worm | 6-32 |
| 6-9. | Replacement of the S Guide Block | 6-33 |
| 6-10. | Replacement of the S Drawer Slider | 6-35 |
| 6-11. | Replacement of the Tension Regulator | 6-37 |
| 6-12. | Replacement of the Full Erase Head | 6-39 |
| 6-13. | Mechanical Components for Threading | 6-40 |
| 6-13-1. | Adjustment Made after the Replacement of the Mechanical Components for Threading | 6-40 |
| 6-13-2. | Replacement of Link Wheels S/T | 6-45 |
| 6-13-3. | Replacement of Components of the Drive Shaft Assembly | 6-46 |
| 6-13-4. | Replacement of Gears H and G | 6-47 |
| 6-13-5. | Replacement of Components of the Gear Box Assembly | 6-47 |
| 6-14. | Capstan Motor | 6-49 |
| 6-14-1. | Replacement of the Capstan Motor | 6-49 |
| 6-14-2. | Adjustment to be Made after Replacing the Capstan Motor | 6-52 |
| 6-15. | Pinch Roller | 6-53 |
| 6-15-1. | Adjustments Made after Replacing the Parts of the Pinch Roller | 6-53 |
| 6-15-2. | Replacement of the Pinch Roller | 6-63 |
| 6-15-3. | Replacement of the Pinch Block | 6-64 |
| 6-15-4. | Replacement of the Components of the Pinch Roller | 6-65 |

| | | |
|----------|--|------|
| 6-15-5. | Replacement of the Limiter Link | 6-66 |
| 6-15-6. | Replacement of the Arm Stopper | 6-67 |
| 6-15-7. | Replacement of the Arm | 6-68 |
| 6-15-8. | Replacing the PS Guide Assembly | 6-69 |
| 6-15-9. | Replacement of the T Roller Base | 6-71 |
| 6-15-10. | Replacement of the T6 Guide Roller | 6-73 |
| 6-16. | Stationary Head | 6-74 |
| 6-16-1. | Replacement of the Stationary Head | 6-74 |
| 6-16-2. | Adjustment to be Made after Replacing the Stationary Head | 6-75 |

7. GENERAL INFORMATION FOR ALIGNMENT

| | | |
|------|---|-----|
| 7-1. | Index of Alignment Components | 7-1 |
| 7-2. | Equipment Required | 7-2 |
| 7-3. | Connections | 7-3 |
| 7-4. | Initial Setting of the Switches/Jumpers | 7-4 |

8. POWER SUPPLY ALIGNMENT

| | | |
|------|---|-----|
| 8-1. | Power Supply Alignment Sequence | 8-2 |
| 8-2. | +5 V Voltage Adjustment | 8-3 |
| 8-3. | Series Regulator Voltage Adjustment | 8-4 |
| 8-4. | Series Regulator Current Limiter Adjustment | 8-4 |
| 8-5. | +22 V Voltage Adjustment | 8-5 |
| 8-6. | Motor Drive Output Voltage Adjustment | 8-5 |

9. TAPE PATH SYSTEM ALIGNMENT

| | | |
|--------|---|------|
| 9-1. | Flowchart for Adjustment | 9-1 |
| 9-2. | Tape Path Adjustment | 9-2 |
| 9-3. | Tape Tension Adjustment | 9-7 |
| 9-4. | Tape Speed Adjustment | 9-11 |
| 9-5. | Tracking Adjustment | 9-12 |
| 9-5-1. | Tracking Check | 9-12 |
| 9-5-2. | Tracking Adjustment | 9-13 |
| 9-6. | Stationary Head Height Adjustment | 9-16 |
| 9-7. | CTL Head Position Adjustment | 9-17 |
| 9-8. | PG Phase Adjustment | 9-18 |
| 9-9. | CTL Head Position Check | 9-19 |
| 9-10. | PRE-PG Phase Adjustment | 9-20 |
| 9-11. | CONFI/ADVANCE Head Height Adjustment | 9-22 |
| 9-12. | REC Head Height Adjustment | 9-24 |
| 9-13. | Self Record/Playback RF Waveform Check | 9-26 |

10. SERVO SYSTEM ALIGNMENT

| | | |
|-------|--|-------|
| 10-1. | Servo System Alignment Sequence | 10-2 |
| 10-2. | Analog Reference Voltage Adjustment | 10-2 |
| 10-3. | DAC Adjustment | 10-3 |
| 10-4. | Drum Motor Adjustment | 10-4 |
| 10-5. | Capstan Motor Adjustment | 10-6 |
| 10-6. | S-Reel Motor Adjustment | 10-8 |
| 10-7. | T-Reel Motor Adjustment | 10-9 |
| 10-8. | Tape Beginning/End Sensor Adjustment | 10-11 |

11. ANALOG SIGNAL SYSTEM ALIGNMENT

| | | |
|--------|--|------|
| 11-1. | Analog Signal System Alignment Procedure | 11-2 |
| 11-2. | Common Mode Noise Cancellation Adjustment | 11-3 |
| 11-3. | REC Preset Level Adjustment | 11-3 |
| 11-4. | D-MIX Level Adjustment | 11-3 |
| 11-5. | Line Amplifier Output Level Adjustment | 11-4 |
| 11-6. | Level Meter Calibration | 11-4 |
| 11-7. | PB Level Adjustment | 11-4 |
| 11-8. | PB Frequency Response Adjustment | 11-4 |
| 11-9. | PB TC and CTL Level Adjustment | 11-5 |
| 11-10. | Erase Current Adjustment | 11-5 |
| 11-11. | Bias Current Adjustment | 11-6 |
| 11-12. | REC Level Adjustment | 11-6 |
| 11-13. | REC Amp Frequency Response Adjustment | 11-7 |
| 11-14. | REC TC and CTL Level Adjustment | 11-7 |
| 11-15. | TC Insert Crosstalk Adjustment | 11-8 |
| 11-16. | PB TC, CTL Comparator Level Adjustment | 11-8 |

12. RF SIGNAL SYSTEM ALIGNMENT

| | | |
|---------|--|-------|
| 12-1. | Alignment Sequence | 12-2 |
| 12-2. | Advance Window Adjustment | 12-2 |
| 12-3. | PB Equalizer Adjustment | 12-3 |
| 12-4. | Setting RF-15 Control Data | 12-4 |
| 12-4-1. | RF-15 Control Data Change Procedure | 12-5 |
| 12-4-2. | Menu Selection | 12-6 |
| 12-4-3. | PB Equalizer Adjustment | 12-7 |
| 12-4-4. | Record Drive Adjustment | 12-10 |
| 12-4-5. | RF Control Data Write | 12-13 |
| 12-5. | RF Envelope Level Adjustment | 12-13 |

13. FUNCTION CONTROL PANEL ALIGNMENT

| | | |
|-------|--|------|
| 13-1. | Function Control Panel Alignment Sequence | 13-2 |
| 13-2. | Control Panel Power Supply Adjustment | 13-2 |
| 13-3. | Jog Dial Pulse Amplifier Adjustment | 13-3 |

APPENDIX

Volume 2

- A. BLOCK DIAGRAM**
- B. SCHEMATIC DIAGRAMS & BOARD LAYOUT**
- C. SEMICONDUCTOR PIN ASSIGNMENTS**
- D. REPLACEABLE PARTS & OPTIONAL FIXTURE**

SECTION 1 INSTALLATION

1-1. UNPACKING AND REPACKING

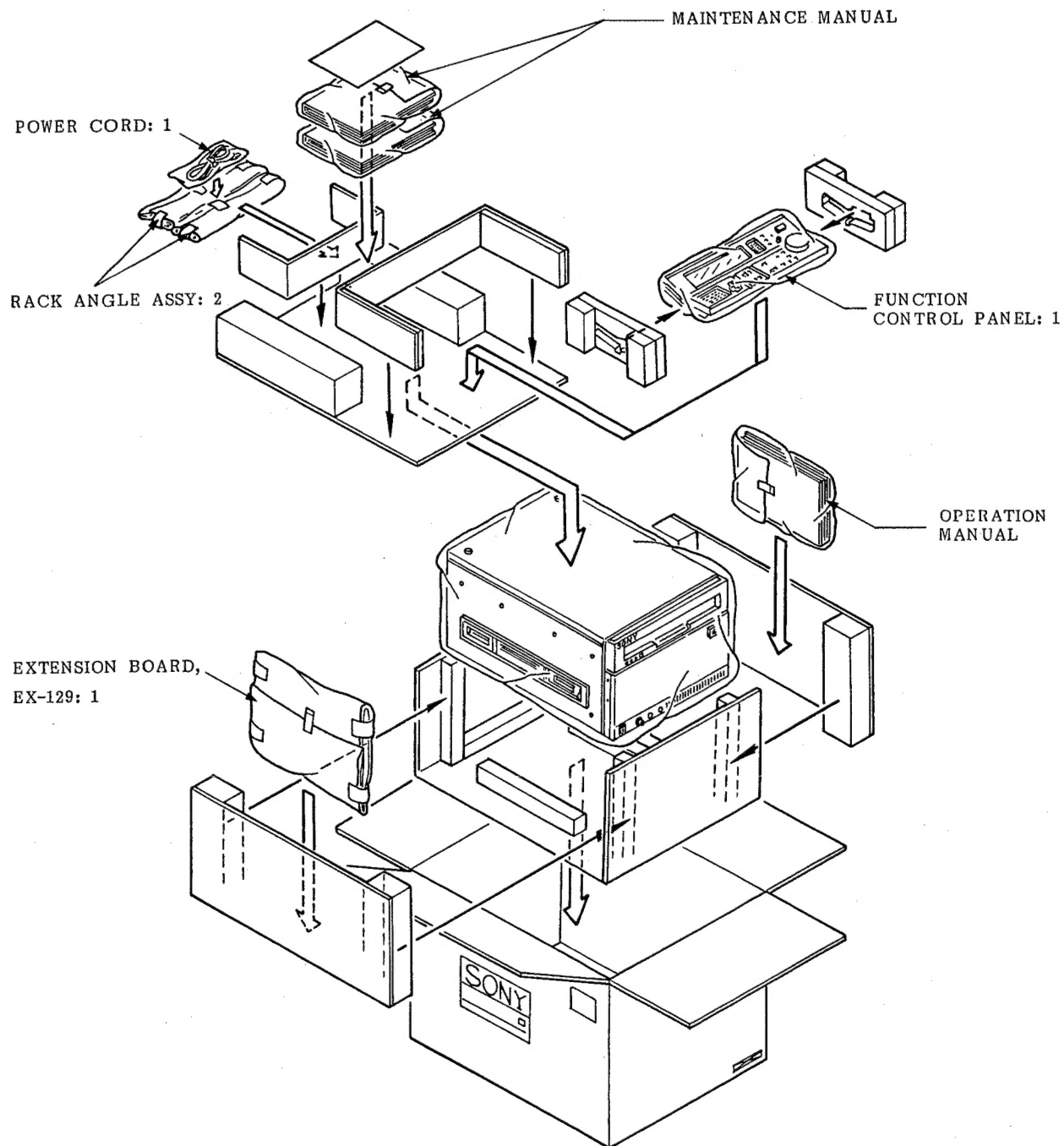



1-2. ACCESSORIES SUPPLIED

Function Control Panel: 1

Rack Angle Assy: 2

Used for mounting the DVR-1000 on the rack.

Power Cord: 1

Operation manual

English version is provided with the USA/Canadian model. English version, French version and German version are provided with the European model.

Maintenance manual

Vol-1 and Vol-2 are provided with the unit.

Extension board: EX-129: 1

Used for checking or repairing the circuit board in the card rack.

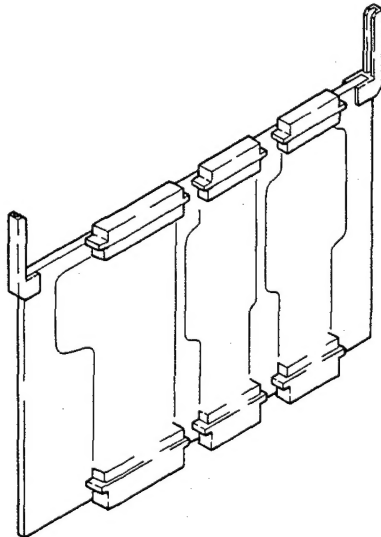

1-3. POWER REQUIREMENT

1-3-1. Capacity of AC Power Source

Power Line Voltage 90 to 132 V or 198 to 264 V
Power Line Frequency 50/60 Hz
Power Consumption 350 W max

Note: When the unit is first switched ON, a maximum surge current of 35 A will flow.

The AC supply must therefore be capable of supplying this surge current otherwise the power supply breaker on the supply side of the AC power supply may trip, or the unit may fail to function normally.

1-3-2. Power Cord

Approx. 2.4 m in length (For J,UC)

Approx. 2.5 m in length (For EK)

For J

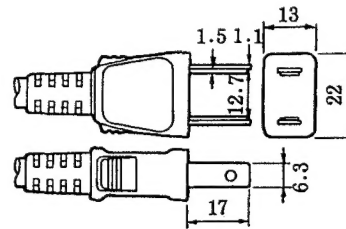

For UC

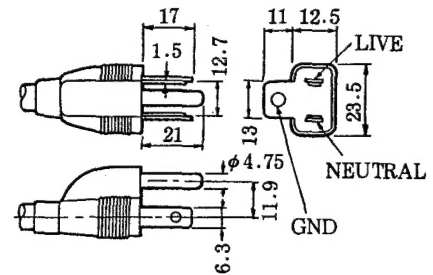

For EK



UNIT: mm

Note: Obtain an AC plug and install it on the end of the cable.

1-3-3. Setting Voltage Selector

If it is necessary to change the AC voltage setting, remove the cover of the voltage selector at the rear of the power supply unit, then after changing the voltage setting install the cover so that it is facing towards the selected voltage indication.

<REAR VIEW>

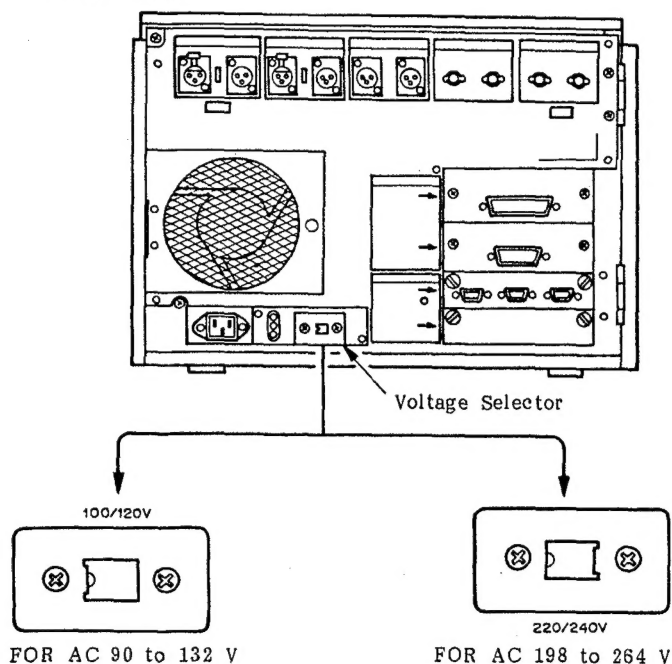

1-4. INSTALLATION CONDITIONS

Operating Temperature +5 C to +40 C
 Storage Temperature -20 C to +60 C
 Humidity 20% to 80% (noncondensing)

Install the DVR-1000 on a flat stable base, or in the specified position on the DVPC-1000.

The weight of the DVR-1000 after the blank panel has been removed from it and the function control panel installed on it is about 48 Kg.

The total weight when the DVR-1000 is installed on the DVPC-1000 is about 150 Kg.

Note: When installing the DVR-1000 on the DVPC-1000, ensure that the feet on the underside of the DVR-1000 are correctly seated in the foot base at the top of the DVPC-1000.

Do not install the unit in the following locations:

- Exposed to direct sunlight or powerful lighting
- In a dusty location
- In a location which is subjected to vibration
- In a powerful electric or magnetic field
- In a location which is generated to electric noise
- In a location which is generated to static electricity noise

1-3-4. Ventilation/Heat Sink

The two fans are for cooling the DVR-1000. If either the intake or exhaust should become clogged or the fans stop, damage may result to the power unit etc.

The heat sinks provided on each board are rated on the assumption that cooling will be provided by the fans. Consequently, the unit should not be operated too long without fan cooling (such as when the unit is opened for checks etc.)

To protect the internal parts from dust, an air filter is mounted to the connector panel. Clean the filter periodically referring to 5-2-1 "Cleaning method."



1-5. INSTALLATION SPACE

(1) External Dimensions

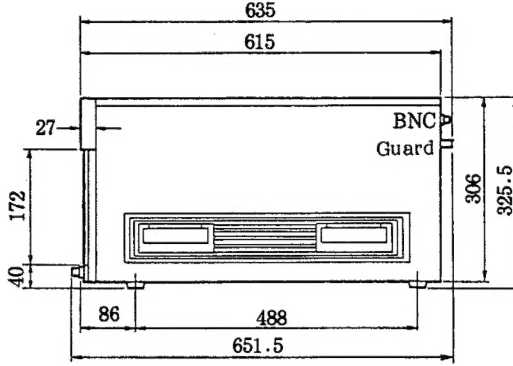
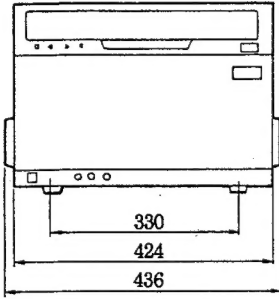

When installing the FUNCTION CONTROL PANEL

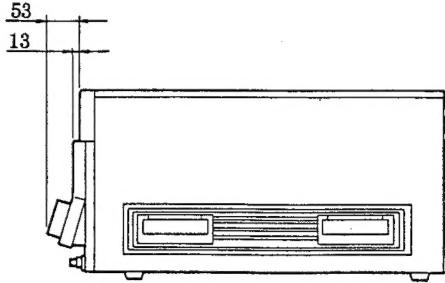

External Dimensions: FUNCTION CONTROL PANEL

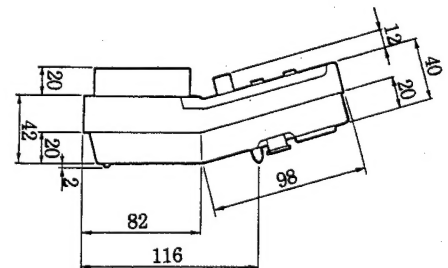
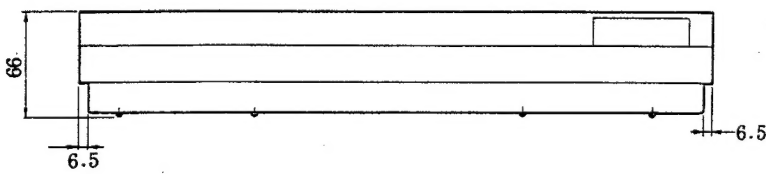
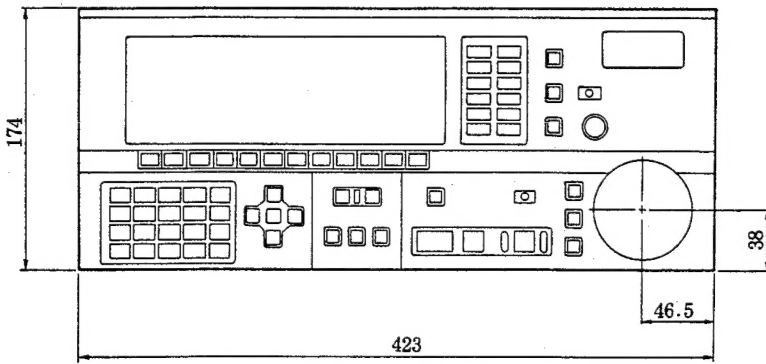

UNIT: mm

(2) External Dimensions: When installing DVR-1000 on the DVPC-1000.

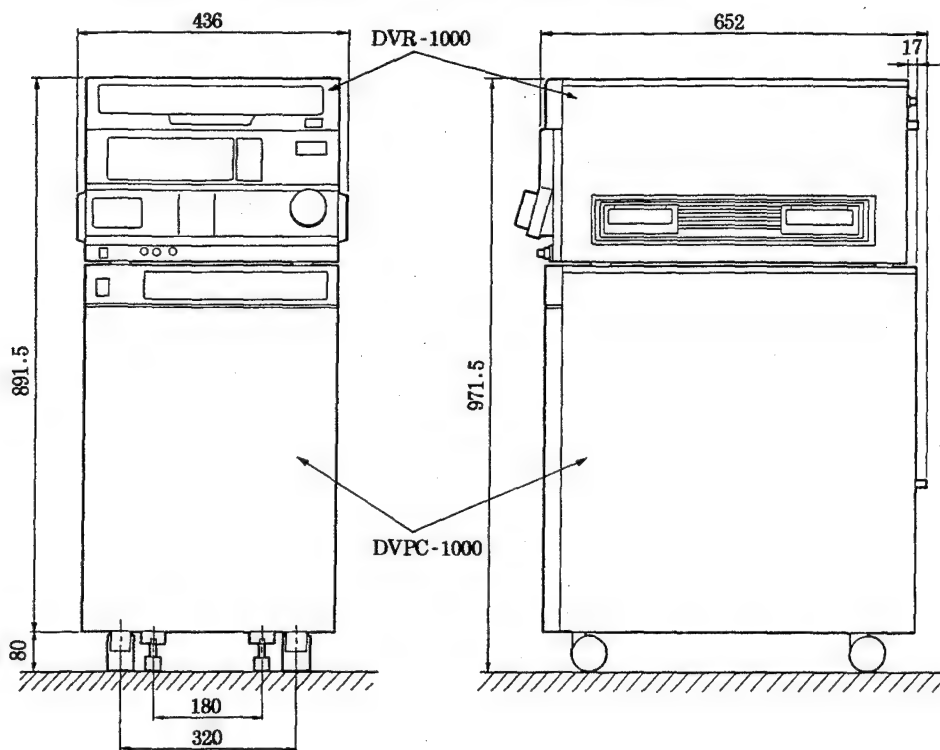

(3) Working Space: When opening Connector Panel.

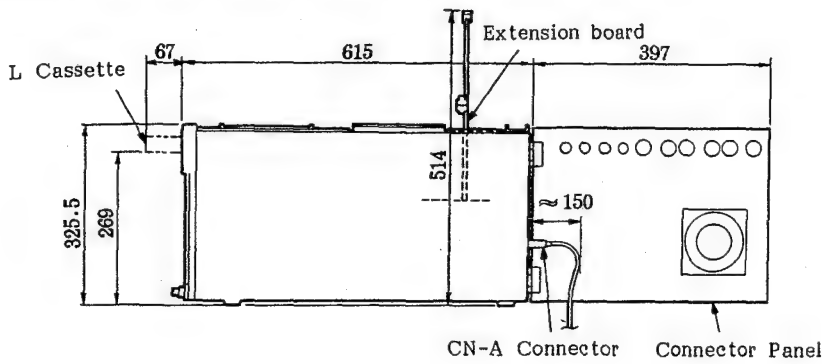

(4) Working Space: When rack-mounting

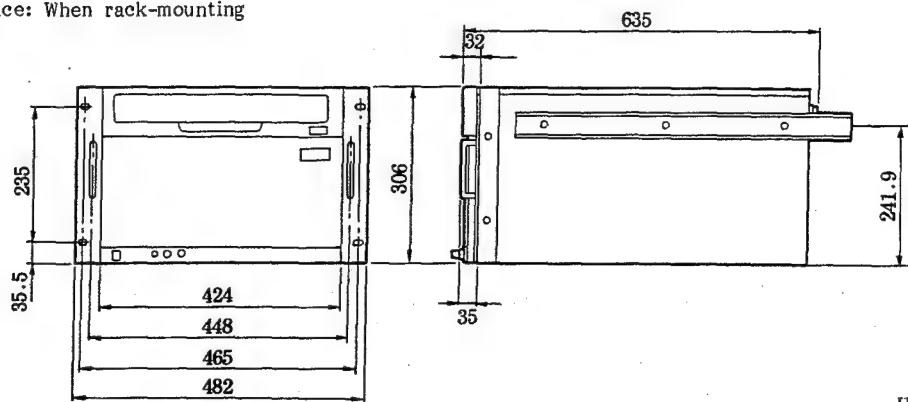

UNIT: mm

1-6. INSTALLING THE FUNCTION CONTROL PANEL

When installing the control panel and the main unit at a distance, the flat cable (connection cable) can be extended by 10 m using the following cable instead.
CORD, CONNECTION (10M)
 SONY Part No: 1-559-936-11

The blank panel removal

Remove the left and right screws (B3 x 8, two each), and remove the blank panel.

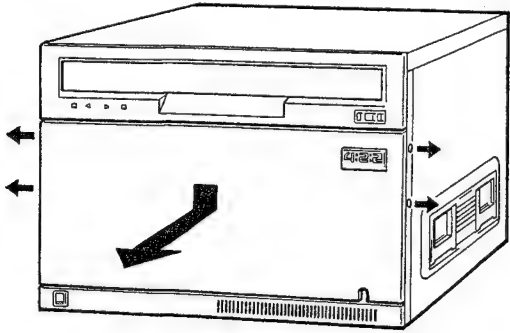

Installing the function control panel

- (1) When installing the function panel on the VTR
 ① Remove the six screws (PWH 3 x 6) from the rear of the blank panel, then remove the Bracket.

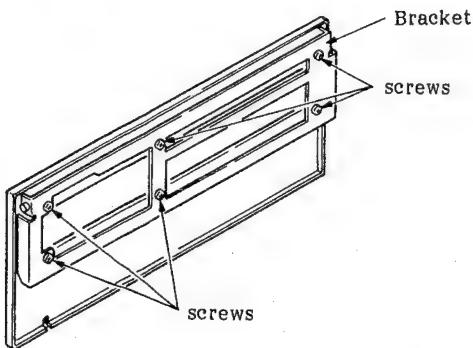

- ② Using the screws that were removed in ①, install the bracket on the function control panel.

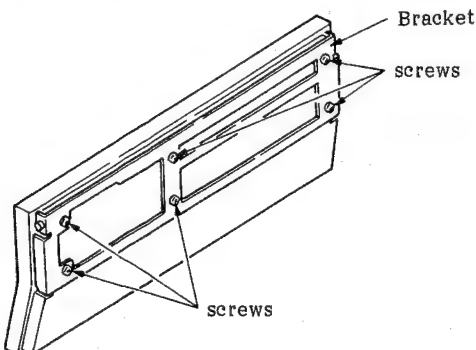

- ③ Remove the end of the Function control panel from the cable clamber, unravel two turns, then once again fit a suitable part of the cable into the cable clamber to prevent the remaining cable from unraveling.

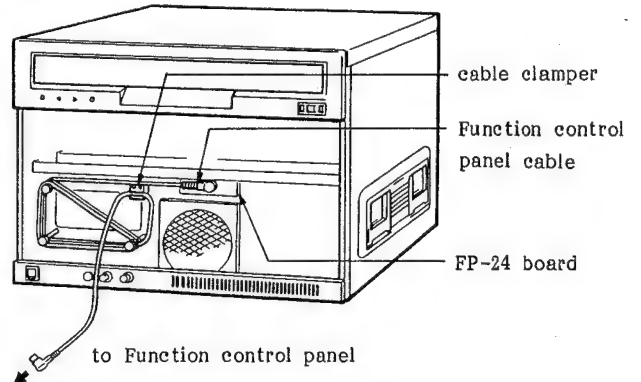

- ④ Insert the connector of the Function control panel cable in the function control panel, then fix it in place using the screws (B3 x 8, four) that were used to clamp the blank panel, as shown in the figure below.

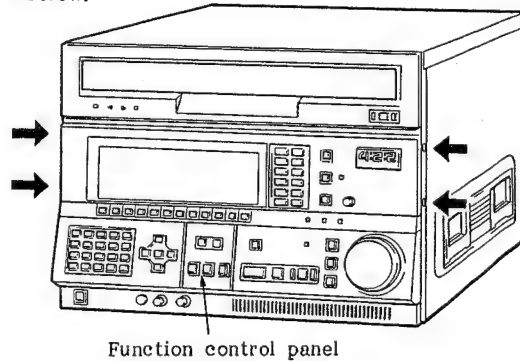

Note: Mount the control panel so that the escutcheon harness is inserted between the side plate of the main body and the side plate of the cassette controller. Otherwise, the harness might be caught between the front plate of the cassette controller and the control panel.

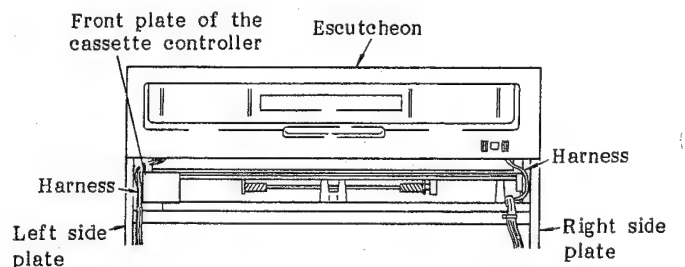

(2) When using the unit remotely

- ① Remove the end of the Function control panel cable from the cable clamber, unravel the entire cable, then reclamp it as shown in the figure.

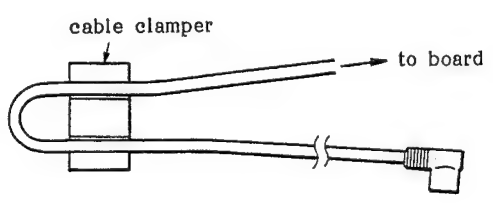

- ② Pass the cable through the notch in the clamp panel, then fix the panel using the panel screws (B3 x 8, four).

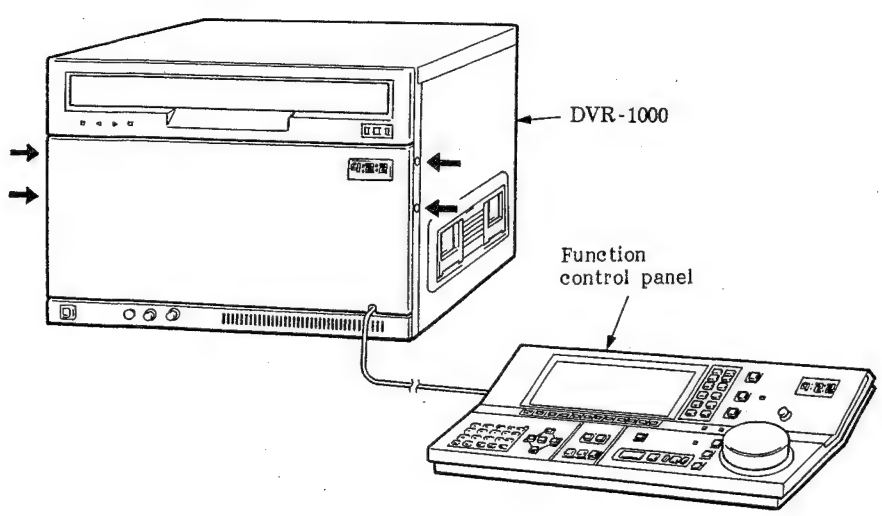
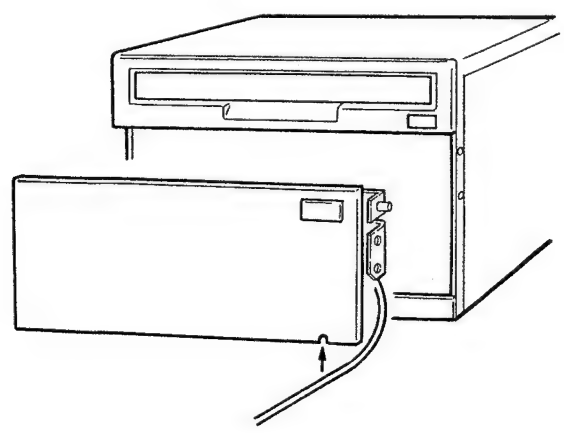

1-7. RACK-MOUNTING

This section describes a method for mounting the DVR-1000 on a 19-inch standard rack or a system console.

Prepare the following parts.

- Slide Rail : 1 set (2)
- SONY Part No. 3-735-121-01
- Bracket : 4
- SONY Part No. 3-735-120-01
- Plate Nut : 4
- SONY Part No. 2-379-736-02
- Screw +B4 x 12 : 8
- SONY Part No. 7-682-563-04
- Screw +K5 x 12 : 8
- SONY Part No. 7-682-276-09
- Washer $\phi 4$: 8
- SONY Part No. 7-688-004-11
- Washer $\phi 5$: 8
- SONY Part No. 7-688-005-01
- Nut N5 : 8
- SONY Part No. 7-684-025-04

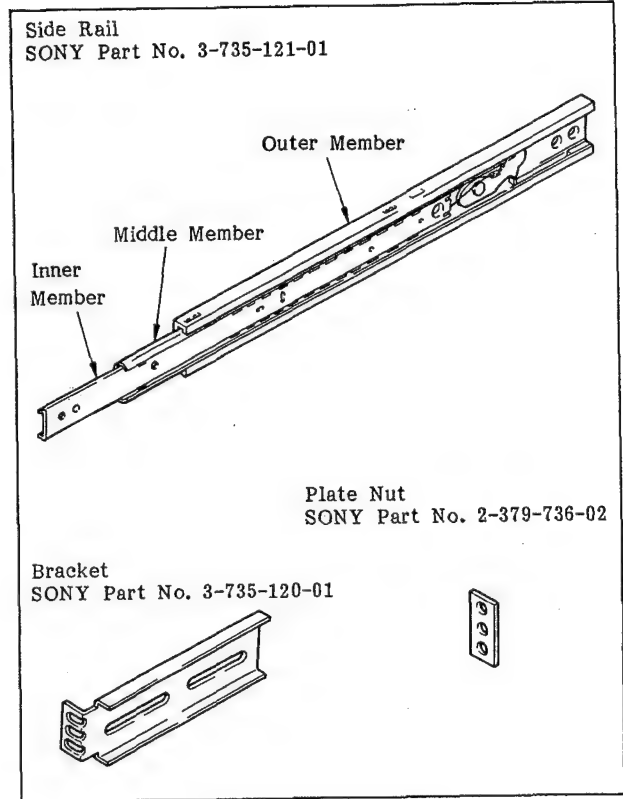

Parts for Rack Mounting

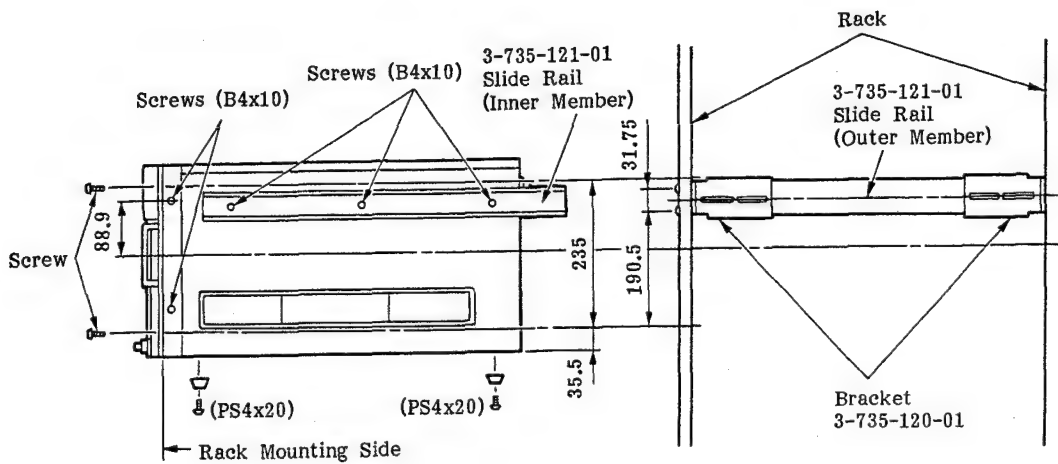

Unit: mm

Mounting Procedure

- ① Pull out the inner member from the slide rail. Then remove the inner member by pushing the stopper shown in the figure below.

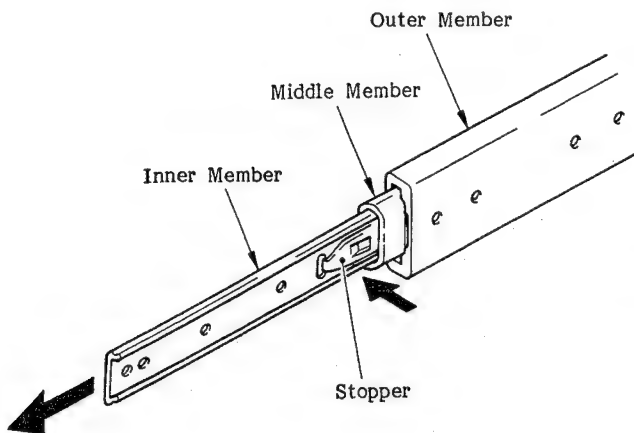

- Use the set screws holding the side plate of the VTR for mounting the rack angle assembly and the inner member.

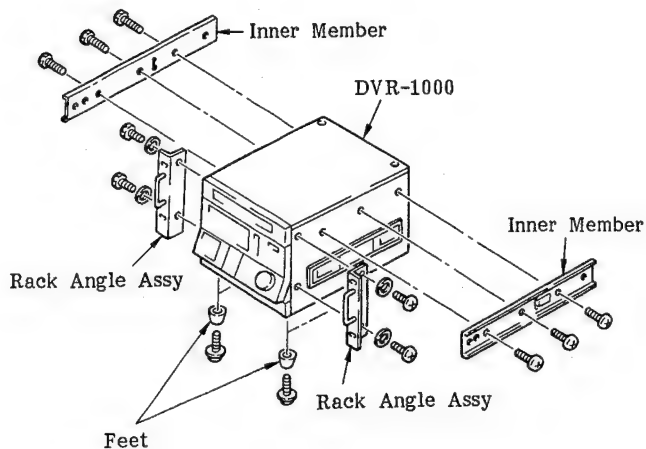

- ② Mount the rack angle assembly (attached to the VTR) and the inner member on the VTR. Remove the Feet from The VTR, if necessary.

- ③ Mount the bracket on the outer member and temporarily tighten it with screws. Slide the middle member in the direction of the arrow so that you can see the screw holes of the outer member.

Position where the inner member is to be attached

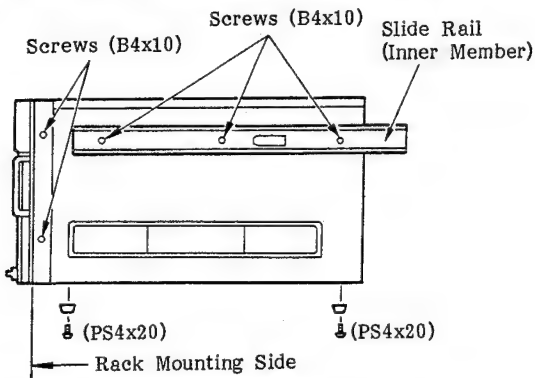

Hole Positions for the set screws to hold the slide rail

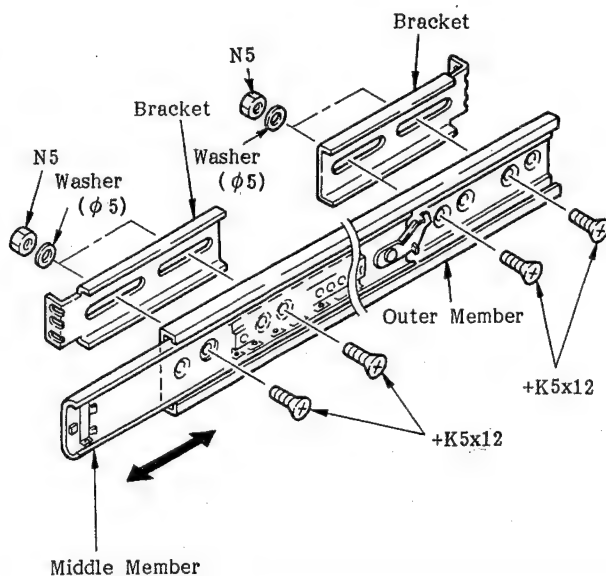
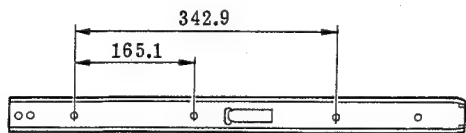

- ④ Mount the outer member assembly on the rack and temporarily tighten it with screws. The depth of the outer member may differ according to rack. In such a case, slide the racket that was temporarily tightened with screws in step ③ in the direction of the arrow to adjust the rack mounting position. (Be sure to hold the bracket and the outer member a two points.)

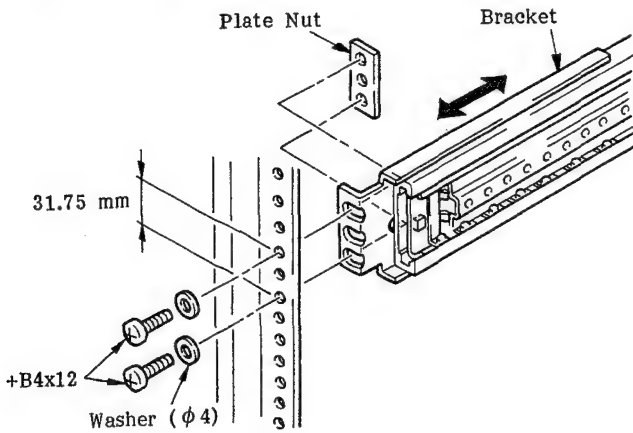

- ⑤ Adjust the distance A between the outer member and the rack angle mounting side shown in the figure below so that it meets the specification.

Spec.: $A=50\pm 3\text{mm}$

After the adjustment is made, securely tighten the set screws that were temporarily tightened in step ③.

③.

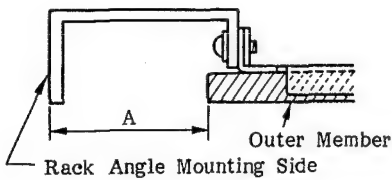

Rack Angle Mounting Side
Outer Member

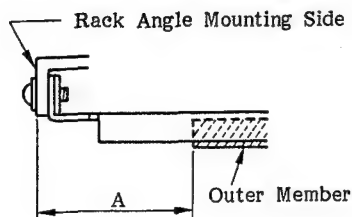

Rack Angle Mounting Side
Outer Member

- ⑥ Release the stopper of the inner member to install the DVR-1000. Verify that the DVR-1000 can be installed smoothly, and then securely tighten the screws (+B4x12) that were temporarily tightened in step ④.

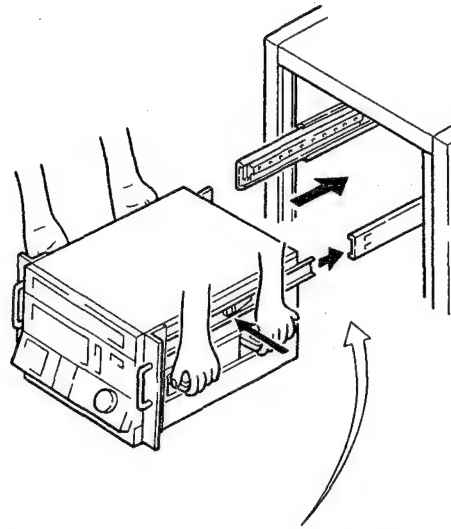

- Move the slide bearing for installation, as shown in the figure below.

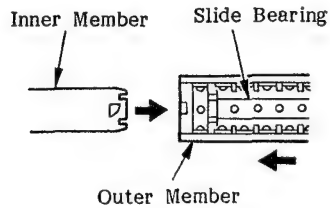

1-8. INPUT/OUTPUT INTERFACE

1-8-1. Matching Connectors and Cables

| DVR-1000 Connectors | | Matching Connectors/Cables | |
|---------------------|---------------------|---|----------------------------|
| Used for | Type | Type | Sony Part No. |
| CUE IN | XLR,3-pin,Female | XLR,3-pin,Male | 1-508-084-00(Note 1) |
| CUE OUT | XLR,3-pin,Male | XLR,3-pin,Female | 1-508-083-00(Note 2) |
| TIME CODE IN | XLR,3-pin,Female | XLR,3-pin,Male | 1-508-084-00(Note 1) |
| TIME CODE OUT | XLR,3-pin,Male | XLR,3-pin,Female | 1-508-083-00(Note 2) |
| SPARE 1 | BNC | BNC | |
| SPARE 2 | BNC | BNC | |
| MONITOR OUT R | XLR,3-pin,Male | XLR,3-pin,Female | 1-508-083-00(Note 2) |
| MONITOR OUT L | XLR,3-pin,Male | XLR,3-pin,Female | 1-508-083-00(Note 2) |
| WFM OUT MONITOR | BNC | BNC | |
| WFM OUT TRIGGER | BNC | BNC | |
| CN-A | D-Sub,50-pin,Female | CN-A Cable ASSY | 1-559-042-11(Note 3) |
| CN-B | IEEE-488 Connector | CN-B Cable ASSY | 1-556-535-31(Note 4) |
| RS422 IN | D-Sub,9-pin,Female | D-Sub,9-pin,Female RCC-5G Cable ASSY RCC-10G Cable ASSY RCC-30G Cable ASSY | 1-509-140-00 |
| RS422 OUT | D-Sub,9-pin,Female | | Optional Accessory(Note 5) |
| RS422 IN/OUT | D-Sub,9-pin,Female | | Optional Accessory(Note 5) |
| HEAD PHONES | 6 ϕ Phone Jack | 6 ϕ phone Plug | Optional Accessory(Note 5) |

(Note 1) Equivalent to CANNON XLR-3-12C.

(Note 2) Equivalent to CANNON XLR-3-11C.

(Note 3) Used for connecting the DVR-1000 with DVPC-1000. The length of the cable is 1 m.
One connector is supplied to DVPC-1000.

(Note 4) Used for connecting the DVR-1000 with DVPC-1000. The length of the cable is 1 m.
One connector is supplied to DVPC-1000.

(Note 5) The length of the cable are 5 m, 10 m and 30 m.

1-8-2. Input/Output Signal of the Connectors

① INPUT

CUE IN; 4 dBm (J)/8 dBm (UC, EK)

600/10k ohms, balanced

TIME CODE IN; 1.2 Vrms

600/10k ohms, balanced

② OUTPUT

CUE OUT; 4 dBm (J)/8 dBm (UC, EK)

600 ohms, balanced

TIME CODE OUT; 1.2 Vrms

600 ohms, balanced

MONITOR OUT R/L; 4 dBm (J)/8 dBm (UC, EK)

600 ohms, balanced, variable level control

HEAD PHONES; 8 ohms, unbalanced, variable level control



③ CN-A Connector

| Pin No. | Signal | Spec | Description |
|---------|-------------|--------------------------|--|
| 1 | PB A (X) | ECL | A-ch PB RF Signal |
| 18 | PB A (G) | ECL | |
| 34 | PB A (Y) | ECL | B-ch PB RF Signal |
| 2 | PB B (X) | ECL | |
| 19 | PB B (G) | ECL | C-ch PB RF Signal |
| 35 | PB B (Y) | ECL | |
| 3 | PB C (X) | ECL | D-ch PB RF Signal |
| 20 | PB C (G) | ECL | |
| 36 | PB C (Y) | ECL | A-ch REC RF Signal |
| 4 | PB D (X) | ECL | |
| 21 | PB D (G) | ECL | B-ch REC RF Signal |
| 37 | PB D (Y) | ECL | |
| 23 | REC A (Y) | ECL | C-ch REC RF Signal |
| 39 | REC A (X) | ECL | |
| 24 | REC B (Y) | ECL | D-ch REC RF Signal |
| 40 | REC B (X) | ECL | |
| 25 | REC C (Y) | ECL | REC Clock |
| 41 | REC C (X) | ECL | |
| 26 | REC D (Y) | ECL | Reference Frame Pulse |
| 42 | REC D (X) | ECL | |
| 27 | REC CK (Y) | ECL | Reference Audio Frame Pulse |
| 43 | REC CK (X) | ECL | |
| 5 | FRP (+) | TTL | Reference CF Pulse |
| 6 | FRP (-) | TTL | |
| 7 | AFP (+) | TTL | Reference Drum PG Pulse |
| 8 | AFP (-) | TTL | |
| 9 | CFP (+) | TTL | 525/625 Select Signal |
| 10 | CFP (-) | TTL | |
| 11 | DRP (+) | TTL | PB Audio Frame Pulse |
| 12 | DRP (-) | TTL | |
| 13 | LSTD (+) | TTL("H"=525, "L"=625) | PB CF Pulse |
| 14 | LSTD (-) | TTL | |
| 28 | AFT (-) | TTL | Digital Audio Monitor Signal |
| 44 | AFT (+) | TTL | |
| 29 | CFT (-) | TTL | Digital Audio Monitor Signal (L) (The input Signal is selected by the function control panel.) |
| 45 | CFT (+) | TTL | |
| 15 | AMIX (X) | -20dBs | Digital Audio Monitor Signal (R) (The input Signal is selected by the function control panel.) |
| 31 | AMIX (G) | | |
| 48 | AMIX (Y) | -20dBs | |
| 16 | AMONI L (X) | | |
| 32 | AMONI L (G) | -20dBs | |
| 49 | AMONI L (Y) | | |
| 17 | AMONI R (X) | -20dBs | |
| 33 | AMONI R (G) | | |
| 50 | AMONI R (Y) | | |
| 22 | SPARE A (-) | | |
| 38 | SPARE A (+) | | |
| 30 | SPARE B (-) | | |
| 46 | SPARE B (+) | | |
| 47 | CASSIS GND | Frame GND | |

④ CN-B Connector (GP-IB)

| Pin No. | Signal | Spec | Description |
|---------|------------|-----------|---------------------------|
| 1 | IFDI01 | TTL | } 8 Bit Parallel Data Bus |
| 2 | IFDI02 | TTL | |
| 3 | IFDI03 | TTL | |
| 4 | IFDI04 | TTL | |
| 13 | IFDI05 | TTL | |
| 14 | IFDI06 | TTL | |
| 15 | IFDI07 | TTL | |
| 16 | IFDI08 | TTL | |
| 6 | IFDAV | TTL | } Handshake Bus |
| 7 | IFNRFD | TTL | |
| 8 | IFNDAC | TTL | |
| 9 | IFIFC | TTL | } Management Bus |
| 10 | IFSRQ | TTL | |
| 11 | IFATN | TTL | |
| 17 | IFREN | TTL | |
| 5 | IFE01 | TTL | |
| 12 | SHIELD | Frame GND | |
| 18 | IFDAV (G) | GND | |
| 19 | IFNRFD (G) | GND | |
| 20 | IFNDAC (G) | GND | |
| 21 | IFIFC (G) | GND | |
| 22 | IFSRQ (G) | GND | |
| 23 | IFATN (G) | GND | |
| 24 | LOGIC GND | GND | |

⑤ RS-422 IN, RS-422 OUT, RS-422 IN/OUT Connectors

| Pin No. | Signal | Spec | Description |
|---------|--------------|------|------------------------|
| 2 | REM-A IN (-) | TTL | } Serial Remote Input |
| 7 | REM-A IN (+) | TTL | |
| 8 | REM-A OUT(-) | TTL | } Serial Remote Output |
| 3 | REM-A OUT(+) | TTL | |
| 4 | GND | GND | |
| 6 | GND | GND | |
| 1 | NC | | |
| 5 | NC | | |
| 9 | NC | | |



1-9. INITIAL SETTING OF SWITCHES AND JUMPERS

1-9-1. Changing the Line Output Impedances

LO-05 Board

A, B, C, D, E, F, G, H, I (soldered jumpers):

Line output impedances

These jumpers select line output impedance of the TIME CODE, CUE and MONITOR OUT R/L connectors. These output impedances are set to 600 ohms when the unit is shipped. However they can be changed through the remodeling shown below to 37.5 ohms or 150 ohms.

LO-05 BOARD

—Solder Side—

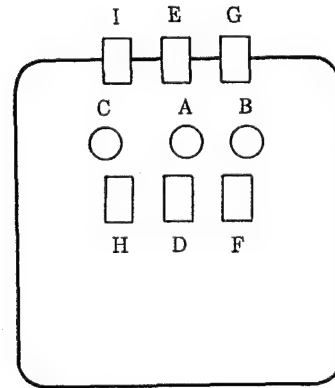
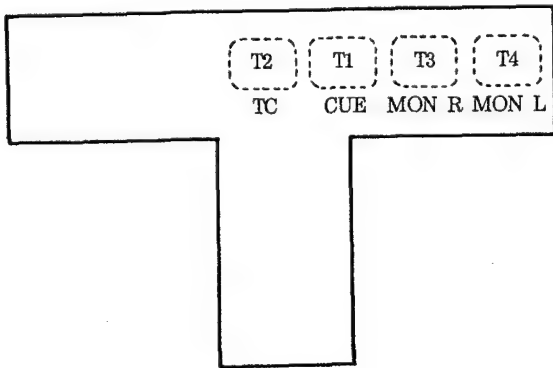

| OUTPUT IMPEDANCE | TRACE (each channel) | | | | | | | | |
|------------------|----------------------|---|---|---|---|---|---|---|---|
| | A | B | C | D | E | F | G | H | I |
| 600 Ω | | | | | | | | | |
| 150 Ω | | | | | | | | | |
| 37.5 Ω | | | | | | | | | |

- ; Keep unchanged as shorted.
- ; Keep unchanged as open.
- ; Short (solder).
- ; Open (cut trace).

1-9-2. Changing the Line Input Impedances

TR-40 Board

A, B, C, D, E, F (soldered jumpers):

Line input impedances

These jumpers select the line input impedance of the TIME CODE and CUE connectors. These input impedances are set to 600 ohms when the unit is shipped. However they can be changed through the remodeling shown below to 37.5 ohms, 150 ohms or 10k ohms.

TR-40 BOARD

—Solder Side—

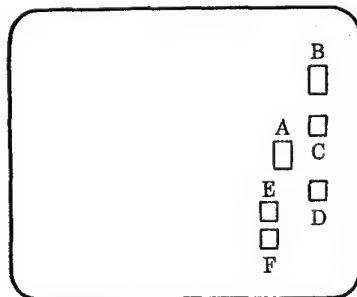

| INPUT IMPEDANCE | CUE | | TIME CODE | | REAR PANEL SW |
|-----------------|---|---|---|---|----------------|
| | A | E-F | B | C-D | 600 Ω / 10 k Ω |
| 10 k Ω | <input type="checkbox"/> <input type="checkbox"/> | <input type="checkbox"/> <input type="checkbox"/> | <input type="checkbox"/> <input type="checkbox"/> | <input type="checkbox"/> <input type="checkbox"/> | 10 k Ω |
| 600 Ω | <input type="checkbox"/> <input type="checkbox"/> | <input type="checkbox"/> <input type="checkbox"/> | <input type="checkbox"/> <input type="checkbox"/> | <input type="checkbox"/> <input type="checkbox"/> | 600 Ω |
| 150 Ω | <input checked="" type="checkbox"/> <input checked="" type="checkbox"/> | <input type="checkbox"/> <input type="checkbox"/> | <input checked="" type="checkbox"/> <input checked="" type="checkbox"/> | <input type="checkbox"/> <input type="checkbox"/> | 600 Ω |
| 37.5 Ω | <input checked="" type="checkbox"/> <input checked="" type="checkbox"/> | <input checked="" type="checkbox"/> <input checked="" type="checkbox"/> | <input checked="" type="checkbox"/> <input checked="" type="checkbox"/> | <input checked="" type="checkbox"/> <input checked="" type="checkbox"/> | 600 Ω |

; Keep unchanged as open.

; Short (solder).

; Solder 50 ohms resistance between E-F or B-C.

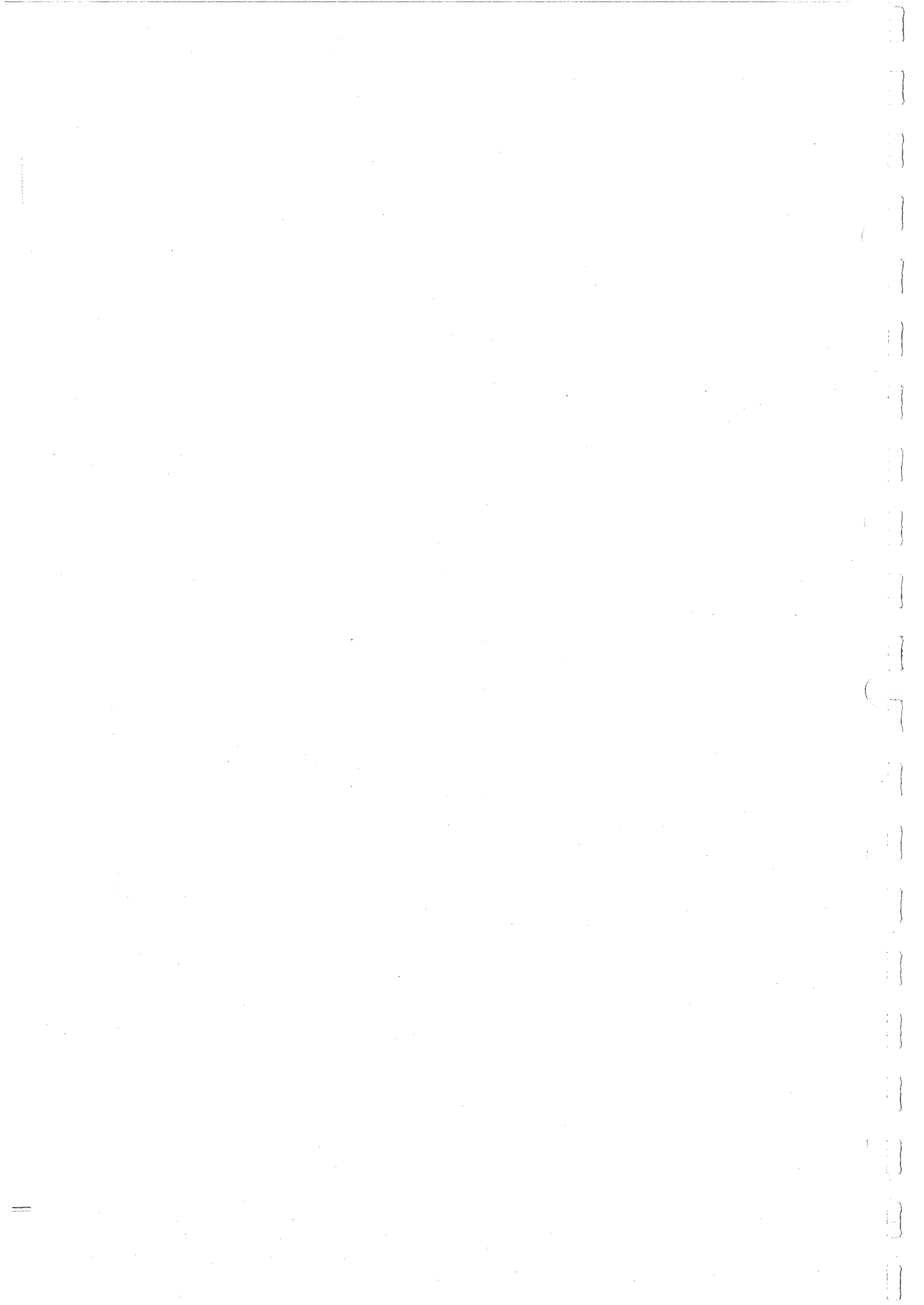

SECTION 2 SERVICE INFORMATION

2-1. PRINCIPAL COMPONENT LOCATION

FUNCTION CONTROL PANEL

- 1 CP-106 Board: Function Control Panel
- 2 SW-157 Board: Switch
- 3 SW-158 Board: Switch
- 4 PS-139 Board: Power Supply Relaying
- 5 DET-3 Board: Search Dial Detector
- 6 RE-44 Board: Rotary Encoder Detector
- 7 Rotary Encoder
- 8 El Panel

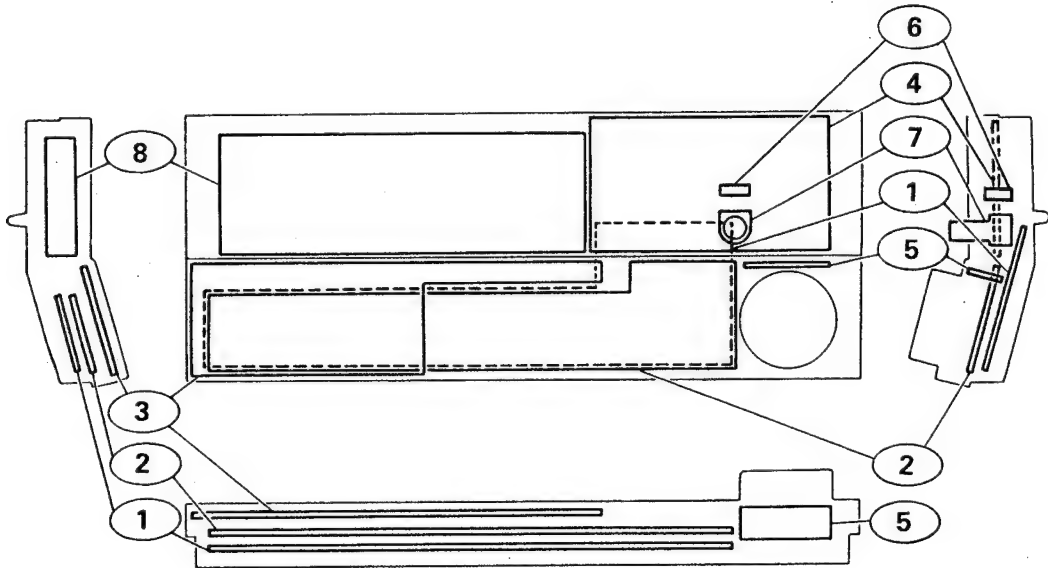

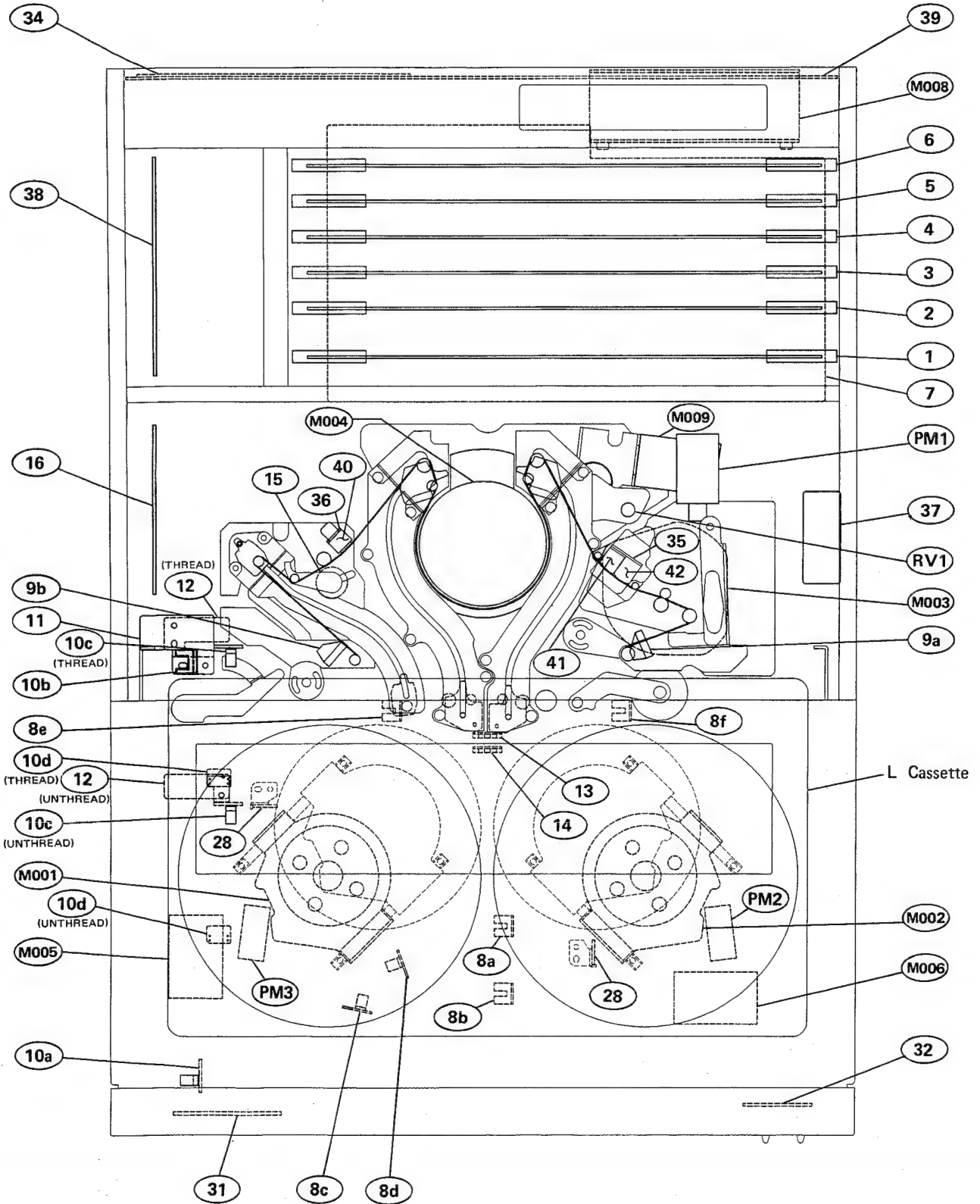

PRINTED CIRCUIT BOARD

CARD RACK

| | | |
|---|---------------|------------------------|
| 1 | RF-15 Board: | RF |
| 2 | AE-05 Board: | Audio(CUE/CTL) & Erase |
| 3 | CD-35 Board: | Capstan & Drum Servo |
| 4 | RS-23 Board: | Reel Servo |
| 5 | SP-01 Board: | Servo Processor |
| 6 | SY-69 Board: | System Controller |
| 7 | MB-133 Board: | Mother Board |

SENSOR & CASSETTE CONTROLLER

| | | |
|-----|--------------|---|
| 8a | PC-34 Board: | Sensor,User Center (M) |
| 8b | PC-34 Board: | Sensor,User Center (L) |
| 8c | PC-34 Board: | Sensor,Reel Positon (M) |
| 8d | PC-34 Board: | Sensor,Reel Positon (L) |
| 8e | PC-34 Board: | Sensor,User S |
| 8f | PC-34 Board: | Sensor,User T |
| 9a | PC-36 Board: | Tape End Sensor |
| 9b | PC-36 Board: | Tape Beginning Sensor |
| 10a | PC-37 Board: | Cassette Compartment Up Sensor (FIX) |
| 10b | PC-37 Board: | Cassette Compartment Down Sensor (FIX) |
| 10c | PC-37 Board: | Cassette-down Sensor (MOVE) |
| 10d | PC-37 Board: | Cassette-in Sensor (MOVE) |
| 11 | CS-21 Board: | Cassette Controller (FIX) |
| 12 | CC-29 Board: | Cassette Controller (MOVE) |
| 13 | LE-52 Board: | Coding Hole Sensor (LED) |
| 14 | TR-41 Board: | Coding Hole Sensor (PTR) |
| 15 | DE-17 Board: | Tension Sensor |
| 16 | SE-47 Board: | Sensor Relaying |

INTERFACE

| | | |
|----|---------------|------------------------------|
| 17 | PR-87 Board: | Processor Interface (CN-A) |
| 18 | IF-135 Board: | GP-IB Interface Board (CN-B) |
| 19 | IF-134 Board: | RS-422 Interface Board |
| 20 | IF-138 Board: | Interface Mother Board |

POWER SUPPLY & MOTOR DRIVER

| | | |
|----|---------------|---------------------------|
| 21 | PS-138 Board: | Power Supply |
| 22 | RE-32 Board: | Switching Regulator |
| 23 | CT-74 Board: | Regulator Controller |
| 24 | FC-37 Board: | Power Supply Relaying |
| 25 | MD-43 Board: | Motor Driver |
| 26 | MB-137 Board: | Motor Drive Mother Board |
| 27 | PD-36 Board: | Power Rotary Trans Driver |
| 28 | CN-157 Board: | Reel Motor Relaying |

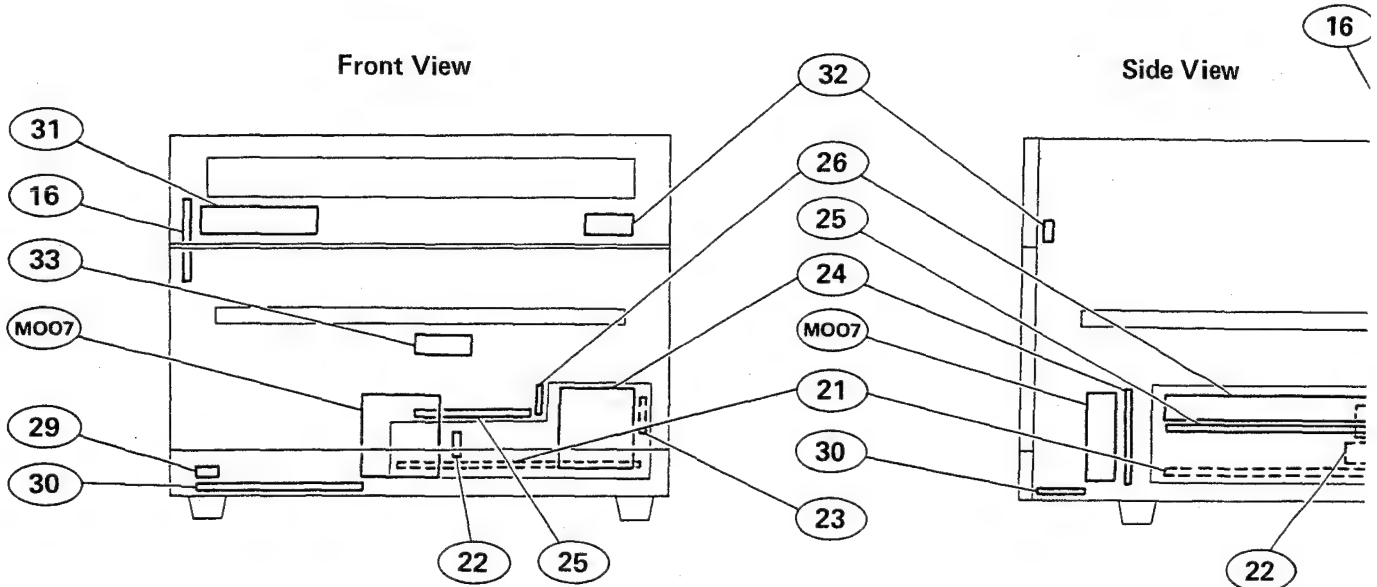

OTHERS

- 29 PE-18 Board: Power Indicator
- 30 VR-50 Board: Volume
- 31 LE-56 Board: Indicator (LOAD & RUN)
- 32 SW-179 Board: Eject Switch
- 33 FP-24 Board: Control Panel Relaying

- 34 CN-191 Board: BNC Panel
- 35 AH-13 Board: R/P Head
- 36 AH-15 Board: Full Erase Head
- 37 BP-10 Board: Relaying
- 38 TR-40 Board: Input Transfrmer
- 39 LO-05 Board: Audio Line Out

MOTOR, SOLENOID, HEAD, etc.

- 40 Full Erase Head
- 41 CUE/CTL/TC ERASE HEAD
- 42 CUE/CTL/TC R/P HEAD

- M001 Motor, S-Reel
- M002 Motor, T-Reel
- M003 Motor, Capstan
- M004 Motor, Drum
- M005 Motor, Cassette Compartment

- M006 Motor, Reel Position
- M007 Motor, Fan
- M008 Motor, Fan
- M009 Motor, Treading

- PM1 Solenoid, Pinch
- PM2 Solenoid, T Brake
- PM3 Solenoid, S Brake
- RV1 Potentiometer, Threading

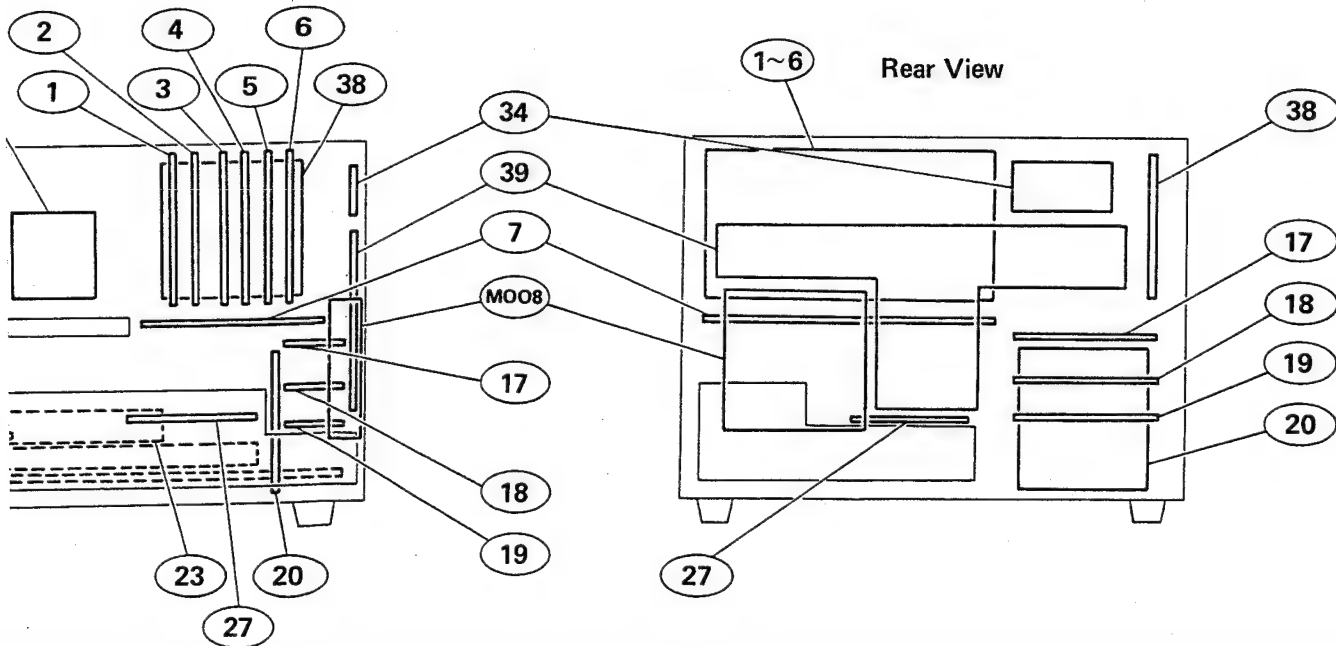

2-2. CABINET REMOVAL

Top cover removal

After sufficiently loosen the two screws of the top panel, then pull the top panel about 5 mm to the rear and lift it up.

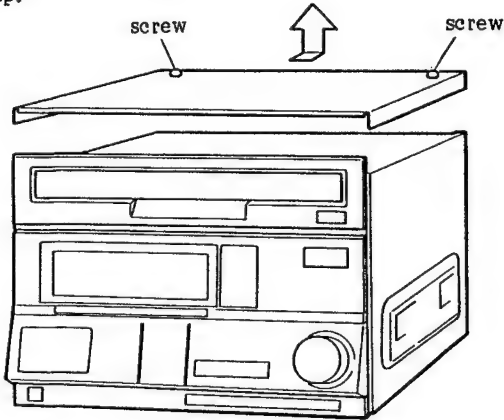

Side panels removal

After removing the top cover, remove the 10 screws and the 10 washers shown in the figure (+B4 x 10, five each left and right).

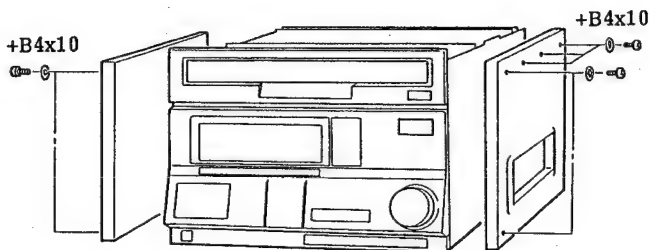

How to remove the escutcheon

After removing the top plate, side plates, and control panel, loosen the four set screws (+PSW3x8), shown in the figure, and then remove the escutcheon in the direction of the arrow.

Note: Remove the escutcheon carefully because the harness of such items as the EJECT button is attached to the inside of the escutcheon.

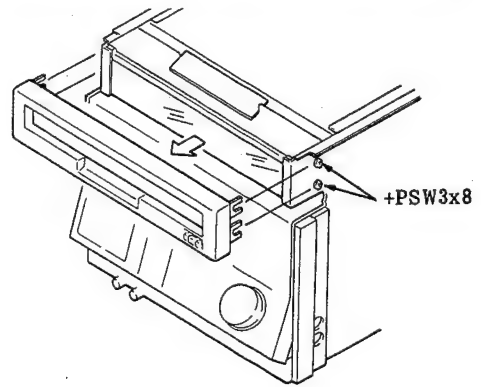

Note: When mounting the escutcheon, push it downward and then tighten the set screws.

Opening of connector panel

Adequately slacken the two screws of the rear panel shown in the figure, then open the connector panel.

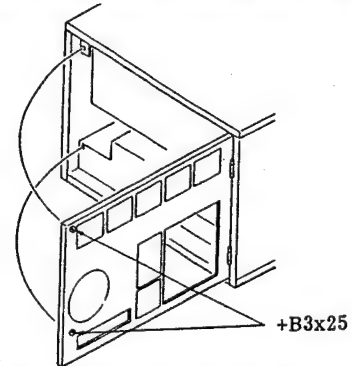

Removing the bottom panel of the function control panel

Remove the four screws (+PSW M3 x 8) shown in the figure. (Tightening torque: 8kg-cm)

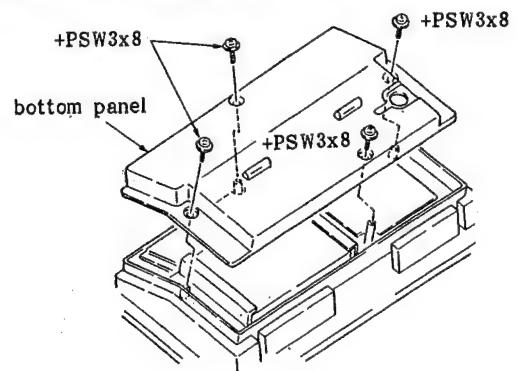

2-3. NOTES ON POWER UNIT

2-3-1. Primary Circuit & Electric Shock

The power supply section consists of the PS-138, the CT-74, and RE-32 boards, and also the primary side peripheral components. These parts are contained in a single case, forming a power supply unit. All of the CT-74 board and the shaded portion of the PS-138 board are on the primary side. Take care, therefore, not to receive an electric shock.

The heat sink on the primary side of the PS-138 board is also connected to the primary circuit.

Even after the power switch is turned OFF, a high voltage will remain on the shaded portion of the PS-138 board. Be careful, therefore, when handling the board.

PS-138 Board (component side)

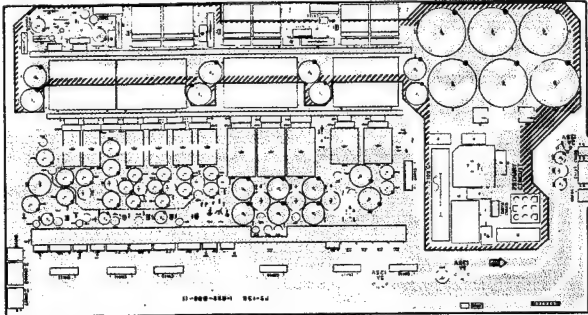

PS-138 Board (solder side)

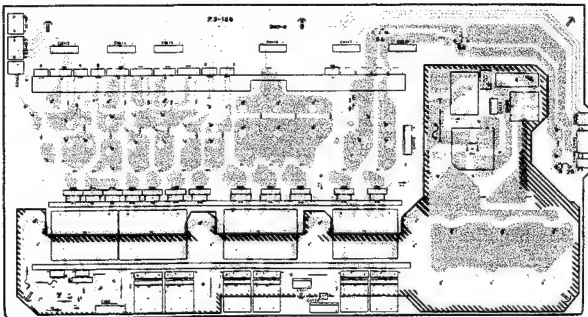

2-3-2. The Power Supply Removal

Note: Before performing work on the power supply, turn the power switch OFF and also unplug the power cord.

1. Remove the blank panel or control panel.
(For details, refer to Section 1-6, installing the function control panel.)
2. Remove the two screws (+PWH 3 x 6) and remove the harness clamp.
3. Disconnect connectors CN102, 104, 105, and 106, and also the 12 connectors indicated by the shading in the figure on the FC-37 board.
4. Remove the three screws indicated by the * marks in the figure.

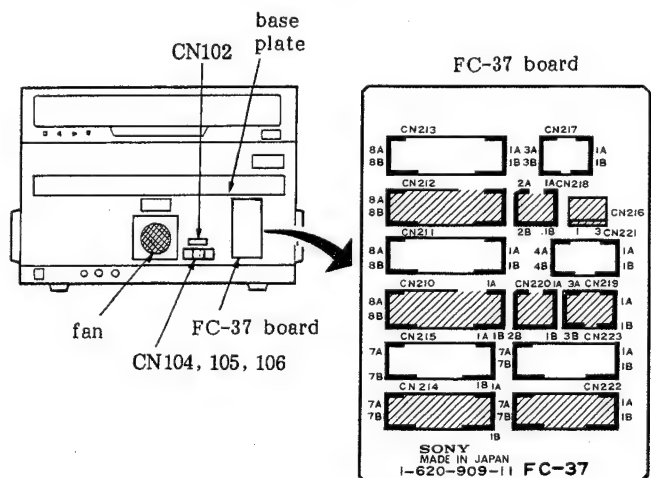
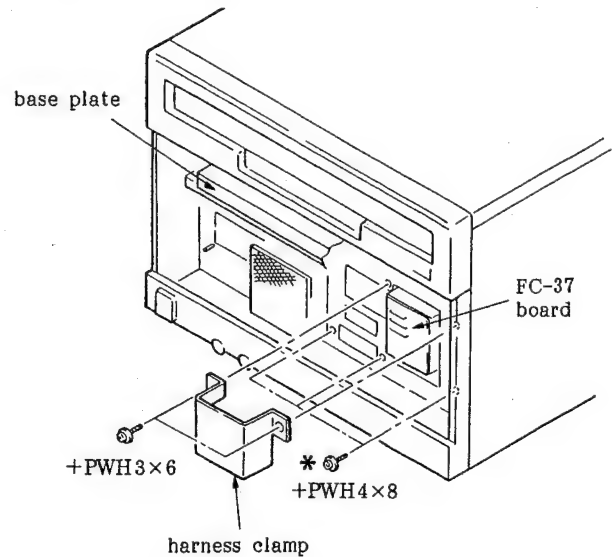

5. Open the connector panel.
6. Disconnect the connector CN931 from the PD-36 board and also the screw shown in the figure (+PWH 4 x 8).

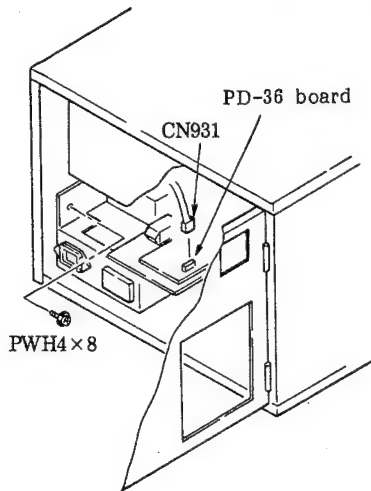

7. Withdraw the power supply about 10 cm, and disconnect connectors CN107, CN108, CN109, and CN124 shown in the figure.

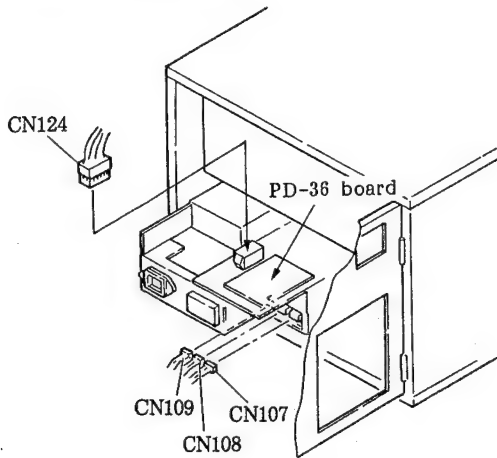

8. Withdraw the power supply entirely.

2-3-3. Checking the MD-43/PD-36/MB-137 Boards and Adjusting the Power Supply

Remove the power supply and place it alongside the unit as shown in the figure below. After removing the power supply, reconnect all of the connectors. Switch the power ON, and check the operation of the each board.

In this condition, the CT-74 and RE-32 boards can be adjusted from the holes in the left and right sides of the power supply cover. When performing adjustments which involve measuring voltages at the TP terminals, etc., however, remove the power supply cover according to Section 2-3-4. For details of the adjustment procedure, refer to Section 8 "POWER SUPPLY ALIGNMENT".

Caution:

Almost all of the circuits inside the power supply cover are on the primary side. When inserting an adjusting rod into the case, therefore, be very careful not to touch other conductive parts.

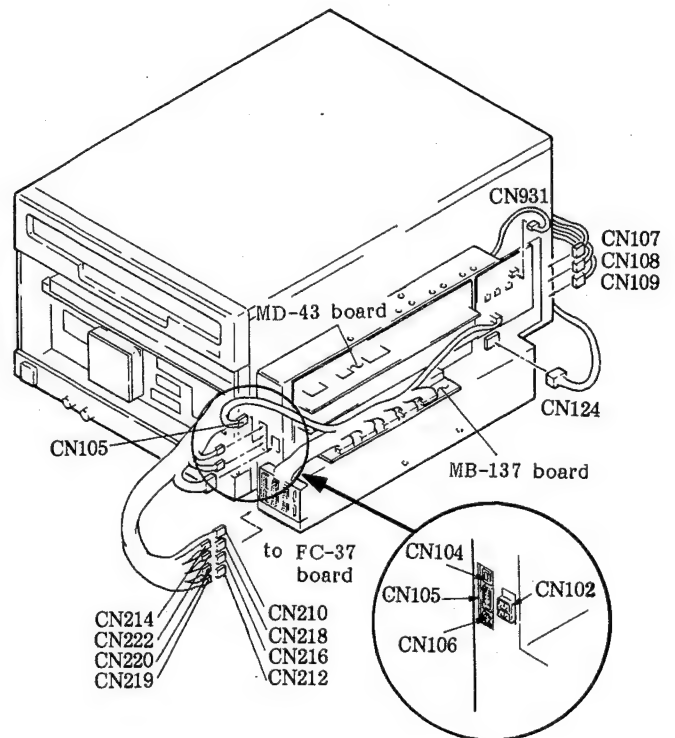



2-3-4. The PS-138/CT-74/RE-32 Boards Check

Note: Before performing work on the power supply unit, switch the power OFF and unplug the power cord. Even after the power switch is turned OFF, a high voltage will remain on the primary side circuit of the PS-138 board. Be careful, therefore, when handling the board.

1. After removing the power supply, disconnect CN211, 213, 215, 217, 221, and CN223 from the FC-37 board.
2. Disconnect CN930 from the PD-36 board.
3. Removing the MD-43 and MB-137 boards
Unscrews the four screws (+PSW 3 x 8).

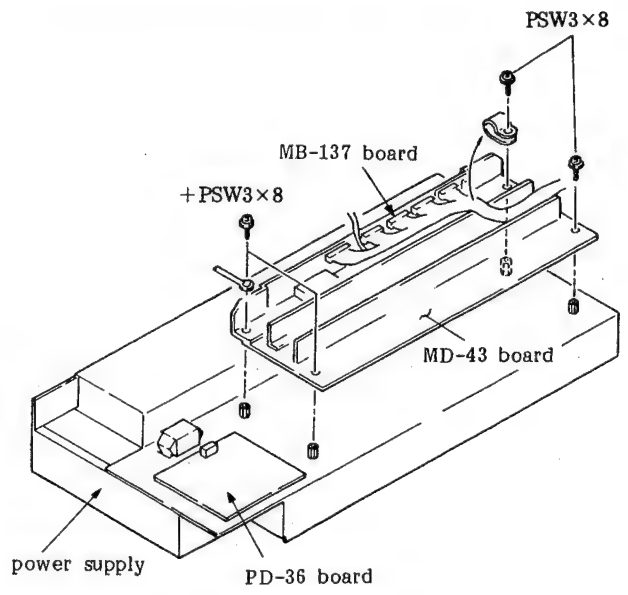
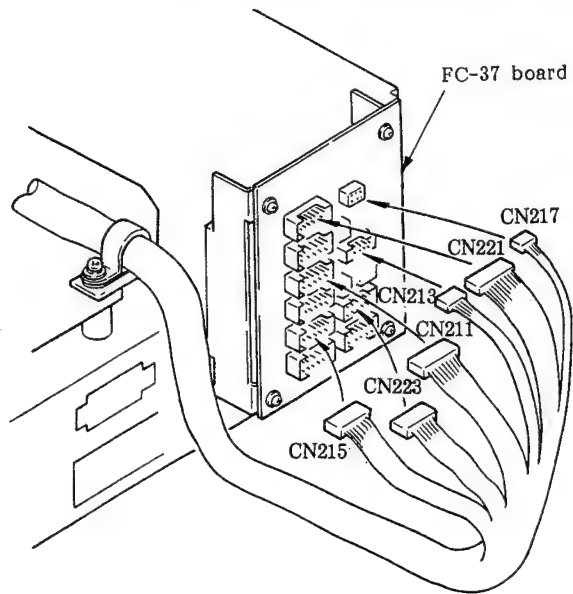

2. Disconnect CN930 from the PD-36 board.

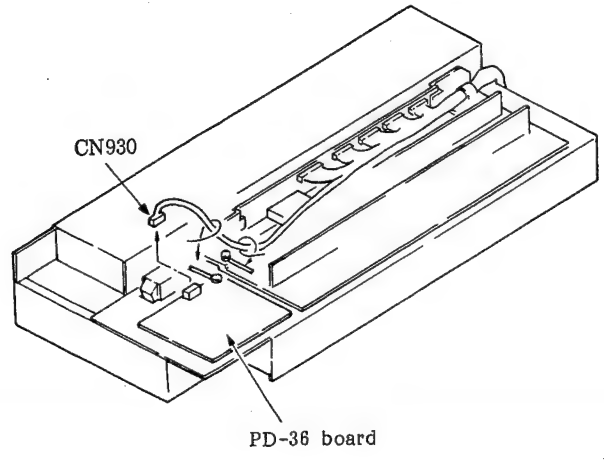

4. Removing bottom panel
Remove the six screws (+PWH 3 x 8).

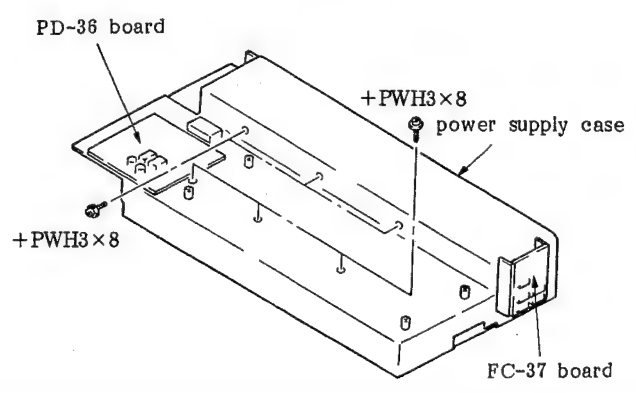

Remove the four screws (+PWH 3 x 6) shown in the figure, remove the bottom panel, then remove the six screws (+PSW 3 x 8).

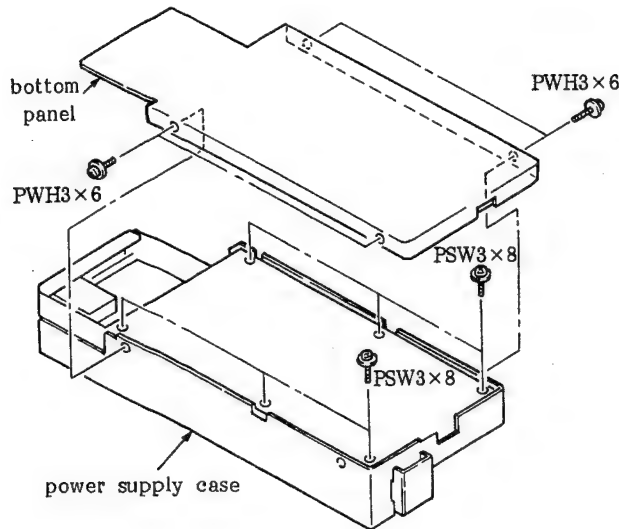

5. Removing the PS-138 board

Disconnect connectors CN102 and CN124 from the power supply case. Next, disconnect connector CN103 from the PS-138 board.

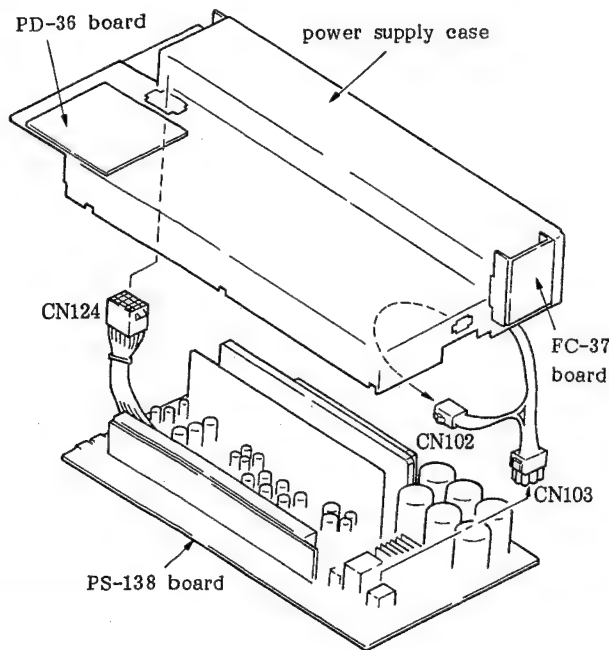

6. Re-connecting connectors

Install the MD-43 and MB-137 boards on the power supply case. Stand the power supply case as shown in the figure, and connect CN102 and CN930. Place the PS-139 board with the soldered side facing upward, arrange it as shown in the figure below, and connect CN103, 104, 105, 106, 107, 108, 109 and also CN124. Next, switch the power ON, and check the operation of the PS-138/CT-74/RE-32 boards. The operation of the power supply will not be affected if either the harness between the FC-37 board and the unit or CN931 is disconnected. In this case, however, the motors except the fan motors will not run when the power supply is switched ON. When checking the motor drive system, first ensure that the operation of the PS-138 board is normal, then check the MD-43 board.

Caution:

1. Most of the PS-138 board and all of the CT-74 board are in the primary circuit. When the board is in the position shown below, the primary side circuit is exposed. Take great care, therefore, not to receive an electric shock. Also, be very careful not to touch capacitors C5 to C10 on the PS-138 board because they will remain charged for a while even after the power is switched OFF.
2. If it is not possible to connect CN107, 108, and CN109, either stand the PS-138 board on edge with the RE-32 board on top of it or connect pin 5B of CN107 on the board to ground, leaving CN107, 108, and CN109 otherwise disconnected.

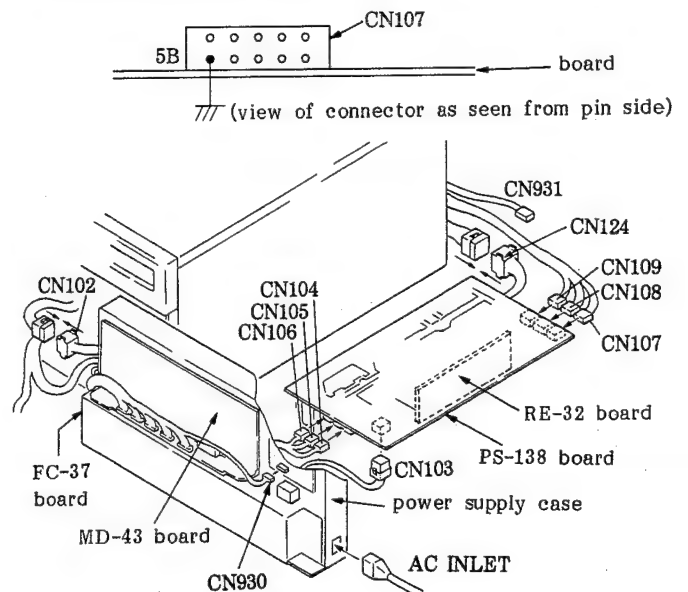



2-4. EXTRACTING/INSERTING PLUG-IN BOARDS

Wait switching off the power before extracting or inserting any of the plug-in boards.

Extracting the board

Pull up the eject levers in the board up in the direction of the arrow. Do not pull the board by grasping any of the components on it.

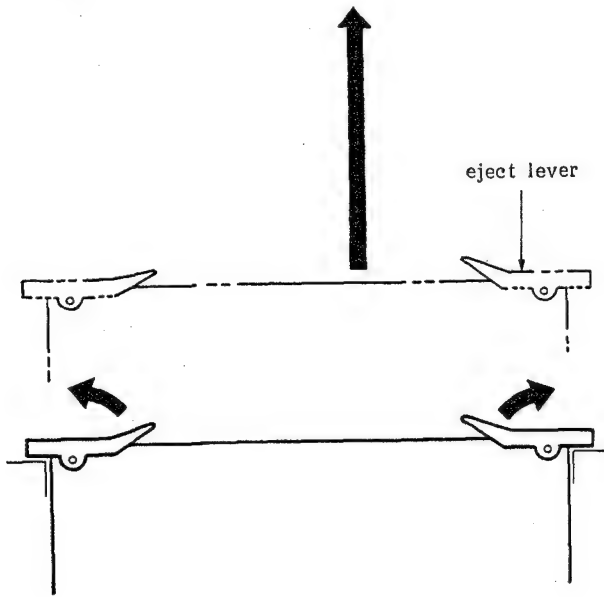

Inserting the board

Push down the eject levers as shown in the figure, then insert the board.

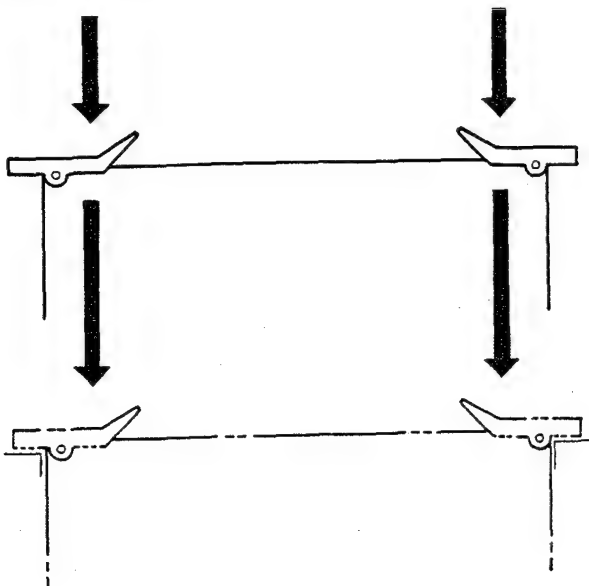

2-5. NOTES ON REPAIR PARTS

2-5-1. Notes on Repair Parts

(1) Safety Related Components Warning

Components identified by shading marked with \triangle on the schematic diagrams, exploded views and electrical spare parts list are critical to safe operation. Replace these components with Sony parts whose part numbers appear in this manual or in service bulletins and service manual supplements published by Sony.

(2) Standardization of Parts

Repair parts supplied from Sony Parts Center may not be always identical with the parts which actually in use due to "accommodating the improved parts and/or engineering changes" or "standardization of genuine parts".

This manual's exploded views and electrical spare parts list are indicating the part numbers of "the standardized genuine parts at present".

(3) Change of Parts

Regarding engineering parts changes, refer to Section E. "CHANGED PARTS".

(4) Stock of Parts

Parts marked with "o" SP (Supply Code) column of the spare parts list are not normally required for routine service work. Orders for parts marked with "o" will be processed, but allow for additional delivery time.

(5) Units for Capacitors, Inductors and Resistors

The following units are assumed in schematic diagrams, electrical parts list and exploded views unless otherwise specified.

Capacitors: μF

Inductors: μH

Resistors: ohm

2-5-2. Replacement Procedure of Chip Parts

Required Tools

Soldering iron 20W;

If possible, use the soldering-iron tip heat-controller at $270 \pm 10^\circ\text{C}$.

Braided wire;

SOLDER TAUL or equivalent

Sony Part No. 7-641-300-81

Solder; 0.6 mm dia. is recommended.

Tweezers

Soldering Conditions

Soldering iron temperature;

$270 \pm 10^\circ\text{C}$

Soldering time;

2 seconds per a pin

CAPACITOR

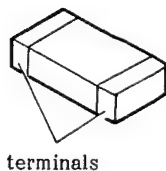

RESISTOR

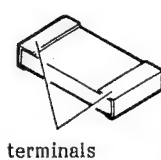

TRANSISTOR, DIODE

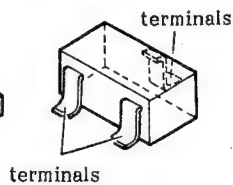

Replacement of Resistor and Capacitor

1. Place the soldering-iron tip onto the chip part and heat it up until the solder is melted. When the solder is melted, slide the chip part aside.
2. Make sure that there is no pattern peeling, damage and/or bridge around the desoldering positions.
3. After removing the chip part, presolder the area, in which the new chip part is to be placed, with a thin layer of solder.
4. Place new chip part in the desired position and solder both ends.

CAUTION: Do not use the chip part again once it has been removed.

Replacement of Transistor and Diode

1. Cut the terminals of the chip part with nippers.
2. Remove the leads cut as above.
3. Make sure that there is no pattern peeling, damage and/or bridge around the desoldering positions.
4. After removing the chip part, presolder the area, in which the new chip part is to be placed, with a thin layer of solder.
5. Place new chip part in the desired position and solder the terminals.

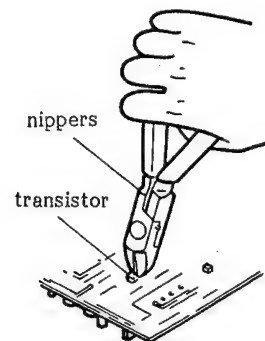

Replacement of IC

1. Using the braided wire, "SOLDER TAUL" Sony Part No. 7-641-300-81, remove the solder around the pins of the IC-chip to be removed.
2. While heating up the pins, remove the pins one by one using sharp-pointed tweezers.
3. Make sure that there is no pattern peeling, damage and/or bridge around the desoldering positions.
4. After removing the chip part, presolder the area, in which the new chip part is to be placed, with a thin layer of solder.
5. Place new chip part in the desired position and solder the pins.



2-5-3. Replacing the Backup Battery

The following boards are provided with a RAM backup battery. When necessary, replace it using the procedure described below:

When replacing the RAM backup battery, be sure to use the battery listed in the parts list.

1. CP-106 Board (control panel)
2. SY-69 Board (card rack)
3. IF-138 Board (interface)

(1) How to replace the battery

1. The CP-106 board

When the battery on the CP-106 board reaches the end of its life, the message "BATTERY EMPTY/BACKUP DATA LOST" will be displayed on the control panel. In this case, switch the DVR-1000 OFF, remove the board concerned, and replace the battery with a new one.

2. The SY-69 Board

When the battery on the SY-69 board reaches the end of its life, the message "BACKUP ERROR" will be displayed on the control panel. In this case, switch the DVR-1000 OFF, remove the board concerned, and replace the battery with a new one.

3. The IF-138 Board

When the battery on the IF-138 board reaches the end of its life, no message will be displayed on the control panel, hence it is necessary to replace this battery periodically using the operating time of the unit as a rough guide. The standard replacement interval is 4 or 5 years.

Replace the battery using the following procedure:

- ① Turn the switch of the DVR-1000 ON, then after a few seconds turn it OFF again and remove the board.
- ② Replace the battery, taking care not to touch any conductive parts other than the battery. Even after the battery has been removed, the data will be retained for several days, however the battery should be replaced as quickly as possible.

Note: Unless the above procedure is followed, all of the RAM data will be reset to "0".

(2) After replacing a battery

1. CP-106 Board

- ① Switch the DVR-1000 ON while pressing **F** and **CLR** keys on the 20-key section.
- ② The INITIAL screen will appear, and will flash at intervals of about 0.5 seconds. Confirm this, then release the **F** and **CLR** keys.

2. SY-69 Board

- ① Confirm that the SY-69 board is installed, then switch the DVR-1000 ON.
- ② Press the RESET switch (S1) of the SP-01 board while pressing the SETUP switch (S1) of the SY-69 board.
- ③ Release the RESET switch (S1) of the SP-01 board.
- ④ Wait for 2 to 3 seconds then release the SETUP switch (S1) of the SY-69 board.

Note: The "BACKUP ERROR" error message will appear when the battery on one of the boards shown below reaches the end of its life:

DVR-1000: SY-69 board

DVPC-1000: IF-139 board

If the error message remains despite replacing the battery on one board with a new one, either the battery contact is faulty or the battery on the other board reaches the end of its life.

2-5-4. Replacing Flexible Wire (4P, 26P)

A 4P cable is used in the cassette-up compartment, and one 26P cable is used on each of the S and T Reel Motor. When handling the cable, be very careful not to bend it as this will markedly reduce its life.

Disconnecting the cable

- ① Pull portion **(A)** of the connector to the cable side, as shown in the figure.

Caution: Under no circumstances pull the cable first.

- ② Disconnect the cable.

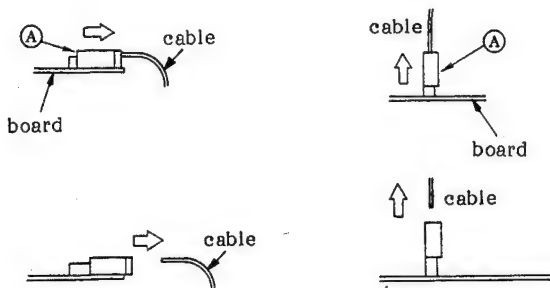

Connecting the cable

- ① Identify the front and back faces of the cable, then insert the cable into the connector.

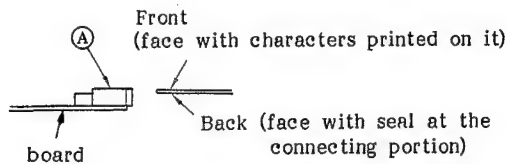

- ② Insert portion **(A)** of the connector.

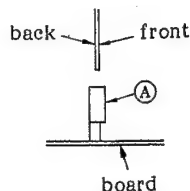

2-5-5. Replacing the EL Panel (Function Control Panel)

This is a block replacement part. If it breaks down, trace the cause of the breakdown and have it repaired. The panel contains high voltage parts. Under no circumstances, therefore, attempt to disassemble it.

- (1) Remove the bottom panel. (See Section 2-2. "CABINET REMOVAL".)
- (2) Removing the EL panel.
Remove the four screws (PSW 3 x 6) shown in the figure, then disconnect CN5.
- (3) Install the new EL panel and screw the bottom panel in place.

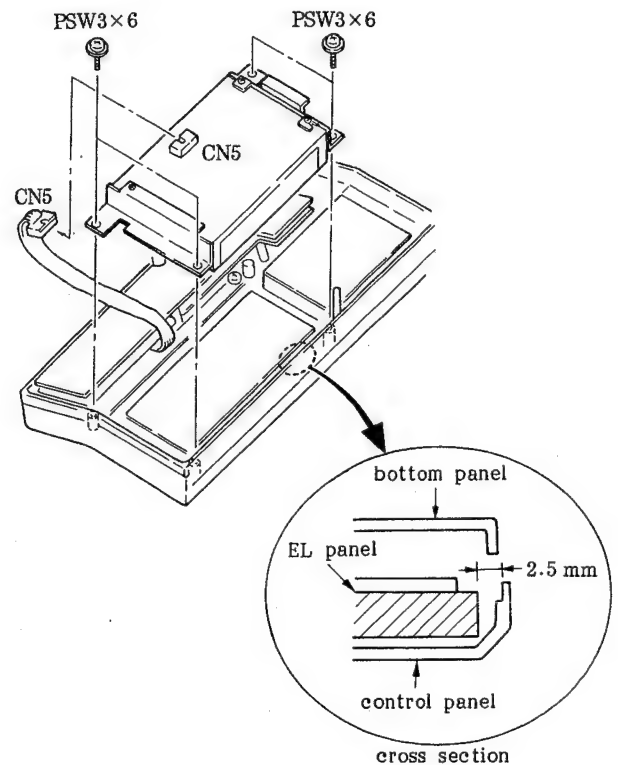

2-5-6. Servicing Board in Head Drum

The recording/playback module board and hybrid ICs are mounted on the scanner in the drum.

The dynamic balance of the scanner has been completely adjusted with this board in the circuit. For this reason, when servicing the unit do not under any circumstances remove the module board, remove components from it, or add components to it. (Also, do not remove solder from the board, or add solder to it.)

The shield cover installed on the outside of the playback module board must not be removed.



**2-6. METHOD OF REMOVING CASSETTE TAPE WHEN
EITHER IT CANNOT BE EJECTED OR CASSETTE-
UP COMPARTMENT DOES NOT RISE**

If either the cassette cannot be ejected or the cassette-up compartment does not rise up due to some trouble or other, first carry out the following procedure then remove the cassette:

1. Remove the top cover and the control panel.
2. Rotate the gear coupling by hand in the direction of the arrow and move each guide to the unthreading position. The tape will remain at the threading position.

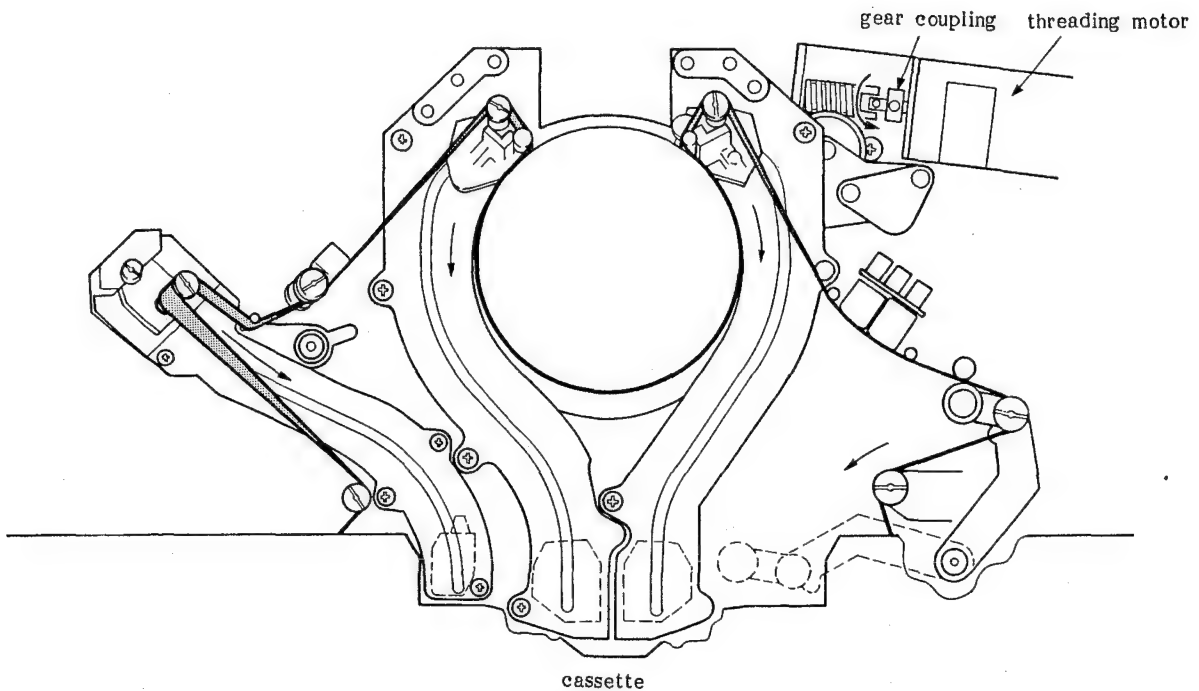

3. Place the hand inside the opening at the bottom of the cassette loading port, and rotate the bottom of the S side reel motor by hand to take up the tape protruding from the cassette. At this time, take care not to damage the tape which remains in the unit.

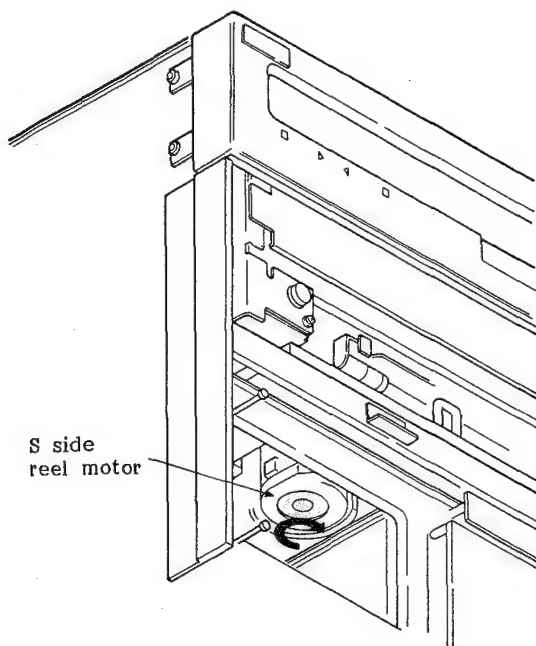

5. Remove the cassette tape from the cassette compartment.
6. Check the cause of the trouble and carry out repair.

4. Leaving the cassette compartment installed on the VTR unit, rotate the driving wheel at the left front to the right side to raise the cassette compartment.

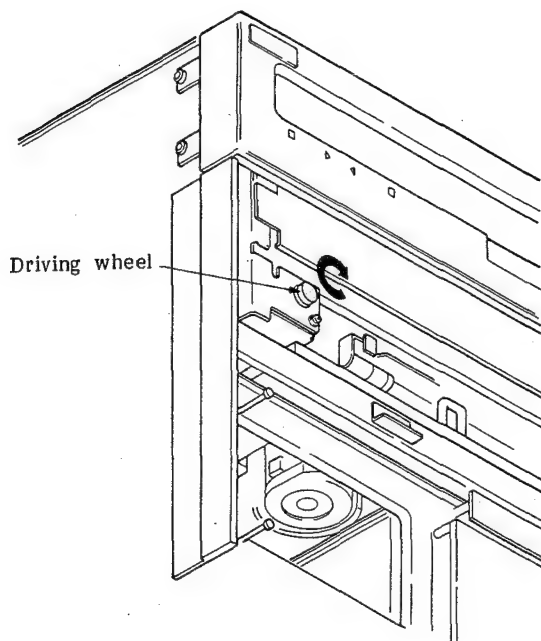



2-7. ALIGNMENT TAPE DR-5-1A and DR-5-1B

The DR-5-1A alignment tape is for 525/60 system.

The DR-5-1B alignment tape is for 625/50 system.

The following signals are recorded on it.

| TIMER min.sec | CUE | AUDIO | | VIDEO | |
|------------------|---------------|----------------------|--------------------------|---|------------------------------|
| | | CONTENTS (CH1/2/3/4) | USE | CONTENTS | USE |
| 0.00 | BLANK | BLANK | | A ch; FRAME RECORD SIGNAL B/C/D ch; BLANK | CTL POSITION CHECK |
| 2.00 | BLANK | BLANK | | A ch; 10MHz B/C/D ch; BLANK | TAPE PATH CHECK |
| 6.00 | BLANK | BLANK | | A ch; 10MHz B/C/D ch; 20MHz | TRACKING CHECK |
| 8.00 | BLANK | BLANK | | A ch; PG ADJUSTMENT SIGNAL B/C/D ch; BLANK | PG POSITION CHECK |
| 10.00 | BLANK | BLANK | | A ch; DIGITAL COLOR BAR B/C/D ch; BLANK | PB EQUALIZER CHECK |
| 15.00 | BLANK | BLANK | | A ch; POLARITY CHECK PATTERN B/C/D ch; BLANK | POLARITY CHECK |
| 16.00 | 1KHz, -20VU | 1KHz, -20VU | LEVEL CHECK | COLOR BAR (DIGITAL) | D/A GAIN, RGB PHASE CHECK |
| 16.50 | | | | | |
| 17.00 | 10KHz, 0VU | 1KHz, 0VU | LEVEL CHECK | | |
| 17.50 | | | | LINEARITY (DIGITAL) | D/A LINEARITY CHECK |
| 18.00 | 1KHz, -10VU | 1KHz, +20VU | FREQUENCY RESPONSE CHECK | | |
| 18.50 | | | | | |
| 19.00 | 50Hz, -10VU | BLANK | FREQUENCY RESPONSE CHECK | | |
| 19.50 | | | | MULTI BURST (DIGITAL) | D/A FREQUENCY RESPONSE CHECK |
| 20.00 | 100Hz, -10VU | 20Hz, 0VU | FREQUENCY RESPONSE CHECK | | |
| 20.50 | | | | | |
| 21.00 | 200Hz, -10VU | 40Hz, 0VU | FREQUENCY RESPONSE CHECK | | |
| 21.50 | | | | SHUFFLE THROUGH COLOR BAR (DIGITAL) | PB SYSTEM CHECK |
| 22.00 | 300Hz, -10VU | 100Hz, 0VU | FREQUENCY RESPONSE CHECK | | |
| 22.50 | | | | | |
| 23.00 | 500Hz, -10VU | 10KHz, 0VU | FREQUENCY RESPONSE CHECK | | |
| 23.50 | | | | ZONE PLATE (ANALOGUE) | CONCEALMENT CHECK |
| 24.00 | 3KHz, -10VU | 12KHz, 0VU | FREQUENCY RESPONSE CHECK | | |
| 24.50 | | | | | |
| 25.00 | 5KHz, -10VU | 16KHz, 0VU | FREQUENCY RESPONSE CHECK | | |
| 25.50 | | | | | |
| 26.00 | 7.5KHz, -10VU | 20KHz, 0VU | FREQUENCY RESPONSE CHECK | | |
| 26.50 | | | | TURN TABLE PICTURE (ANALOGUE) | FF/REW/SLOW MOTION CHECK |
| 27.00 | 10KHz, -10VU | BLANK | | | |
| 27.50 | | | | | |
| 28.00 | 12KHz, -10VU | BLANK | | | |
| 28.50 | BLANK | BLANK | | | |
| 32.00 | | | | | |

2-8. MAINTENANCE TOOLS/FIXTURES

Note: The asterisked (*) tools are included in the tool kit of the DVR-1000.

Extender, EX-129 SONY Part Number A-6001-011-A
This board is used in checking and repairing plug-inboards that are housed in the card rack. A sheet of extender is provided with the DVR-1000.

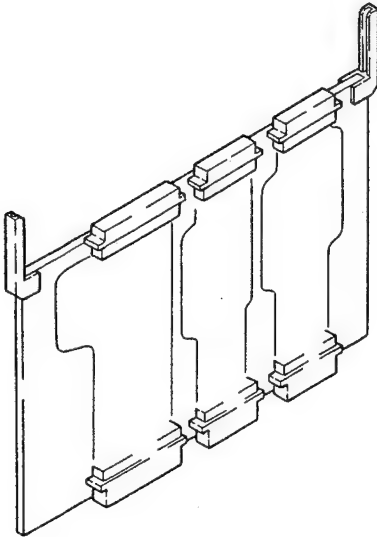

Extender, EX-131 Sony Part Number A-6001-008-A
Used for check or repair of the plug-in boards accommodated in the card rack. A single EX-131 board is provide with the DVPC-1000.

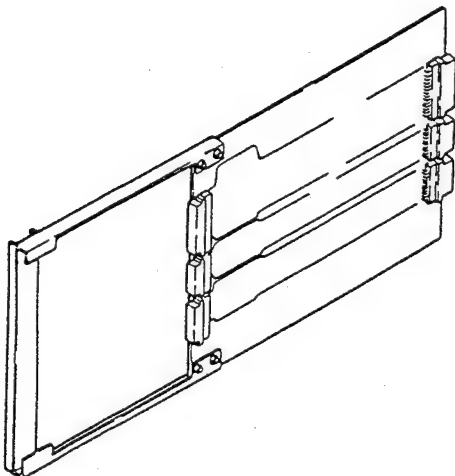

Tool Kit

SONY Part Number J-6253-260-A

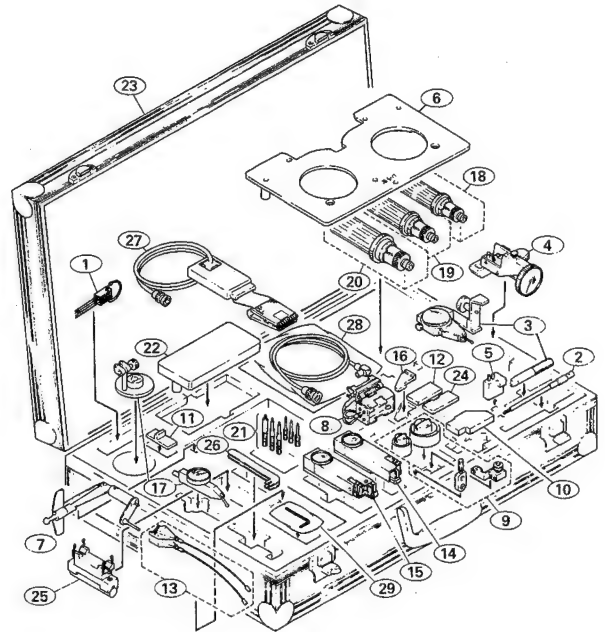

| Parts No. | Description |
|-----------|--|
| 1 | J-6152-450-A Wire Clearance Gauge Set |
| 2 | J-6251-090-A Torque Driver Bit |
| 3 | J-6251-110-A Scanner Eccentricity Adj. Gauge |
| 4 | J-6251-120-A Head Projection Measurement Gauge |
| 5 | J-6251-160-A Guide Rail Adj. Tool |
| 6 | J-6251-170-B Reel Plate (M) |
| 7 | J-6251-210-A Pinch Roller Adj. Tool |
| 8 | J-6251-850-A Pinch Roller Check Tool |
| 9 | J-6251-870-A S-tension Arm Output Check Tool |
| 10 | J-6252-190-A Reel Table Height Adj. Tool |
| 11 | J-6252-200-A S-plate Adj. Tool |
| 12 | J-6252-300-A Flat-plate |
| 13 | J-6252-310-A PRT Harness Guide |
| 14 | J-6252-360-A Guide S5 Zenith Check Tool |
| 15 | J-6252-370-A Guide T6 Zenith Check Tool |
| 16 | J-6252-380-A Guide S4 Height Adj. Tool |
| 17 | J-6252-400-A Reel Table Shaft Adj. Block |
| 18 | J-6252-510-A Torque Driver 6kg/cm |
| 19 | J-6252-520-A Torque Driver 12kg/cm |
| 20 | J-6252-530-A Torque Driver 26kg/cm |
| 21 | J-6252-540-A Bits Set for Torque Driver |
| 22 | J-6252-730-A Slant Check Master |
| 23 | J-6253-020-A Carrying Case |
| 24 | J-6253-030-A Guide T6 Width Check Gauge |
| 25 | J-6253-180-A Capstan Shaft Adj. Tool |
| 26 | J-6253-300-A Tension Arm Bending Tool |
| 27 | J-6263-470-A Roving DAC |
| 28 | J-6264-360-A BNC-UM Cable |
| 29 | 7-700-736-01 L-shaped Hexagonal Wrench (1.27) |



Alignment Tape SONY Part Number
 DR-5-1A for 525/60 System 8-960-070-01
 DR-5-1B for 625/50 System 8-960-070-51
 Refer to section 2-7 for the recorded contents.

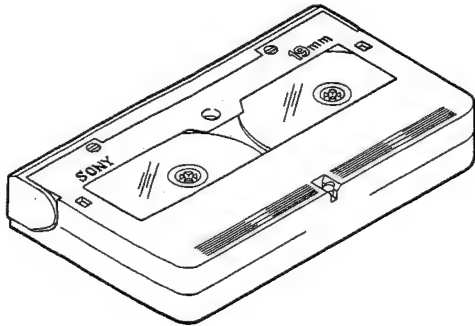

Dummy Cassette SONY Part Number
 Cassette for in switch 'OFF' J-6252-170-A
 Cassette for in switch 'ON' J-6252-180-A
 These cassettes are used for in switch positioning.

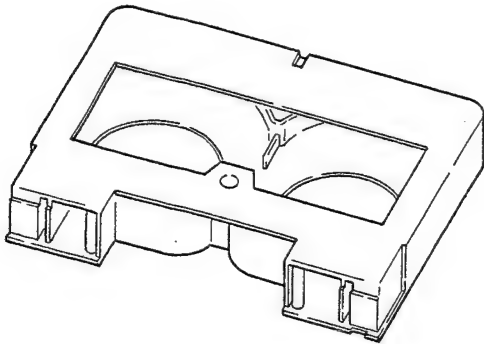

Thickness Gauge SONY Part Number J-6041-670-A
 This gauge is used for positioning adjustment of mechanism parts.

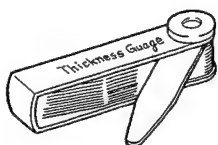

| Thickness (mm) | | |
|----------------|------|------|
| 0.03 | 0.04 | 0.08 |
| 0.09 | 0.10 | 0.11 |
| 0.12 | 0.13 | 0.14 |
| 0.15 | 0.20 | 0.25 |
| 0.30 | 0.35 | 0.40 |
| 0.45 | 0.50 | 0.60 |
| 0.75 | 0.80 | 0.90 |
| 1.00 | | |

*
Torque Driver Bit SONY Part Number J-6251-090-A
 This bit is used to tighten the drum attaching screws.

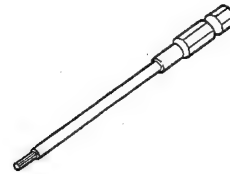

*
Scanner Eccentricity ADJ. Gauge
 SONY Part Number J-6251-110-A
 This gauge is used for eccentricity adjustment when the scanner assembly is replaced.

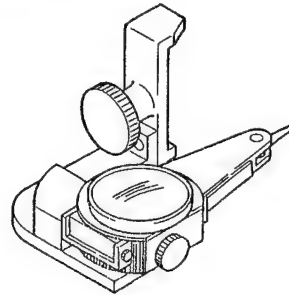

*
Head Projection Measurement Gauge
 SONY Part Number J-6251-120-A
 This gauge is used to measure the head projection.

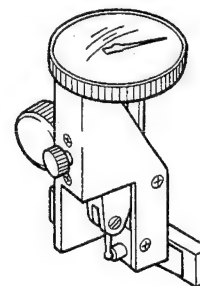

*
Guide Rail ADJ. Tool SONY Part Number J-6251-160-A
 This tool is used for guide rail positioning at S side.

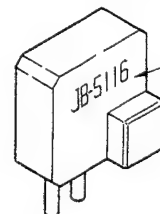

Stamped with "JB-5116"

*
Reel Plate (M) SONY Part Number J-6251-170-B
 This plate is used to adjust the height of the reel table.

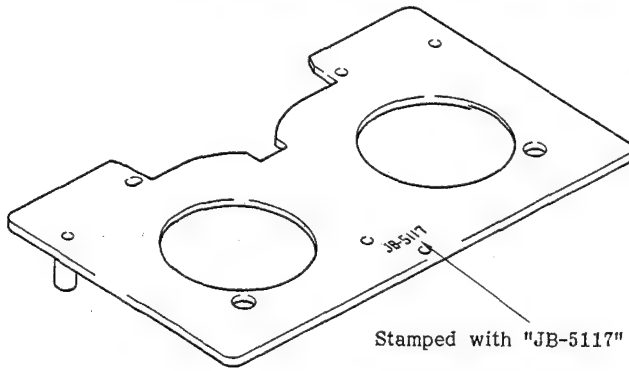

*
Pinch Roller ADJ. Tool SONY Part Number J-6251-210-A
 This tool is used to measure the pinch roller.

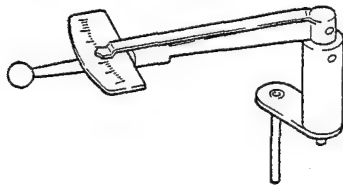

*
Pinch Roller Check Tool SONY Part Number J-6251-850-A
 This tool is used to check the azimuth of the pinch roller link. Use four UM3 batteries for this tool.

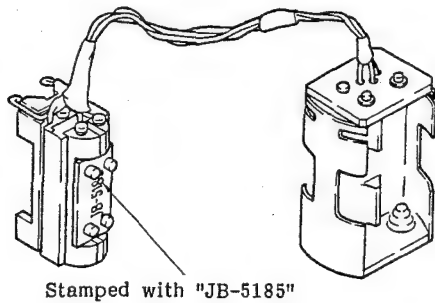

*
S-tension Arm Output Check Tool SONY Part Number J-6251-870-A
 This tool is used to measure the tension of the S-tension arm.

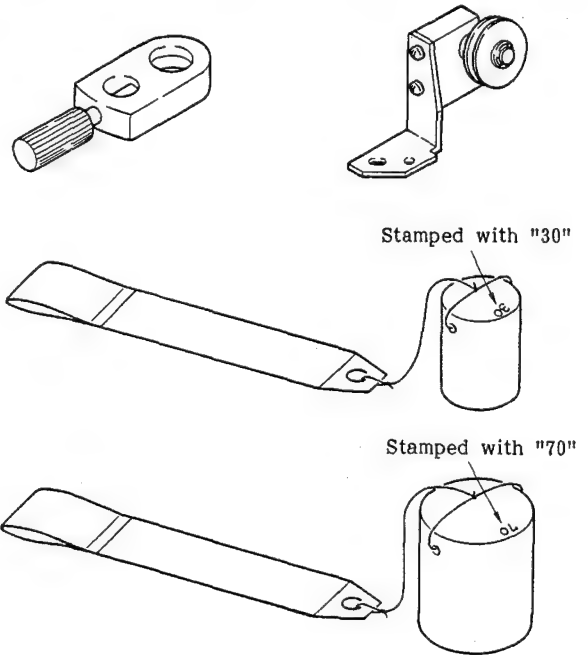

*
Reel Table Height ADJ. Tool SONY Part Number J-6252-190-B
 This tool is used to adjust the height of the reel table and the guide S5 and the azimuth of the pinch roller.

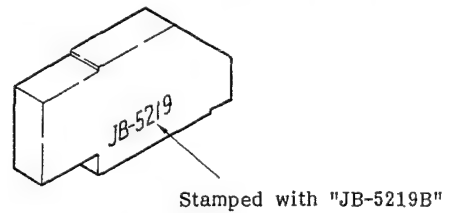

*
S-plate ADJ. Tool SONY Part Number J-6252-200-A
 This tool is used to adjust the slant of the S drawer slider and the tension regulator.

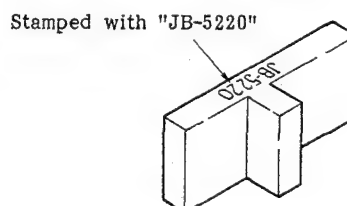

* **Flat-plate** SONY Part Number J-6252-300-A
This plate is used to check the inclination of the audio head.

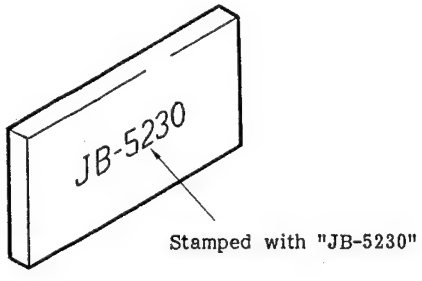

* **PRT Harness Guide** SONY Part Number J-6252-310-A
This guide is used to guide the harness in the drum.

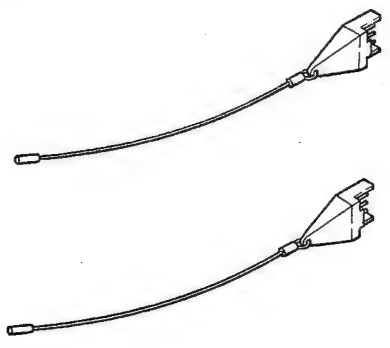

* **Guide S4 Height ADJ. Tool** SONY Part Number J-6252-380-A
This tool is used to adjust the height of guide S4.

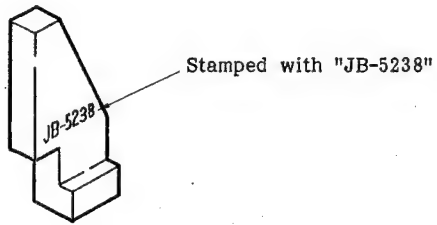

* **Reel Table Shaft ADJ. Tool** SONY Part Number J-6252-400-A
This tool is used for vertical adjustment of the reel shaft.

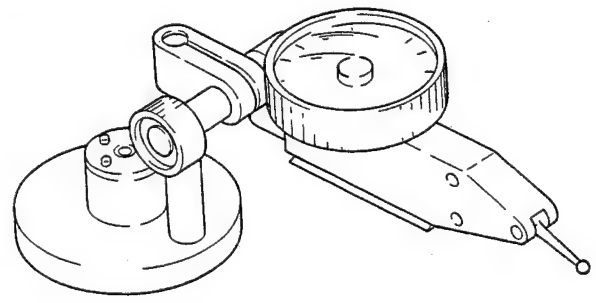

* **Torque-Driver**
6kg-cm SONY Part Number J-6252-510-A
12kg-cm SONY Part Number J-6252-520-A
26kg-cm SONY Part Number J-6252-530-A

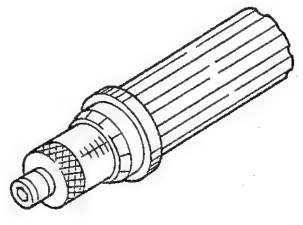

* **Bits Set for Torque Driver** SONY Part Number J-6252-540-A

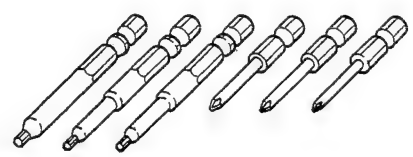

Cleaning Cassette, DCM-75CL
Employed for cleaning the head.

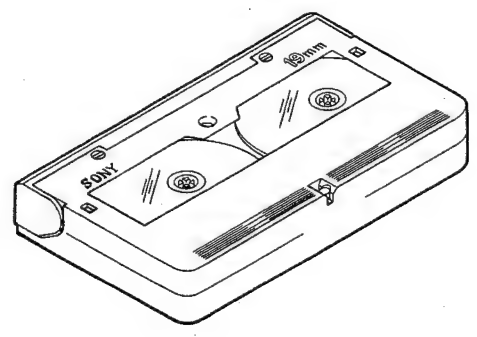

SONY Grease SGL-501

SONY Part Number 7-662-001-62

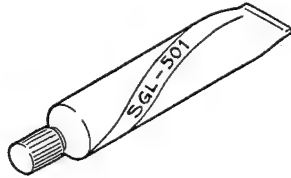

MOLITON Grease No. 320

SONY Part Number 7-662-001-41

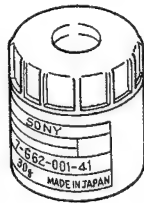

Slant Check Master**

SONY Part Number J-6252-730-A

This tool is used to calibrate the S5 and T6 guide slant check gauges.

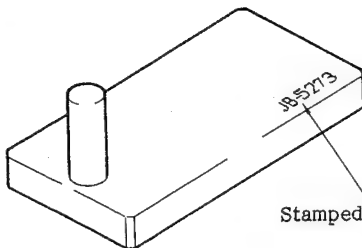

Stamped with "JB-5273"

Guide S5 Zenith Check Tool**

SONY Part Number J-6252-360-A

This gauge is used to check the slant of the S5 guide.

Note: Make sure to adjust this tool with the slant check master (J-6252-730-A) before using it. (Refer to Section 2-9.)

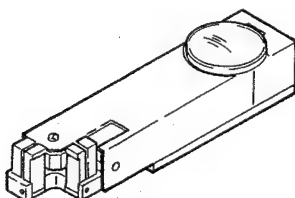

Guide T6 Zenith Check Tool**

SONY Part Number J-6252-370-A

This gauge is used to check the slant of the T6 guide.

Note: Make sure to adjust this tool with the slant check master (J-6252-730-A) before using it. (Refer to Section 2-9.)

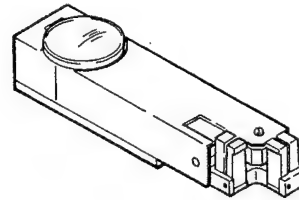

Tension Arm Bending Tool**

SONY Part Number J-6253-300-A

or J-6041-650-A

Serves to adjust inclination of the tension regulator guide.

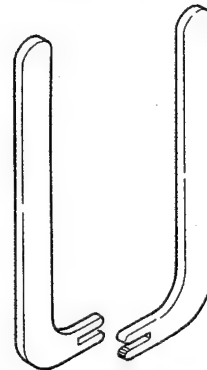

Guide S5 Zenith Check Tool**

SONY Part Number J-6252-360-A

This gauge is used to check the slant of the S5 guide.

Note: Make sure to adjust this tool with the slant check master (J-6252-730-A) before using it. (Refer to Section 2-9.)

Wire Clearance Gauge Set**

SONY Part Number J-6152-450-A

Used to adjust clearance between mechanical parts.

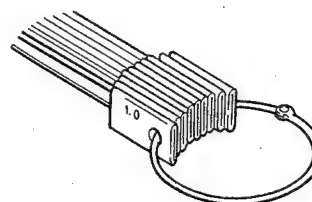

Thickness (mm)

- 0.1 0.2
- 0.3 0.4
- 0.5 0.6
- 0.7 0.8
- 0.9 1.0



Dental Mirror

SONY Part Number 7-723-902-00

Used for watching tape transport.

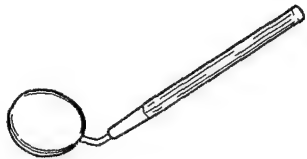

*

Capstan Shaft Straightening Tool

SONY Part Number J-6253-180-A

Used to straighten the capstan motor shaft.

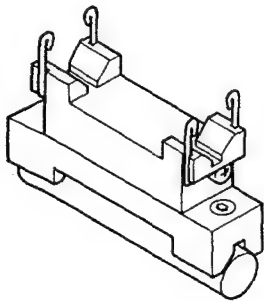

*

Guide T6 Gauge

Sony Part Number J-6253-030-A

Used to adjust the upper/lower flange width of the T6 guide.

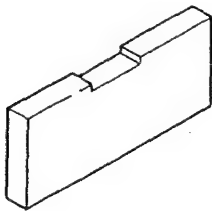

*

BNC-UM Cable

SONY Part Number J-6264-360-A

Used for observation of RF waveform.

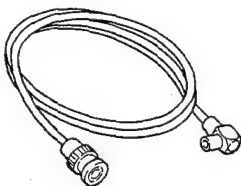

*

Roving DAC

SONY Part Number J-6263-470-A

Note: This part includes a single cable for conversion between the mini RF plug and BNC plug (BNC-UM cable: J-6264-360-A, 1m).

Used for check, troubleshooting, etc. of the digital signal processing circuit.

The roving DAC is used mounted to an 8-bit D type flip-flop IC such as LS273/573 type (20-pin). It samples discretionary 8-bit parallel data in the digital circuit and output the data as an analog signal via D/A conversion.

By observing the output signal with an oscilloscope or the like, operation check and troubleshooting of the digital circuit are easily achievable.

For details of usage, refer to 2-6 of the DVPC-1000 maintenance manual (VOL-1).

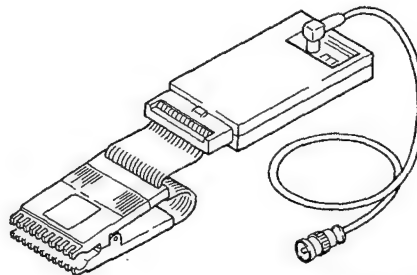

BNC-UM cable

Cleaning Band

SONY Part Number 3-735-152-01

Used to clean the slider guide block.



Microscope Attachment Sony Part Number J-6253-420-A
Head Chip Microscope Sony Part Number J-6252-210-A
Used to observe the head chip.
Microscope attachment
Head chip microscope

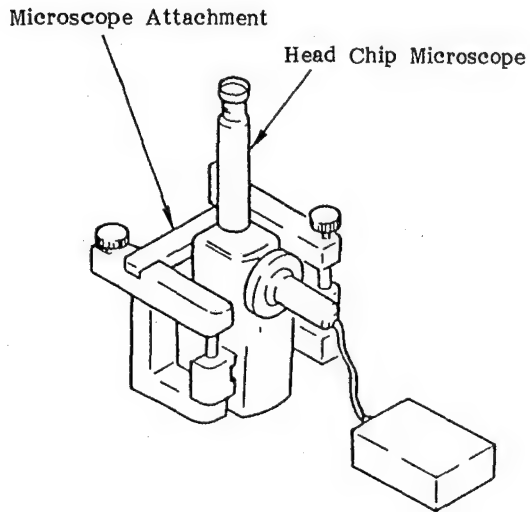



2-9. CALIBRATION METHOD OF THE S5/T6 ZENITH CHECK TOOLS

- When the S5/T6 zenith check tools are used, be sure to calibrate them by using the zenith check master.
- Carefully measure the guide slant so that the probe does not touch either upper or lower flange, as shown in the figure below.

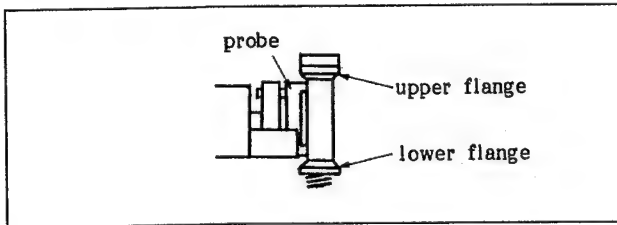

2-9-1. Calibration of the S5 Zenith Check Tool

1. The following figure shows the relation between the the guide slant and the fluctuation of the needle of the dial gauge.

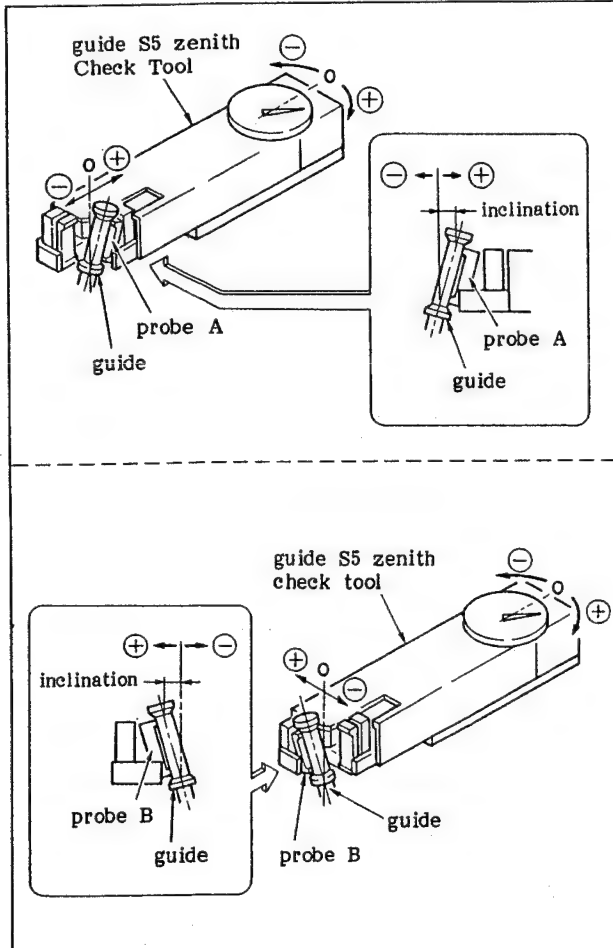

2. Push probe A of the S5 slant check tool, shown in the figure below, lightly against the slant check master. Verify that the needle of the dial gauge is pointing to "0" at this time. If it is not, adjust set screw A shown in the figure.

Note: Push probe A against the slant check master so that the center line of the cylinder of the slant check master is aligned with the center line of the probe.

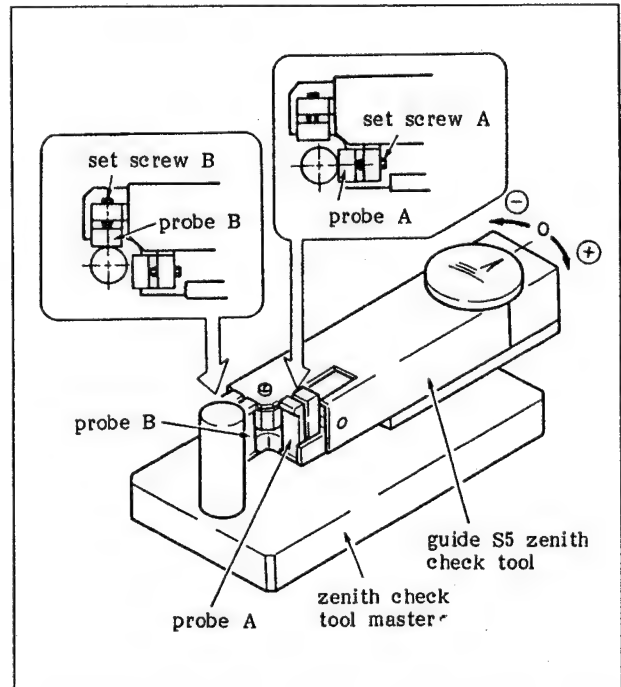

3. Push probe B lightly against the slant check master similarly to Step 2 and verify that the needle of the dial gauge is pointing to zero. If it is not, adjust set screw B.

2-9-2. Calibration of the T6 Zenith Check Tool

1. The following drawing shows the relation between the guide slant and the fluctuation of the needle of the dial gauge.

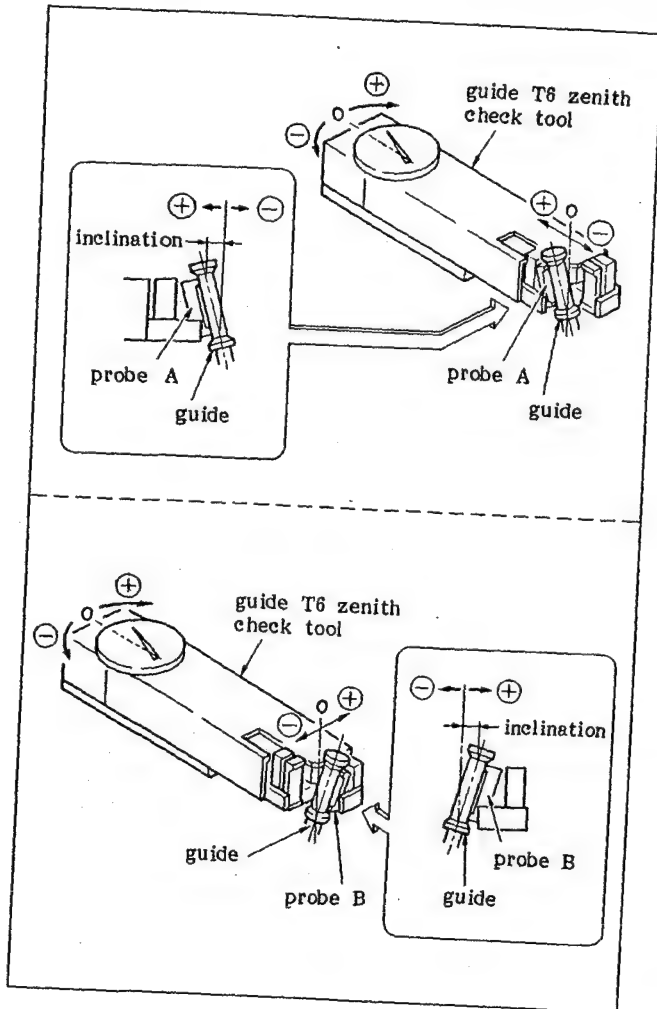

2. Push the probe A of the T6 zenith check tool, shown in the figure below, lightly against the zenith check master. Verify that the needle of the dial gauge is pointing to "0" at this time. If it is not, adjust the set screw A shown in the figure.

Note: Push probe A against the zenith check master so that the center line of the cylinder of the zenith check master is aligned with the center line of the probe.

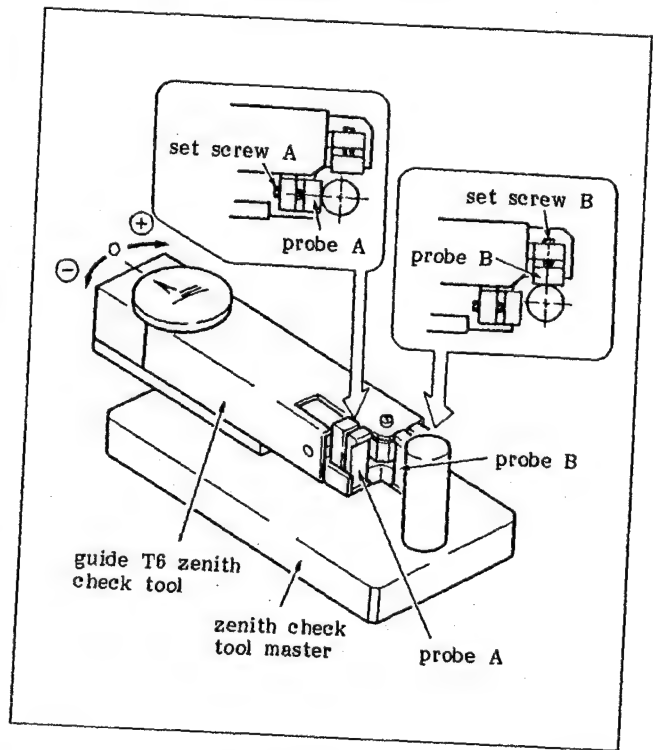

3. Push probe B lightly against the zenith check master similarly to Step 2 and verify that the needle of the dial gauge is pointing to "0". If it is not, adjust set screw B.



2-10. FUNCTION OF SWITCHES, JUMPERS AND LEDs

2-10-1. RF-15 Board

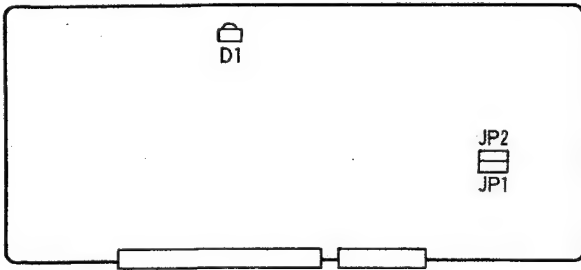

D1: ADV EN indicator (green)

This lights under capstan servo lock conditions.

JP1/2: ADVANCE HEAD select jumpers

Normally, JP2 is shorted.

When JP1 is shorted, the equalizer ICs (IC5, 6, 7 and 8) at the playback system operate in the advance head playback mode at all times.

2-10-2. AE-05 Board

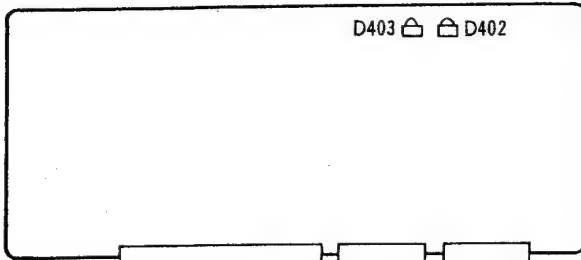

D402: CTL EXIST indicator (green)

This lights when the CTL PB level is more than 1.4Vp-p.

D403: TC EXIST indicator (green)

This lights when the TIME CODE PB level is more than 1.0Vp-p.

2-10-3. SP-01 Board

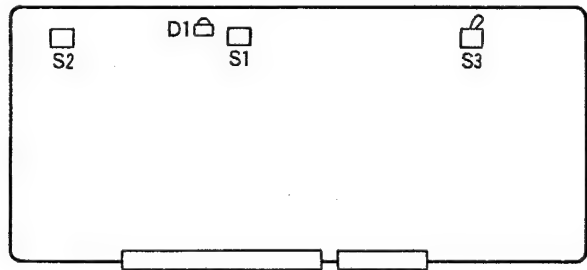

D1: W.DOG indicator (green)

This lights when the CPU is hangup. Press the SYSTEM RESET switch S1/SP-01 when this lamp has lighted.

S1: SYSTEM RESET switch

This resets all the CPUs on the SP-01, SY-69 and RS-23 boards to the power-on status.

S2: NOV RAM WRITE switch

This transfers data written in the RAM of NOV RAM into the nonvolatile memory area. For details on the data transfer, refer to the section 3 "TEST MENU".

S3: MOTOR ALL OFF switch

This switches off the power which is supplied to all the motors. When S3 is set to the HOLD position, power is not supplied to the motors. Normally, S3 is set to the NORMAL position.

2-10-4. SY-124 Board

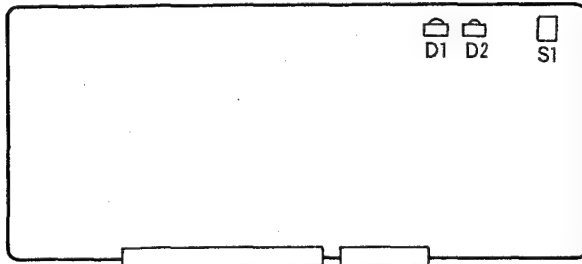

D1: LTC READ indicator (green)

This lights when the longitudinal time code (LTC) is being played back properly.

D2: NON DF indicator (red)

This lights when the DVR-1000 has been set to the non-drop frame mode (when **F5** (DROP F) is set to OFF) on the TC & CHR sub menu.

S1: SET UP switch

All the parameters of the DVR-1000 and DVPC-1000 except those of the control panel are initialized to the statuses applying when the units were shipped by pressing the SYSTEM RESET switch S1/SP-01 or switch the power to on while this SET UP switch is being pressed.

2-10-5. LO-05 Board

A, B, C, D, E, F, G, H, I (soldered jumpers):

Line output impedances

These jumpers select the line output impedance of the TIME CODE, CUE, and MONITOR OUT R/L connectors. For details, refer to section 1-9 "INITIAL SETTING OF SWITCHES AND JUMPERS".

2-10-6. TR-40 Board

A, B, C, D, E, F (soldered jumpers):

Line input impedances

These jumpers select the line input impedance of the TIME CODE and CUE connectors. For details, refer to section 1-9 "INITIAL SETTING OF SWITCHES AND JUMPERS".

2-10-7. IF-138 Board

S1: TIMER/COUNTER RESET switch

This resets the timercounter on the IF-138 board. For details, refer to section 3 "TEST MENU".

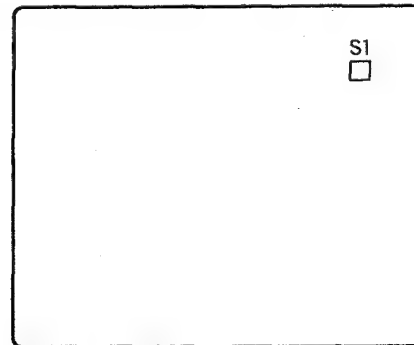

2-10-8. CP-106 Board

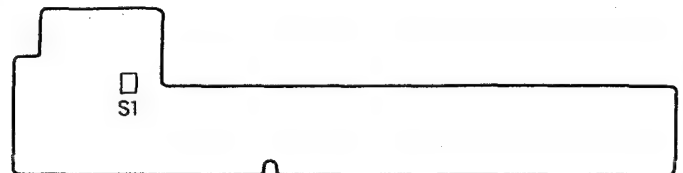

S1: RESET switch

When this switch is pressed, the CPU inside the control panel is reset to the power-on status.



SECTION 3 TEST MENU

3-1. SELECTION OF TEST MENU

If you press **TEST** out of the menu selection keys on the control panel, you will see Test Menu.

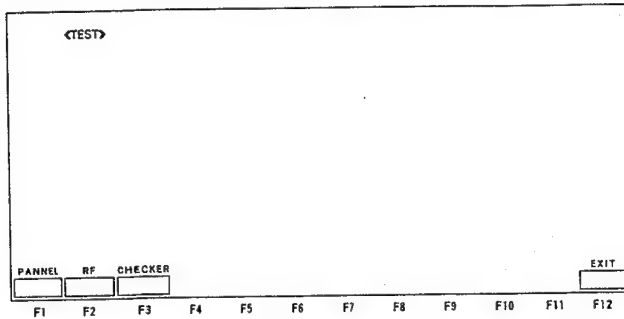

The Test Menu has the following functions.

- F1** (Panel) .. The PANEL menu is displayed when the **F1** key is pressed.
This menu is used for checking the control panel.
- F2** (RF) The RF menu is displayed when the **F2** key is pressed.
This menu is used for adjusting the RF signal system.
- F3** (Checker). The CHECKER menu is displayed when the **F3** key is pressed.
This menu is used for adjusting the SERVO and TAPE TRANSPORT systems.

3-2. PANEL MENU

In the Panel Menu, the following checks will be performed.

For more information, see the DVR-1000 Operation Manual.

- F1** (EL Unit): The display of the control panel will be checked.
- F2** (Input): The keys, switches and dial on the control panel will be checked.
- F3** (Output): LED on the control panel will be checked.

3-3. RF MENU

3-3-1. RF Menu Flowchart

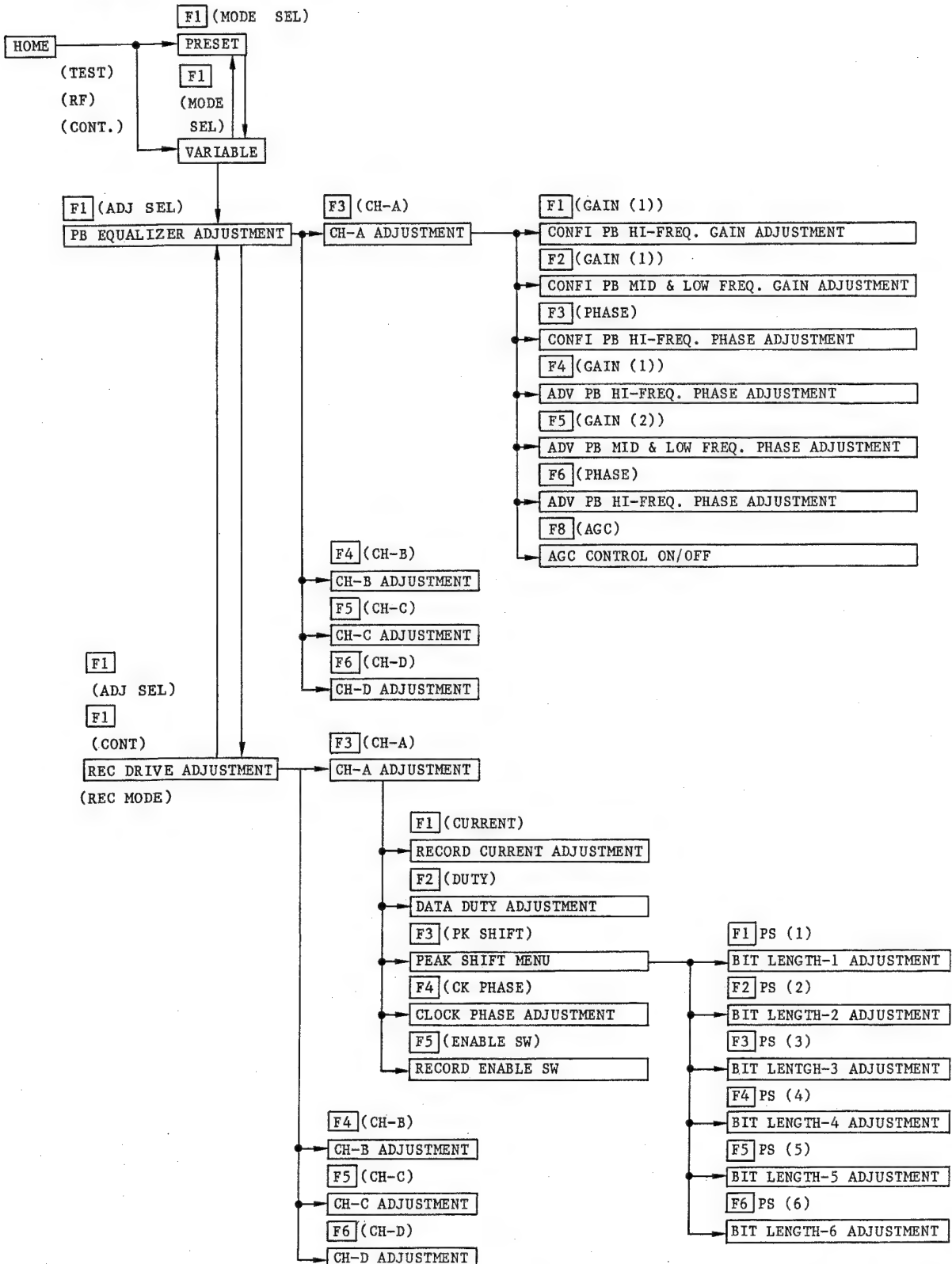

3. TEST MENU

3-3-2. Selection of RF Menu

This menu is used for adjusting the RF signal system.

Note: Perform the adjustment according to this menu with full attention by referring to Section 12. If any improper operation is performed on this menu, the video and audio outputs in good conditions may not be obtained.

Perform the following operations from the control panel.

TEST : Test menu select

F2 (RF) : RF Menu

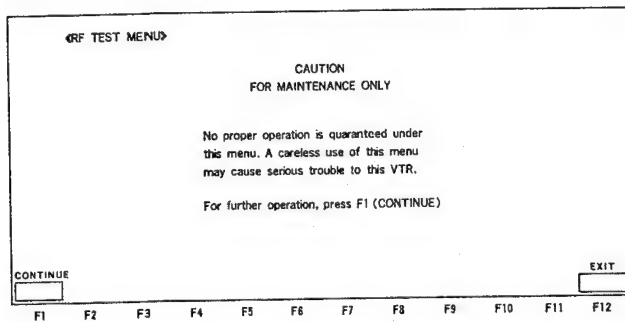

If **F1 (CONTINUE)** key is pressed, the display on the control panel changes to either one of the following.

Press **F12 (EXIT)** key to return to Test Menu.

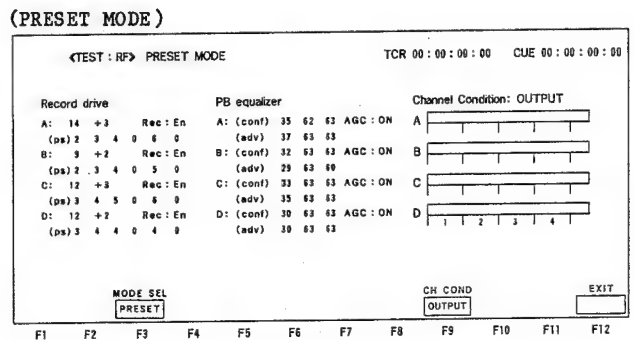
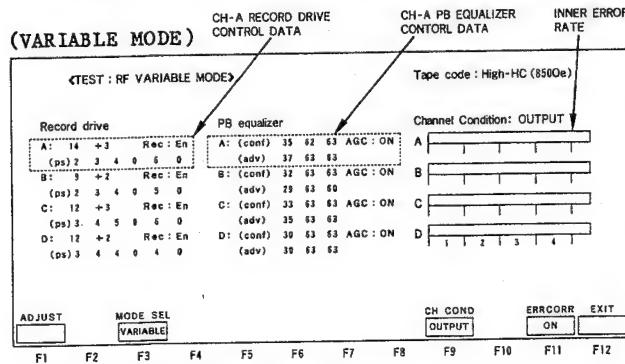

CH-A REC DRIVE CONTROL DATA:

It displays the rec drive control data for each channel.

CH-A PB EQUALIZER CONTROL DATA:

It displays the PB equalizer control data for each channel.

INNER ERROR RATE:

It displays the error rate for each channel.

Channel Condition

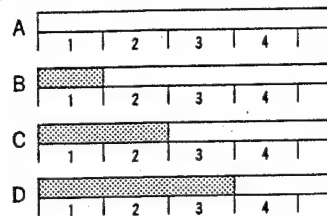

↑ This position corresponds to 1×10^{-7} of the error rate display.



(3-3-2. Selection of RF Menu)

PRESET mode

It shows the data before the adjustment.

- F3** (MODE SEL) : Sets the VARIABLE mode.
- F9** (CH COND) : By pressing this key, the display of the error rate before the correction is made (RAW) or after the correction is made (OUTPUT) can be selected. It does not affect the picture quality and the sound volume.
- F12** (EXIT) : Returns the display to the TEST MENU. Then, all the record enable switches in the REC DRIVE turn "EN."

Note: If the RF menu is terminated during the PRESET mode, all the data adjusted in the VARIABLE mode will be lost. Therefore, if the details of NOVRAM are rewritten with new data, terminate the RF mode after the VARIABLE mode is set. (See 12-4-2 for details.)

VARIABLE mode

This mode is used to adjust the RF control data. The display shows the data after the adjustment.

- F1** (ADJUST) : Sets the PB EQUALIZER adjustment mode.
- F3** (MODE SEL) : Sets the PRESET mode.
- F9** (CH COND) : By pressing this key, the display of the error rate before the correction is made (RAW) or after the correction is made (OUTPUT) can be selected. It does not affect the picture quality and the sound volume.
- F12** (EXIT) : Returns the display to the TEST MENU. Then, all the record enable switches in the REC DRIVE turn "EN."

3-3-3. Selection of the RF Parameter Adjustment Mode

PB EQUALIZER Adjustment mode

- F1** (ADJUST SEL): Sets to REC DRIVE adjustment mode. This key functions only in REC mode.
- F3** ~ **F6** : Selects a channel to be adjusted.
- F9** (CH COND) : Selects a channel to be adjusted.
- F12** (EXIT) : Returns to VARIABLE mode.

REC DRIVE Adjustment Mode

- F1** (ADJUST SEL): Sets to PB EQUALIZER adjustment mode.
- F3** ~ **F6** : Selects a channel to be adjusted.
- F9** (CH COND) : Selects a channel to be adjusted.
- F12** (EXIT) : Returns to VARIABLE mode.

3-3-4. Selection of PB EQUALIZER Adjustment Menu

The display changes to any one of the following if any one of **F3**-**F6** is pressed in the PB EQUALIZER adjustment mode, and the mode changes to the PB EQUALIZER adjustment menu select mode.

F3, **F4**, **F5** and **F6** correspond to CH-A, CH-B, CH-C and CH-D, respectively. See Section 12-4-4 for details of the adjustment method.

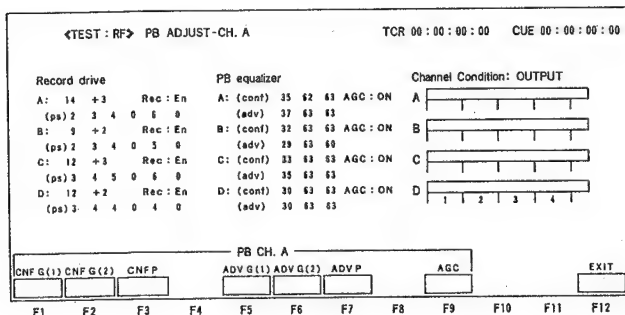

Each display and the data being displayed are as in the following table.

CH-A PB EQUALIZER CONTROL DATA

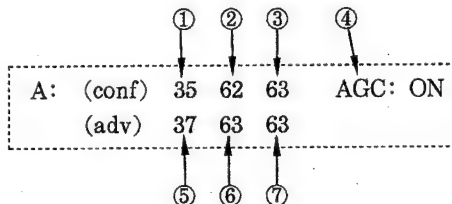

| | FUNCTION KEY | ADJUSTMENT |
|---|----------------------|--|
| ① | F1 (CNF G(1)) | CONFI PB high frequency gain adjustment |
| ② | F2 (CNF G(2)) | CONFI PB mid and low frequency gain adjustment |
| ③ | F3 (CNF P) | CONFI PB high frequency phase adjustment |
| ④ | F9 (AGC) | AGC CONTROL ON/OFF (use it always at "ON.") |
| ⑤ | F5 (ADV G(1)) | ADV PB high frequency gain adjustment |
| ⑥ | F6 (ADV G(2)) | ADV PB mid and low frequency gain adjustment |
| ⑦ | F7 (ADV P) | ADV PB high frequency phase adjustment |
| - | F12 (EXIT) | Returns to the VARIABLE mode. |

3-3-5. Selection of REC DRIVE Adjustment Menu

The display changes to any one of the following if any one of **F3** - **F6** is pressed in the VARIABLE mode, and the mode changes to the REC DRIVE mode.

F3, **F4**, **F5** and **F6** correspond to CH-A, CH-B, CH-C and CH-D, respectively. See Section 12-4-3 for details of the adjustment method.

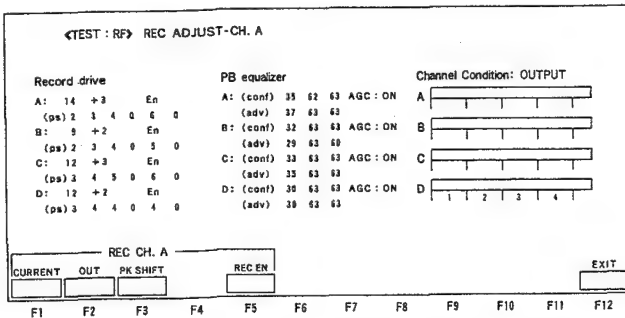

Each display and the data being displayed are as in the following table.

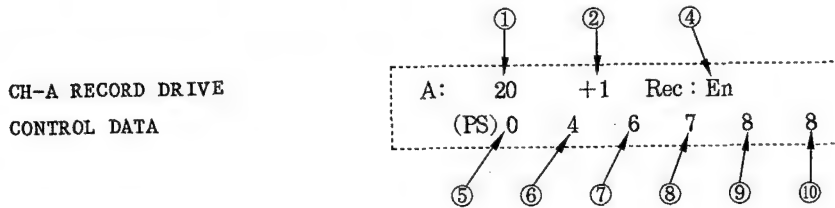

| | FUNCTION KEY | ADJUSTMENT |
|---|----------------------|---------------------------------------|
| ① | F1 (CURRENT) | Recording current adjustment |
| ② | F2 (DUTY) | Recording data duty adjustment |
| - | F3 (PK SHIFT) | PEAK SHIFT MENU |
| ④ | F5 (REC EN) | RECORD ENABLE SW (Always set at "En") |
| - | F12 (EXIT) | Returns to the VARIABLE mode. |

If **F3** (PK SHIFT) key is pressed, the screen changes as follows:

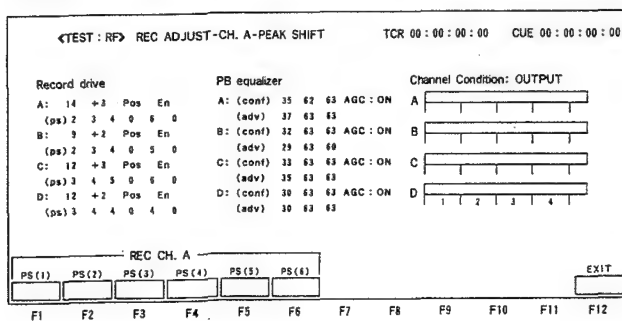

| | FUNCTION KEY | ADJUSTMENT |
|---|-------------------|--------------------------------|
| ⑤ | F1 (1) | Bit length-1 adjustment |
| ⑥ | F2 (2) | Bit length-2 adjustment |
| ⑦ | F3 (3) | Bit length-3 adjustment |
| ⑧ | F4 (4) | Bit length-4 adjustment |
| ⑨ | F5 (5) | Bit length-5 adjustment |
| ⑩ | F6 (6) | Bit length-6 adjustment |
| - | F12 (EXIT) | Returns to the REC DRIVE mode. |

3-3-6. Writing of Control Data

See Section 12-4-5 when it is desired to write the modified data after the adjustment. Press the reset switch S1/SP-01 if it is not desired to write the modified data.

3-4. CHECKER MENU

This menu is used when the servo system or tape transport system is adjusted.

Note: Pay adequate attention to the adjustment using this menu referring to Section 9 and Section 10. If you operate improperly, there may be cases where you cannot get good images and voice.

The following operations are performed from the control panel.

TEST :TEST MENU SELECT

F3 :CHECKER MENU

◀CHECKER TEST MENU▶

CAUTION
FOR MAINTENANCE ONLY

No proper operation is guaranteed under
this menu. A careless use of this menu
may cause serious trouble to this VTR.

For further operation, press F1 (CONTINUE)

CONTINUE
EXIT

F1 F2 F3 F4 F5 F6 F7 F8 F9 F10 F11 F12

When the **F1** (CONTINUE) key is pressed, the CHECKER TEST MENU is displayed on the screen and the cursor appears in the upper left position of the screen. Input the command by referring to Section 3-4-2.

When the **F12** (EXIT) key is pressed, control will return to the TEST MENU.

3-4-1. Explanation of Keys

Function Keys

| Function | Display | Function |
|------------|---------|--|
| F1 | A | Used as "A" for hexadecimal data. |
| F2 | B | Used as "B" for hexadecimal data. |
| F3 | C | "C" for hexadecimal data, Test command (C0-CF) |
| F4 | D | "D" for hexadecimal data, Dump command (D, D\$) |
| F5 | E | "E" for hexadecimal data, Repeat data, Repeat command (E0-EF). |
| F6 | F | "F" for hexadecimal data, Mecha-test command (F0-FF) |
| F7 | \$ | Data set command (\$, \$\$), Memory dump command (D\$) |
| F8 | = | Used as reset command (=0) of VTR. |
| F9 | | Not used. |
| F10 | NVW | Used when writing data on NOVRAM. |
| F11 | VR | Used to display the version of ROM on the SP-01 board. |
| F12 | EXIT | Return to Test Menu. |



(3-4-1. Explanation of Keys)

Cursor Key

In this menu, cursor keys are used as a function key. The function is determined by the combination of three cursor keys including, \leftarrow , \rightarrow and \square . For the explanation in this Section, cursor keys are expressed in f0 through f3.

f0 = \square + \leftarrow , f1 = \leftarrow , f2 = \rightarrow , f3 = \square + \rightarrow

Note: For f0 and f3, you must press the \square key and the \leftarrow key or the \rightarrow key at the same time. However, when some of test commands are executed, each function is determined when you part with the key. Therefore, you must part with the \square key after you have parted with the \leftarrow key or the \rightarrow key.

Other keys:

- SET** ; Used when you key in a command or data.
- /** ; Used as a space key. (Advance to the next address in the case of \$ and \$\$ commands.)
- BS** ; Delete one character before the cursor. (Return back to the previous address in the case of \$ and \$\$ commands.)
- GET** ; Used when data in the same address are read by \$ and \$\$ commands.
- T** ; Used for the real motor test command (T0 to TF).

3-4-2. List of Commands

| Command | Function | Explanation |
|---|--|-------------------|
| F7 (\$) \leftarrow (Address) SET | Memory write: Used when 1 byte data are read and written. | Section 3-4-3 (1) |
| F7 (\$) F7 (\$) \leftarrow (Address) SET | Memory write: Used when 1 word data are read and written. | Section 3-4-3 (1) |
| F4 (D) \leftarrow (Address) SET | Memory dump: Display the content of memory by byte. | Section 3-4-3 (2) |
| F4 (D) F7 (\$) \leftarrow (Address) SET | Memory dump: Display the content of memory by word. | Section 3-4-3 (2) |
| F8 (=) 0 SET | Reset of VIR: The status will be the same as the one when power is switched on or when RESET SW is pressed on the SP-01 board. | Section 3-4-3 (3) |
| F11 (VR) SET | Display of version: Display program versions of two ROMs on the SP-01 board. | Section 3-4-3 (4) |
| F10 (NVW) SET | Write data on NOVRAM. | Section 3-4-3 (5) |
| F10 (NVW) 0 SET | Copy the RF adjustment data in work area to NOVRAM. | Section 3-4-3 (5) |
| "CO" - "CF" | Test mode | Section 3-4-4 |
| "EO" - "EF" | Repeat data check | Section 3-4-5 |
| "FO" - "FF" | Mechanical test mode | Section 3-4-6 |
| "TO" - "TF" | S/T reel test mode | Section 3-4-7 |

3-4-3. Examples of Command Usages

(1) When rewriting memory data; \$ Command, \$\$ Command
Key in data by byte or by word

Example
Data in Address A879 are changed to "00H." As the present data are displayed in the control panel, new data will be keyed in.

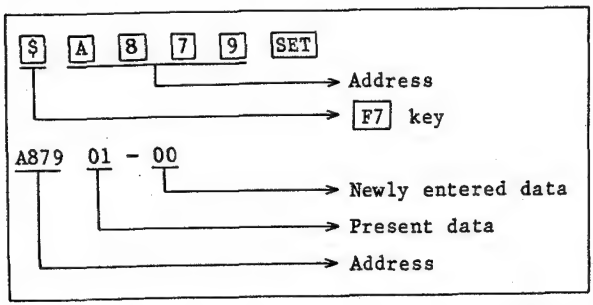

As soon as data input is made, the cursor will be in a position to wait for data in the next byte. Then, if you want to return to the previous byte, press the **[BS]** key. If you want to advance to the next byte, press the **[/]** key. If you press the **[SET]** key, data writing will be completed, and the status will be waiting for command input.

Move to the previous Move to the next byterbyter Data input is completedr

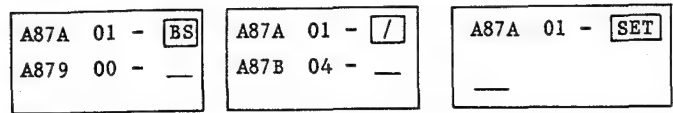

In the above, we have explained the example as to writing data by byte. When you want to rewrite data by word, key in as follows in a state of waiting for command input.

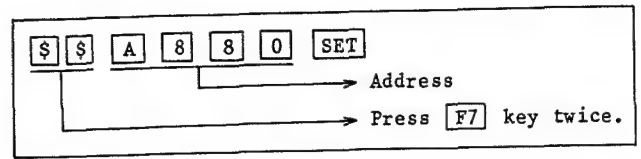

The control panel display will be as follows.

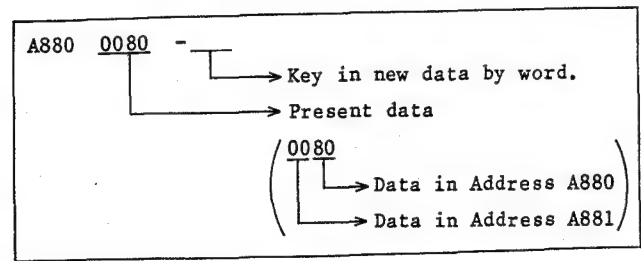

(3-4-3. Examples of Command Usages)

(2) When you want to display the content of memory; D Command, D\$ Command
Display data by byte or by word.

Example

Data are displayed by byte.

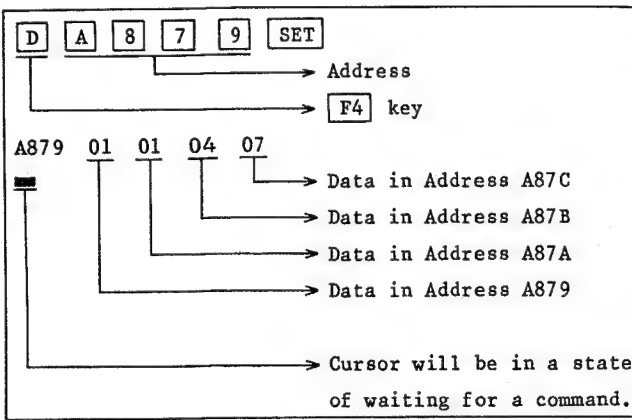

After the D command is executed, if you press the SET key only, data will be displayed starting in the next address.

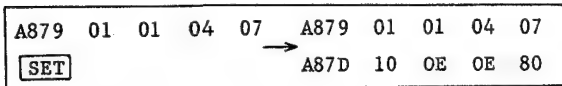

When you want to display data by word, key in as follows.

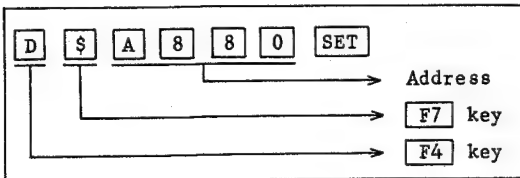

Data will be displayed as follows.

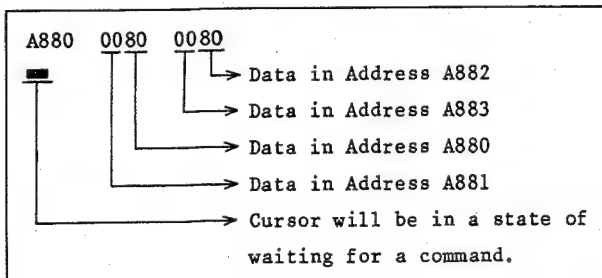

Similar to the D command, when the D\$ command has been executed, data will be displayed starting in the next address, if you press the SET key only.

(3) System Reset: =0 Command

The system will be reset to the same state as the one when power is switched on or SYSTEM RESET SW/SP-01 is pressed.

When this command is executed before data are transferred to NOVDRAM, changed data will be lost by the \$ or \$\$ command.

Example; System reset is made.

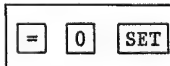

The system will be reset by the key-in given above.

(4) Display of Version: VR Command

Design (program) versions of ROM (ICB12 and B13) on the SP-01 board will be displayed.

Example;

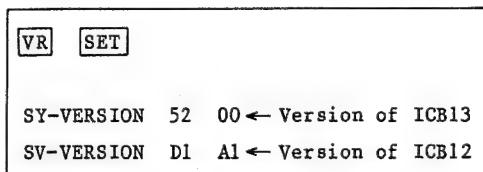

(3-4-3. Examples of Command Usages)

(5) Transfer of Rewritten Data to NOVDRAM:

NVW command, NVW 0 Command

Converted data by \$ command, \$\$ command, etc. will be lost at a time of system reset or power is switched on again if nothing is done. In order to preserve the converted data, you must execute this command.

However, if you rewrite data, the original data will be lost. Therefore, do not change data thoughtlessly.

Use the NVW 0 command when you transfer the adjustment data of the RF signal system to NOVDRAM.

In the case of other data, use the NVW command. Key-in from the control panel is made as follows.

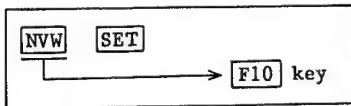

Note: When "BASE SUM ERROR" is displayed in the beginning, it means the failure of NOVDRAM. Confirmation of all data or replacement of NOVDRAM will be required.

Address where data are changed, data before the change and data after the change will be displayed. If the address and data are correct, press the key. If you want to stop writing, press the key. When data in any unplanned address are changed, stop writing.

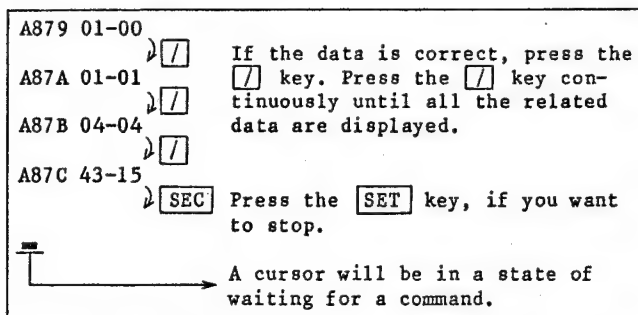

When all the changed data are displayed, "PUSH NVWR SW" will be displayed on the control panel. Then, push NVRW SW S1/SP-01. Data transfer will be started. When the data transfer is completed, "READY" will be displayed, and the NVW command will be terminated. When there are no changed data, "READY" will be displayed and the NVW command will be terminated.

When data of the RF system is transferred, input is made as follows.

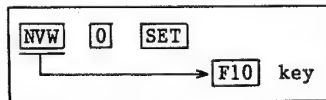

After this, everything is the same as the NVW command.

3-4-4. Test Mode

3. TEST MENU

List of Command

| | COMMAND | FUNCTION |
|---|---------|----------------------------------|
| ① | C0 | TEST MODE OFF |
| ② | C4 | MECHANICAL CHECK MODE |
| ③ | C5 | DAC CHECK & TAPE SPEED MONITOR |
| ④ | C9 | PG ADJUSTMENT |
| ⑤ | CA | CAPSTAN/DRUM V-LOOP ADJUSTMENT |
| ⑥ | CB | REC TAPE SPEED CHECK |
| ⑦ | CC | CAP VELOCITY CONTROL ADJUSTMENT |
| ⑧ | CD | DRUM VELOCITY CONTROL ADJUSTMENT |
| ⑨ | CE | PINCH ADJUSTMENT |
| ⑩ | CF | TRACKING WIDE |

① "C0"; TEST MODE OFF

All test modes will be stopped.

Example

C **0** **SET** ;COMMAND INPUT

E E 3 3 0 0 0 1 0 1 1 B ;DISPLAY DATA NORMAL: 0 ERROR: 1

- CAPSTAN LOCK NORMAL: 0 ERROR: 1
- DRUM LOCK NORMAL: 0 ERROR: 1
- CF LOCK NORMAL: 0 ERROR: 1
- MODE READY NORMAL: 1 ERROR: 0
- SYSTEM ALARM NORMAL: 0 ERROR: 1
- TTP ALARM NORMAL: 0 ERROR: 1
- DRUM ALARM NORMAL: 0 ERROR: 1

→ SERVO MODE
 → SYSTEM CONTROL MODE

- 1: EJECT C: PINCH ON STILL
- 3: STANDBY OFF D: SLOW FWD(VAR)
- 4: STANDBY ON E: SLOW REV(VAR)
- 6: REEL REV(SHUTTLE) F: PLAY(REC)
- 7: REEL FWD(SHUTTLE)

→ LOADING SEQUENCE MODE
 → LOADING SEQUENCE COMMAND

EJECT

- 0: CASSETTE OUT
- 1: EJECT STEP1
- 2: CASSETTE-UP COMPARTMENT UP CONTROL
- 3: UNLOAD END
- 4: UNLOAD
- 5: EJECT STEP5
- 6: EJECT STEP6
- 7: EJECT STEP7

LOADING

- 8: UNLOAD CHECK
- 9: REEL MOTOR MOVING
- A: CASSETTE-UP COMPARTMENT DOWN
- B: TENSION ON
- C: LOADING
- D: LOADING END
- E: LOAD READY WORKING POSITION
- F: PINCH ON MODE

(3-4-4. Test Mode)

② "C4"; MECHANICAL CHECK MODE

Mechanical check mode by "F" command. For more information, see Section 3-4-6.

③ "C5"; DAC CHECK & TAPE SPEED MONITOR

The DA converter on the RS-23 board will be checked.

The following will be outputted to TP6/RS-23 in accordance with the cursor key.

f0([]+[<]); 0V
f1([<]) ; +3.3V
f2([>]) ; LINEARITY
f3([]+[>]); Voltage to suit the tape speed will be outputted.

Example

[C] [5] [SET]; Test mode
f1([<]) ; At this time, output of TP6/RS-23 will be +3.3 Vdc.

④ "C9"; PG ADJUSTMENT

The input polarity of the PG signal will be adjusted so that the effective edge of the PG pulse and the FG pulse on the drum, which is used for input and output counters on the CD-35 board, cannot get close to each other. If this command is continuously made, and the [0] key is pressed, automatic adjustment will be started.

Example

[C] [9] [SET]; Test mode
[0] ; Automatic adjustment is started.

⑤ "CA"; CAPSTAN/DRUM V-LOOP ADJUSTMENT

This command is used when V-LOOP adjustment is made for the capstan and drum with no cassettes. After this command, "CC" or "CD" command will be executed for adjustment.

The capstan/drum will be rotated by the cursor key.

f0([]+[<]), f1([<]); OFF
f2([>]) ; Capstan
f3([]+[>]) ; Drum standby on

Example

[C] [A] [SET]; Test mode
f2([>]) ; Capstan motor will be rotated.

⑥ "CB"; REC TAPE SPEED CHECK

The REC tape speed is checked. If you press the PLAY button, the difference with the standard speed will be displayed in the control panel in hexadecimal numbers with 0000 as the center.

Example

[C] [B] [SET]; Test mode
[PLAY] ; Play mode

1234 004A ABCD Display data
625 mode 74 (4A_H) > 0.1%
525 mode 62 (3E_H) > 0.1%

⑦ "CC"; CAP VELOCITY CONTROL ADJUSTMENT

Free-run speed of capstan V-LOOP will be adjusted. If you key in [A] after this command, automatic adjustment will be started.

*Display in the control panel is the same as the "CB" command.

Example

[C] [C] [SET]; Test mode
[PLAY] ; Play mode (The "CA" command is used when there is no cassette.)
[A] ; Automatic adjustment is performed.

⑧ "CD"; DRUM VELOCITY CONTROL ADJUSTMENT

Free-run speed of drum V-LOOP will be adjusted. If you key in [A] after this command, automatic adjustment will be started. The difference with the standard speed will be displayed in the control panel in hexadecimal numbers.

Example

[C] [D] [SET]; Test mode
[STANDBY] ; Drum standby on (The "CA" command is used when cassette is not used.)
[A] ; Automatic adjustment is performed.

(3-4-4. Test Mode)

⑨ "CE"; PINCH ADJUSTMENT

The FG error check routine is by-passed and the mode will be pinch adjustment mode. This command is used when the tape running system is adjusted.

Example

C E SET ; Test mode

⑩ "CF"; TRACKING WIDE

The control range of the tracking volume will be widened to ± 3.3 msec. The normal range is ± 1.6 msec.

Example

C F SET ; Test mode

3-4-5. Repeat Data Check

These commands will display the data in each work area in hexadecimal numbers or bit images.

List of Commands

| | COMMAND | FUNCTION |
|---|---------|--------------------------------------|
| ① | E0 | DISPLAY OFF |
| ② | E7 | SERVO LOCK TIME MONITOR |
| ③ | E8 | TTP SENSOR MONITOR |
| ④ | E9 | TRACKING CONT MONITOR |
| ⑤ | EA | TENSION/BEGINNING/END SENSOR MONITOR |

① "E0"; DISPLAY OFF

Display of data will be stopped.

Example

E 0 SET ; Command input

② "E7"; SERVO LOCK TIME MONITOR

The servo lock time, stop time and jitter of the drum motor and the capstan motor are displayed in hexadecimal numbers.

Example

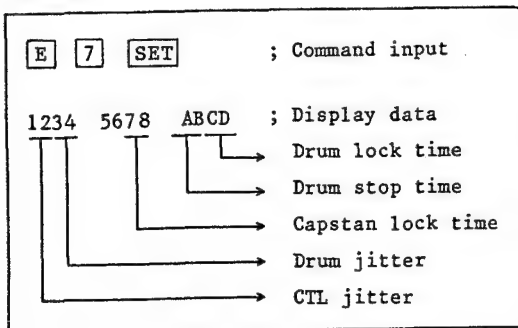

Drum jitter: 1=0.136 usecp-p, CTL jitter: 1=1.085 usecp-p, Other: 1=2V=33.3mS(525)
/40mS(625)

(3-4-5. Repeat Date Check)

③ "E8"; TTP SENSOR MONITOR

The output value of the threading sensor is displayed in hexadecimal numbers, and the status of the cassette up compartment SW is displayed in bit images.

Example

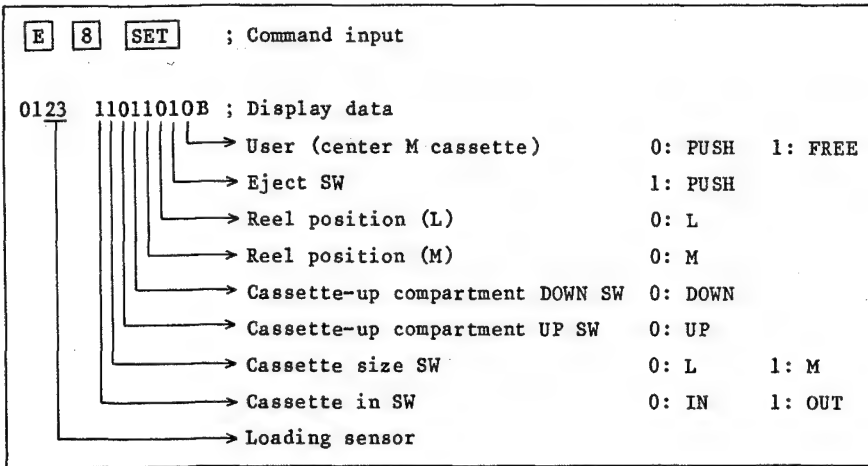

④ "E9"; TRACKING CONT MONITOR

The value of tracking control is displayed in hexadecimal numbers, and the status of the cassette sensor is displayed in bit images.

Example

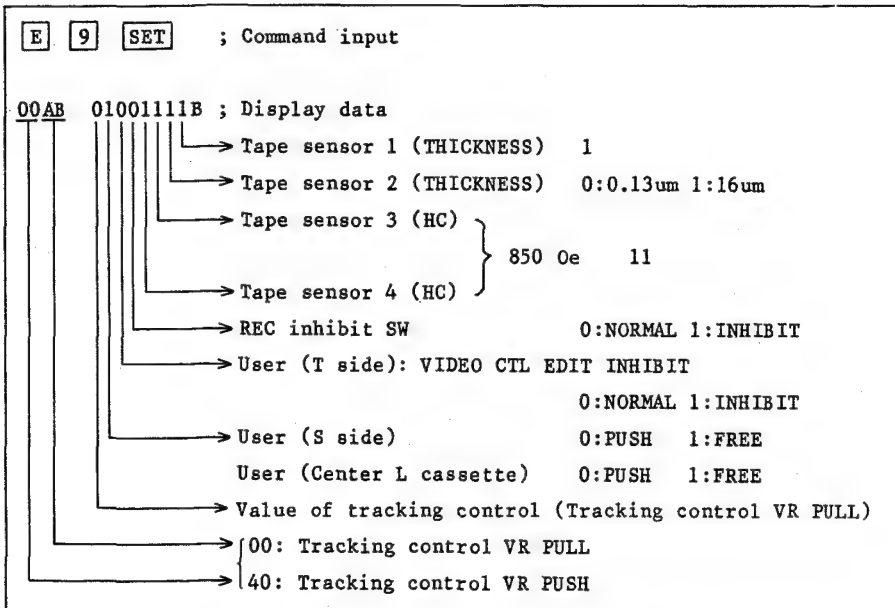

(3-4-5. Repeat Data Check)

⑤ "EA"; TENSION/BEGINNING/END SENSOR MONITOR

The status of the tension sensor and the tape end sensor is displayed in hexadecimal numbers.

Example

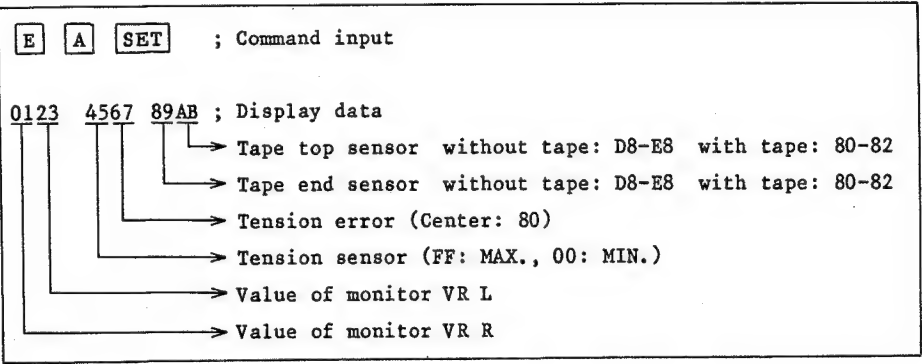

3-4-6. Mechanical Check Mode

The following commands function when the test mode is set to the mechanical check mode by the C4 command.

List of commands

| | Command | Function |
|---|---------|------------------------------|
| ① | F0 | REEL SHIFT TEST |
| ② | F1 | CASSETTE UP COMPARTMENT TEST |
| ③ | F2 | THREADING MOTOR TEST |
| ④ | F3 | PINCH ROLLER TEST |
| ⑤ | F4 | DRUM MOTOR TEST |
| ⑥ | F5 | CAPSTAN MOTOR TEST |
| ⑦ | F6 | S-REEL MOTOR TEST |
| ⑧ | F7 | T-REEL MOTOR TEST |
| ⑨ | F8 | CAPSTAN FG ADJUSTMENT |
| ⑩ | F9 | S-REEL MOTOR FG ADJUSTMENT |
| ⑪ | FA | T-REEL MOTOR FG ADJUSTMENT |
| ⑫ | FF | MANUAL LOADING TEST |

① "F0"; REEL SHIFT TEST

The reel motor is shifted by this command. The reel motor is rotated in the following direction by the cursor keys.

f0(□+<), f1(<): L-cassette direction
 f2(>), f3(□+>): M-cassette direction

Example

```

[F] [0] [SET] ; R-SHIFT
f1 (<) ; The reel motor is shifted to the
          L-cassette position.
0123 01101011B ; Display data
          |
          |-----> Reel position 10:L 01:M
    
```

② "F1"; CASSETTE UP COMPARTMENT TEST

The cassette up compartment is moved by this command. It is moved as follows by the cursor keys.

f0(□+<), f1(<); DOWN
 f2(>), f3(□+>); UP

Example

```

[F] [1] [SET] ; Command input
f1 (<) ; The cassette up compartment moves
          down.
0123 01101000B ; Display data
          |
          |-----> Cassette up compartment position
                    10:DOWN 01:UP
    
```

③ "F2"; THREADING MOTOR TEST

The threading motor is moved by this command. It is moved as follows by the cursor keys.

f0(□+<), f1(<): Threading
 f2(>), f3(□+>): Unthreading

Example

```

[F] [2] [SET] ; Command input
f1 (<) ; The motor is threaded.
0123 01100011B ; Display data
          |
          |-----> Value of threading potentiometer
                    E0:LOAD 1E:UNLOAD
    
```

(3-4-6. Mechanical Check Mode)

④ "F3"; PINCH ROLLER TEST

The pinch roller is turned ON and OFF by this command. It is moved as follows by the cursor keys.

f0(□+◀), f1(◀): OFF

f2(▶): Auto ON and OFF (1.28sec/cycle:625,
1.067sec/cycle:525)

f3(□+▶): The pinch and capstan motors are turned ON.

Example

```

[F] [3] [SET] ; Command input
f2(▶) ; The pinch roller is turned ON
and OFF repeatedly.

0123 01100011B ; Display data
    |
    |-----> One fourth the frequency at
                which the pinch roller is turned
                ON and OFF by f2.
    
```

⑤ "F4"; DRUM MOTOR TEST

The drum motor is rotated. It is moved as follows by the cursor keys.

f0(□+◀), f1(◀): REV (CCW)

f2(▶), f3(□+▶): NORMAL (CW. It is kept
rotating even when
released.)

Example

```

[F] [4] [SET] ; Command input
f2(▶) ; The drum is rotated clockwise.

0123 01100011B ; Display data
    |
    |-----> Direction of drum rotation
                REV(CCW):0 NORMAL(CW):1
    
```

⑥ "F5"; CAPSTAN MOTOR TEST

The capstan motor is rotated. It is moved as follows by the cursor keys.

f0(□+◀), f1(◀): REV (CW)

f2(▶), f3(□+▶): NORMAL (CCW. It is kept
rotating even when
released.)

Example

```

[F] [5] [SET] ; Command input
f1(◀) ; The capstan is rotated
clockwise.

0123 01100011B ; Display data
    |
    |-----> Direction of capstan motor
                rotation
                REV(CW):0 NORMAL(CCW):1
    
```

⑦ "F6"; S-REEL MOTOR TEST

The S-reel motor is rotated. It is moved as follows by the cursor keys.

f0(□+◀), f1(◀): REV (CCW)

f2(▶), f3(□+▶): NORMAL (CW)

Example

```

[F] [6] [SET] ; Command input
f1(▶) ; The reel motor is rotated
counterclockwise.

0123 01100011B ; Display data
    |
    |-----> Direction of reel motor rotation
                REV (CCW):0 NORMAL (CW):1
    
```

⑧ "F7"; T-REEL MOTOR TEST

The T-reel motor is rotated. It is moved as follows by the cursor keys.

f0(□+◀), f1(◀): REV (CCW)

f2(▶), f3(□+▶): NORMAL (CW)

Example

```

[F] [7] [SET] ; Command input
f2(▶) ; The reel motor is rotated
clockwise.

0123 01100011B ; Display data
    |
    |-----> Direction of reel motor rotation
                REV (CCW):0 NORMAL (CW):1
    
```



(3-4-6. Mechanical Check Mode)

- ⑨ "F8"; CAPSTAN FG ADJUSTMENT
- ⑩ "F9"; S-REEL MOTOR FG ADJUSTMENT
- ⑪ "FA"; T-REEL MOTOR FG ADJUSTMENT

The FG of each motor is adjusted. When f3(□+▷) is pressed, the FGs are automatically adjusted. After the completion of adjustment, "READY" appears on the screen.

Example

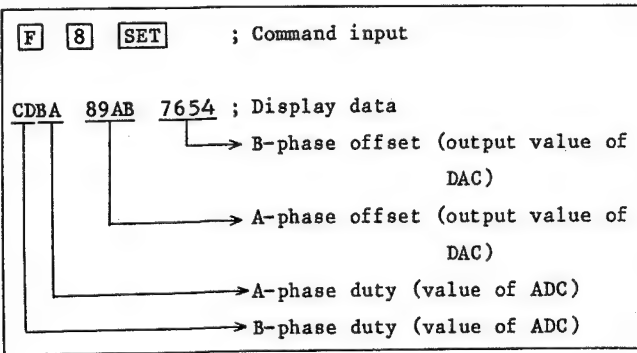

- ⑫ "FF"; MANUAL LOADING TEST

The loading and unloading operations are checked by this command.

f0(□+◀), f1(◀): Loading
 f2(▶), f3(□+▶): Unloading

Example

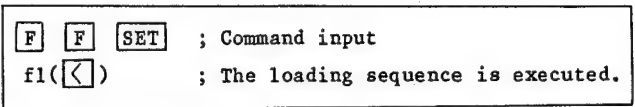

Display data of control panel

At loading

- 20xx 11011101B The reel shift to M position.
 - 30xx 11011101B The cassette up compartment moves down.
 - 40xx 11100101B LOADING
 - 50Ex 11100101B End of loading sequence
- Loading position

At unloading

- 80xx 11100101B UNLOADING
- 81xx 11100101B } End of unloading. Delay of
- 9Fxx 11100101B } tension ON
- A01x 11100101B The cassette up compartment moves up.
- C01x 11100101B The reel shift to L positon.
- F01x 11100101B End of unloading sequence

3-4-7. S/T Reel Test Mode

The T command is used to adjust the reel motor torque.

List of commands

| | Command | Functions |
|---|---------|--|
| ① | T0 | S-REEL TORQUE PRE-ADJUSTMENT (400gcm) |
| ② | T1 | S-REEL TORQUE/TORQUE GAIN |
| ③ | T3 | S-REEL BRAKE CHECK |
| ④ | T8 | T-REEL TORQUE PRE-ADJUSTMENT (400gcm) |
| ⑤ | T9 | T-REEL TORQUE/TORQUE GAIN |
| ⑥ | TB | T-REEL BRAKE CHECK |

The "T0", "T1" and "T3" commands are used for the S-reel adjustment, and the "T8", "T9" and "TB" commands for the T-reel adjustment.

"T0" and "T8"; Initially adjusted to 400g-cm.

"T1" and "T9"; After execution of the "T0" and "T8" commands, the "T1" and "T9" commands are used to change the torque gain and to adjust the torque.

① "T0"; S-REEL TORQUE PRE-ADJUSTMENT (400gcm)

The "T0" command is used to adjust the initial S-reel torque.

Example

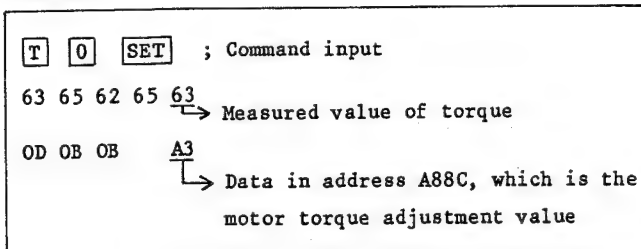

② "T1"; S-REEL TORQUE/TORQUE GAIN

The "T1" command is used to adjust the S-reel torque and torque gain.

Example

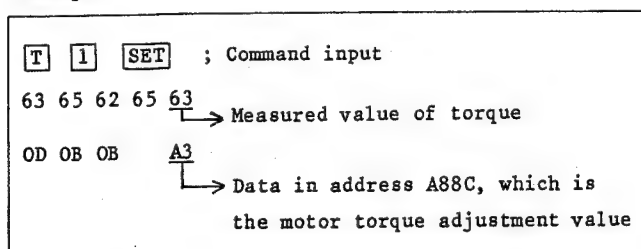

③ "T3"; S-REEL BRAKE CHECK

The "T3" command is used to check the S-reel's brake.

Example

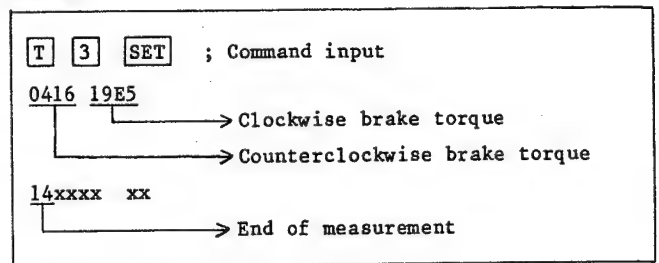

④ "T8"; T-REEL TORQUE PRE-ADJUSTMENT (400gcm)

The "T8" command is used to adjust the initial T-reel torque.

Example

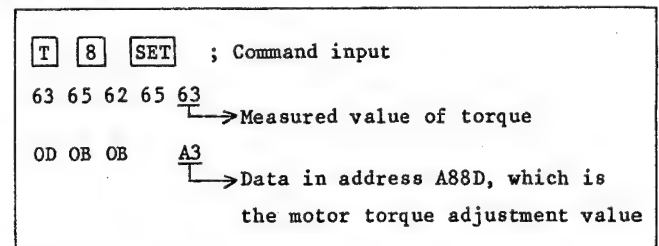

⑤ "T9"; T-REEL TORQUE/TORQUE GAIN

The "T9" command is used to adjust the T-reel's torque and torque gain.

Example

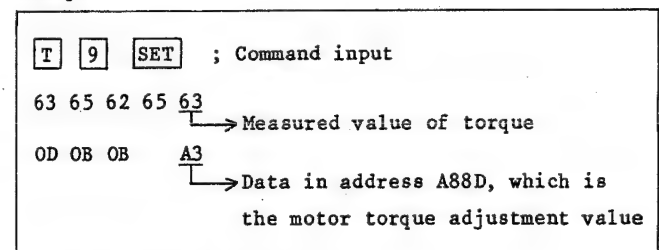

⑥ "TB"; T-REEL BRAKE CHECK

The "TB" command is used to check the T-reel's brake.

Example

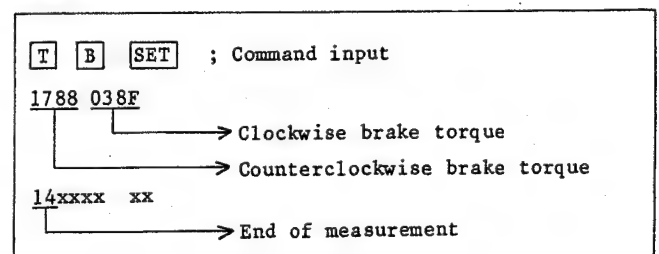

3-5. NOVRAM DATA

The data stored in the NOVRAM and their initial values are shown below. The RF control data are stored in address A800 to address A84F. These data can be changed with the RF menu. The other data are the control data of the servo system and the system controller. These data can be changed with the checker menu. If the mark "x" is in the "Change" column, the data cannot be rewritten.

3. TEST MENU

| Address | Value (HEX.) | Change | Description |
|---------|-----------------|--------|----------------------|
| A800 | } 00 | | ;RF A-ch REC DATA |
| A803 | | | |
| A804 | } 00 | | ;RF A-ch PB DATA |
| A809 | | | |
| A80A | } 00 | | ;RF B-ch REC DATA |
| A80D | | | |
| A80E | } 00 | | ;RF B-ch PB DATA |
| A813 | | | |
| A814 | } 00 | | ;RF C-ch REC DATA |
| A817 | | | |
| A818 | } 00 | | ;RF C-ch PB DATA |
| A81D | | | |
| A81E | } 00 | | ;RF D-ch REC DATA |
| A821 | | | |
| A822 | } 00 | | ;RF D-ch PB DATA |
| A827 | | | |
| A828 | } 00 | X | ;RF DATA (RESERVED) |
| A84F | | | |
| A850 | } 00 | X | } RESERVED |
| A853 | | | |
| A854 | 05 | X | |
| A855 | } 00 | X | ;Not used |
| A86F | | | |
| A870 | 08 | X | ;TEST MODE 08:NORMAL |

(3-5. NOVRAM DATA)

| Address | Value (HEX.) | Change | Description |
|---------|-----------------|--------|--|
| A871 | 31 | X | } RESERVED |
| A872 | 00 | X | |
| A873 | 43 | X | |
| A874 | 00 | X | |
| A875 | 00 | X | |
| A876 | 14 | X | |
| A877 | 83 | X | |
| A878 | 02 | X | |
| A879 | 01 | | ;GPIB mode 01:DVR+DVPC 00:DVR |
| A87A | 01 | X | } RESERVED |
| A87B | 04 | X | |
| A87C | 07 | X | |
| A87D | 10 | X | |
| A87E | 0E | X | |
| A87F | 0E | | 525/625 in DVR single mode 0E:625 06:525 |
| A880 | 8000 | | Capstan FG A-phase DUTY adjustment data |
| A882 | 8000 | | Capstan FG B-phase DUTY adjustment data |
| A884 | 8000 | | S-reel FG A-phase DUTY adjustment data |
| A886 | 8000 | | S-reel FG B-phase DUTY adjustment data |
| A888 | 8000 | | T-reel FG A-phase DUTY adjustment data |
| A88A | 8000 | | T-reel FG B-phase DUTY adjustment data |
| A88C | 80 | | Capstan FG A-phase level data |
| A88D | 80 | | Capstan FG B-phase level data |
| A88E | 80 | | S-reel motor torque adjustment data |
| A88F | 80 | | T-reel motor torque adjustment data |
| A890 | 8000 | | Tension sensor offset adjustment data |
| A892 | 40 | | Tension sensor gain adjustment data |
| A893 | 0000 | | S-reel motor drive offset data |
| A895 | 0000 | | T-reel motor drive offset data |
| A897 | } 00 | X | Not used |
| A89F | | | |
| A8A0 | 20 | | Unloading position data |
| A8A1 | E0 | X | Loading position data |

(3-5. NOV RAM DATA)

| Address | Value (HEX.) | Change | Description |
|---------|-----------------|--------|---|
| A8A2 | 10 | X | RESERVED |
| A8A3 | } | X | |
| A8A5 | | 00 | |
| A8A6 | | 32 | |
| A8A7 | 48 | X | Cassette up compartment's motor current feedback gain |
| A8A8 | 04 | X | Loading motor feedback gain |
| | | | Loading system flag |
| | | | D7-4: SPARE |
| | | | D3: TAPE END/TOP RELOAD 1:OFF 0:ON(RELOAD AT END/TOP DET) |
| | | | D2: CASSETTE INSW POLARITY 1:NORMAL |
| | | | D1: CASSECOM AUTO EJECT 1:OFF 0:ON AT INSW OUT |
| | | | D0: SPARE |
| A8A9 | } | X | Not used |
| A8AF | | | |
| A8B0 | 20 | X | Tension servo DC gain |
| A8B1 | 28 | X | Tension servo AC gain (PLAY) |
| A8B2 | 14 | X | Tension servo AC gain (STUNT) |
| A8B3 | 0A | X | Tension servo AC gain (STOP) |
| A8B4 | 00 | X | PLAY MODE tension adjustment |
| A8B5 | } | X | Not used |
| A8B9 | | | |
| A8BA | 00 | | S-reel's counterclockwise friction data |
| A8BB | 00 | | S-reel's clockwise friction data |
| A8BC | 00 | | T-reel's counterclockwise friction data |
| A8BD | 00 | | T-reel's clockwise friction data |
| A8BE | 3000 | X | Reel delivery torque limit |
| A8C0 | 00 | | Recording tape speed adjustment 01:0.0125% (e.g. 10H:-0.2%, FOH:+0.2%) |
| A8C1 | 00 | X | Frame lock preset |
| A8C2 | 5141 | | Capstan free run speed adjustment data |
| A8C4 | } | X | Not used |
| A8C7 | | | |
| A8C8 | 0000 | X | RESERVED |
| A8CA | 0014 | X | PB CTL-phase offset |
| A8CC | } | X | RESERVED |
| A8CF | | | |

(3-5. NOVRAM DATA)

| Address | Value (HEX.) | Change | Description |
|---------|-----------------|--------|---|
| A8D0 | 38 | | Drum PG-phase rough adjustment data 02H: approx. 140 μ S |
| A8D1 | 0200 | | Drum PG-phase fine adjustment data 10H: 2.17 μ S |
| A8D3 | 0000 | X | RESERVED |
| A8D5 | 00 | X | Not used |
| A8D6 | 0F80 | | Drum motor free run speed adjustment data |
| A8D8 | 0080 | X | PG offset in 625 mode |
| A8DA | 00 | X | RESERVED |
| A8DB | 00 | X | Not used |
| A8DF | | | |
| A8E0 | 00 | X | RESERVED |
| A8E4 | | | |
| A8E5 | 00 | X | Not used |
| A8FD | | | |
| A8FE | XXXX | | NOVRAM check sum data |

3-6. METHOD FOR INDIVIDUAL RESETTING OF
OPERATION TIME

Step 1.

Remove the bottom slot cover of the IF slot on the rear side.

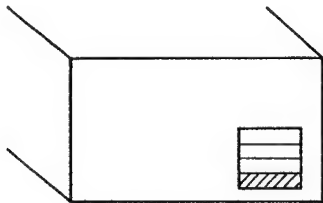

Step 2.

Perform the following operations from the control panel.

TEST, **CHECKER**, **CONTINUE**, **T RESET**

Step 3.

Press the timer key to reset. (The corresponding indicator blinks.)

DRUM or **TAPE** or **THREAD**

Step 4.

While holding down the pushbutton switch S1, which is located inside the slot cover, press **SET** on the control panel.

(The corresponding timer is reset.)

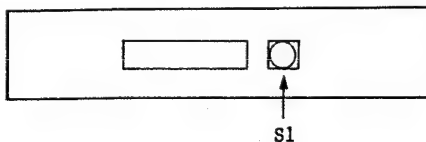

Step 5.

Return the slot cover to its original position.
(Completed)

Note: Operation Time cannot be reset.

SECTION 4

THEORY OF OPERATION

4-1. OUTLINE

The Sony 4:2:2 component digital VTR system conforms to the world-wide standard CCIR-657. It can digitally play back and record both video and audio signals, ensuring high picture quality and sound quality. Also, by inter-connecting the units of the system using digital signals alone, dubbing and editing can be performed without degradation of picture or sound quality.

This system consists of three units.

BKDV-1010: Control Panel

This is a full graphic control panel which uses a 640 x 200 dot EL display. Almost all system operations are performed from this panel. This unit is a standard component of the DVR-1000. It is connected to the DVR-1000 proper by a single dedicated cable. The unit can also be controlled remotely (from a distance of up to 1 Km) by using it in combination with the optional remote control adapter.

DVR-1000: Digital Cassette VTR

This VTR controls the tapetransport system during recording and playback.

DVPC-1000: Digital Signal Processor

This unit digitally processes the video and audio analog/digital signals. The DVR-1000 and DVPV-1000 are connected to each other by 25-pin and 50-pin multi-connector cables (two cables).

The main features of this system are as follows.

World-wide Standard System

The system can be used with either the 525/60 or 625/50 scanning line system. The required selection is made by operating the system select switch in the DVPC-1000.

The supply line voltage selector can be set to either 100 to 120 V or 220 to 240 V.

Powerful Error Correction Performance

The power error correction performance of the D-1 format (OUTER/INNER ERROR CORRECTION CODE 2-dimensional product code) permits high quality reproduction even if data read errors occur due to dirt or scratches on the tape. Also, when error correction cannot be done, the error compensation circuit compensates for the missing signal.

Menu Operation

In this system, various settings related to recording, playback and editing are made using a menu, enabling settings that were done with switches and potentiometers on previous VTRs to be done from the keyboard on the control panel. The system also has such functions as multi-cue and full graphic edit which could not be provided independently on previous VTRs.

Provided With Various Input and Output Interfaces

This system has various input and output terminals for both video and audio signals, enabling both digital and analog signals to be input and output. It also has a 12-pin multi-connector, enabling the analog component signal of the Betacam to be input or output directly.

An RS-422 interface is provided as standard, enabling almost all VTR settings to be made using external equipment. RS232C and PARALLEL I/O interfaces are available as options.

Analog Cue Channel

The system has a single channel analog cue track in the longitudinal direction in addition to four channels of digital audio. On this track, the MIC/LINE input signal or a digital mixed signal produced by mixing the audio signals input to the digital audio channels can be recorded, which is useful when searching for the editing point.

Cassette Tape

This system can accept both M size and L size D1 standard cassette tapes of both 16 μm and 13 μm thickness. The recording time for an L size cassette (tape thickness 13 μm) is about 94 minutes. The size of the cassette tape used is sensed automatically, and the cassette loaded correctly by the reel motor shift mechanism.

Dedicated Recording and Playback Heads

The system has four recording and four playback heads, enabling the playback signals to be monitored while recording is taking place, and the tape and recording condition to be checked. It also has four audio advance playback heads, permitting editing between audio channels and also independent editing of the audio, without any time delay.

4-1-1. Tape Pattern

Fig. 1-1-1. shows the tape pattern for the D-1 format. This is same for both the 525/60 and 625/50 formats. Also, the dimensions are the same apart from the indicated dimensions. The tape pattern for the D-1 format consists of three longitu-

dinal tracks, namely cue audio, time code, and control tracks, and also slant tracks containing digital video and audio data, called program tracks. Each program track consists of two video sectors and four audio sectors. Details of these are given in the theory of operation of the DVPC-1000. Also, details of the longitudinal tracks are given in 4-1-4..

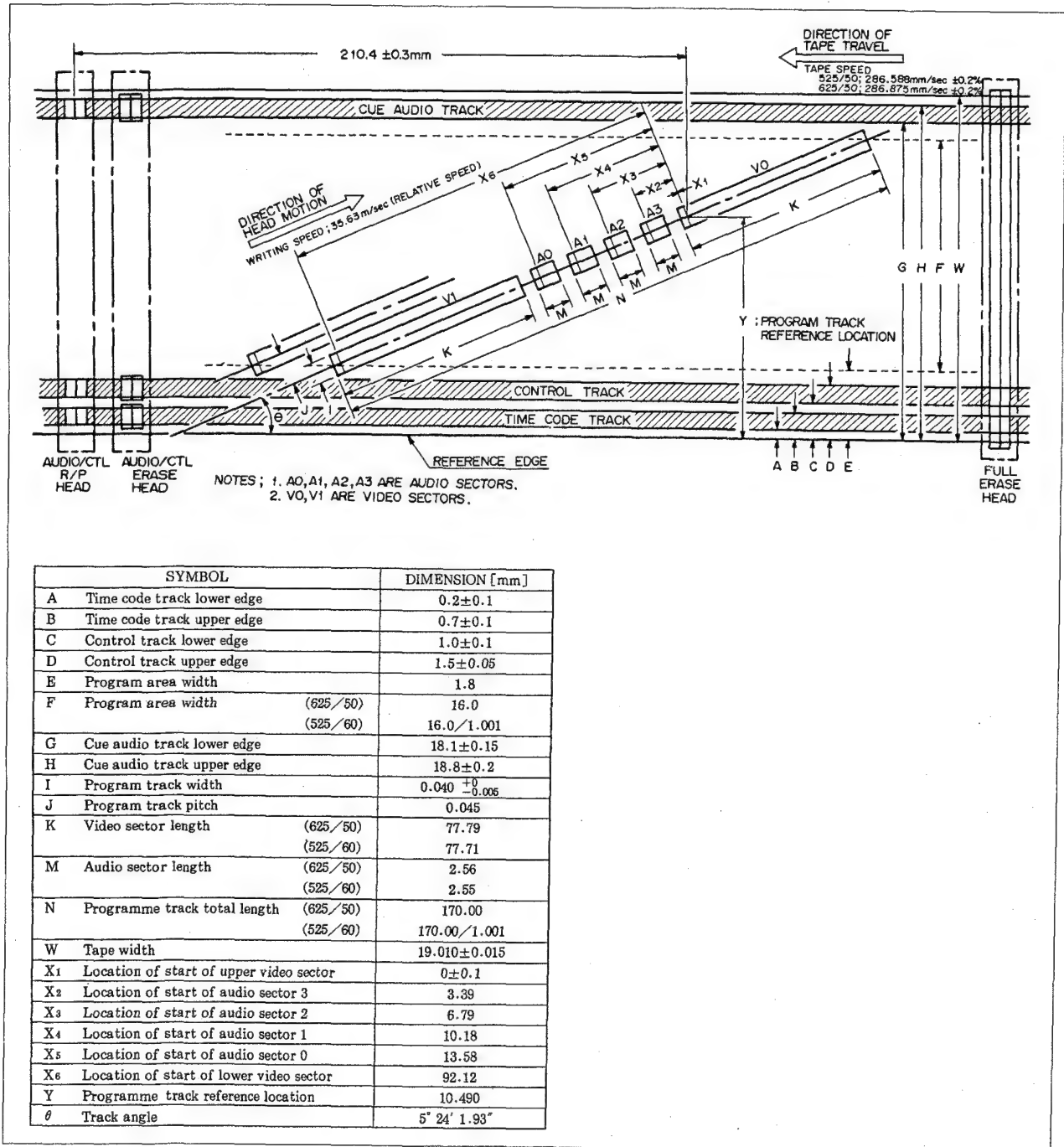

Fig. 1-1-1. Tape Pattern

4-1-2. Cassette Tape

As mentioned previously, the DVR-1000 can accept both M and L size D-1 standard cassette tapes of both 13 μm and 16 μm thickness. The size of the cassette used is sensed by the cassette size sensor in the DVR-1000, ensuring that cassettes of both sizes are loaded correctly.

D-1 standard cassettes have the four holes called coding holes, and also four holes called userholes. These are shown in Fig. 1-2-1..

The coding holes are used by the cassette maker to indicate data concerning the tape thickness and also the coercivity of the tape. The user holes indicate the way in which the tape is used. They have plugs enabling them to be reset. These holes are shown in Fig. 1-2-2. and Fig. 1-2-3..

The set condition of the coding holes and user holes is sensed by the respective sensors in the DVR-1000, and the system set by the data read from the sensors. See section 4-4-5. for details of the layout and function of each sensor in the DVR-1000.

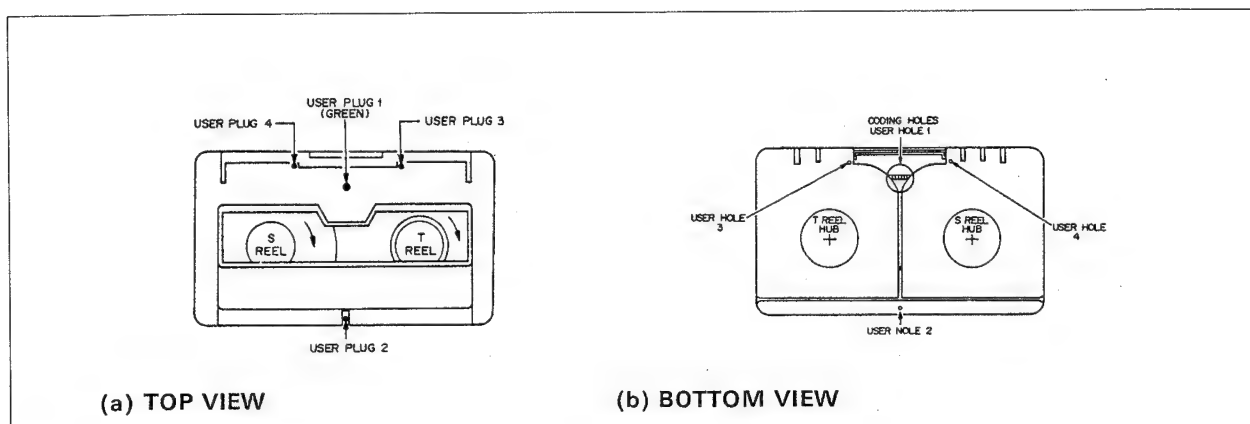

Fig. 1-2-1. Cassette Tape

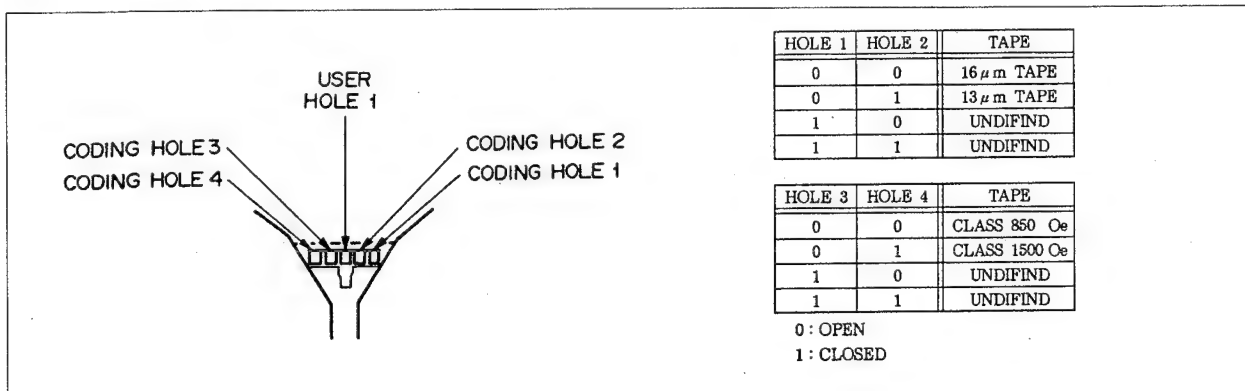

Fig. 1-2-2. Coding Holes

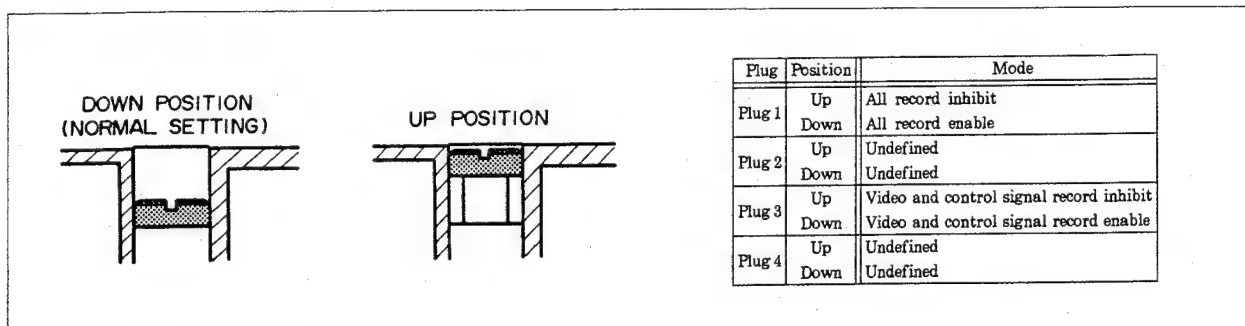

Fig. 1-2-3. User Holes/Plugs

4-1-3. Tape Transport

Fig. 1-3-1. shows the location of each guide in the tape transport.

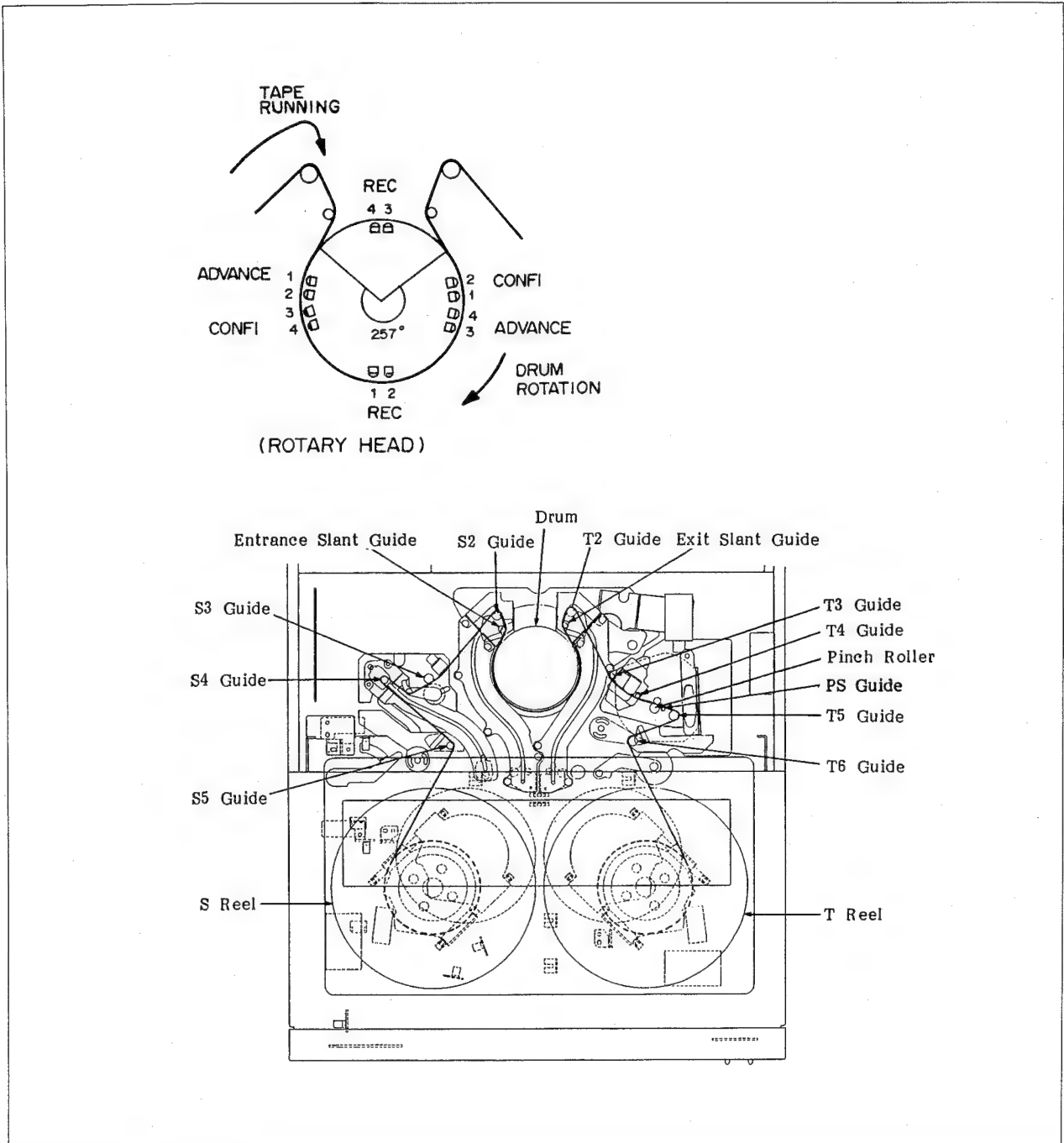

Fig. 1-3-1. Tape Transport

4-1-4. Longitudinal Track

As shown in Fig. 1-1-1., cue audio, time code, and control tracks are provided in the D-1 format. These tracks are described below.

1. Control Track

As shown in Fig. 1-4-1., on the control track is recorded a series of pulse doublets (double pulses).

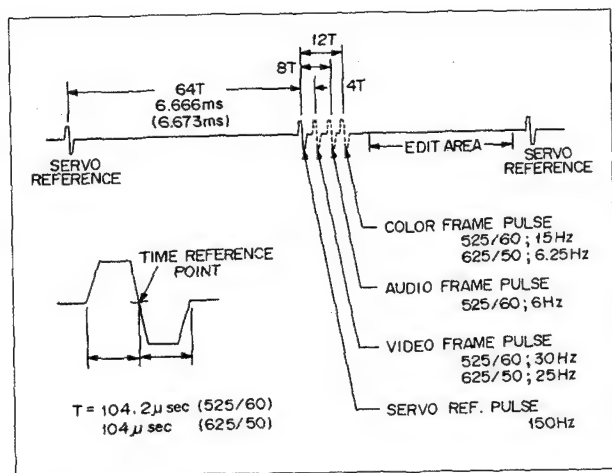

Fig. 1-4-1. CTL Pulses

(A) Servo reference pulse

When recording is taking place, the servo reference pulse is aligned with video sector 0, as shown in Fig. 1-4-2..

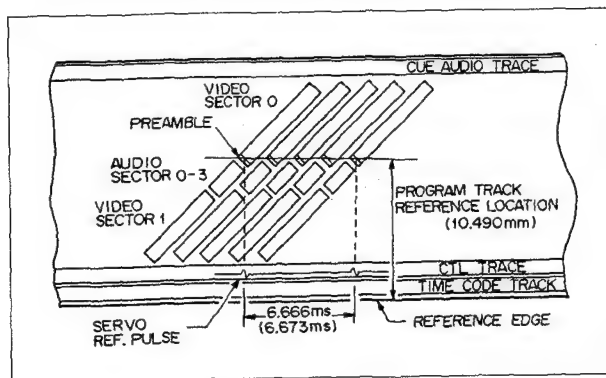

Fig. 1-4-2. Servo Reference Pulses

(B) Video frame pulse

This pulse define the first segment of the video frame.

(C) Audio frame pulse

In the 525/60 system, the audio frame pulse designate the start of the audio frame sequence.

(D) Color frame pulse

The color frame pulse designate the start of color framing.

2. Cue Audio Track

On this track is recorded the MIC/LINE connector input signal or a digital mixed signal produced by selecting and mixing arbitrary signals from the audio signals input to the digital audio channels.

3. Time Code Track

The time code data is recorded using an AC bias method. The time code data recorded on the tape is bi-phase mark-coding. The recorded time code signals are the same SMPTE/EBU time codes as those used in 1-inch type-C VTRs, enabling the unit to be connected to existing machines.

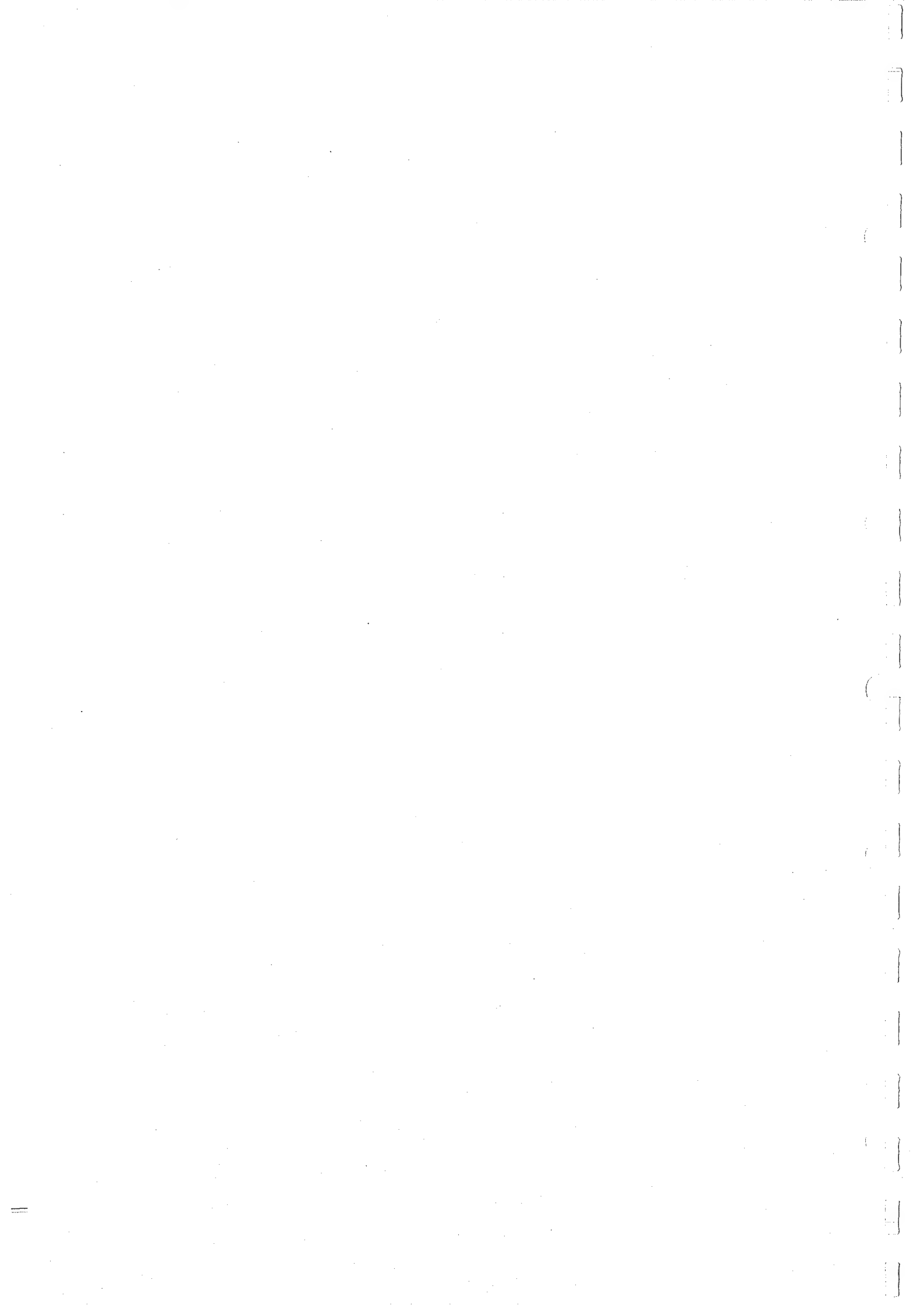

4-2. AUDIO SIGNAL SYSTEM (CUE/TC/CTL)

4-2-1. Outline

The audio signal system performs recording/playback and erasure of the CUE, CTL and TC (time code) channels recorded in the longitudinal tracks. The control signals for this signal system are sent from the SP-01 board as serial data. Fig. 2-1-1. shows the block diagram of the audio signal system. The main functions of each board are as follows.

(A) AE-05 board

This board consists of the recording amplifier, playback amplifier and erase amplifier for each of the CUE, CTL and TC channels, and also the CUE and TC bias amplifiers and the TC-CTL crosstalk cancel amplifier.

(B) TR-40 board

This board consists of the audio monitor amplifier, audio input transformer, input impedance selector and the WFM (Waveform Monitor) output select circuit.

(C) LO-05 board

This board consists of a drive amplifier which outputs the

CUE, TC and AUDIO MONITOR L/R signals to output, and also peripheral circuits.

(D) VR-50 board

This board consists of a headphone jack and monitor level control circuit.

The digital mixed signal D-MIX supplied from the DVPC-1000, or the MIC input signal or LINE input signal input via the CUE IN connector on the connector panel, is selected and recorded on the CUE channel.

The TC LINE IN signal supplied from outside via the TIME CODE IN connector or the time code data generated in the SY-69 board is selected and recorded in the TC channel. The CTL signal generated in the CD-35 board is recorded in the CTL channel.

The audio signal selected by the DVPC-1000 or the CUE playback signal is selected and sent to the audio monitor output.

A detailed description of each circuit in the audio signal system is given below. This description concerns boards whose board numbers are suffixed with "-11".

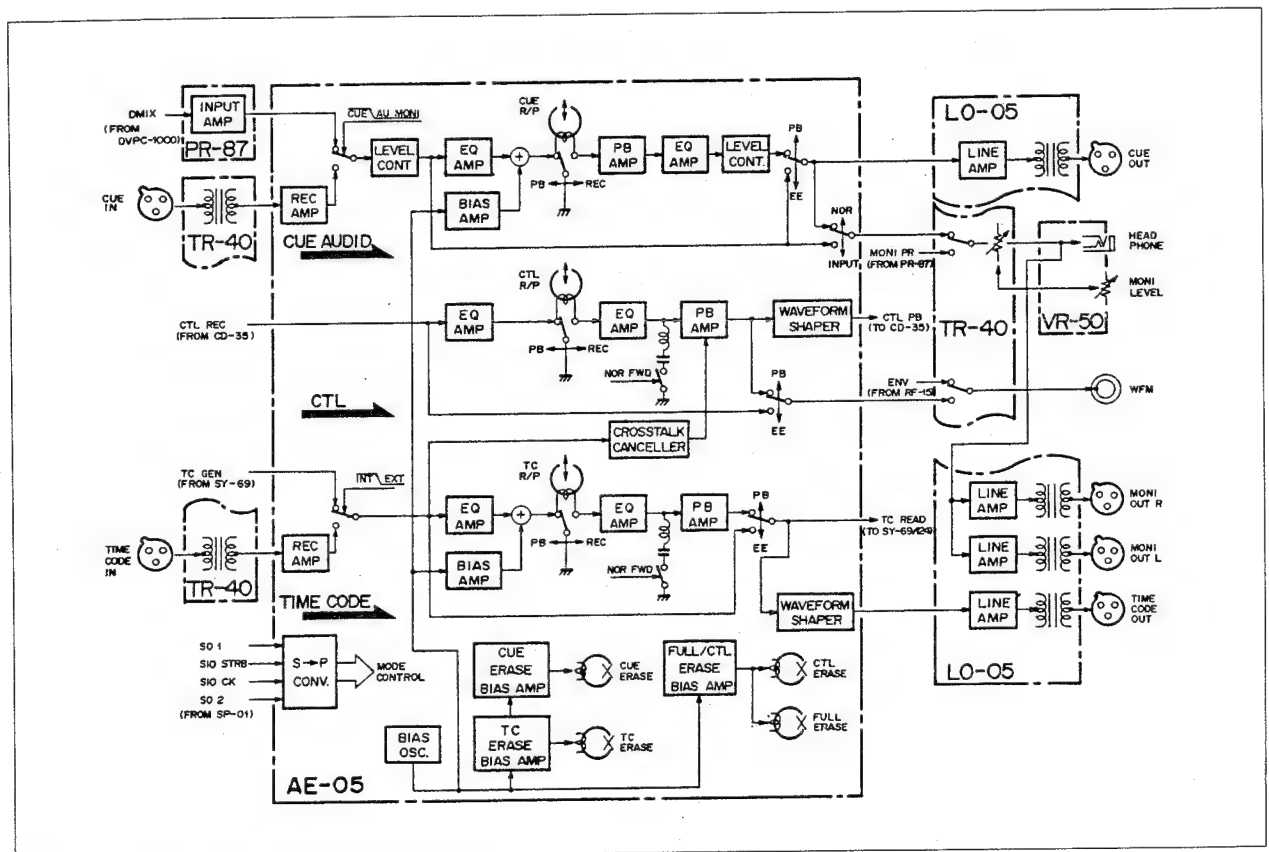

Fig. 2-1-1. Audio Signal System Block Diagram

4-2-2. Serial Interface (AE-05/TR-40 Board)

The audio signal system is controlled by serial data sent from the SP-01 board. The AE-05 board and TR-40 board convert this signal into 8-bit parallel data, and control each circuit in the board.

1. TR-40 Board

The serial data sent from the SP-01 board is converted into parallel data by IC10.

2. AE-05 Board

The serial data from the SP-01 board is converted into parallel data by IC401, 402, 403 and IC410. Also, the data which indicates the condition of the board is converted into serial data by IC409, and output to the SP-01 board.

4-2-3. Line Input Transformer (TR-40 Board)

Each signal which is input to the CUE IN connector and TC IN connector on the connector panel is input to the TR-40 board, then sent to the AE-05 board via transformers T1 and T2.

The line input impedance of both transformers can be switched between 10 K Ω and 600 Ω by means of a slide switch at the side of the connector. When the switch is in the 600 position and the soldered jumpers (A) (CTL) and (B) (TC) on the TR-40 board are shorted, the input impedance will become 150 Ω . In addition, the transformers can be matched to various input impedances by connecting arbitrary resistors between (E)—(F) (CTL) or (C)—(D) (TC).

The CUE IN connector also functions as the LINE input/MIC input, hence when the MIC input is selected it is necessary to make the input impedance 10 K Ω regardless of the setting of the slide switch at the side of the connector. Consequently, the control signal (H; MIC) sent from the SP-01 board drives relay RY1, causing the input impedance to change over.

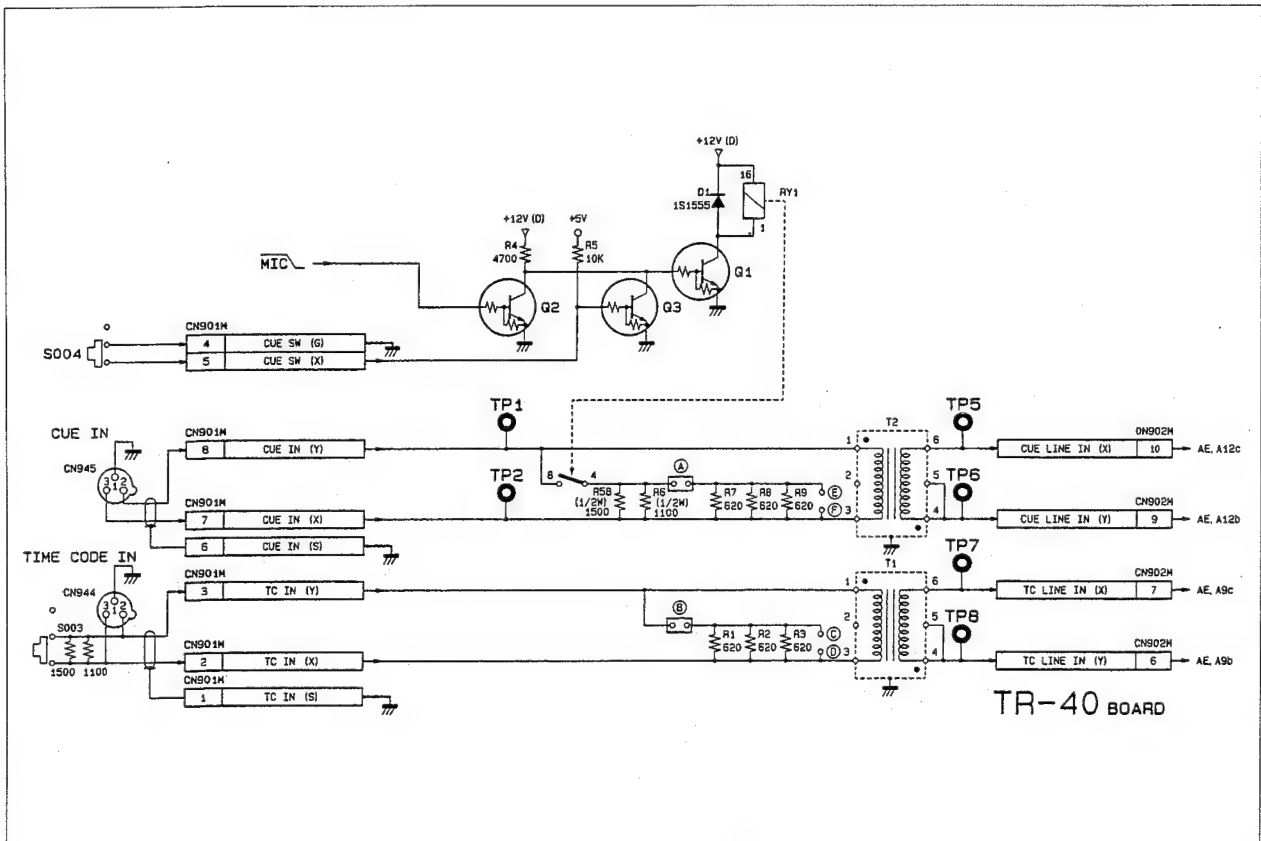

Fig. 2-3-1. Input Transformer/Input Impedance Selector (TR-40 Board)

4-2-4. CUE Recording/Playback Circuit (AE-05 Board)

1. CUE Recording Amplifier (AE-05 Board)

The CUE signal which is output from the input transformer on the TR-40 board enters the AE-05 board, and is then amplified by differential amplifier IC101. The gain of IC101 is -13dB when the LINE input is selected, and +50dB when the MIC input is selected. The selection between LINE and MIC input is made from the control panel. In this circuit the gain of the amplifier is switched according to the status of the CUE INPUT SEL1 signal supplied from the SP-01 board.

Either the CUE INPUT signal or the AU MONI L+R signal supplied from the DVPC-1000 is selected according to the status of the CUE INPUT SEL2 signal, then supplied to the level control circuit in the next stage.

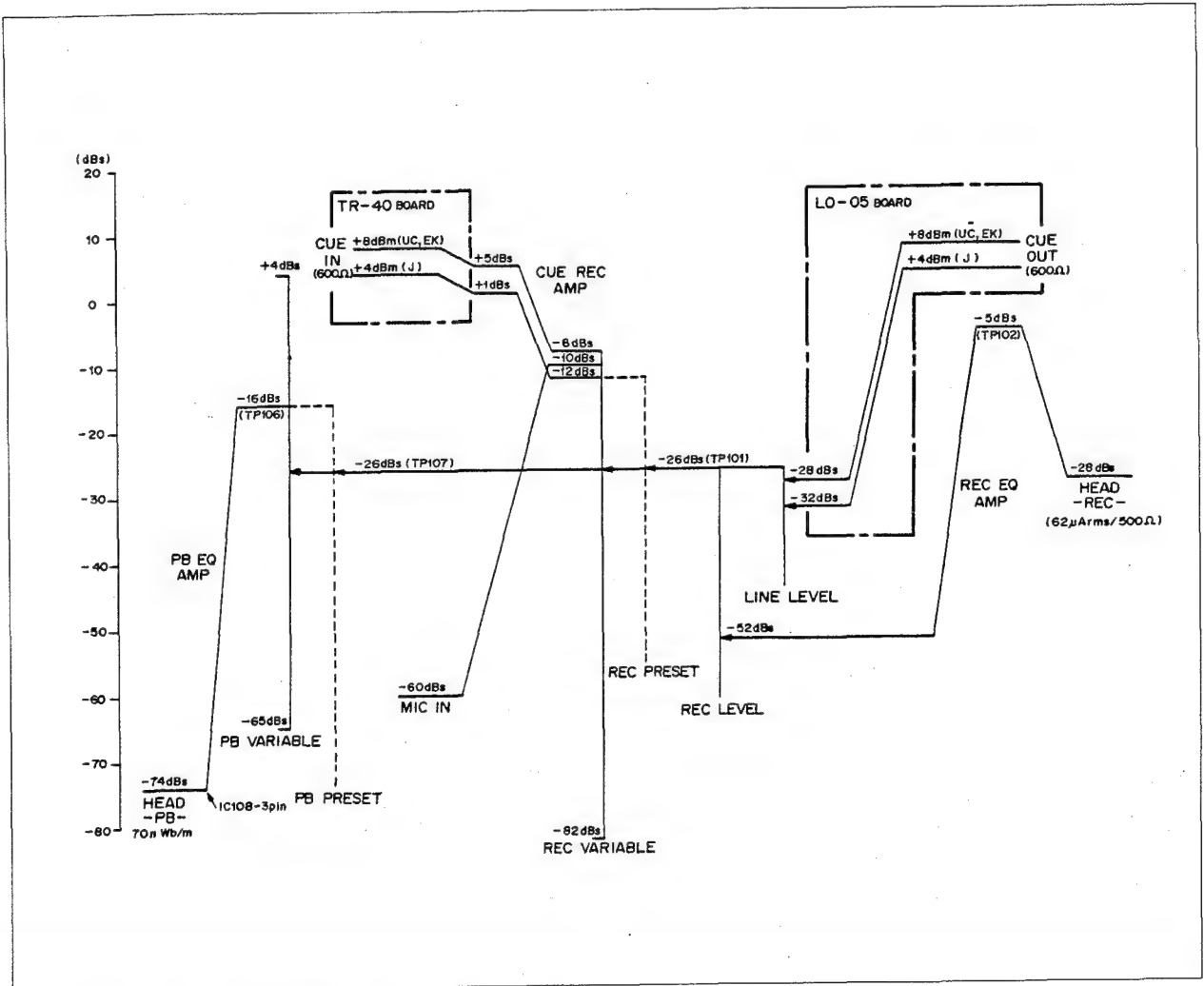

Fig. 2-4-1. Level Chart (CUE Channel)

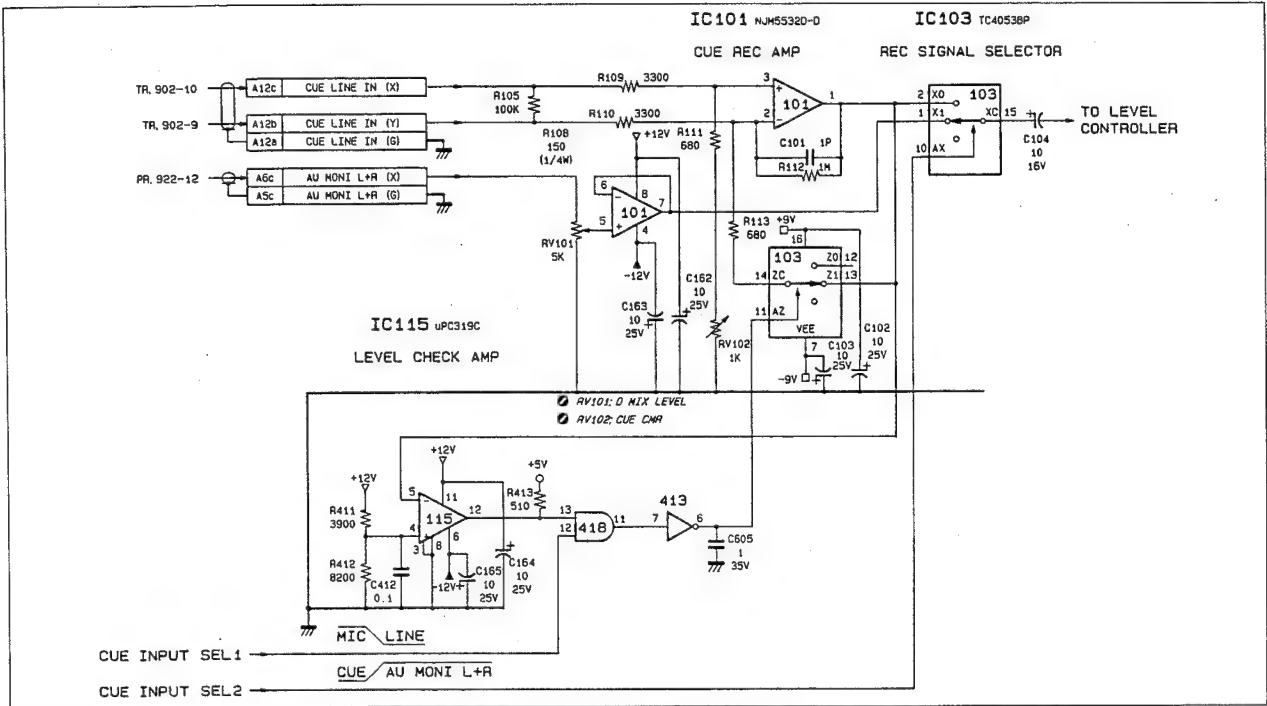

Fig. 2-4-2. CUE Recording Amplifier/Input Level Check Circuit (AE-05 Board)

2. CUE Input Level Check Circuit (AE-05 Board)

If LINE is designated as the CUE input and +4dBm (J)/+8 dBm (UC/EK) input to the CUE IN connector, -8dBs will be output from pin 1 of CUE recording amplifier IC101. If MIC is inadvertently designated as the CUE input, the amplifier will saturate. To prevent this, the amplifier output is monitored by comparator IC115, and if the level of the output signal rises to +18dBs or more, the CUE input selection is forcibly switched to LINE.

3. CUE Recording Level Control Circuit (AE-05 Board)

The recording level can be varied between -70 and 0dB according to the gain control voltage (CUE REC G CONT) supplied from the RS-23 board. The playback circuit is also provided with a similar gain control circuit.

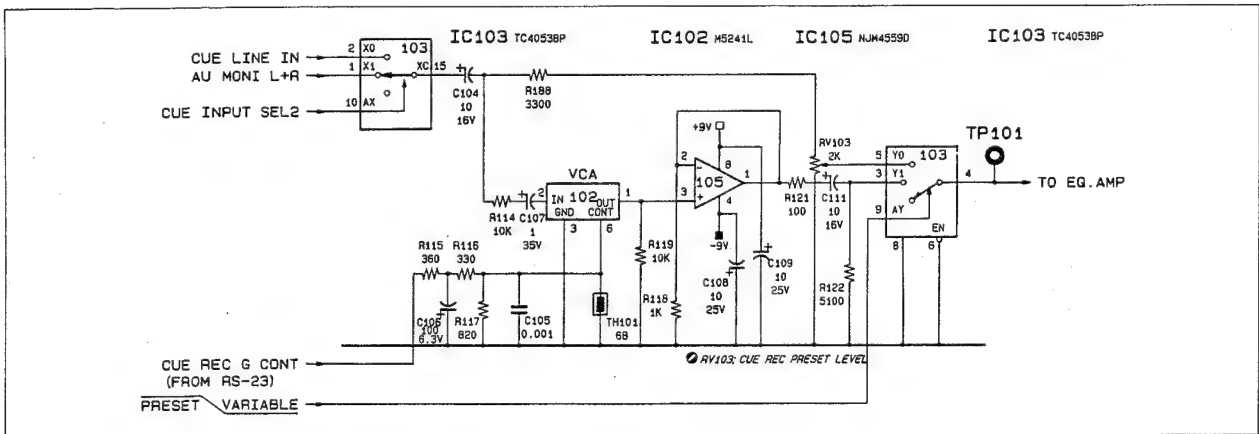

Fig. 2-4-3. CUE Recording Level Control Circuit (AE-05 Board)

4. CUE Recording Equalizer (AE-05 Board)

As shown in Fig. 2-4-4., the level of signals between 2 kHz and 5 kHz is raised gradually by IC105, and the level of signals in the high frequency range raised by IC106. The gain at 1 kHz is 47dB. Compensation of the frequency characteristics at high frequency is done by RV105.

5. CUE Bias Amplifier (AE-05 Board)

The Miller integrator circuit IC106 creates the rising and falling slopes of the bias signal. When the CUE REC signal output from pin 5 of IC401 is LOW level, the output from pin 7 of IC106 rises gradually from -12 V , and when it exceeds $+0.7\text{ V}$ D105 goes ON, then the voltage continues to rise slowly. Conversely, when the CUE REC signal is HIGH, the voltage falls in the opposite sequence. The times required for the voltage to rise and fall are the same because the charging and discharging circuits are identical. D103 and 104 reduce the delay in the start of integration in IC106.

The 111.8 kHz bias pulses generated by bias oscillator IC404 pass through the open-collector output type inverter IC412, and undergo level adjustment in RV106. The DC component of these pulses is cut by C126, and high frequency noise is removed by a low-pass filter consisting of C127, C128 and R138, which has a cut-off frequency of 800 kHz. The output from the low-pass filter is converted into a sine wave by a resonator circuit consisting of L101 and C129. The resulting signal is passed through buffer IC107, then once again through a resonator circuit consisting of LV101 and C130, then through a constant current resistor R145 to become the bias current which is then is supplied to the head.

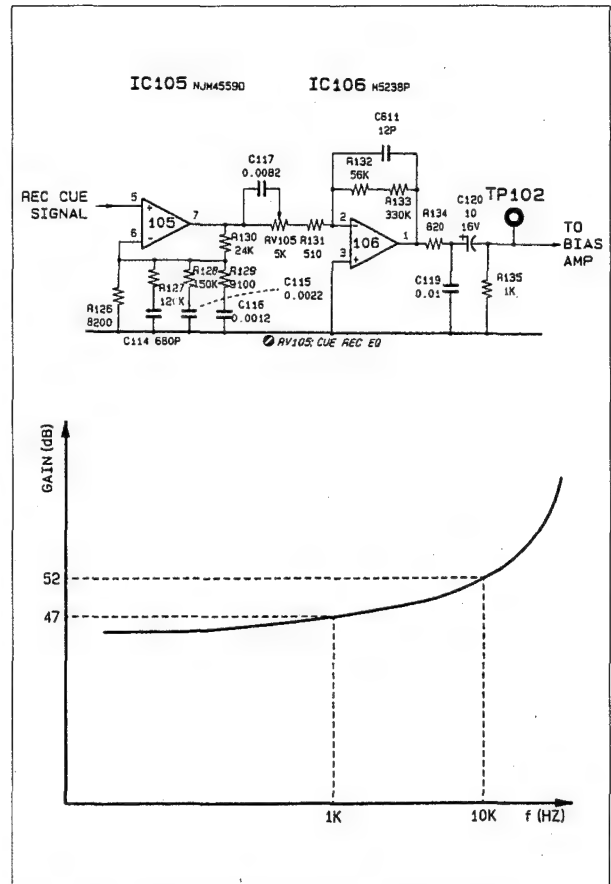

Fig. 2-4-4. CUE Recording Equalizer (AE-05 Board)

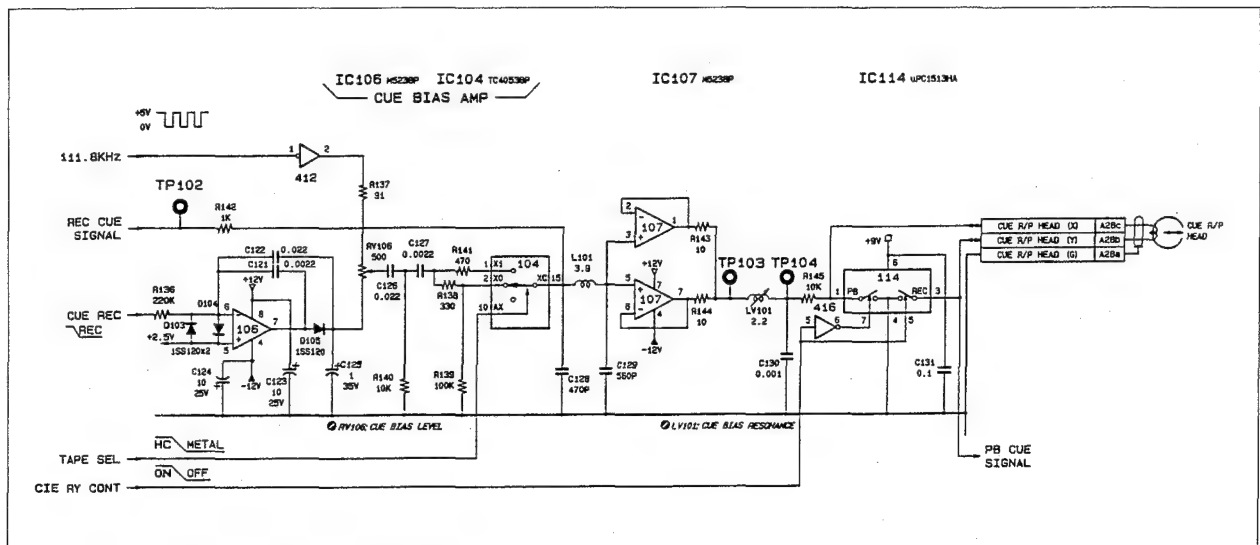

Fig. 2-4-5. CUE Bias Amplifier (AE-05 Board)

6. CUE Playback Amplifier (AE-05 Board)

In order to make the frequency characteristics of the playback CUE signal flat, the time constant in the low frequency region is made 3183 μsec (83dB), and in the high frequency region the frequency response falls at the rate of -6dB/oct up to a frequency of 100 kHz or higher. The gain of the amplifier at 1 kHz is 57dB.

7. CUE Playback Equalizer (AE-05 Board)

This equalizer consists of a secondary bypass filter comprising C139, C140, R155 and R158, which has a cutoff frequency of 50 Hz, and a bypass filter comprising C141 and R156, which has a cutoff frequency of 160 Hz. The time constant in the high frequency region is adjusted to 15 μsec (10.6 kHz) by RV107. Fig. 2-4-6. shows the previously mentioned playback amplifier and its overall frequency characteristics.

8. CUE Meter Amplifier (AE-05 Board)

In this circuit, the DC component of the CUE signal is cut by IC112 (1/2), and the level of the resulting signal is adjusted by RV109. IC111 is a full wave rectifier, the output of which is smoothed by IC112 (2/2) and used to determine the dynamic characteristics of the VU meter. The dynamic characteristics of the peak meter are determined by D109, R186, R187 and C161.

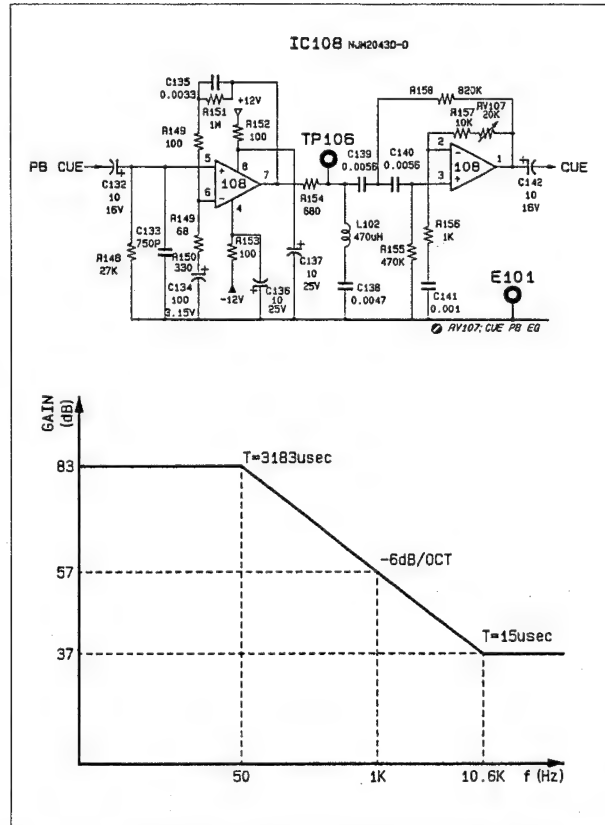

Fig. 2-4-6. CUE Playback Amplifier/Playback Equalizer Amplifier (AE-05 Board)

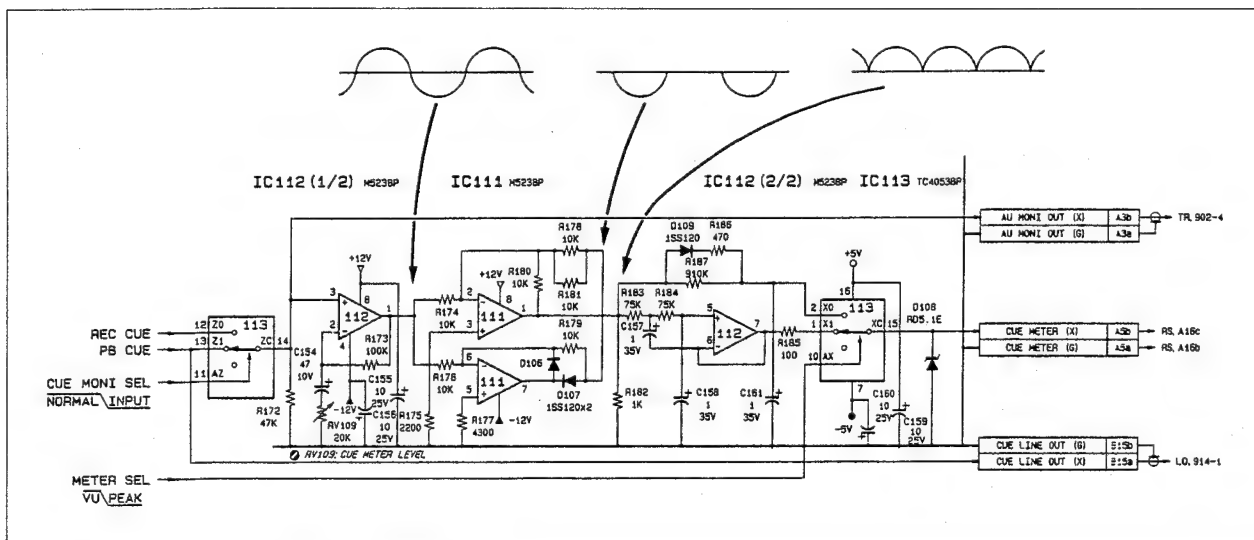

Fig. 2-4-7. CUE Meter Amplifier (AE-05 Board)

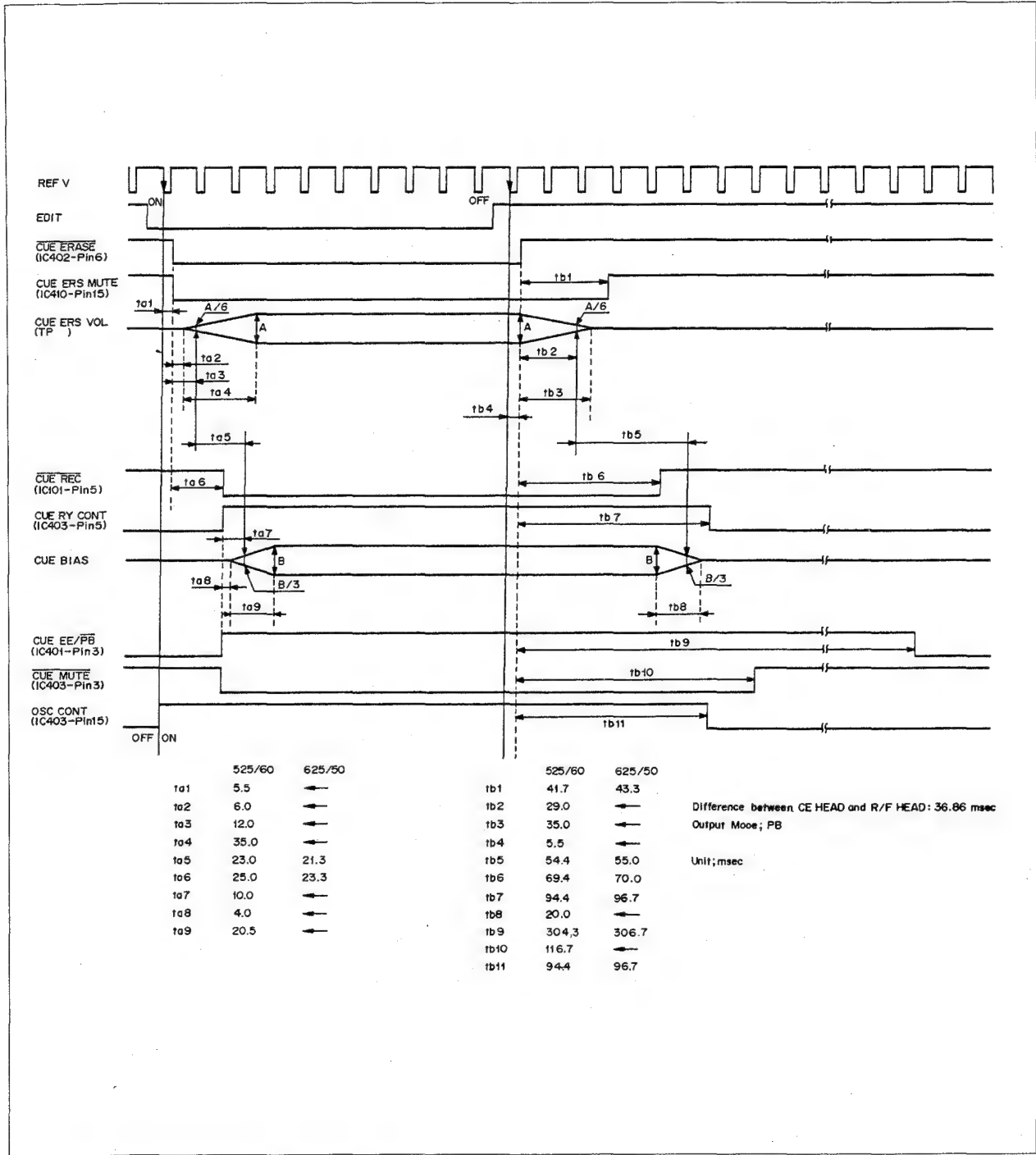

Fig. 2-4-8. Timing Chart (CUE Signal System)

4-2-5. Time Code Recording/Playback Circuit (AE-05 Board)

1. Time Code Wave Shaping Circuit (AE-05 Board)

Comparator IC202 has ± 0.3 V hysteresis with respect to the threshold level. In other words, when the level of the time code input to this comparator is 0.6 Vp-p or greater, it is converted into the TTL level then output.

2. Time Code Input Level Check Circuit (AE-05 Board)

This circuit consists of IC405 and IC406. When a standard level (2.4 Vp-p) time code is input, 4.8 Vp-p is output from pin 7 of IC201. When the time code input is 0.5 Vp-p or less, the output from pin 7 of IC202 becomes 1 Vp-p or lower, so that it fails to reach the threshold value (0.5 V) of comparator IC405 (1/2). As a result, pin 9 of the D type flip-flop IC406 becomes LOW level, informing the system control system that the input time code level is low.

Conversely, when the input time code level is higher than 5.0 Vp-p, the voltage of pin 7 of IC201 becomes 10 Vp-p or higher, so that it exceeds the threshold value (5 V) of comparator IC405 (2/2). As a result, pin 6 of IC406 becomes LOW, informing the system control system that the input time code level is high.

3. Time Code Recording Equalizer (AE-05 Board)

The recording time code signal is provided with the following frequency characteristics for waveform compensation.

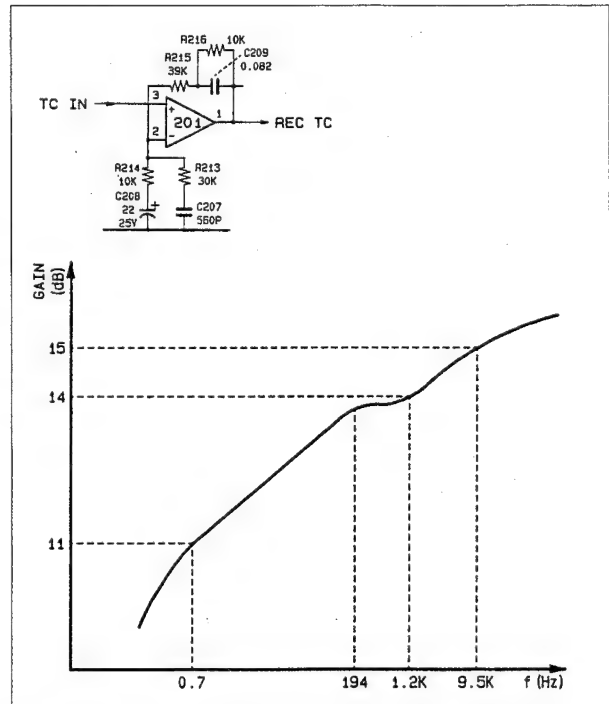

Fig. 2-5-2. Time Code Recording Equalizer (AE-05 Board)

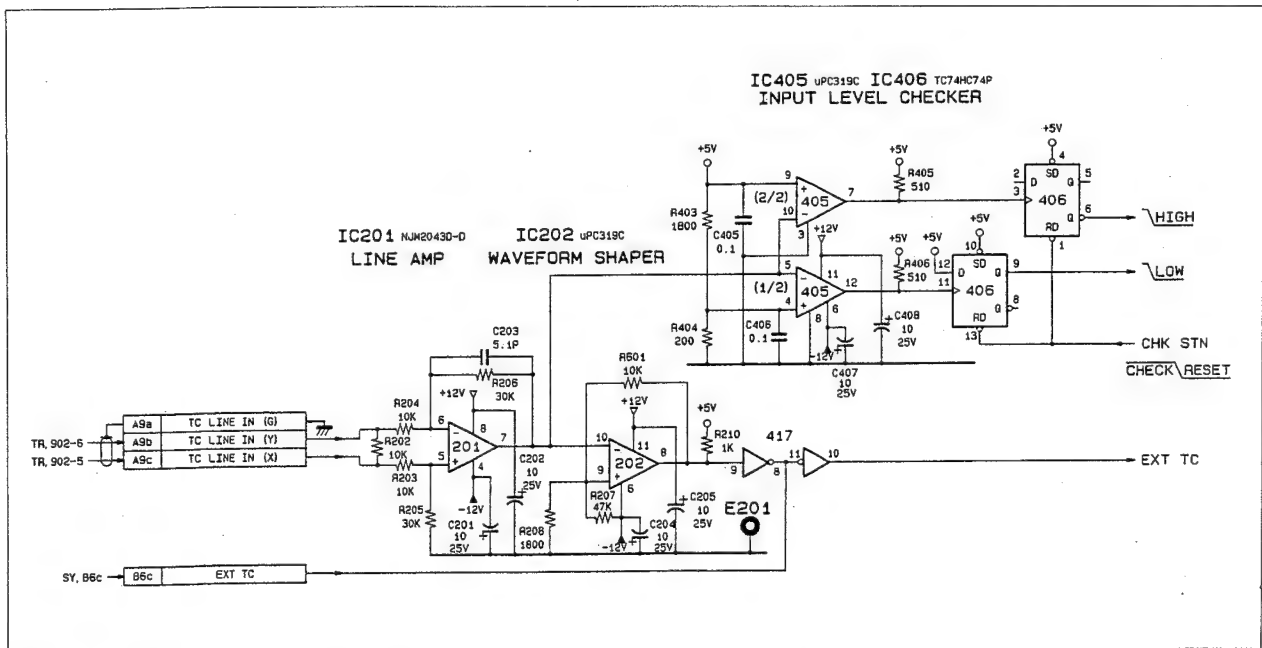

Fig. 2-5-1. Time Code Wave Shaping/Input Level Check Circuit (AE-05 Board)

4. Time Code Bias Amplifier (AE-05 Board)

The Miller integrator IC205 creates the slopes for the rise and fall of the bias signal. When the TC REC signal becomes LOW level, the output from pin 1 of IC205 rises gradually from -12 V, and when it exceeds +0.7 V D203 goes ON, then the voltage continues to rise slowly. D201 and 202 reduce the delay in the start of integration in IC205. Conversely, when the TC REC signal is HIGH level, the bias falls in the opposite sequence. The times required for the bias to rise and fall are the same because the charging and discharging circuits are identical.

The 111.8 kHz pulses generated in IC404 pass through an open collector output type inverter IC412, then to RV202 where they undergo level adjustment. The DC component of these pulses is cut by C214, then high frequency noise is removed by a low-pass filter consisting of C215, C216 and R222, which has a cut-off frequency of 800 kHz. The output from the low-pass filter is converted into a sine wave by a resonator circuit consisting of L201 and C217. The resulting signal is passed through buffer IC206, then once again through a resonator circuit consisting of LV201 and C220, to become the bias current that is supplied to the head.

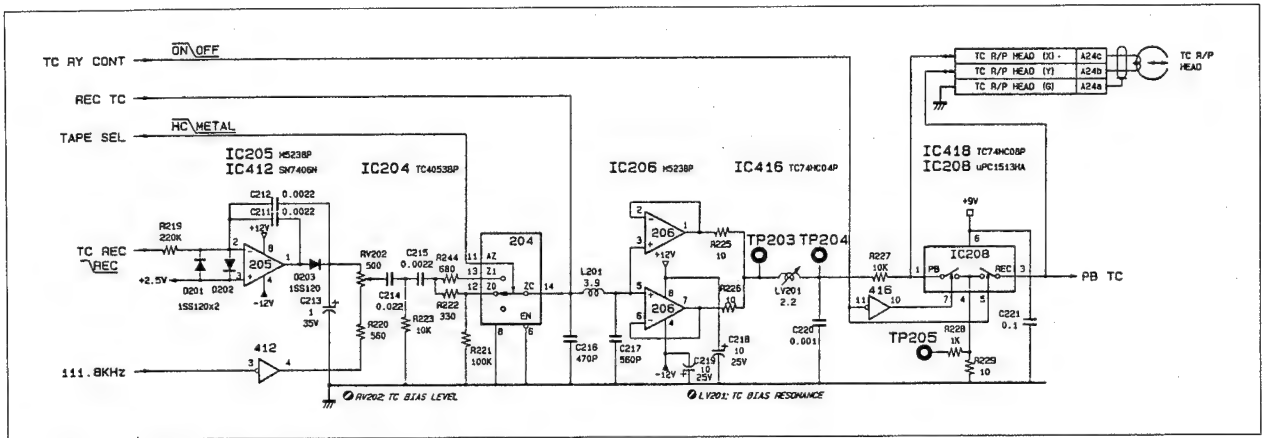

Fig. 2-5-3. Time Code Bias Amplifier (AE-05 Board)

5. Time Code Playback Equalizer (AE-05 Board)

The time constant of the equalizer amplifier alone is 1473 μ sec in the low frequency range, and 12.6 μ sec in the high frequency range (solid line in Fig. 2-5-4.). The cut-off frequency of the low-pass filter consisting of the L component of the R/P head and R230 is 12.6 kHz (time constant 12.6 μ sec) (dotted line in the figure). Consequently, by combining both characteristics,

an attenuation of -6dB/oct will be obtained in the high frequency region. The playback time code during FF/REW is 96 kHz max (x 40 speed x 2.4 kHz), hence because the overall characteristics shown in Fig. 2-5-4. are attenuated at a rate of -6dB/oct up to 100 kHz and those of the playback head, which is a differential type, increase at a rate of +6dB/oct, the time code can be read when the tape is traveling at high speed.

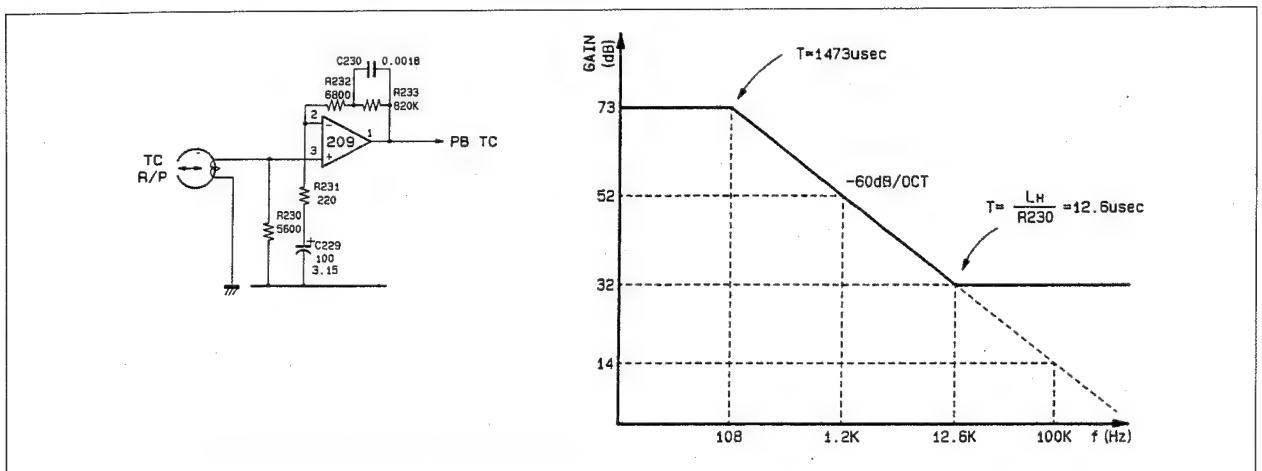

Fig. 2-5-4. Time Code Playback Equalizer (AE-05 Board)

6. Playback Time Code Wave-shaping Circuit (AE-05 Board)
 The threshold level of comparator IC202 has a hysteresis of ± 0.5 V. When the input time code level is 1.0 Vp-p or more, it is converted to a TTL level and output.

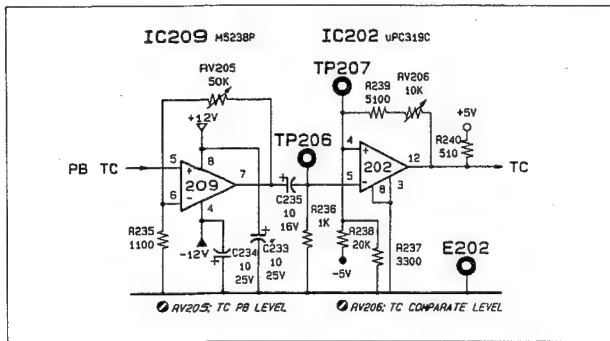

Fig. 2-5-5. Playback Time Code Wave-shaping Circuit (AE-05 Board)

7. Time Code Output Wave-shaping Circuit (AE-05 Board)
 This is an integrator circuit which is designed to create a time constant of 25 μ sec (525/60 system) or 50 μ sec (625/50 system) for the TTL level playback time code pulses in the NORMAL FORWARD mode.

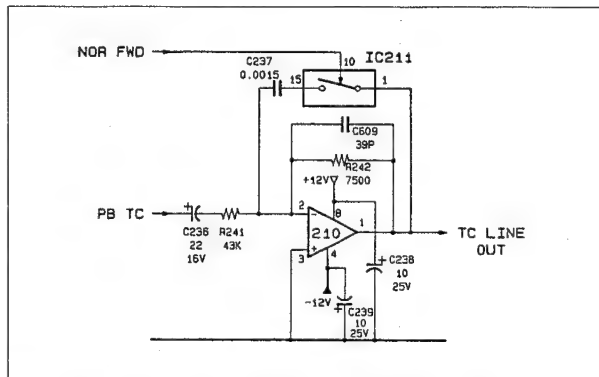

Fig. 2-5-6. Time Code Output Wave-shaping Circuit (AE-05 Board)

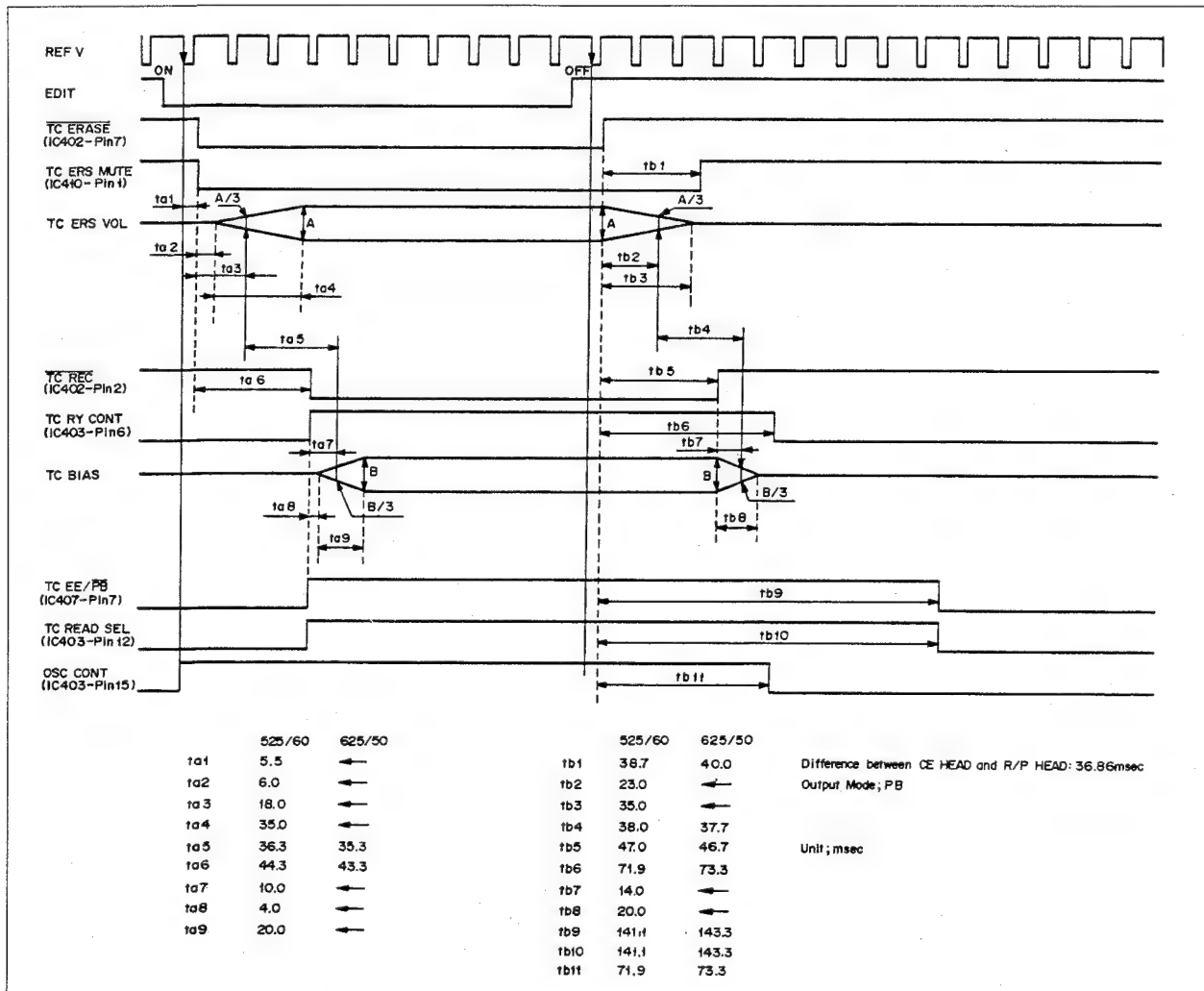

Fig. 2-5-7. Timing Chart (Time Code System)

4-2-6. CTL Recording/Playback Circuit (AE-05 Board)

1. CTL Recording Amplifier (AE-05 Board)

This board provides the frequency characteristics shown in the figure below for the CTL signal, to compensate for the waveform characteristics.

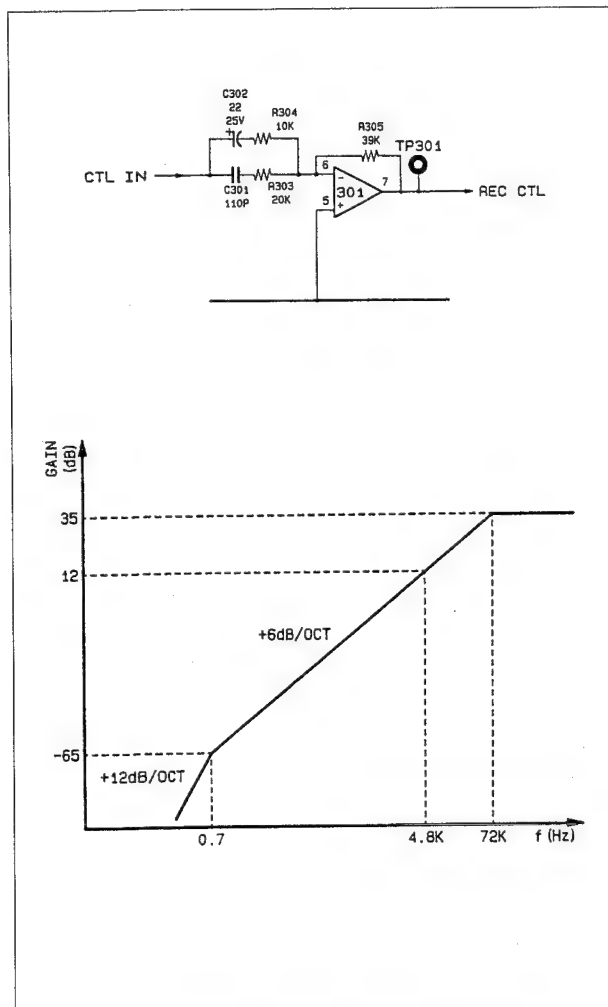

Fig. 2-6-1. CTL Recording Amplifier (AE-05 Board)

2. CTL Playback Equalizer (AE-05 Board)

The time constant of the equalizer amplifier alone is 4547 μ sec in the low frequency range, and 5.4 μ sec in the high frequency range (solid line in Fig. 2-6-2.). The cutoff frequency of the low-pass filter formed by the L component of the R/P head and R316 is 29.3 kHz (time constant 5.4 μ sec) (dotted line in the figure). Consequently, by combining both characteristics, an attenuation of -6dB/oct will be obtained in the high frequency region. The playback CTL during FF/REW is 192 kHz max (x 40 speed x 4.8 kHz), hence because the overall characteristics shown in Fig. 2-6-2. are attenuated at a rate of -6dB/oct up to 200 kHz and those of the playback head, which is a differential type, increase at a rate of +6dB/oct, the CTL can be read when the tape is traveling at high speed.

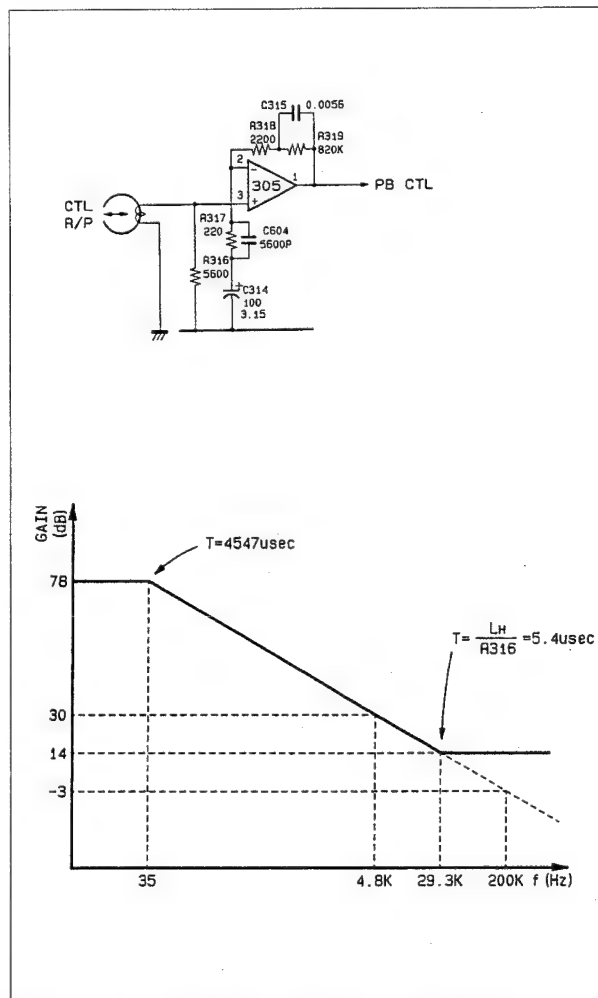

Fig. 2-6-2. CTL Playback Equalizer (AE-05 Board)

3. Playback CTL Wave-shaping Circuit (AE-05 Board)

The threshold level of comparator IC306 has a hysteresis of ± 0.7 V. When the input time code level is 1.4 V_{p-p} or higher, it is converted to a TTL level and output.

4-2-7. Crosstalk Canceler (AE-05 Board)

This circuit prevents the time code recording signal from leaking to the CTL playback circuit in the TC INSERT mode. The waveform of the time code signal is adjusted by IC207 (1/2) and the phase by IC207 (2/2). In addition, the level is adjusted by RV303, then the signal is supplied to the CTL playback amplifier. In this way, crosstalk is canceled.

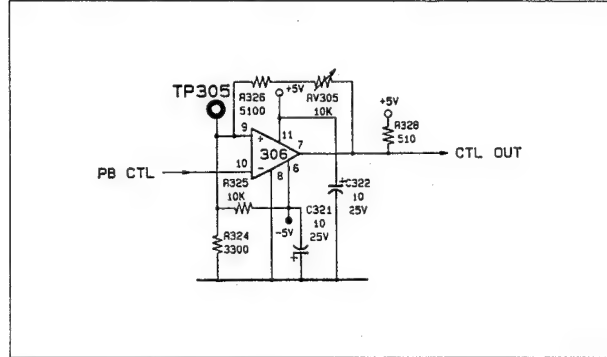

Fig. 2-6-3. CTL Wave-shaping Circuit (AE-05 Board)

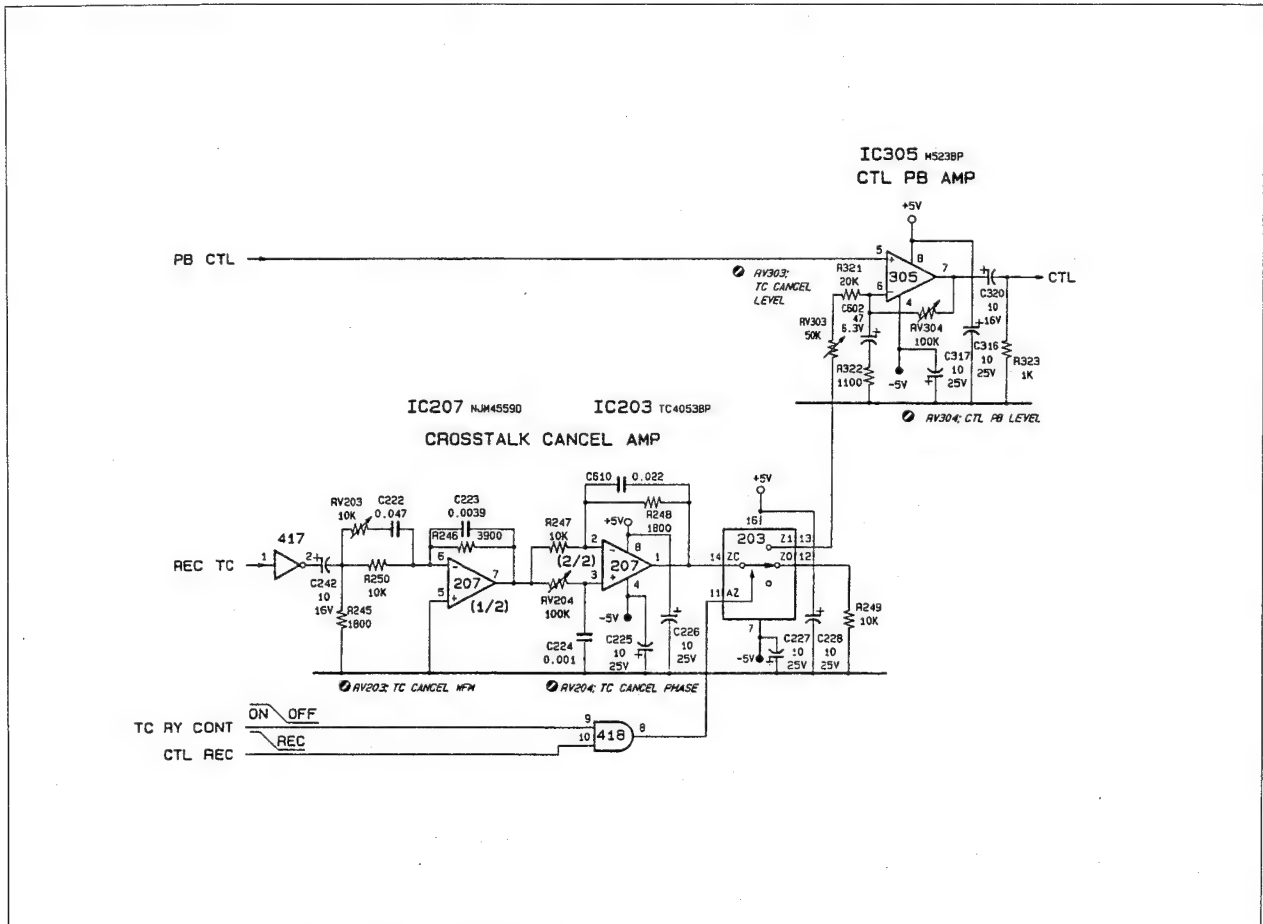

Fig. 2-7-1. TC → CTL Crosstalk Canceler (AE-05 Board)

4-2-8. Erase Amplifier (AE-05 Board)

This circuit consists of a CUE erase amplifier, time code erase amplifier and FULL/CTL erase amplifier. The circuit configuration of the CUE erase amplifier and time code erase amplifier is the same. The FULL/CTL erase amplifier also has roughly the same circuit configuration except that at low temperature resonance deviation occurs due to the L component of the head, reducing the erase current. To overcome this, temperature compensation is performed by thermistor TH601. The CUE erase amplifier is described below by way of an example.

The Miller integrator IC501 creates the rising and falling slopes of the bias signal. When the CUE ERASE signal is LOW level, the output from pin 1 of IC501 rises gradually from -12 V, and when it exceeds +0.7 V the voltage continues to rise slowly. D501 and 502 reduce the delay in the start of integration in IC501. Conversely, when the CUE ERASE signal is HIGH level, the erase signal falls in the opposite

sequence. The times required for the voltage to rise and fall are the same because the charging and discharging circuits are identical.

The 111.8 kHz pulses generated by IC404 pass through the open-collector output type inverter IC412, and are then supplied to this circuit. RV501 is a level adjustment potentiometer. The DC component of these pulses is cut by C512, and high frequency noise is removed by a low-pass filter consisting of R503 and C513, which has a cut-off frequency of 960 kHz. The output from the low-pass filter is converted into a sine wave by a resonator circuit consisting of L505 and C514. The resulting signal is passed through buffer IC501, then through a current booster consisting of Q501 and 502, then through a series resonator circuit consisting of C519 and LV501 and the erase head, to the erase head itself. When the tape is not being erased, the analog switch IC504 is turned ON to reduce the Q of the resonator circuit in order to reduce the crosstalk from the erase current.

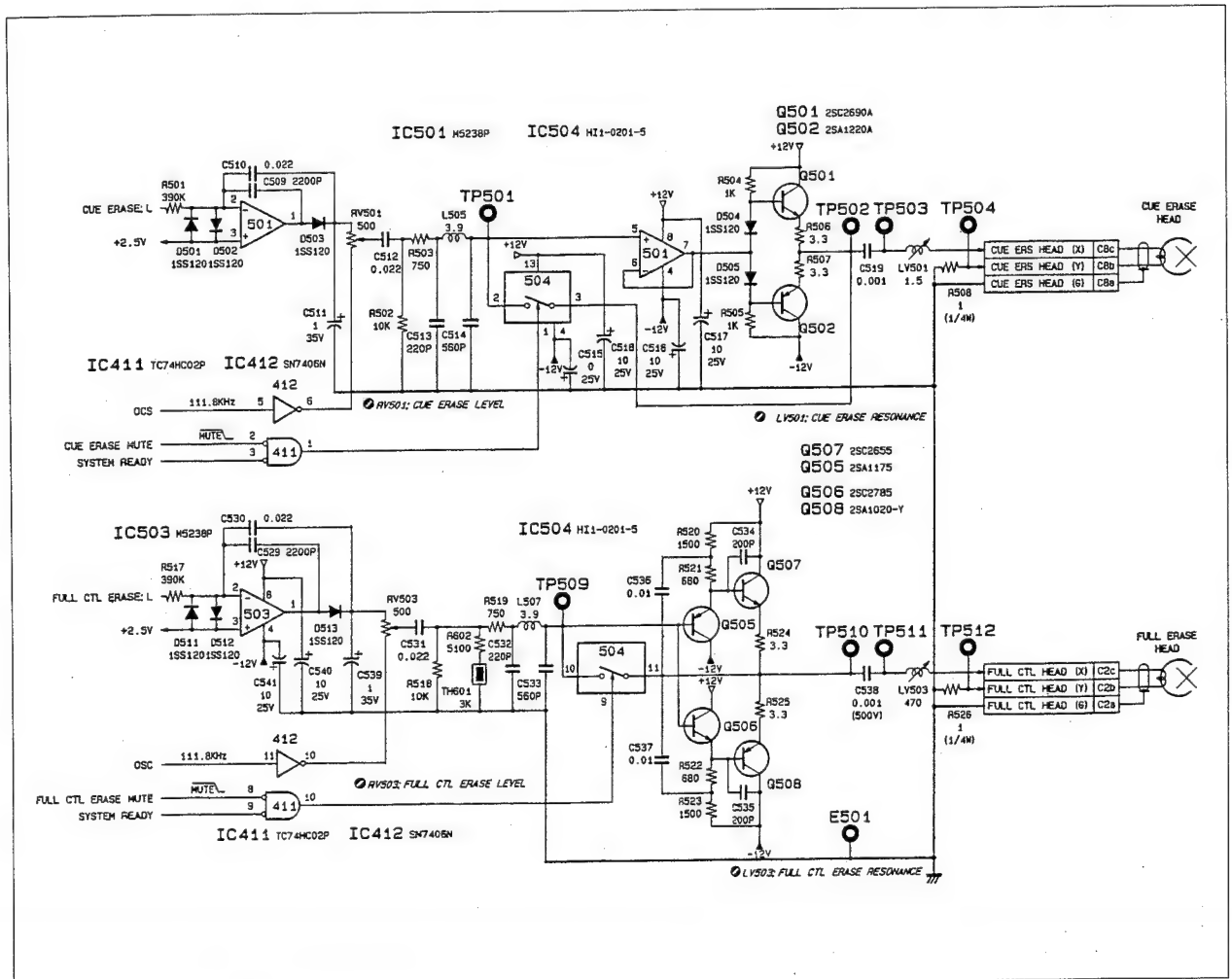

Fig. 2-8-1. Erase Amplifier (AE-05 Board)

4-2-9. Audio Monitor Output Amplifier (TR-40 Board)

The audio monitor output consists of either the digital audio signal supplied from the DVPC-1000 or the CUE signal. The digital audio signal is differentially input at a level of -20 dBm. This signal is made the same level as the CUE signal (-26dB) by IC4, then input to IC3. At IC3, the monitor output signal is selected according to the content of the "AU MONI L/R SEL" signal supplied from the SP-01 board, then output to the next level control circuit. IC2 is a current input/current output voltage control amplifier. It varies the monitor output level over the range between 0dB and -60dB according to the "AU MONI LG/RG CONT" signal from the CD-35 board. TH1 and 2 and R48 and 49 are for temperature compensation.

The level control signal from the CD-35 board is sent at intervals of V in a 525/60 system, or at 40 msec intervals in a 625/50 system. Consequently, the output signal changes in steps, resulting in noise. To prevent this, the control signal is rounded off by a low-pass filter consisting of R51 and C36 (or R50 and C35) thus ensuring that the level changes take place smoothly.

The level-adjusted monitor signal is amplified by a factor of 20 by monitor amplifier IC1, then output via a muting circuit consisting of Q7, 8, 9 and 10 in the next stage. Muting takes place according to the status of the "SYSTEM READY" signal supplied from the SP-01 board. When the power is switched ON or OFF, the "SYSTEM READY" signal becomes high impedance, causing the headphone output and monitor output to be muted.

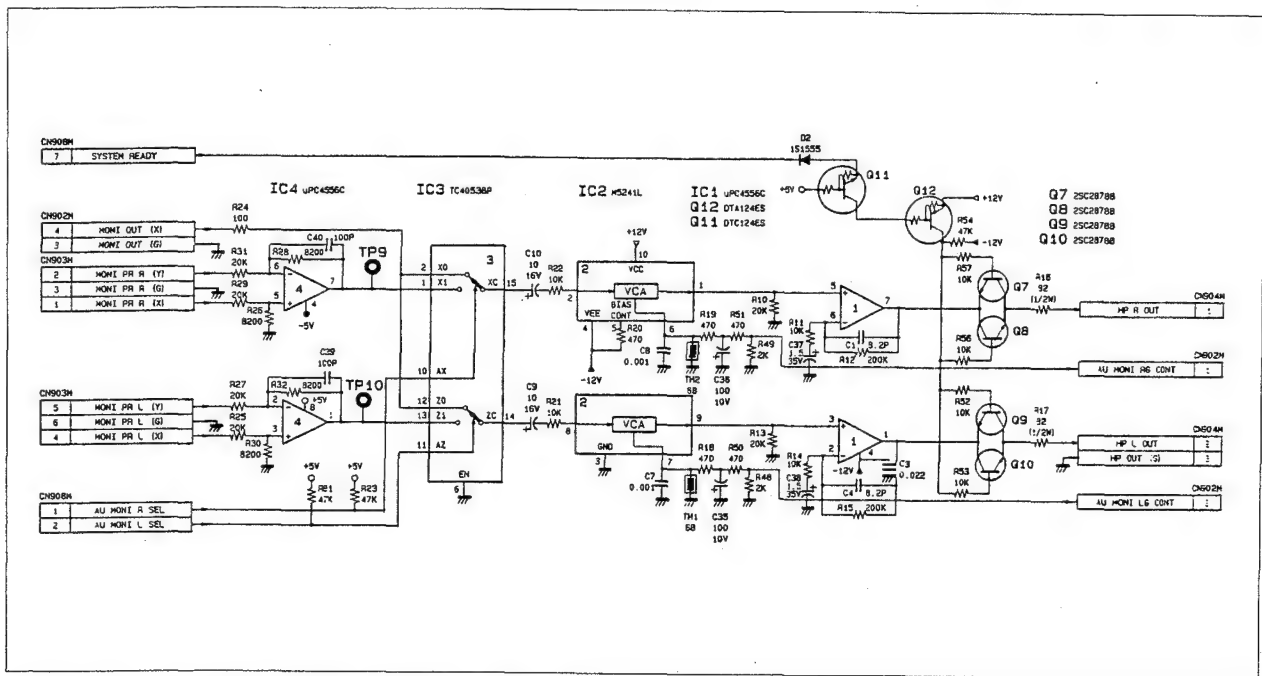

Fig. 2-9-1. Audio Monitor Output Amplifier (TR-40 Board)

4-2-10. Waveform Monitor Output Signal Select Circuit (TR-40 Board)

One of the following signals is output from the WFM OUT MONITOR connector.

- Playback RF envelope signal from playback heads A to D
- CTL signal

The signal to be output is designated from the control panel. In this circuit, the control signal is sent by a serial interface from the SP-01 board.

The playback envelope signal from the RF-15 board is input to select circuit IC9 via buffers IC5 and 6. The level of the input signal is between 0 and 3.3 V. Here, one channel is selected according to the control signal from the SP-01 board. The

selected signal is attenuated to 1.0 Vp-p by the attenuator R43 and R45, a GND level is inserted periodically by oscillator IC7 and the clamp circuit Q4, then the resulting signal is input to the RF ENV/CTL select circuit IC3.

Meanwhile, the CTL signal supplied from the AE-05 board is attenuated from 5 Vp-p to 1 Vp-p by the attenuator R40, 41, then passes through buffer IC8 to the RF ENV/CTL select circuit IC3.

At IC3, the RF envelope or CTL is selected according to the contents of the control signal from the SP-01 board, and the selected signal is output via buffer IC8 from the WFM OUT MONITOR connector.

The SV REF signal passes through the buffer Q5, 6, and is output from the WFM OUT TRIGGER connector.

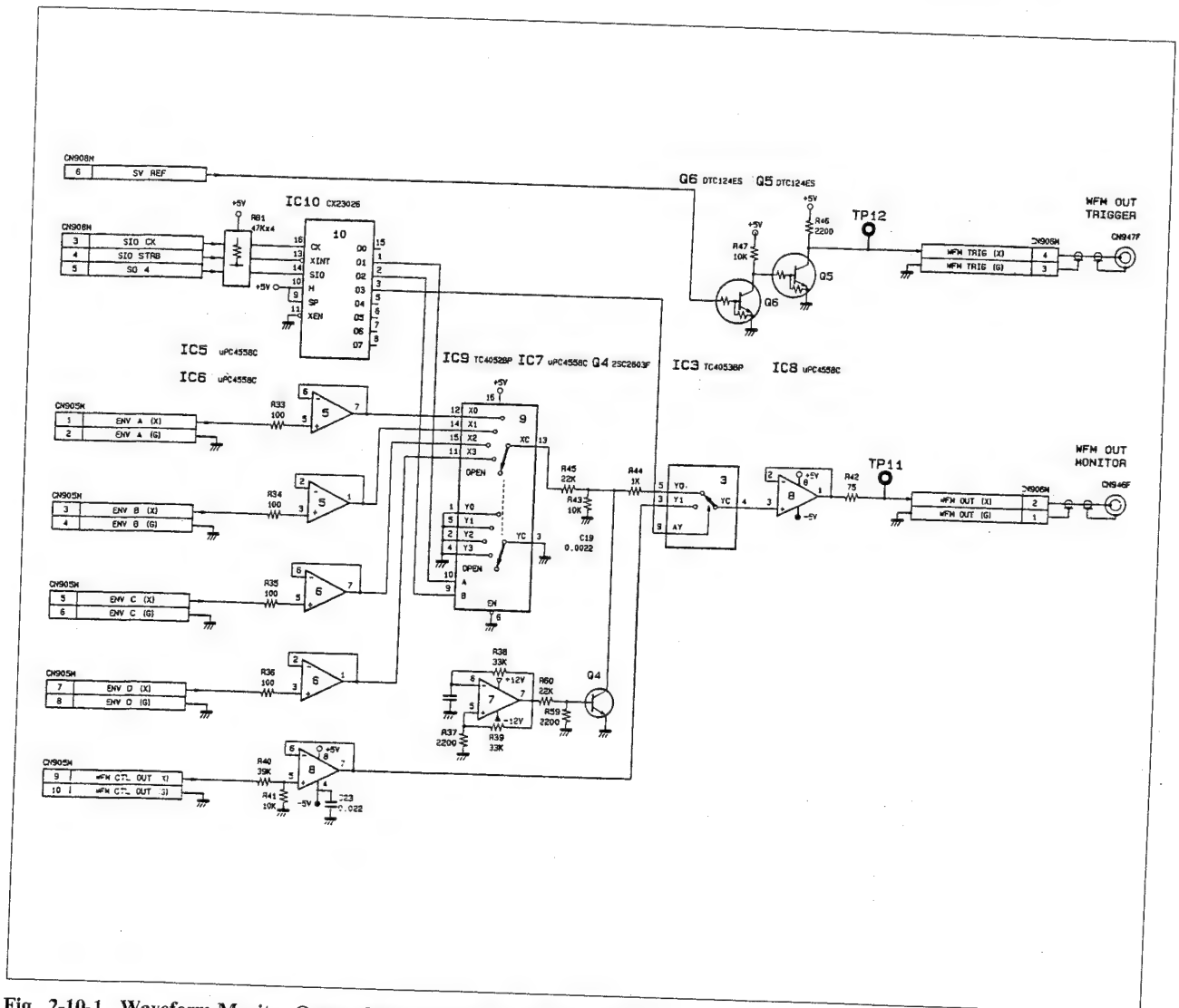

Fig. 2-10-1. Waveform Monitor Output Signal Select Circuit (TR-40 Board)

4-2-11. Line Output Amplifier (LO-05 Board)

The line output amplifiers for the CUE, TC and MONITOR OUT L/R channels are of roughly the same construction, hence a description of the CUE amplifier alone is given below. The CUE line output amplifier consists of IC1 and Q1 to Q8. The CUE signal sent from the AE-05 board is amplified by IC1, the peak level clipped by D5 and D6, and the resulting signal sent to Q3 and Q4. Q1/2, Q3/4 and Q5/6 constitute a current mirror circuit. Q3 and Q4 are driven by low current, and idle current is passed through Q7 and Q8 in order to prevent crossover distortion.

IC1 in the feedback loop is a DC servo circuit which prevents DC current from flowing through the primary side of transformer 1.

The CUE signal which is output from the line amplifier passes through output transformer T1 and is output from the CUE OUT connector. The output impedance of transformer T1 is set at 600 Ω , however it can be converted to 150 Ω or 37.5 Ω by connecting the windings of transformer 2 in series or in parallel.

4-2-12. Muting Circuit (LO-05 Board)

A muting circuit using a relay is installed to prevent noise from appearing at the line when the power is switched ON/OFF. Muting takes place according to the SYSTEM READY signal supplied from the SP-01 board.

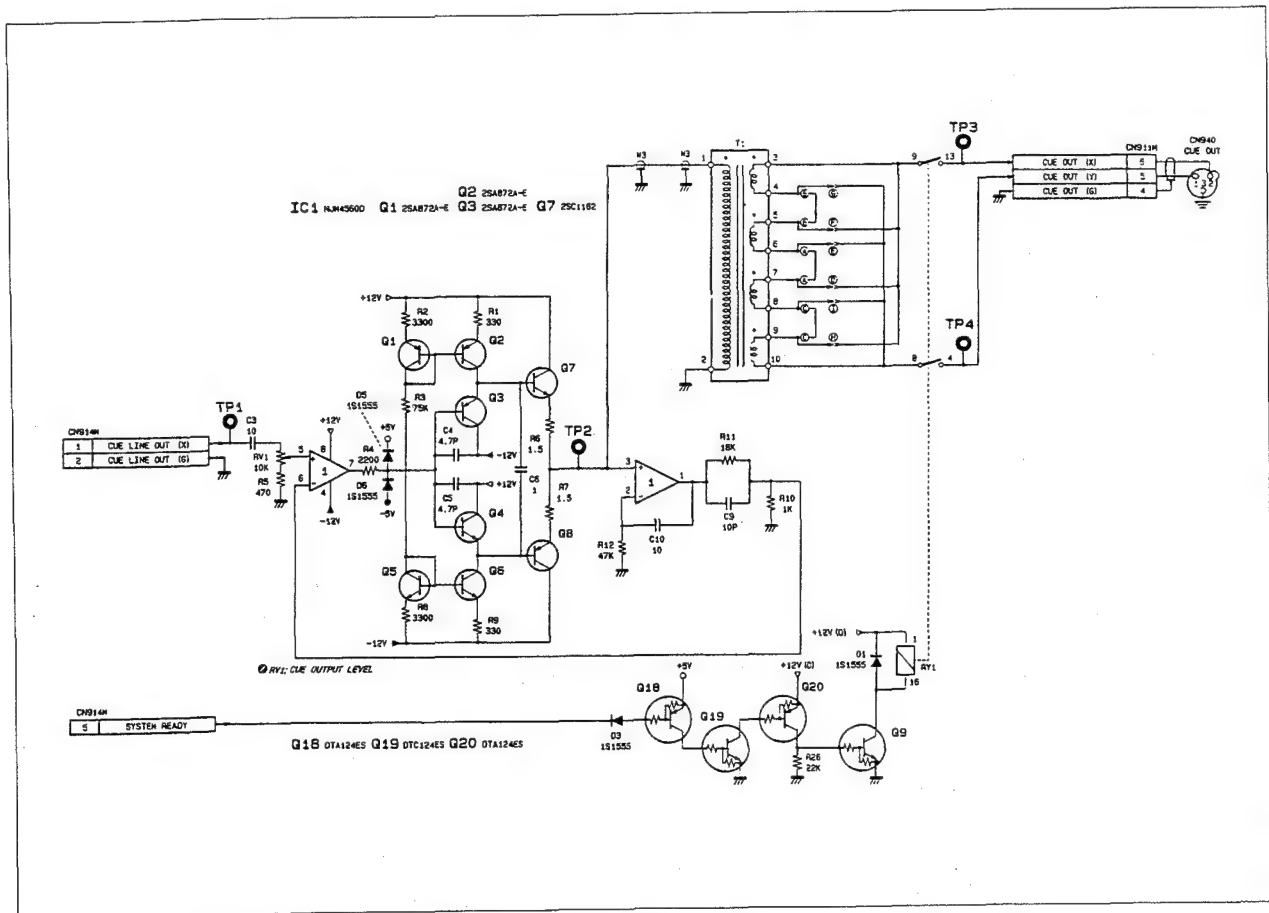

Fig. 2-11-1. Line Output Amplifier (CUE Channel/LO-05 Board)

4-3. RF SIGNAL SYSTEM (RF-15 BOARD)

The RF-15 board consists of the recording drive amplifier circuit, playback equalizer circuit, and peripheral equipment. The recording drive amplifier and the playback equalizer both consist of ICs. The necessary processing parameters are sent from the SP-01 board via a serial interface.

The following description concerns RF-15 boards whose board numbers are suffixed with "-11".

4-3-1. Recording Drive Amplifier (IC1, 2, 3 and 4/RF-15 Board)

This amplifier performs recording equalization of recording data supplied from the DVPC-1000, and outputs data to the recording amplifier inside the head drum.

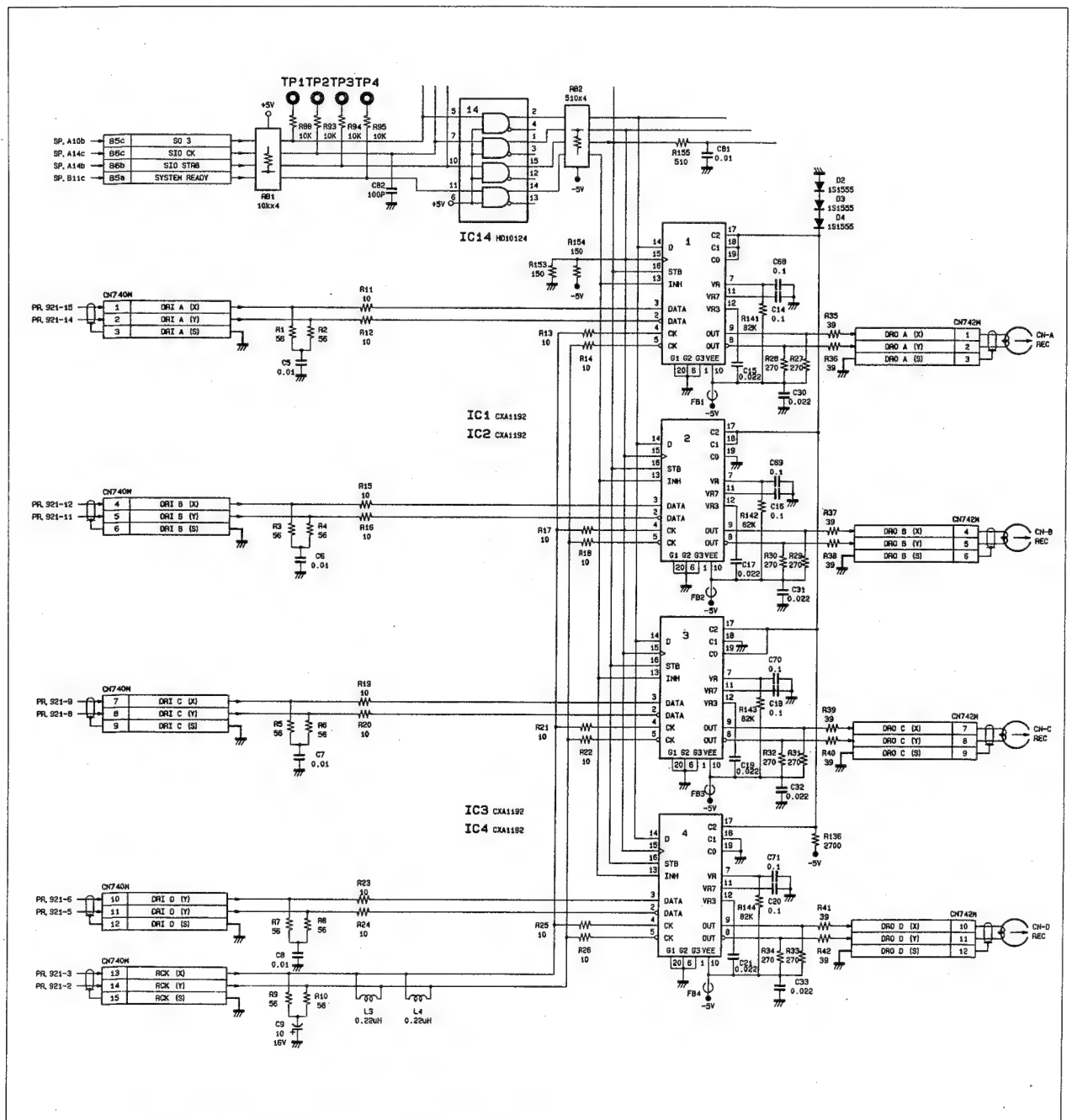

Fig. 3-1-1. Recording Drive Amplifier (IC1, 2, 3, 4/RF-15 Board)

(A) Recording Current (RF-15 Board)

A current proportional to the output level of the drive amplifier (IC1, 2, 3, 4) flows to the recording head. The output level of the drive amplifier is controlled by 6-bit control data. It can be varied through a range of 64 steps. The output varies more or less linearly between the minimum and maximum levels, as shown in Fig. 3-1-2. Fig. 3-1-2. shows the 6-bit control data and also the relationship between the output from the drive amplifier and the recording current under no load (when the drum is not connected).

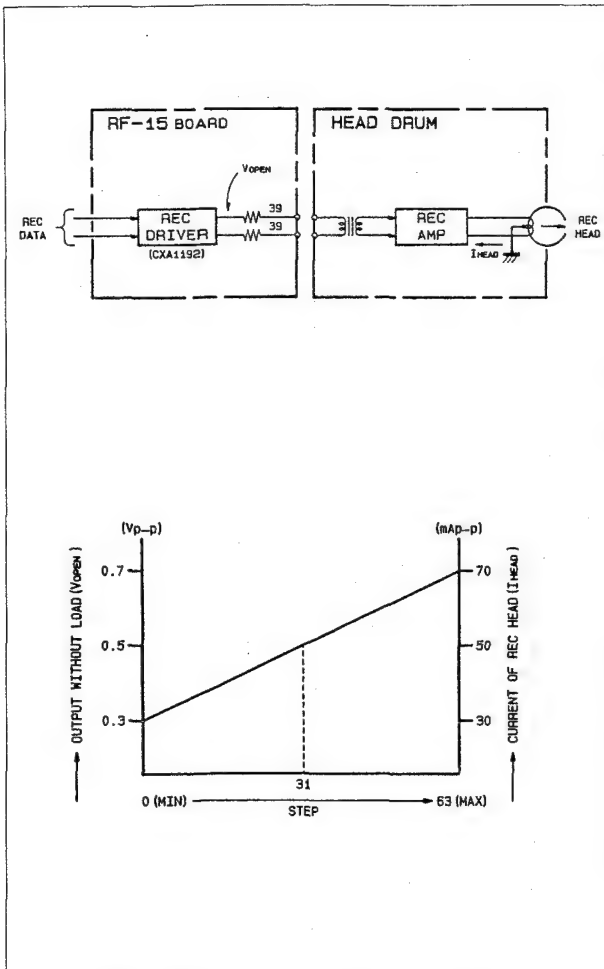

Fig. 3-1-2. Recording Drive Amplifier Output Characteristics (RF-15 Board)

(B) DC Balance (RF-15 Board)

This circuit compensates for DC distortion due to the DC erase and also imbalance between the recording head windings. Actual compensation is performed by varying the duty (duty of the recording current) by delaying the phase of the rise and fall of the recording data in steps.

As shown in Fig. 3-1-3., DUTY+ causes the recording current to vary in the direction such that the duty of the "0" level increases, and DUTY- causes the recording current to vary in the direction such that the duty of the "1" level increases. One duty step is about 0.5 nsec. Normally, DC erase operates in the "1" direction, hence duty compensation is often used with "+".

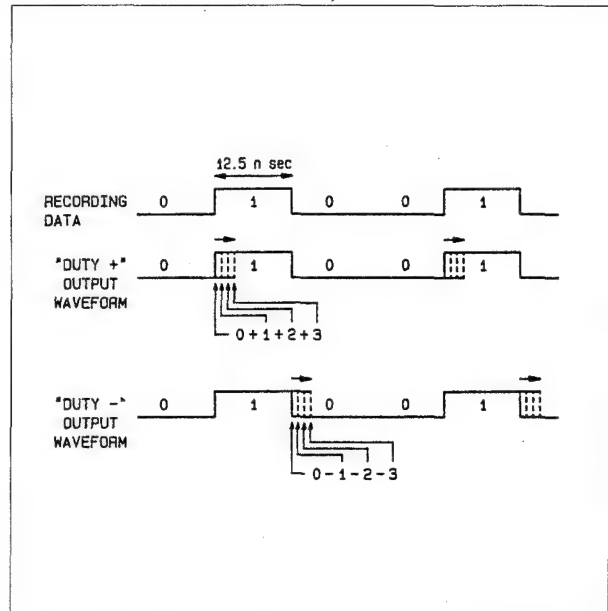

Fig. 3-1-3. Duty Compensation (RF-15 Board)

(C) Peak Shift Compensation (RF-15 Board)

As shown in Fig. 3-1-4., when several "1" or "0" level bits in the recording data appear continuously, the inversion bit following them produces a reduced output. This phenomenon is largely responsible for determining the overall error rate. This phenomenon is called peak shift.

Consequently, when performing digital recording at short wavelengths it is necessary to perform peak shift compensation. This is done by phase modulation in the DVR-1000. In other words, as shown in Fig. 3-1-5., the continuous bit length "L" is detected and the inversion position (A) after the continuous bits is shifted to the front by external data input in advance. One shift step is about 0.5 nsec. As the continuous bit length "L" increases in size, the shift of the inversion position also increases.

(D) REC Enable (RF-15 Board)

The recording drive amplifier (IC1, 2, 3, 4) goes into the recording mode only when the following conditions are satisfied. This is to prevent a recorded tape from being accidentally erased.

- The SYSTEM READY signal supplied from the SP-01 board must be HIGH level.
- The REC ENABLE signal sent from the SP-01 board via the serial interface must be LOW level.
- The recording data from the DVPC-1000 must not be in the same phase. (The recording data is normally sent at a differential level. In the DVPC-1000, however, blanking portion or the unit is in the non-recording mode, both differential outputs are made LOW level and used as a DISABLE signal.)

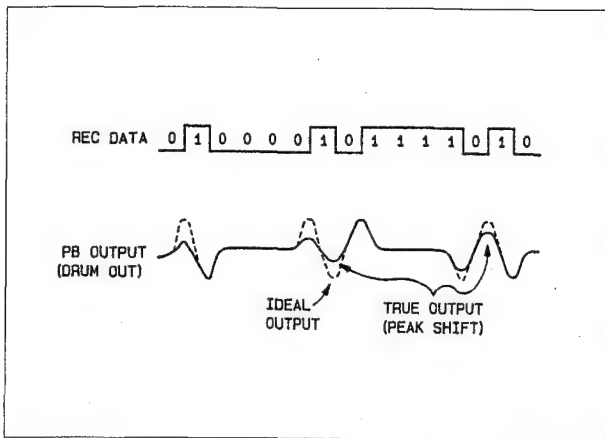

Fig. 3-1-4. Example of Peak Shift (RF-15 Board)

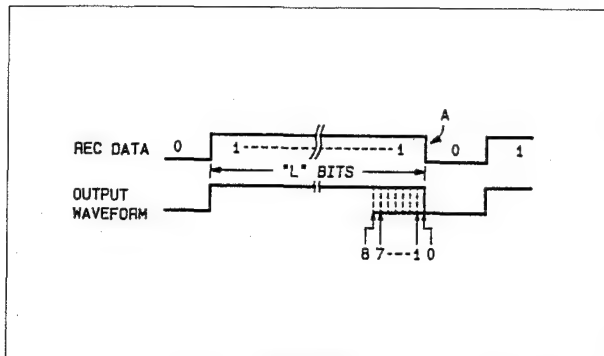

Fig. 3-1-5. Peak Shift Compensation by Phase Modulation (RF-15 Board)

4-3-2. Playback Equalizer (IC5, 6, 7, 8/RF-15 Board)

Playback equalization is applied to the playback signal from the head drum, converting it into ECL level digital data. At the same time, the eye pattern monitor signal, the envelope monitor signal, and the drop-out information are output. With the exception of the LPF section, all of the above functions are contained in a single chip.

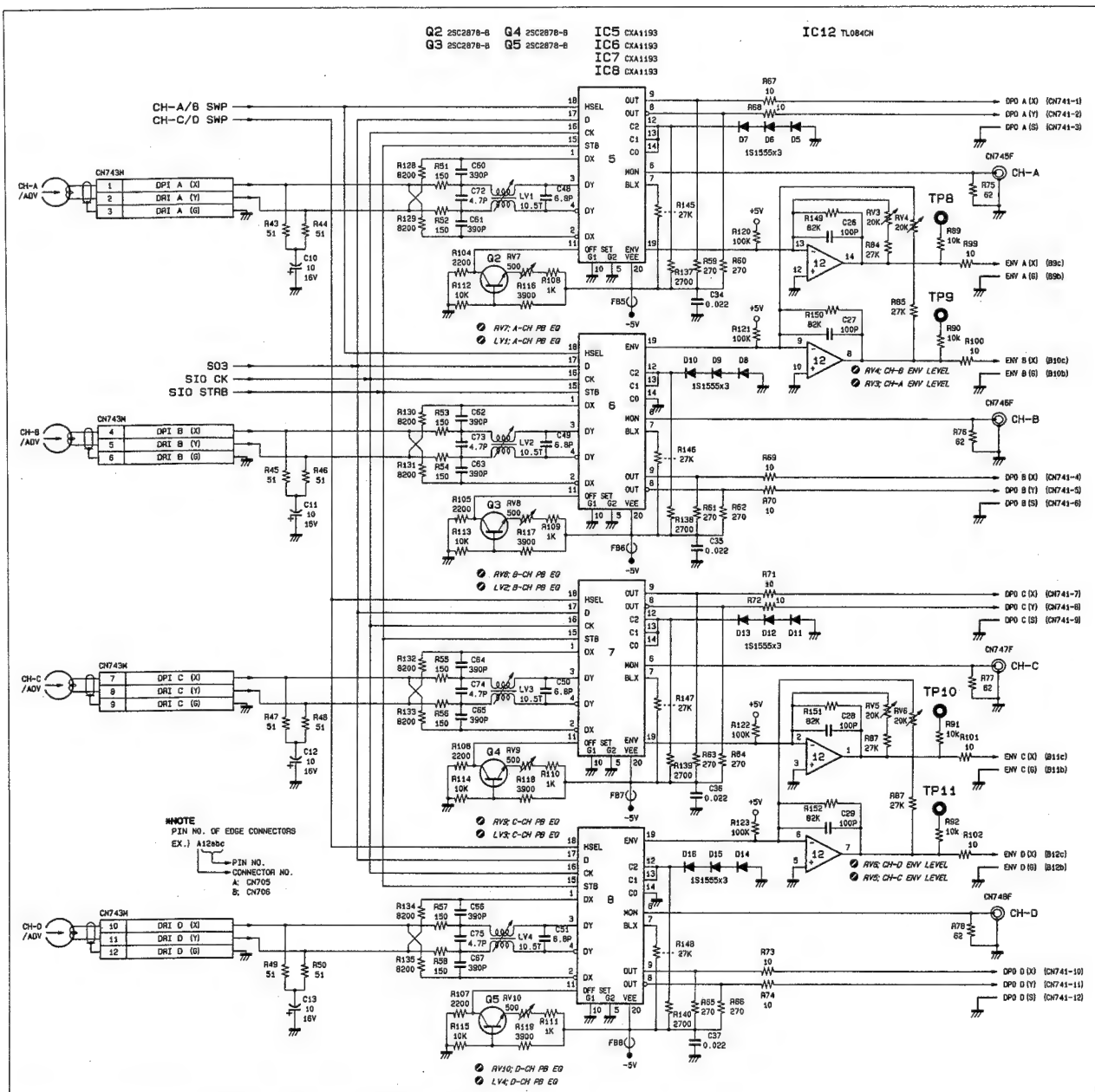

Fig. 3-2-1. Playback Equalizer (IC5, 6, 7, 8/RF-15 Board)

(A) Low-pass Filter (RF-15 Board)

This is a 3-stage low-pass filter consisting of capacitors and inductors. It has the following characteristics.

- A bifilar wound variable inductor is used for the differential input.
- By using this filter as a delay device, a kind of transversal filter is formed in combination with the adder in the equalizer IC, which functions as a COSINE filter.

(B) Frequency Equalizer (RF-15 Board)

The magnitude of the playback signal from the head increases in the low frequency region at 6 dB/oct, reaches a peak in the vicinity of 5 MHz, then drops abruptly because of various losses. To compensate for this, frequency equalization is performed, thus reducing waveform interference.

The playback equalizer (IC5, 6, 7, 8) performs equalization using the following three parameters.

- GAIN 1: High frequency gain
- GAIN 2: Gain over entire bandwidth
- PHASE: High frequency phase

These parameters are controlled by 6-bit control data, enabling them to be varied through a maximum of 64 steps. Low frequency compensation is performed by quantized feedback, and the level is kept fixed.

(C) AGC (RF-15 Board)

When quantified feedback is used, it is necessary to maintain the level ratio between the playback signal and the feedback signal constant. However, the level of the playback signal fluctuates greatly with tape output differences and variations in head-to-tape contact, hence AGC is necessary.

This board is designed so that the rising AGC time constant is made short and the falling time constant long. This enables variations of head-to-tape contact area to be followed but prevents continuous "0" or "1" data from being followed.

(D) Dropout Detection and Data Output (RF-15 Board)

The output data from the zero-cross detection circuit is converted into an ECL differential signal and output.

When the playback signal falls below a certain level, the dropout detection circuit judges that a dropout has occurred, and makes both differential outputs HIGH (same phase).

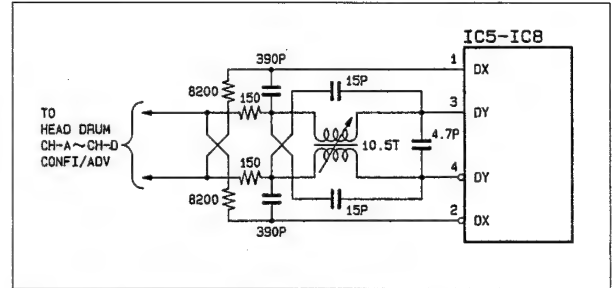

Fig. 3-2-2. Low-pass Filter (RF-15 Board)

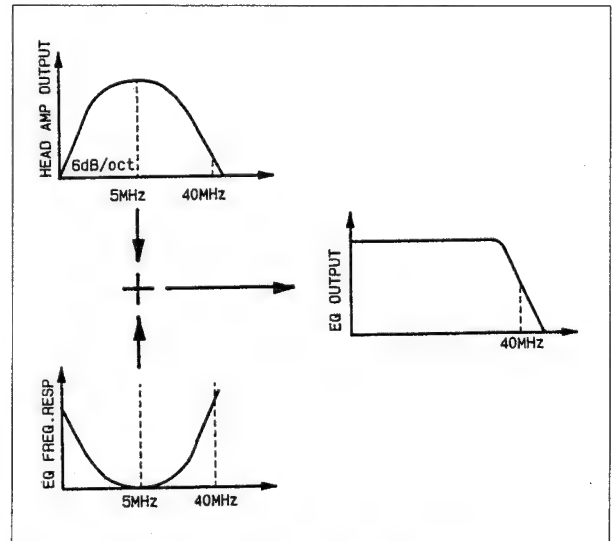

Fig. 3-2-3. Frequency Equalizer (RF-15 Board)

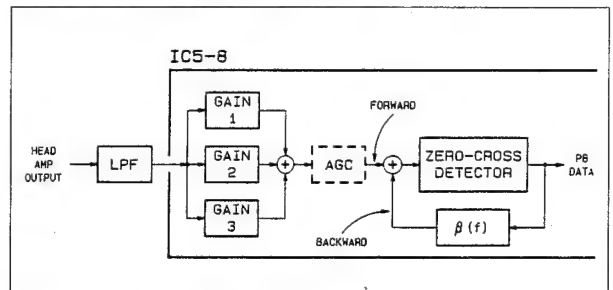

Fig. 3-2-4. AGC (RF-15 Board)

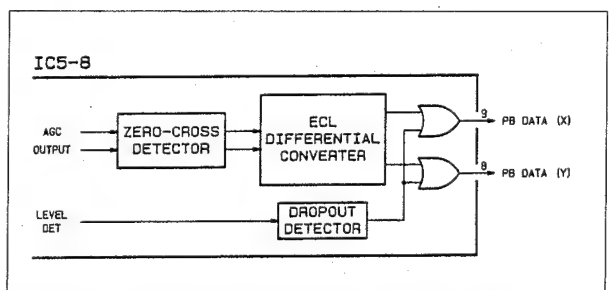

Fig. 3-2-5. Dropout Detection/Data Output Circuit (RF-15 Board)

4-3-3. ADV/CONFI Switching Signal Generator (RF-15 Board)

The playback equalizer (IC5, 6, 7, 8) has two sets of frequency equalization parameters (see 4-3-2.(B)), for the ADV head and the CONFI head, respectively. These parameters can be switched over according to the status of the HSEL signal supplied to pin 18 of each IC.

The parameter switching signal (HSEL) is generated by a monostable multivibrator IC9 and IC10. This signal is based on the PG PULSE supplied from the CD-35 board. Two kinds of pulses are generated to enable the A channel and B channel to be switched simultaneously with the C channel and D channel by adjusting the output timing of the pulses.

4-3-4. Envelope Output Voltage Converter Circuit (IC12/RF-15 Board)

The envelope output (pin 19) from the playback equalizer is a current output which is proportional to the playback envelope level. It is necessary, however, to pass it through a buffer amplifier because of the relationship with the TR-40 board on the receiving side.

This circuit also performs level adjustment independently on each of the CONFI and ADV portions of envelope when the AGC is ON.

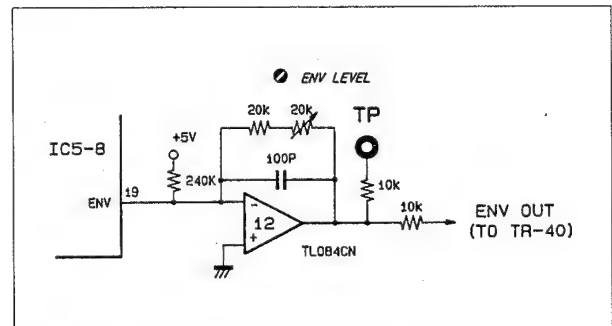

Fig. 3-4-1. I/V Converter Circuit (RF-15 Board)

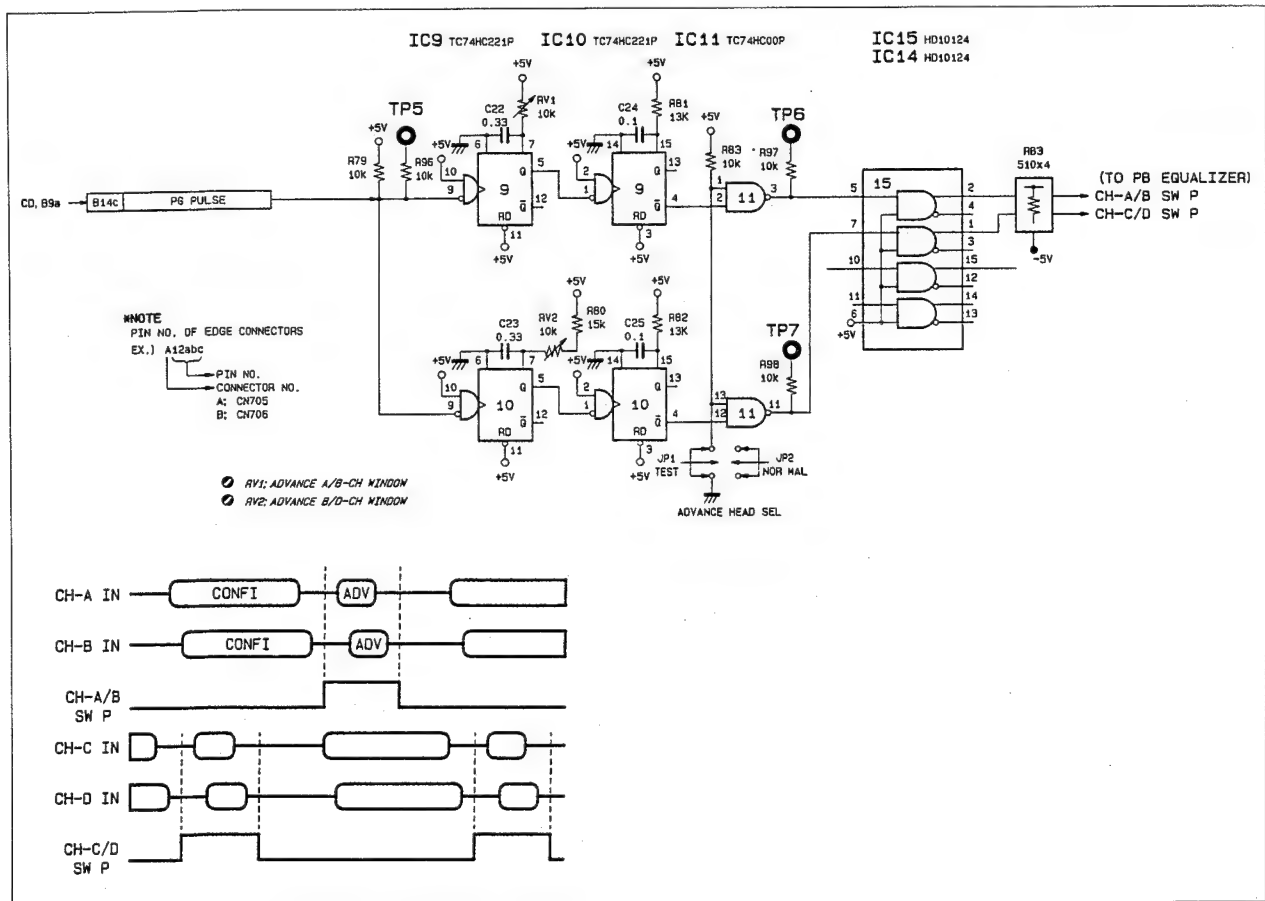

Fig. 3-3-1. ADV/CONFI Switching Signal (RF-15 Board)

4-4. SERVO SYSTEM

4-4-1. Outline of Servo System

The servo system of the DVR-1000 consists of the following boards.

SP-01 board:

HOST CPU
Reference signal generator
Drum/capstan/reel servo
Recording/playback system control circuit
NOVRAM/HOURS METER control circuit

CD-35 board:

Drum/capstan servo
CTL generator/detector

RS-32 board:

SUB CPU
Reel motor servo
Reference voltage generator
Sensor interface

MD-43 board:

Motor driver

Fig. 4-4-1. shows the block diagram of the servo system.

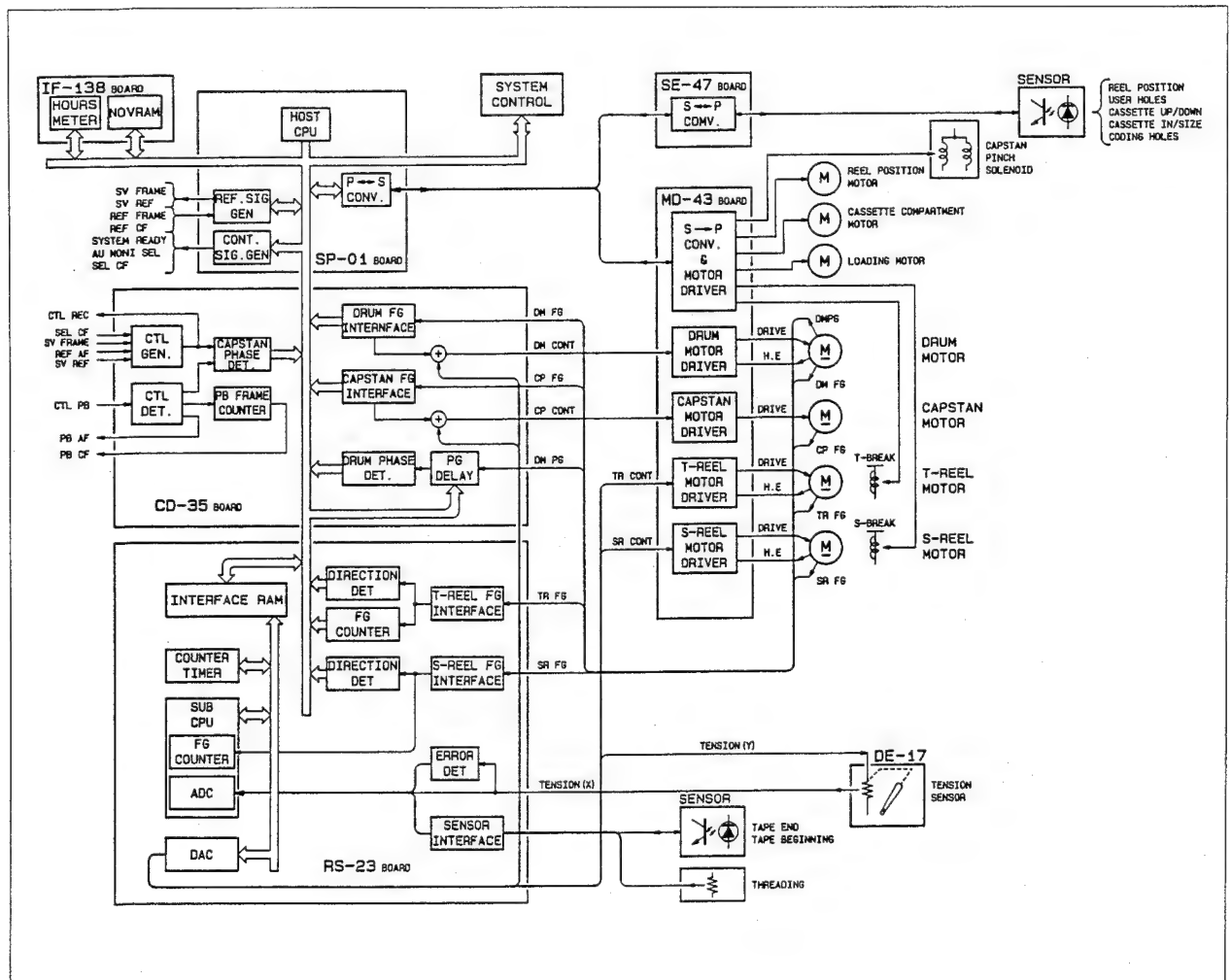

Fig. 4-4-1. Block Diagram of Servo System

(A) SP-01 Board

The SP-01 board consists of the CPU (μ PD70108), its peripheral circuits, and a reference signal generator. It controls the entire tape transport. Control of the RF signal system and the audio (CUE, CTL and TC) signal system, and interfacing between the various sensors in the tape transport, take place via a serial bus.

The SP-01 board controls the speed of the drum, capstan and reel motor using software. This board also controls the NOVRAM and HOURS METER on the IF-138 board.

The reference signal generator outputs the various necessary reference signals to the system control system and the servo system.

(B) CD-35 Board

The CD-35 board consists of a drum and capstan servo circuit and also a CTL generator/detector.

The drum/capstan servo circuit converts the FG pulses from each motor into pulses, which are used to sense the rotational direction and speed of each motor, and then sends them to the CPU. At the same time, it outputs the motor control signals to the MD-43 board.

The CTL generator creates the recording CTL pulses from the frame pulses, audio frame pulses, color frame pulses and servo reference pulses, and outputs it to the AE-05 board.

The CTL detector detects the playback CTL signal sent from the AE-05 board, then separates it into PB AF, PB CF, and PB FR signals, and outputs these signals.

(C) RS-23 Board

The RS-23 board consists of the SUB CPU, reel servo and sensor interface circuit.

The SUB CPU uses a μ PD78C10 containing an A/D converter. This built-in A/D converter is used to input data from the tension sensor and tape beginning/top sensor, and also FG duty data. The D/A converter in the RS-23 board outputs control signals for the motors and plungers.

The reel servo circuit converts the FG signals from the T reel and S reel motors into pulses, and from these pulses senses the rotational direction and speed of the reel motors.

(D) MD-43 Board

The MD-43 board supplies power to the motors and plungers on the tape transport, in accordance with control signals from the SP-01 board, RS-23 board and CD-35 board.

(E) SE-47 Board and Sensors

The SE-47 board integrates the data output from each sensor in the DVR-1000, then sends it to the SP-01 board as serial data. The tension sensor and tape end/beginning sensors are controlled directly by the RS-23 board.

(F) IF-138 Board

The IF-138 board is an interface board on which are mounted the NOVRAM and HOURS METER. These devices are connected to the HOST CPU in the SP-01 board, and are controlled by the SP-01 board.

No further description of the IF-138 board is given in this section. For details of the NOVRAM and HOURS METER, see section 4-7. "Interface".

4-4-2. SP-01 Board

The SP-01 board consists of the HOST CPU (ICB18: μ PD70108), the peripheral circuits of the CPU, and the reference signal generator. It controls the entire tape transport (TTP). This board also performs the following control using software.

- Speed control of the drum and capstan motor
- Reel servo
- Cassette tape loading/unloading control
- Longitudinal time code control (AE-05 board)
- CTL control (AE-05 board)
- CUE control (AE-05 board)
- RF recording/playback control (RF-15 board)
- NOV RAM (Non-volatile memory) control (IF-138 board)
- HOURS meter control (IF-138 board)

1. HOST CPU (ICB18/SP-01 Board)

The HOST CPU ICB18 uses a μ PD70108 (V20) because of the hardware structure and the processing capacity. The external bus of the CPU is 8 bits, however internal processing takes place in 16-bit units. The operating clock of the CPU is 7.37 MHz.

The CPU system consists of ROM-0 (ICB13), ROM-1 (ICB12), a RAM (ICB10), TCU (ICD1 and D2), parallel I/O (ICD5 and D6), serial I/O (ICC7 to C12, and D7 to D12), and an interrupt controller (ICB15).

Fig. 4-2-1. shows the memory map of the SP-01 board. All devices are located in the same segment in order to avoid unnecessary segment jumps. Also, the vector area and the reset start address (FFFF_H) of the CPU are located in ROM-0. The I/O for the external interface is located on the memory map. It is arranged so that a command group that is more powerful than an I/O command can be used.

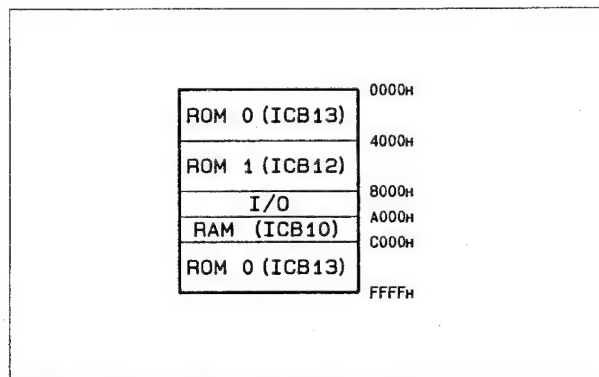

Fig. 4-2-1. Memory Map (SP-01 Board)

2. Address Decoder (ICA23, B21, D15, D16/SP-01 Board)

As can be seen from Fig.4-2-1, the memory address is divided every 4000_H . The address decoding is performed by ICB21. The first half of the area between 8000_H and $BFFF_H$ on the memory map is assigned to the I/O, and the latter half to the RAM. The output from pin 6 of ICB21 and the inverted address A13 are passed through a NAND gate to create the CE signal (pin 20: $A000_H$ to $BFFF_H$) of RAM ICB10.

In the I/O area, the I/O ports on the RD-23 and CD-35 boards and the serial I/O and TCU in the SP-01 board are assigned. In ICA23, addresses A11 to A15 are decoded, and the area between 8000_H and $BFFF_H$ are divided every 800_H . The area between 8000_H and $87FF_H$ is assigned to the interface of another board, the area between 9000_H and $97FF_H$ is assigned to the I/O in the SP-01 board, and the area between 9800_H and $9FFF_H$ is assigned to the interrupt controller. The area between 8800_H and $8FFF_H$ is not used.

In ICD15 and D16, the area between 8000_H and $87FF_H$ is further divided every 100_H , and assigned to the respective boards.

The area between 9000_H and $97FF_H$ is decoded by ICB21. The serial I/O and parallel I/O is assigned to the area between 9000_H and $91FF_H$, TCU-0 (ICD3) to the area between 9200_H and $93FF_H$, and TCU-1 (ICD1) to the area between 9400_H and $95FF_H$.

3. Address Separation Latch (ICB17, D13/SP-01 Board)

The data bus AD0 to AD7 of the CPU (μ PD70108) is shared by data and addresses. The addresses to be used in the SP-01 board are latched from this bus and separated by ICB17.

The address signals that are supplied to the external boards, such as the RS-23 board and the CD-35 board, are latched in a latch which is separate from the address separating latch used in the SP-01 board, and sent to the respective boards. This is because there is a possibility of a delay occurring due to the bus buffer, or a bus capacity problem arising, when addresses and data are separated using the ALE signal outside the SP-01 board, and also to prevent trouble that occurs outside the SP-01 board from affecting the board.

4. Data Bus Buffer (ICC17, D12, D14/SP-01 Board)

ICC17 is used as a data bus buffer for the RAM and ROM in the SP-01 board, ICD12 for the I/O in the board, and ICD14 for the external boards.

If the direction of transmission through these data bus buffers is changed over using an RD signal, the CPU side data bus and the I/O side data bus will collide with each other, although only for a short period. In order to prevent this, the RD signal is widened by $1/2$ clock in ICB13 and the resulting signal used as the bus buffer transmission direction changeover signal.

5. Control Bus (ICC12, C13/SP-01 Board)

CX23026 which is used in the serial I/O (ICC7 to C10, and D7 to D11) does not have a chip select terminal. Consequently, in order to access it, it is necessary to decode the RD signal and WR signal output from the CPU and then supply the resulting signals to the respective ICs. The RD signal is decoded by ICC12, and the WR signal by ICC13. Like the serial I/O, the parallel I/O (ICC1, D5 and D6) use the decoded outputs from ICC12 and C13.

To access the I/O of the external boards as well, the RD signal and WR signal are decoded and output, and the resulting signals used without further processing as control signals for the data bus buffers at the respective boards.

6. ROM (ICB12, B13/SP-01 Board)

The area between $C000_H$ and $FFFF_H$, which includes the start address of the CPU, is assigned to the upper 16 Kbytes of ROM-0 (ICB13).

The area between 0000_H and $3FFF_H$ is assigned to the lower 16 Kbytes.

The area between 4000_H and $7FFF_H$ is located in ROM-1 (ICB12).

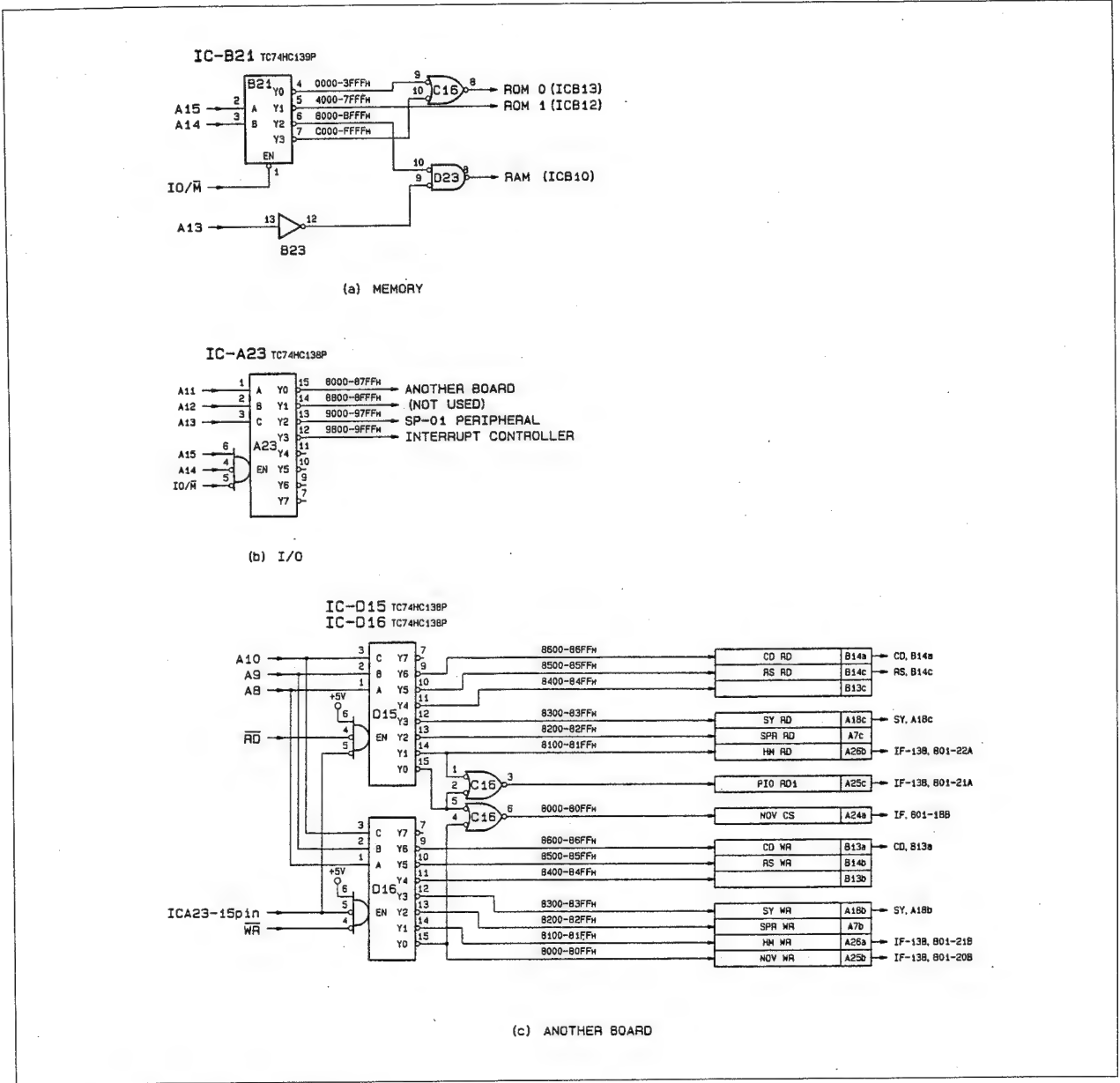

Fig. 4-2-2. Address Decoder (SP-01 Board)

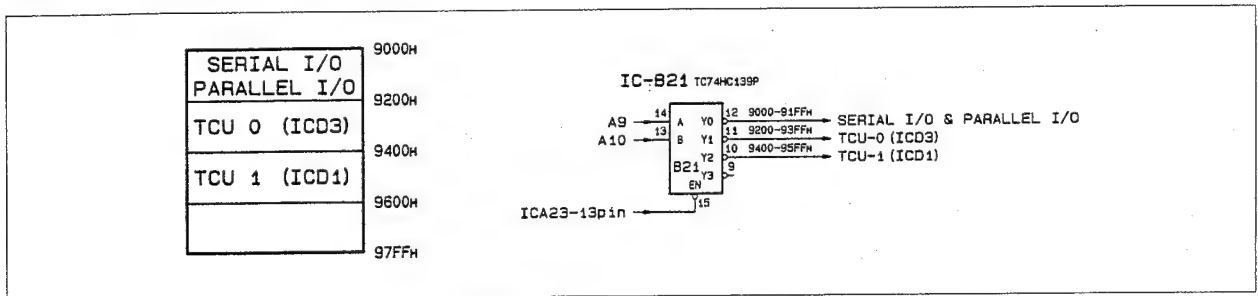

Fig. 4-2-3. Memory Map of I/O Area (SP-01 Board)

7. RAM (ICB10/SP-01 Board)

The RAM (ICB10) is assigned to the area between A000_H and BFFF_H of the memory map. When the system is started, the data in the NOVRAM is transferred to the area between A800_H and A8FF_H. The MAIN CPU in the SP-01 board processes data in the control system and the servo system. To this end, a work area is provided in the RAM. The area between B000_H and BFFF_H is for self-diagnosis.

The data in the RAM, ICB10, is backed up by capacitor C9 in order to preserve the VTR status and data after the power is switched OFF. Also, POP signals from the power supply section are supplied to terminal CS2 (pin 26) of RAM ICB10, in order to protect the data when the power is switched ON or OFF. These functions are intended to keep a history of the data in the system even if the system runs out of control or the power is cut off. At present, however, data backup software is not supported.

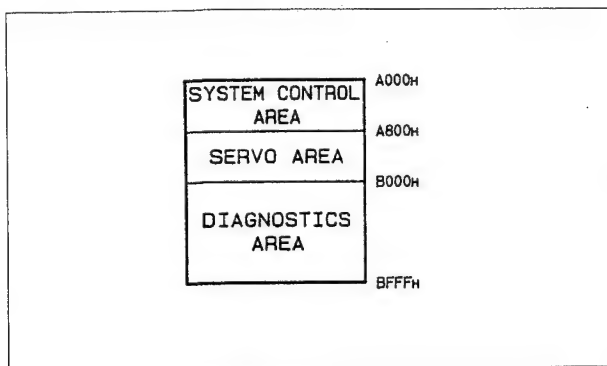

Fig. 4-2-4. RAM (SP-01 Board)

8. External I/O Area (SP-01 Board)

The area between 8000_H and 8FFF_H in the memory map is assigned to the interface between the SP-01 board and the external boards. The NOVRAM in the IF-138 board is assigned to the area between 8000_H and 80FF_H. Servo system adjustment data and VTR operating mode data are memorized in the NOVRAM. In order to rewrite the data in the NOVRAM, it is necessary to execute the "NVW" command in the checker menu on the control panel and then press the NV WR switch S2 on the SP-01 board. This is to prevent data from being erased in the event of a runaway or a malfunction of the CPU. When the system is started, the NOVRAM data is transferred to addresses A800_H to A8FF_H of RAM ICB10 on the SP-01 board. Normally, the CPU refers to the data on the RAM and processes it.

HOURS METER on the IF-138 board is assigned to addresses 8100_H to 81FF_H. Here, data such as the operating hours of the VTR, the drum rotating hours, the tape running hours and the number of tape loading are managed.

Addresses 8300_H to 83FF_H are assigned to the port which communicates with the SY-69 board, 8500_H to 85FF_H to the port which communicates with the RS-23 board, and 8600_H to 86FF_H to the port which communicates with the CD-35 board. Communication with the SY-69 board takes place via the FIFO memory, ICC8, C9, D8 and D10, on the SY-69 board. The RS-23 board has a SUB CPU which changes over the buses using interrupt signal CPU INTR (V/6) and accesses the devices in the RS-23 board.

There is a plurality of devices on the CD-35 board and RS-23 board that are accessed, hence RD, WR and addresses A0 to A7 are supplied from the SP-01 board, and are decoded in the respective boards.

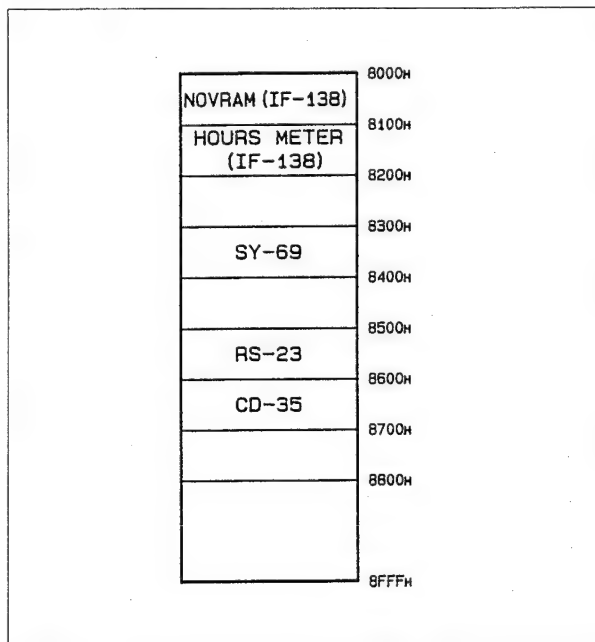

Fig. 4-2-5. External I/O Area (SP-01 Board)

9. Serial Interface (ICC7 to C10, D7 to D11/SP-01 Board)

The serial interface I/O ports are assigned to addresses 9000_H to 91FF_H. Serial data communication takes place between the SP-01 board and the AE-05/SE-47/MD-43/TR-40/RF-15 boards. These boards constitute the signal processing system which is sensitive to noise from the CPU bus. Serial data communication is performed in order to simplify the routing of the harness.

A Sony CX23026 is used in the serial I/O (ICC7 to C10 and D7 to D11). This IC has a 16-bit shift register which functions as a receiver when the SP terminal (pin 9) is "HIGH" level, or as a transmitter when SP terminal is "LOW" level. Parallel data is input and output in 8-bit units. The upper 8 bits (U/L: HIGH) or lower 8 bits (U/L: LOW) are selected by the U/L terminal (pin 10). The communication timing in the case where two CX23026 are used is as shown in Fig. 4-2-6.. At the sending side, when the XINT terminal (pin 13) is "LOW", data transfer starts at the falling edge of the clock (CK: pin 16). At the receiving side, data is taken in at the rising edge of the clock.

Fig. 4-2-7. shows the timing generator for serial data communication. The H/L SEL signal output from pin 11 of ICB6 is supplied to IC11, and is used as an upper byte/lower byte changeover signal. CX23026 inverts the clock supplied to ICB6 so that data starts to be taken in at the rising edge of the clock, SIF CK, and also maintains the SEL signal in a stable condition while data is being taken in. The strobe signal, SIO STB, output from pin 8 of ICB7 must be "LOW" at the falling edge

of the clock, SIF CK. The carry output, CO (pin 15), of ICB6 is latched by ICB7 and output.

The recording equalizer (IC1 to 4) and the playback equalizer (IC5 to 8) in the RF-15 board have serial data receiving sections. The receiving timing of these IC data is different to that of CX23026, hence the data are delayed by inverter ICB8. Table 4-2-1. shows the contents of each serial I/O.

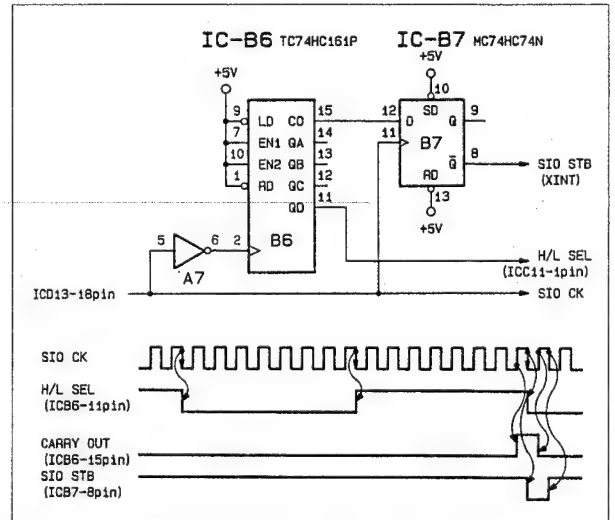

Fig. 4-2-7. Timing Generator Circuit (SP-01 Board)

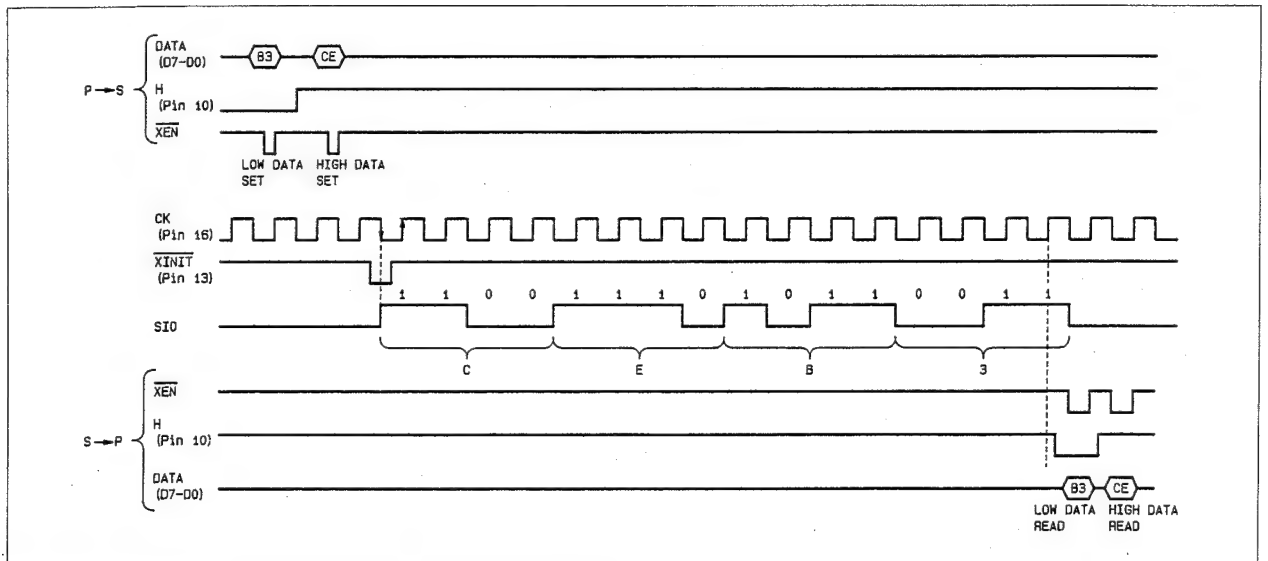

Fig. 4-2-6. Serial I/O Timing Chart (CX-23026/SP-01 Board)

| I/O | | ADDRESS | BOARD | BIT 7 | BIT 6 | BIT 5 | BIT 4 | BIT 3 | BIT 2 | BIT 1 | BIT 0 |
|---------|---|---------|-------|---------------|---------------|-------------|-----------------|-----------------------------------|-----------------|----------|---------------|
| SO0 | L | 9100 H | MD-43 | | DRUM F/R | T-BRAKE | S-BRAKE | RL POSI/CC/LD MOTOR & PINCH ※1 | | | |
| (ICD7) | H | 9101 H | SE-47 | | | CAS. LAMP | OPERATE | REMOTE | CASSETTE LOAD | T REV | T FWD |
| SO1 | L | 9102 H | AE-05 | AUX MONI | AUX PB | AUX ATT | AUX REC | AUX E/P | AUX REC | AX IN S2 | AX IN S1 |
| (ICD8) | H | 9103 H | AE-05 | FULL ERASE | TC ERASE | AUX ERASE | CTL REC | NORMAL FORWARD | TC REC | TC LIN | TC INP |
| SO2 | L | 9104 H | AE-05 | CIN 2 | CIN 1 | TC RLY | AX RLY | AUX MUTE | TC REC | CHK STN | OSC STN |
| (ICD9) | H | 9105 H | AE-05 | | | | TC RLY | METER | FULL ERASE | TC ERASE | AUX ERASE |
| SO3 | L | 9106 H | RF-15 | | | | | | | | |
| (ICD10) | H | 9107 H | | | | | | | | | |
| SO4 | L | 9108 H | | | | | | | | | |
| (ICD11) | H | 9109 H | TR-40 | | | | CUE IN MIC/LINE | WFM SELECT ※3 | | | |
| SI0 | L | 9100 H | SE-47 | CASSETTE IN | CASSETTE SIZE | CASSETTE UP | CASSETTE DOWN | REEL POSITION M | REEL POSITION L | EJECT | USER CENTER M |
| (ICC7) | H | 9101 H | SE-47 | USER CENTER L | USER S-REEL | USER T-REEL | REC INH | TAPE THICK 1 | TAPE THICK 2 | TAPE HC1 | TAPE HC2 |
| SI1 | L | 9102 H | | | | | | | | | |
| (ICC8) | H | 9103 H | | | | | | | | | |
| SI2 | L | 9104 H | AE-05 | | | | OSC CHK | PB CT CHK | PB CT CHK | TC LN HI | TC LN LOW |
| (ICC9) | H | 9105 H | | | | | | | | | |
| SI3 | L | 9106 H | | | | | | | | | |
| (ICC10) | H | 9107 H | | | | | | | | | |

※1

| BIT 3 | BIT 2 | |
|-------|-------|------------------|
| 0 | 0 | Reel Shift Motor |
| 0 | 0 | CC Motor |
| 1 | 1 | Threading Motor |
| 1 | 1 | Pinch Motor |

※2

| BIT 1 | BIT 0 | |
|-------|-------|-----------------------------|
| 0 | 0 | Open |
| 0 | 1 | Larger, Thread |
| 1 | 0 | Smaller, Unthread, Pinch on |
| 1 | 1 | Short, Pinch off |

※3

| BIT 3 | BIT 2 | BIT 1 | |
|-------|-------|-------|-----------|
| 0 | 0 | 0 | CH-A env. |
| 0 | 0 | 1 | CH-B env. |
| 0 | 1 | 0 | CH-C env. |
| 0 | 1 | 1 | CH-D env. |
| 1 | x | x | CTL |

CC MOTOR; CASSETTE COMPARTMENT MOTOR

0; LOW LEVEL

Table 4-2-1. Contents of Serial I/O (SP-01 Board)

1; HIGH LEVEL

x; DONT CARE

10. Parallel I/O (SP-01 Board)

The parallel I/O in the SP-01 board is assigned to addresses 910A_H to 910F_H. ICD1, C2 and D5 constitute the input port, and ICC3 and D6 constitute the output port. SYSTEM RESET pulses are supplied to the output port. During the period from when the power is switched ON or the system reset, until the initial program is executed, all outputs are set to "LOW" level.

Table 4-2-2. shows the contents of each port.

●**SYSTEM HOLD (O PORT: BIT-2/910A_H)**

This signal turns OFF the power supplied to the motor in the tape transport. If the VTR is in one of the following statuses, the output becomes high impedance, and the supply of power to the motor is cut off.

- (a) When the output port of the SP-01 board is "HIGH" level
- (b) When the RS HOLD CONT signal from the RS-23 board is "HIGH" level
- (c) When the BOARD SENSE signal is "HIGH" level (when one of the RS-23/CD-35/SY-69 boards is not installed)
- (d) When the MOTOR ALL OFF switch S3/SP-01 is at "HOLD".

●**SYSTEM READY (O PORT: BIT-5/910A_H)**

This signal becomes "LOW" level when the system is built-up. When the system is in a READY status, the board terminal output becomes high impedance.

●**NOVRAM STORE (O PORT: BIT-3/910A_H)**

This signal transfers data in the RAM section of the NOVRAM (IC5, 6/IF-139) to the non-volatile section. The output from pin 6 of ICC3/SP-01 is passed through a NAND gate, consisting of ICB5, with the status of the NVWR switch S2, and is output only when the NVWR switch is pressed. If the system is reset, the output becomes "H" in order to prevent a malfunction. If the power is switched ON, the output becomes "H" along with the supply of power.

●**NOVRAM RECALL (O PORT: BIT-4/910A_H)**

This signal transfers data in the non-volatile section of the NOVRAM (IC5, 6/IF-139) to the RAM section. It is also used to protect the NOVRAM data, and is held at "L" level when the power is switched ON or the system reset.

●**CPU RESET signal**

This signal is for resetting the VTR using software. The RESET pulses are output according to the following procedure.

- (1) BIT-1/910A_H (O PORT) is made "H" level.
- (2) BIT-1/910C_H (O PORT) is made "H" level.
- (3) BIT-2/910C_H (O PORT) is made "H" level.

●**AUDIO MONITOR SELECT (O PORT: BIT-5, 6/910C_H)**

This signal is for selecting either the output signal going to the AUDIO MONITOR OUTPUT L/R connector or that going the HEADPHONE connector, on the connector panel.

| PORT | ADDRESS | 910A _H (ICC1/C3) | 910C _H (ICD5/D6) | 910E _H (ICC2/C4) |
|------|---------|-----------------------------|-----------------------------|------------------------------------|
| IN | BIT 7 | SP-01 BOARD HARD VERSION | EJECT SW | |
| | BIT 6 | | TRACKING CONT FIX | REF CF |
| | BIT 5 | | LOCAL SELECT | SV FRAME |
| | BIT 4 | | OVERHEAT | IN FRAME |
| | BIT 3 | | HOLD CONTROL | PHASE MEASURE PRESCALER |
| | BIT 2 | | BOARD SENSE 1 | |
| | BIT 1 | | SY OUTPUT READY | |
| | BIT 0 | | SY INPUT READY | |
| OUT | BIT 7 | TP2:SP SPARE OUT | REC MODE | REF FRAME PHASE MEASURE REQUEST |
| | BIT 6 | REC ENABLE | AUDIO MONI R-SEL | |
| | BIT 5 | SYSTEM READY | AUDIO MONI L-SEL | |
| | BIT 4 | NOV RAM RECALL | FRAME SELECT | |
| | BIT 3 | NOV RAM STORE | COLOR FRAME SELECT | |
| | BIT 2 | SYSTEM HOLD | RESET CLOCK | |
| | BIT 1 | RESET ENABLE | RESET ENABLE | |
| | BIT 0 | TP1:INT TIME MONITOR | SERVO REF SELECT | |

Table 4-2-2. Parallel I/O (SP-01 Board)

11. Interrupt Controller (ICB15/SP-01 Board)

Address 9800_H is used for setting the mode of the interrupt controller (ICB15: μ PD71059 NEC). This IC has eight interrupt terminals. Of these, INTP4 (pin 22: V/6 INT), INTP5 (pin 23: PIO INT) and INTP6 (pin 24: NOV RAM WR) are used in this circuit. At present, AU INT is input to the INTP3 terminal (pin 21), however it is not used.

12. Clock Generator (ICC19/SP-01 Board)

The following timing pulses are output from ICC19 (μ PD7011).

- PIN-12/ICC19: 14.7456 MHz clock
- PIN-10/ICC19: CPU reset pulse
- PIN-8/ICC19: 7.3728 MHz CPU operation clock
- PIN-5/ICC19: READY pulse

In the DVR-1000, the 7.3728 MHz clock is used as a quantizing clock for measuring speed and phase, hence the accuracy of this clock affects the accuracy of the tape speed during recording. In other words, it also affects the format. In order to realize a tape speed sensing accuracy of 0.01%, the accuracy of the clock must be 0.001% or better.

13. Reset Pulses (SP-01 Board)

The CPU will be reset in each of the following cases.

- When the power ON pulses (POP) from the power supply section are high impedance
- When the RESET switch S1 on the SP-01 board was pressed
- When the reset signal from the output port ICD6 was output
 - (a) When a switchover was made between the 525 and 625 systems
 - (b) When the system was restored from the mechanical checker mode on the checker menu

14. RD Pulse Expansion (ICC21/SP-01 Board)

Bus transceivers (ICC17, D12, D14; TC74HC245) are installed between the CPU and the ROM/RAM, and also between each I/O port. When the CPU performs a read operation and also the DIR (pin 1) of the bus transceiver switches over at the rise of the RD pulse, a bus collision occurs, though only for a short period, between the bus transceiver and an external device. This period becomes long if the external device has a slow response.

Consequently, in the ICC21, the rise of the pulse is delayed by 1/2 CPU clock to prevent a bus collision.

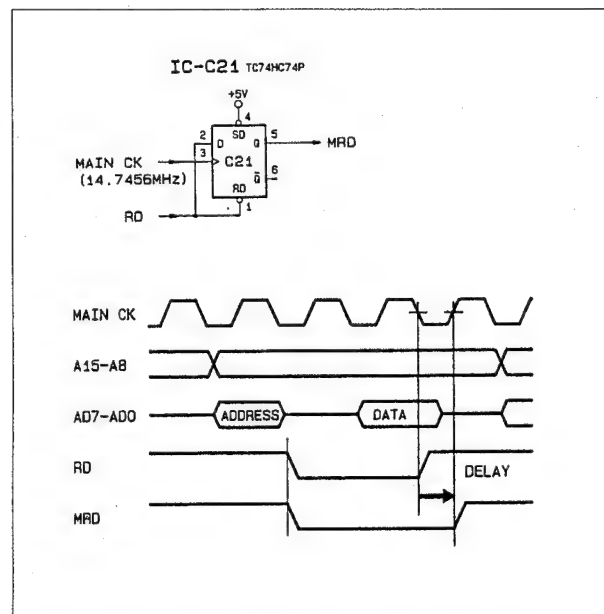

Fig. 4-2-9. RD Pulse Expansion (ICC21/SP-01 Board)

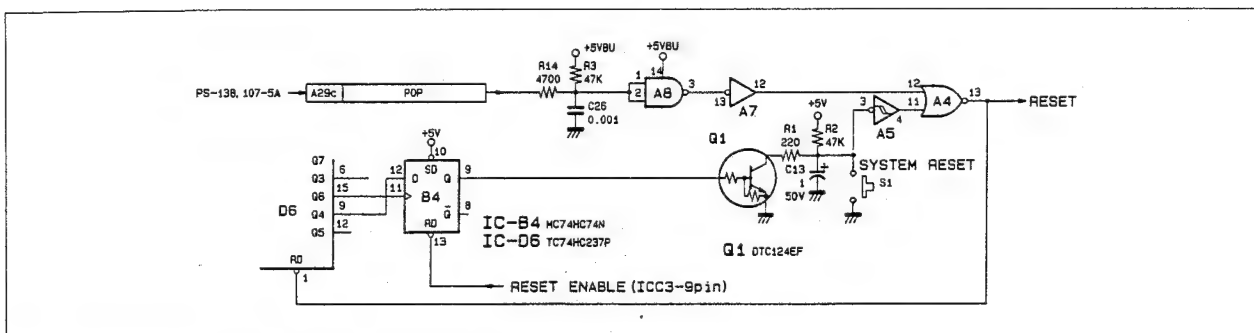

Fig. 4-2-8. RESET Pulse Generator (SP-01 Board)

15. CPU WAIT (IC20/SP-01 Board)

The I/O in the SP-01 board satisfies the read/write timing of the CPU. In the case of the I/O of the other boards, however, the margin of access time may sometimes disappear when an extension board is used. In order to overcome this, a 1-clock WAIT is inserted when accessing an external I/O.

Fig. 4-2-10. shows the standard read time of the CPU. There is an interval of 406 nsec (3/7.373 MHz, A in figure) from the start of a read operation by the CPU until data is taken in. In the case of the ROM and the RAM, addresses A15 and A14 are decoded and input to the CS terminal, then AD7 to AD0 separate the data and addresses using latch ICB17, and input them to A7 to A0. Addresses A15 to A8 are finalized 60 nsec after the fall of T4, and if the delay inserted by the decoder ICB21 is 40 nsec, the CS signal will be output 100 nsec after the fall of T4. The ASTB signal (pin 25) becomes "H" level 50 nsec after the falling edge of T4, and if the delay inserted by the latch ICB17 is 30 nsec, addresses A7 to A0 to the ROM and RAM will become finalized after 80 nsec. Here, the period until the CPU takes in data is 306 nsec (406-100), and if a ROM having an access time of 250 nsec is used, there will be a margin of 56 nsec (306-250).

For an I/O outside the board, however, A7 to A0 and the RD/WR signal are decoded before use, hence the access time is calculated on the basis on the fall of the RD signal. The period from the falling edge of the RD signal until the CPU takes in data is 190 nsec (406-216), and because of the delay of the RD signal buffer ICD20 (30 nsec) and the delay of the decoder ICD15, 16 (40 nsec), the access time of the I/O must be 120 nsec or less. In actual fact, additional delays occurs because of the buffer, etc., on each board. In order to overcome this, the clock WAIT signal is supplied to the CPU when an external I/O is being accessed.

A WAIT signal is supplied to the CPU in the following cases.

- When 8000_H to 8FFF_H is being accessed: I/O interface outside SP-01 board
- When 9000_H to 91FF_H is being accessed: Serial I/O interface

The address signals for these areas are decoded by ICA23, input to the RDY2 terminal (pin 6) of ICC19, and a WAIT applied to the CPU. The ASTB signal from the CPU is latched by the CPU operation clock and input to the RDY1 terminal (pin 4) of ICC19, then a WAIT signal delayed by exactly 1 clock is sent to the CPU.

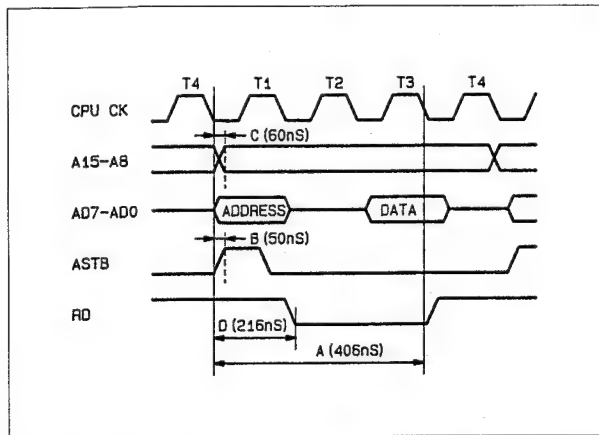

Fig. 4-2-10. CPU Data Read Timing (SP-01 Board)

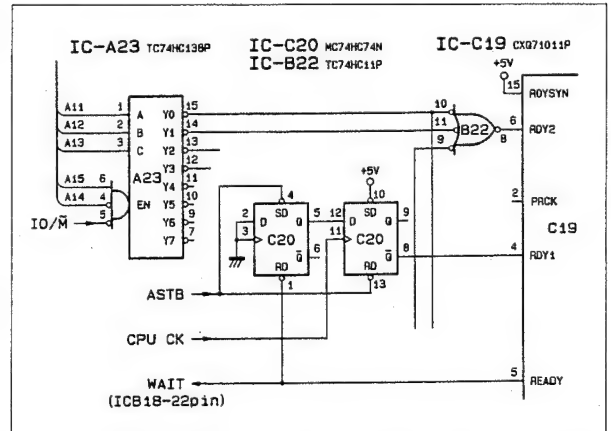

Fig. 4-2-11. WAIT Signal Generator (SP-01 Board)

16. Fault Indication (ICA4, B5, C14/SP-01 Board)

ICA4, B5 and ICC14 monitor the condition of the CPU. If a CPU runaway occurs for some reason or other, they will request an NMI (Nonmaskable interrupt) from the CPU. CPU interrupt processing monitor pulses are input to pin 9 of ICB5. These pulses are generated at a period of V/6 (525/60: 2.8 msec, 625/50: 3.3 msec) if the operation of the CPU is normal. The time constant of the monostable multivibrator, ICC14, is 10 msec. If the CPU is operating normally, the output which is triggered at a period of V/6 (pin 10) is always "H" level, and the WATCH DOG LED D1 (green) does not light. If the CPU is in a SYSTEM HOLD status or a RESET status, the SYSTEM HOLD signal (pin 15/ICC3) becomes "L" level, and the 7.37 MHz clock which is input to pin 9 of ICA4 becomes a trigger pulse, hence D1 does not light. For conditions other than the above, the output from pin 10 of ICC14 becomes "L" level, D1 lights, the output of pin 9 of ICC14 becomes "H" level, and an NMI request is sent to the CPU.

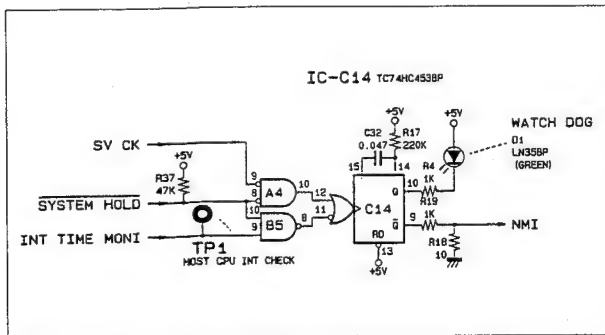

Fig. 4-2-12. NMI Pulse Generator (SP-01 Board)

17. Reference Signal Generator (SP-01 Board)

The 7.3728 MHz clock generated by the clock generator is used to output the various reference signals that are necessary for the system control system and the servo system. These reference signals are also used as quantizing clocks for the servo CPU, hence it is necessary to avoid abrupt phase shifts. Consequently, in order to maintain continuity, the reference signal generator is synchronized without any abrupt phase shift, even if the reference signal is input from the DVPC-1000. The reference signal generator has the following three systems. Fig. 4-2-13. shows the block diagram of the signal generator.

- SIO CK, V/6 and frame signal system
- SV REF signal system (for drum, capstan, and servo system)
- Frame phase measuring system

(A) SIO CK, V/6 and FRAME Signal System (SP-01 Board)

This system generates the following signals:

- SY FRAME: 29.97 Hz (525/60), 25 Hz (625/50)
- V/6, SIO STRB: FRAME x 12
- SIO CK: FRAME x 196

First, SIO CK is generated from the 7.3728 MHz clock. Next, it is frequency-divided by 1/16 to generate V/6 and SIO STRB. It is then further frequency-divided by 1/12 to generate SY FRAME.

If the 7.3728 MHz clock is simply frequency-divided to produce SIO CK, jitter of the FRAME signal will become large. To prevent this, a certain percentage of the clock pulses applied to the frequency divider ICD3 (counter No.1) are removed, resulting in SIO CK. The clock pulses for this are removed by ICA3 and A4. The window pulses for this are generated by counter No.2 of ICD3. The window is opened once to V by the CO output (pin 15) of ICC23. Its width is assigned to ICD3 from the CPU. When the output from pin 17 of ICD3 is "L" level, a certain percentage of the clock pulses are removed. SIO CK, which is obtained by frequency division, is output from pin 13 of ICD3. This signal is frequency-divided by 1/16 and the V/6 signal generated. Also, the pulse width and timing are varied by ICB7, resulting in the SIO STRB signal. This signal is frequency-divided by 1/6 by ICC23, then additionally frequency-divided by 1/2 by ICC22, resulting in the SY FRAME signal.

The SY FRAME signal is differentiated by ICB4 and B5, then sent to the phase comparator circuit, ICC5, and also the SV REF generator, ICD1.

(B) Servo Reference Signal System (SP-01 Board)

Like SIO CK, if the servo reference signal (SV REF) is simply frequency-divided, jitter will occur, hence a certain percentage of the pulses going to the frequency-divider ICD1 (counter No.1) are removed.

The method of removing the clock pulses is the same as for the case of SIO CK. The pulses are removed by ICA2 and A4. The window pulses for this are generated by counter No.2 of ICD1. The SV REF signal obtained by frequency division is output from pin 13 of ICD1. This signal is synchronized with the frame pulses by counter No.0 of ICD1, then sent to ICA6. In ICA6, either the SV REF signal which is generated internally or the EXT SV REF signal which is supplied from an external source is selected, and output to the RS-23 board and the CD-35 board. This signal is also used as a trigger signal for the waveform monitor.

(C) Frame Phase Measuring system (SP-01 Board)

The frame signal which is input to this board is supplied to the phase comparator circuit, ICC5, and the input port ICC2. Also, the color frame pulses are supplied to the input port, ICC2, and the CD-35 board.

The phase comparator circuit is provided in order to synchronize the internally generated SY FRAME pulses with frame pulses input from an external source. In an actual circuit, phase comparison is performed by counter No.0 of ICD3 and ICC4 and C5. ICC4 functions as the lower four bits of ICD3, permitting measurement at a resolution of about 70nsec. ICC5 is the controller of the measuring system. It outputs pulses from the input REF FRAME signal to the SY FRAME signal when a measuring request signal is output from the CPU.

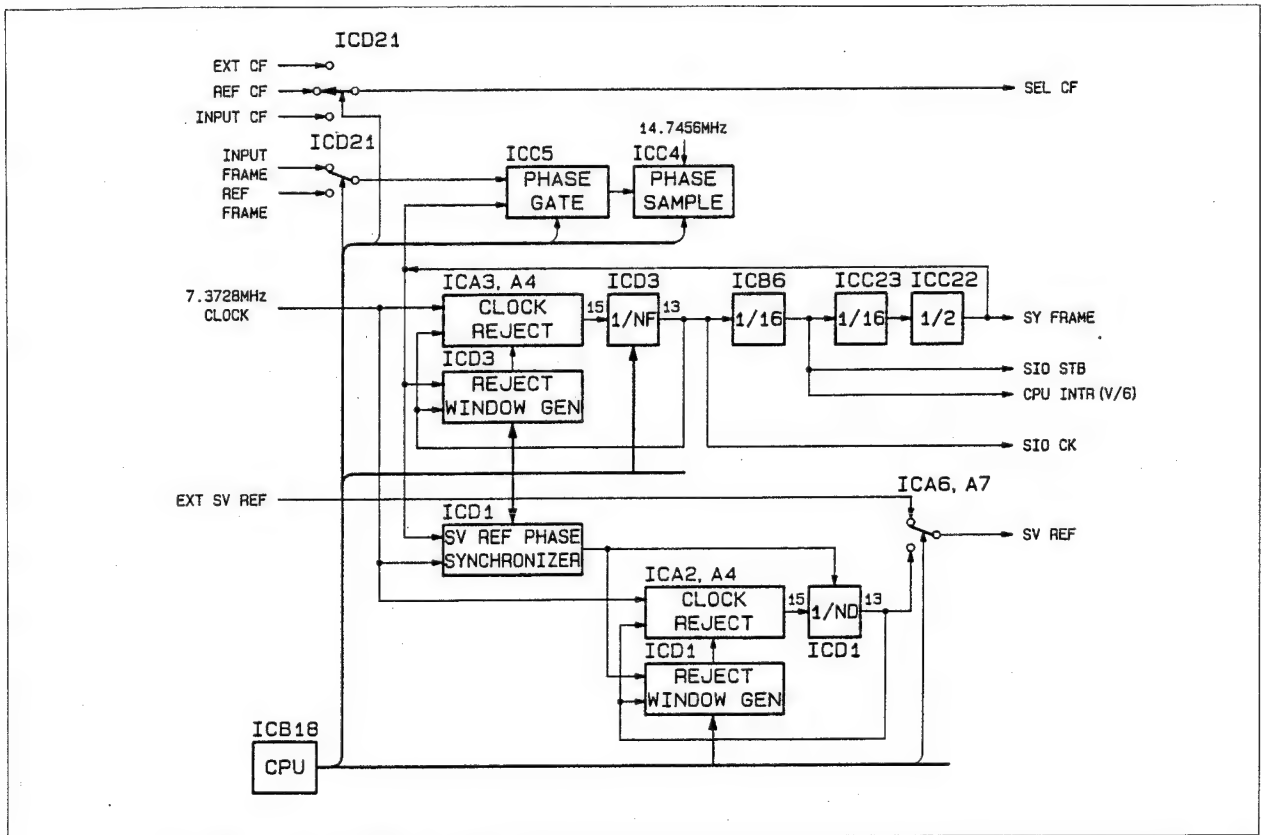

Fig. 4-2-13. Sync Signal Generator (SP-01 Board)

4-4-3. CD-35 Board

The CD-35 board consists of the following circuits.

- Drum servo circuit
- Capstan servo circuit
- CTL generator
- CTL playback circuit

1. Drum Servo System (CD-35 Board)

(A) Generating pulses from drum FG (CD-35 board)

The FG signal which is input to the CD-35 board has a level of about 2.0 V_{p-p}, and a DC offset of between 3.7 and 7.0 V. When this FG signal is being converted into pulses in a comparator, the DC offset causes the duty of the pulse signals to change. It is therefore necessary to remove the DC offset. Because the drum motor rotates at high speed other than when starting and stopping, the DC offset is removed by means of a capacitor. There are 48 pulses per rotation of the drum, and the drum motor rotates at 150rps. Consequently, the frequency of the FG pulses is 7200 (150 x 48) Hz.

Fig. 4-3-1. shows the pulse generator. The DC component of the input FG signal is removed by capacitor C62 (C61). The high pass filter consisting of C62 and R100 (C61 and R101) is set to $f_c = 170$ Hz so that the rotation of the motor can be sensed when it is starting and stopping, and also so that fluctuations in the offset when the motor is starting can be ignored.

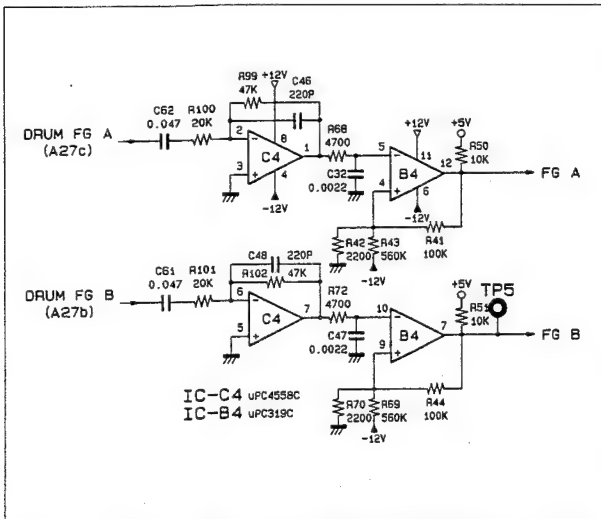

Fig. 4-3-1. Drum FG Interface Circuit (CD-35 Board)

The FG signal from which the DC component has been removed is amplified by the operational amplifier, ICC4, to a level which enables it to be converted into pulses, then unwanted high frequency components are removed by a low-pass filter consisting of C46 and R99 (C48 and R102), and C32 and R68 (C47 and R72). The cutoff frequency of the low-pass filter is set at 15 KHz which is more than twice the pass band.

Hysteresis is applied to the comparator, ICB4, by R4, 41 and R43 (R44, 69, 70). This is to ensure that noise and other disturbances do not prevent the drum stop status from being sensed correctly when the drum stops. The width of the hysteresis is set at 100 mV to ensure that the time difference when the motor is rotating is sensed correctly.

(B) Drum rotational direction sensing (CD-35 board)

The direction of rotation of the drum motor is sensed by ICB6. Fig. 4-3-2. shows the timing chart of ICB6. When the drum motor rotates in the clockwise direction, the A phase (FG-A) is 90° ahead of the B phase (FG-B). This phase difference is used to sense the direction of rotation (DIR1).

The exclusive logical sum, DMEX (pin 15) of FG-A and FG-B is sent to the V-LOOP circuit and used to sense the speed of the drum motor.

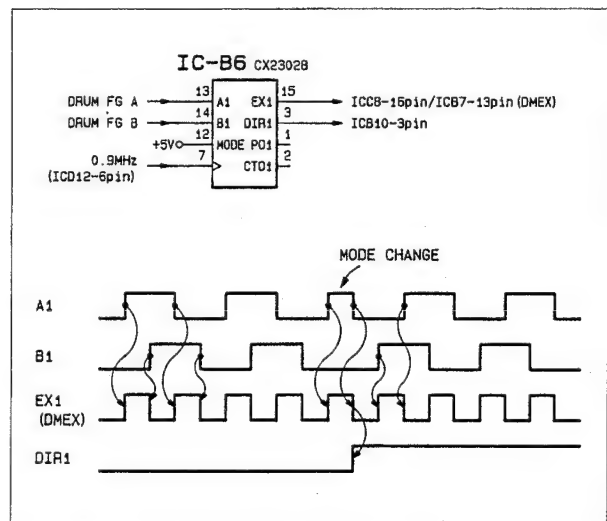

Fig. 4-3-2. Drum Rotational Direction Sensing (CD-35 Board)

(C) Drum motor speed sensing (CD-35 board)

The drum V-LOOP circuit senses the rotational speed of the drum motor from the time difference between the A phase and the B phase of the FG pulses. The pin 15 output (DMEX) of ICB6, which is the exclusive logical sum of the A phase (FG-A) and B phase (FG-B), is used for sensing the rotational speed. Here, the speed of the motor is sensed as the time difference between DMEX and the reference pulses. This time difference is T-V converted and supplied to the drum motor. Fig. 4-3-3. shows the speed sensing circuit. The reference signal for speed sensing is generated in TCU ICC8. ICC8 functions as a mono-multivibrator which outputs negative pulses for exactly the period set by the counter, from the valid edge of the gate pulse, GATE2 (pin 16). The logical sum of OUT2 (pin 17) of TCU ICC8 and DMEX is the speed difference DM. OUT2 of TCU becomes "L" level for the first time when the next clock, CLK2, is input after the valid edge of the gate pulse is input, hence during this period a quantizing error occurs. This circuit senses the time delay from when the effective edge of the gate pulse is input until OUT2 becomes "L", as a speed difference, in order to prevent a quantizing error from occurring.

(D) T-V converter (CD-35 board)

The T-V converter converts the pulse width of the speed difference DM into a voltage. The dual transistor Q1 is used as a constant current source and also as a switching device. It is designed so that the base potential, B2, of Q1 is fixed at +4.9 V by R14 and R15, and the base potential, B1, is +5.9 V when DM is "H" level, or +4.2 V when DM is "L" level. Consequently, when DM is "H" level, current flows through collector C1, and when DM is "L" level, current flows through collector C2. If current flows through collector C2, the emitter potential E of Q1 is +5.5 V, hence Q1 operates as a constant current source of 1.4 mA. The current which flows out from collector C2 passes through diode D2, causing capacitor C14 to charge. Diode D2 clips at +5 V in order to prevent the voltage of C14 from exceeding +5 V. In this circuit, when the potential of capacitor C14 approaches +5 V, the characteristics of diode D2 cause the linearity to fall off. To overcome this, the T-V conversion output is used over the range between 0 and 4 V, and the output at constant speed is set at 2 V.

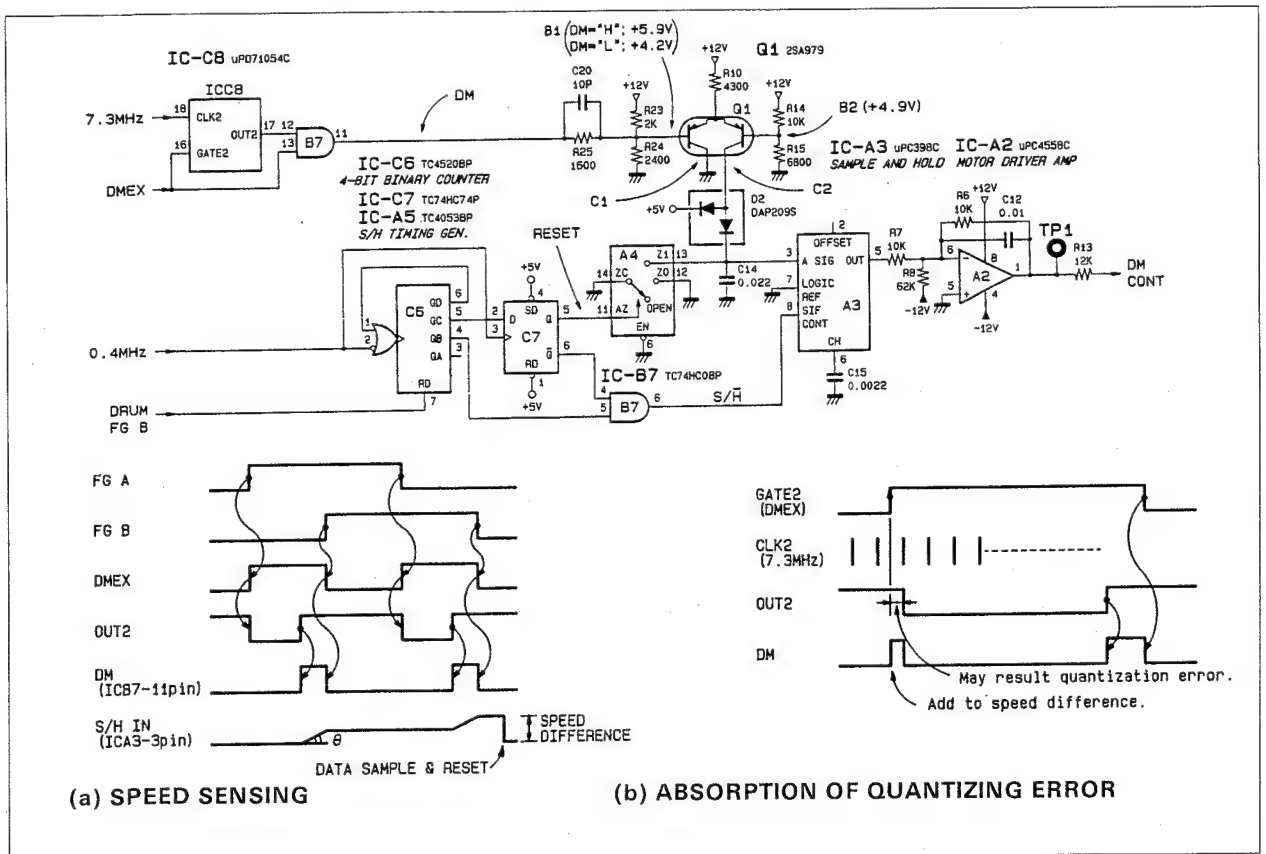

Fig. 4-3-3. Drum Motor Speed Sensing and T-V Conversion (CD-35 Board)

(E) Sample/hold timing generator (CD-35 board)

The reset pulses of capacitor C14 in the T/V converter are generated from the B phase drum FG pulses (FG-B). When FG-B becomes "L" level, the reset (pin 7) of the counter ICC6 is canceled, and ICC6 starts to count. When QB becomes "H" level 1 to 2 clock pulses (2.5 to 5 μ sec) after the counter starts, the output of pin 6 of ICB7 becomes "H" level, and the sample/hold amplifier ICA3 goes into the sample mode. The sampling period is 2 clock pulses (5 μ sec), enabling an adequate charging period to be obtained. Capacitor C14 is reset 1 clock pulse after sampling takes place. The discharge period of the capacitor is 4 clock pulses (10 μ sec).

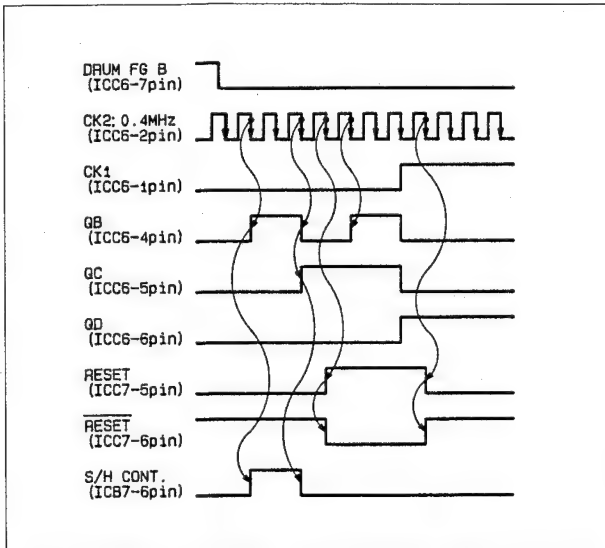

Fig. 4-3-4. Sample/hold Timing (CD-35 Board)

(F) Drum motor drive amplifier (CD-35 board)

The output signal from the sample/hold amplifier ICA3 is speed-compensated by the CPU, then sent to the motor drive amplifier ICA2. The gain of the motor drive amplifier is -1 at the front end, and -39 at the output stage. When the drum motor is starting or stopping, the CPU drives the motor directly via a D/A converter. This select is performed by ICA4. When the CPU is driving the motor directly, the signal which passes through R11 and pin 2/pin 15 of ICA4 is amplified by ICA2 and output. The gain of ICA2 at this time is about 3.

The acceleration characteristics and the deceleration characteristics of the drum motor differ greatly from each other, deceleration taking place more abruptly than acceleration. Consequently, a limiter consisting of ICC2 and D5 is installed to prevent a signal of less than a constant level from being output when V-LOOP is operating. The operating voltage of the limiter is 3.4 V.

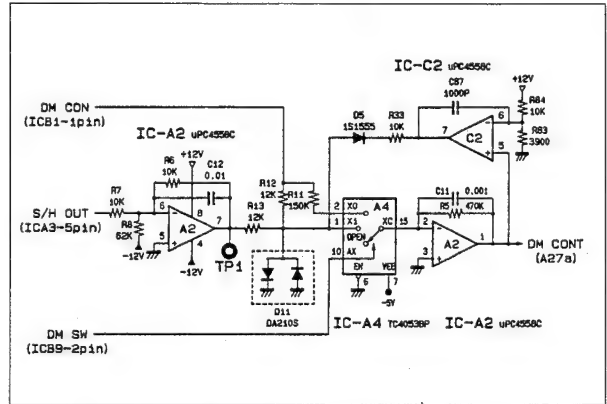

Fig. 4-3-5. Drum Motor Drive Amplifier (CD-35 Board)

(G) PG delay circuit (CD-35 board)

The drum PG pulses are output in advance from the specified position where they are electrically delay-adjusted. The PG pulses supplied from the drum motor are compared in ICD4. Comparator ICD4 has a hysteresis of 0.16 V. The zero-cross position of the PG pulses is the timing point. Consequently, at TP6, the changeover point from "L" level to "H" level is the valid edge. Because the drum PG is generated by a Hall device, jitter is significant, and drum PG is synchronized by the drum FG. Consequently, delay adjustment is divided into coarse adjustment using the drum FG, and fine adjustment using the 7.3 MHz clock. If the drum PG which is input to pin 11 of TCU ICC11 is near the valid edge of the drum FG which input to pin 9, the operation of the counter will become unstable, hence drum lock may sometimes fail to take place. In order to prevent this, the polarity of the drum FG is inverted by ICA14. The delay-adjusted drum PG pulses are output as negative logic pulses from pin 4 of the monostable multivibrator, ICD14. The width of these pulses is 150 nsec. These pulses are also supplied to the RF-15 board and used as the switching pulses of the RF signal.

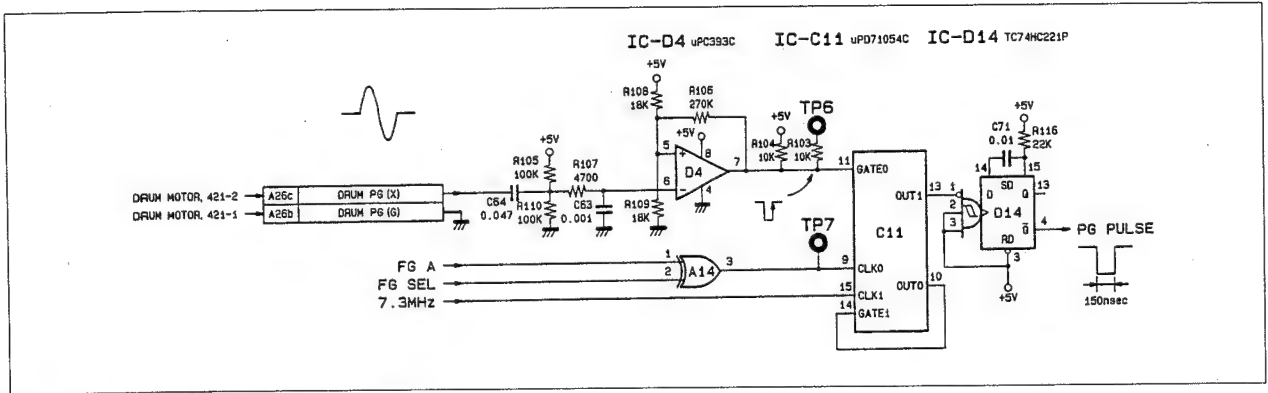

Fig. 4-3-6. PG Delay Circuit (CD-35 Board)

2. Capstan Servo System (CD-35 Board)

(A) Converting capstan FG into pulses (CD-35 board)

The 2.0 V_{p-p} capstan FG signal which has a DC offset of between 5.6 and 9.0 V is input to the CD-35 board. Ninety capstan FG pulses are output for each revolution of the capstan, and the frequency in the PLAY/REC mode is about 1360 Hz.

The capstan motor is used for tape travel over the range of -0.25 to +1 times normal speed. Consequently, it is necessary to accurately sense when the capstan motor stops and also when it is rotating at low speed. Fig. 4-3-8. shows the interface circuit of the capstan FG.

The output of the D/A converter in the RS-23 board is connected to the non-inverting input terminal of the operational amplifier, ICC3. This voltage is adjusted so that the DC offset is zero.

The output of the operational amplifier, ICC3, is used to control the capstan motor at low speed, hence it is sent to the A/D converter via an attenuator. The input range of the A/D converter is between 0 and AV REF (+3.3 V), hence signals between -3.3 and +3.3 V are converted into signals between 0 and +3.3 V in the attenuator. The level of the capstan FG is 2 V_{p-p}, hence the gain of ICC3 is set to 2.35 to prevent the output from exceeding ±3.3 V.

The low-pass filter consisting of C42 and R61 (C44 and R67), and C30 and R60 (C31 and R64) removes unwanted high frequency components from the comparator input. The cutoff frequency of the low-pass filter is 3 KHz. Comparator ICB3 converts capstan FG into pulses. R34, 35 and R36 (39, 40 and 63) apply ±50 mV hysteresis to the comparator. The low-pass filter consisting of R45, R46 and C33 (R47, R48 and C34) is installed to enable the CPU to monitor the duty of the capstan FG pulses.

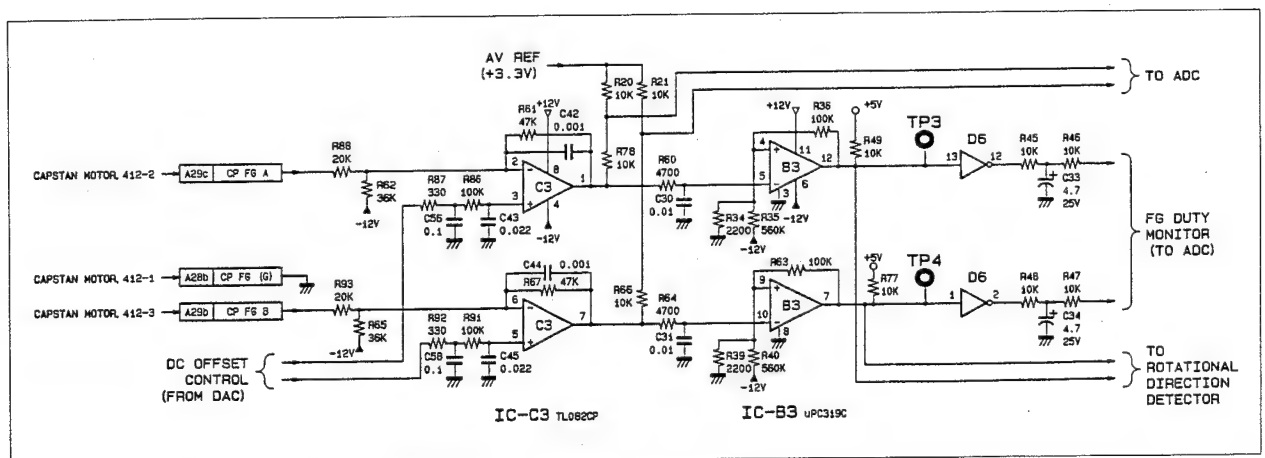

Fig. 4-3-7. Capstan FG Interface (CD-35 Board)

(B) Capstan motor rotation direction sensing (CD-35 board)

Like the drum motor, the direction of rotation of the capstan motor is sensed by ICB6. The direction of rotation is sensed from the difference in phase between the A phase (FG-A) and the B phase (FG-B) of the FG pulses. If the capstan is rotating in the clockwise direction, FG-A is 90° ahead of FG-B. When the tape is traveling in the FWD direction, the capstan rotates in the counterclockwise direction. In order to make the status in the FWD direction the same as that of the other motors, FG-A is input to B2 (pin 11) of ICB6, and FG-B is input to A2 (pin 10) of ICB6.

In addition to sensing the direction of rotation, ICB6 senses the exclusive logical sum of FG-A and FG-B, and also the edges of FG-A and FG-B. The exclusive logical sum output, EX2 (pin 9), of FG-A and FG-B is sent to the V-LOOP circuit. Also, the detected edge, CTO2 (pin 5), is used for phase measurement.

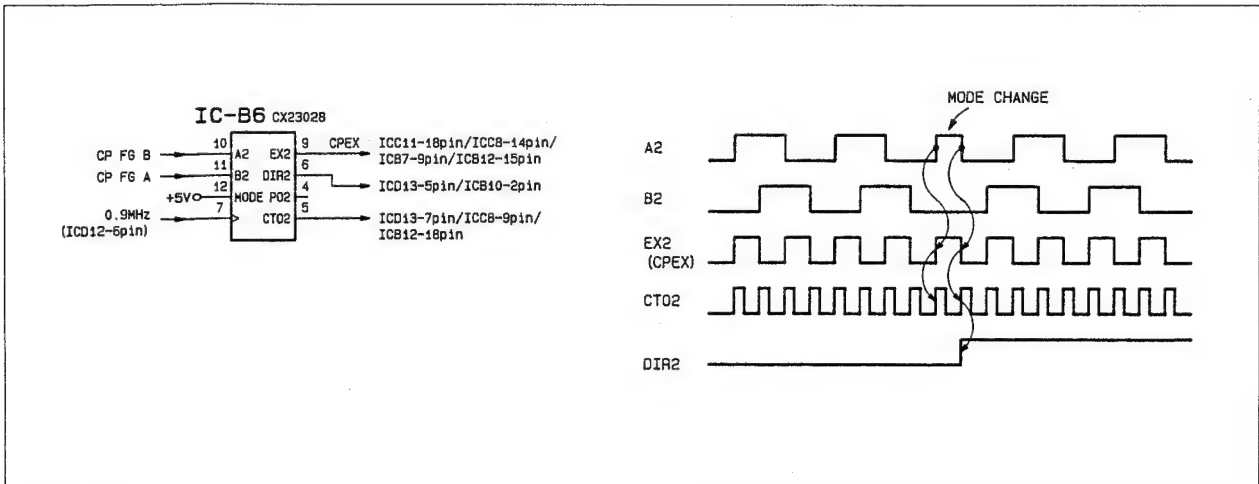

Fig. 4-3-8. Capstan Motor Rotation Direction Sensing (CD-35 Board)

(C) Capstan motor speed sensing (CD-35 board)

In the capstan V-LOOP circuit, the motor speed is sensed from the time difference between FG-A and FG-B, as in the case of the drum V-LOOP circuit. Measurement of speed is performed using the period from the rising edge of FG-B to the rising edge of FG-A, and also the period from the falling edge of FG-B to the falling edge of FG-A. In actual fact, the pulse width of CPEX (pin 9/ICB6), which is the exclusive logical sum of FG-A and FG-B, is compared with the pulse width of the reference pulse which is output from TCU ICC8, then the speed difference, CP, from the reference, sensed. The sensed speed difference, CP, is T-V converted, and output.

(D) T-V converter (CD-35 board)

The T-V converter has the same circuit configuration as that of the drum V-LOOP circuit. Transistor Q2 functions both as a constant current source and as a switching device, and charges capacitor C26 only when the speed difference, CP, with respect to the reference is "H" level. Because the range of the V-LOOP control voltage from the CPU is set at $\pm 9\%$ with respect to that at normal speed, the charging slope of C26 is in the range $\pm 7\%$ of that at normal speed. In this circuit, when the potential of capacitor C26 approaches 5 V, the linearity falls off. To overcome this, the T-V converted output at normal speed is set at +2 V, and the $\pm 7\%$ speed difference is converted to 2 ± 2 V.

In order to eliminate the effect of random variations in the FG pulses and the duty, two CPEX pulses are measured, and the results output to the motor drive amplifier. When the speed difference is converted into time, a figure of 26 μsec is obtained. Consequently, the slope resulting from T-V conversion is $26 \mu\text{sec}/2 \text{ V}$.

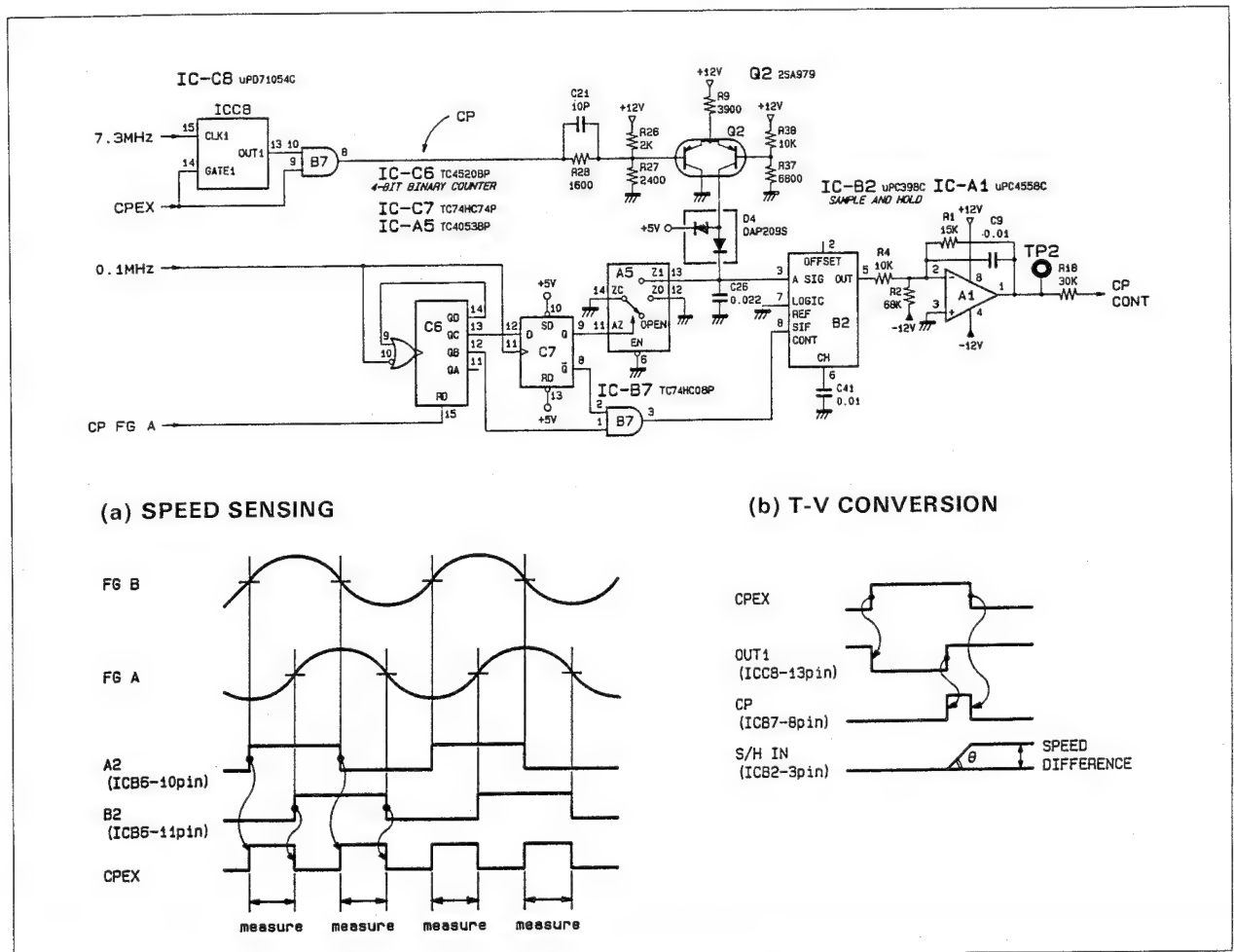

Fig. 4-3-9. Capstan Motor Speed Sensing and T-V Converter (CD-35 Board)

(E) Sample/hold timing generator (CD-35 board)

This circuit outputs the reset timing pulses for the sample/hold amplifier ICB2 and capacitor C26.

When the tape is traveling in the FWD direction, the capstan motor rotates in the counterclockwise direction, hence the timing pulses of the data sample are created from the falling edge of FG-A which has a lagging phase. When FG-A becomes "L" level, counter ICC6 starts counting. After 1 to 2 clock pulses (10 to 20 μ sec) from when the counter starts, the sample/hold amplifier, ICB2, enters the sample mode. The data sampling period is 2 clock pulses (20 μ sec). After 1 clock pulse (10 μ sec) from the end of sampling, pin 9 of ICC7 becomes "H" level, and capacitor C26 is reset. The discharge period of the capacitor is 4 clock pulses (40 μ sec).

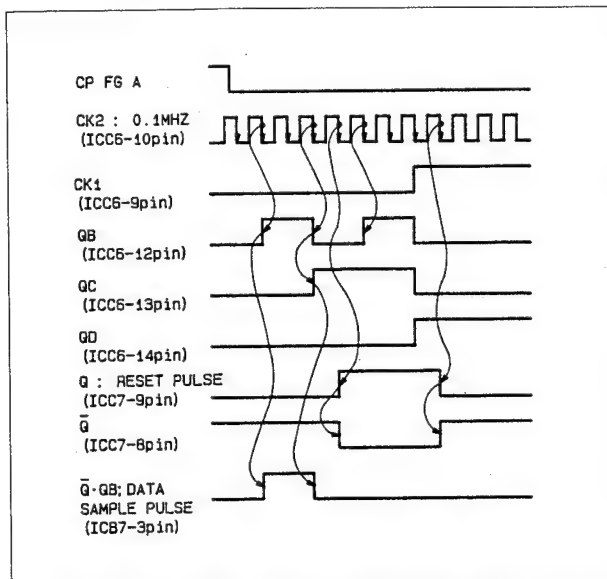

Fig. 4-3-10. Sample/hold Timing (CD-35 Board)

(F) Capstan motor drive circuit (CD-35 board)

The signal output from the sample/hold amplifier, ICB2, is speed-compensated by the CPU, then sent to the motor drive amplifier, ICA1. The gain of the motor drive amplifier is 1.5 at the front end, and 3 at the output stage.

When the system is in the PLAY mode or the REC mode, the CPU drives the motor directly via a D/A converter. This switchover is done by ICA5. When the CPU is driving the motor directly, the signal that passes through R16 and pin 2/15 of ICA5 is amplified and output. The gain of ICA1 at this time is about 2.

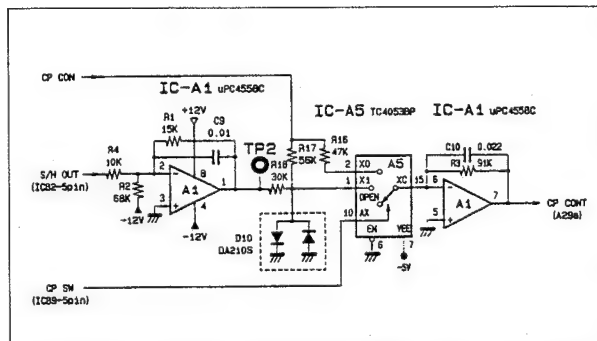

Fig. 4-3-11. Capstan Motor Drive Amplifier (CD-35 Board)

3. CTL Generator (CD-35 Board)

(A) Taking in FR/CF/AF data (CD-35 board)

Fig. 4-3-12. shows the CTL pulses prescribed by the D-1 format. In this circuit, CTL pulses are generated by ROM ICD20. ROM ICD20 creates CTL pulses from the frame pulses, FR, audio frame pulses, AF, and color frame pulses, CF.

2-frame pulses and 4-frame pulses are created as a result of frequency division of the SV FRAME pulses by counter ICD16 which is reset by the SEL CF pulses. These pulses are latched by ICD17 and sent to ICD20.

One frame of the video signal consists of 5 tracks in the case of a 525/60 system, or 6 tracks in the case of a 625/50 system. These tracks are identified by addresses A6 to A8 of ICD20. The input data to ICD17 is delayed by exactly the tracking delay, and latched. When the clock is input, the SV FRAME signal which is input to ICD17 is sent to D.FRAME (pin 15/ICD17) → D.D.FRAME (pin 5/ICD17) → D.D.D. FRAME (pin 2/ICD17) in that sequence.

Fig. 4-3-14. shows the relationship between the track number and addresses A6 to A8 of ICD20. In the 525/60 system, the D.FRAME signal may become either "H" or "L" in section (A), depending upon the tracking delay. Thus, in the section where the tracking number is 1, a mask is applied to SV FRAME, so the D.FRAME is made "L" level over the section between track numbers 0 and 2, and is made "H" level over the section between track numbers 3 and 4. The output from D7 (pin 19) of ROM ICD20 is used as the masking signal for the SV FRAME signal.

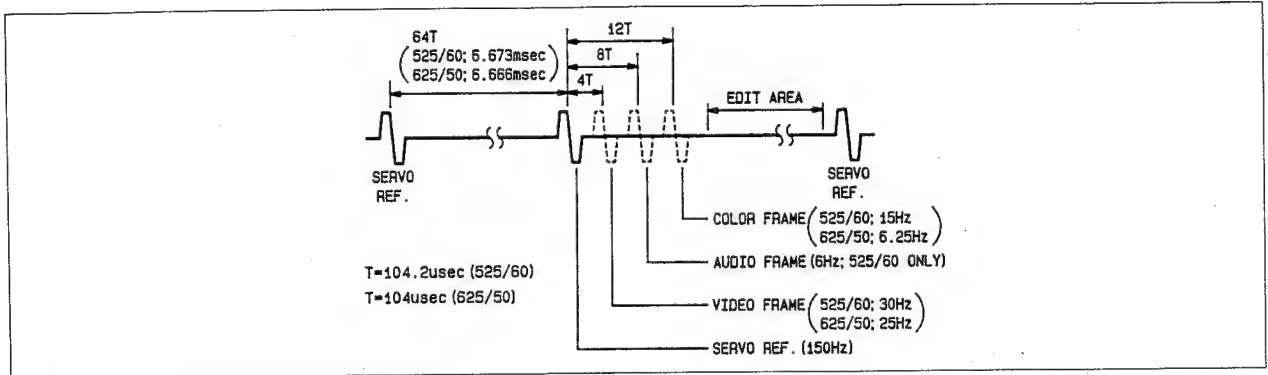

Fig. 4-3-12. CTL Waveform (D-35 Board)

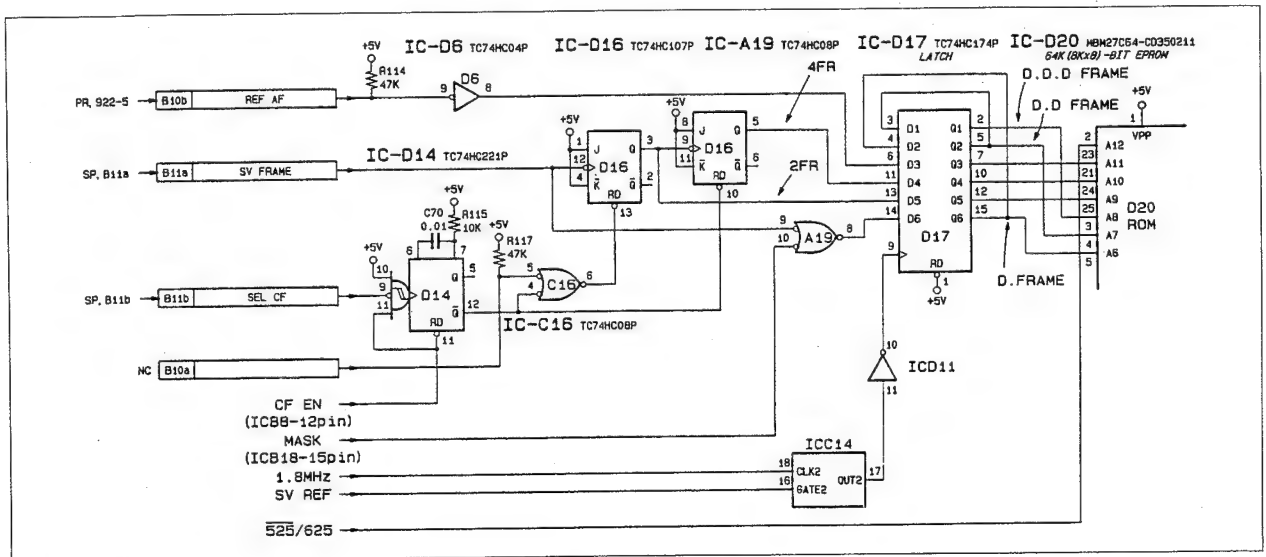

Fig. 4-3-13. FR/CF/AF Interface Circuit (CD-35 board)

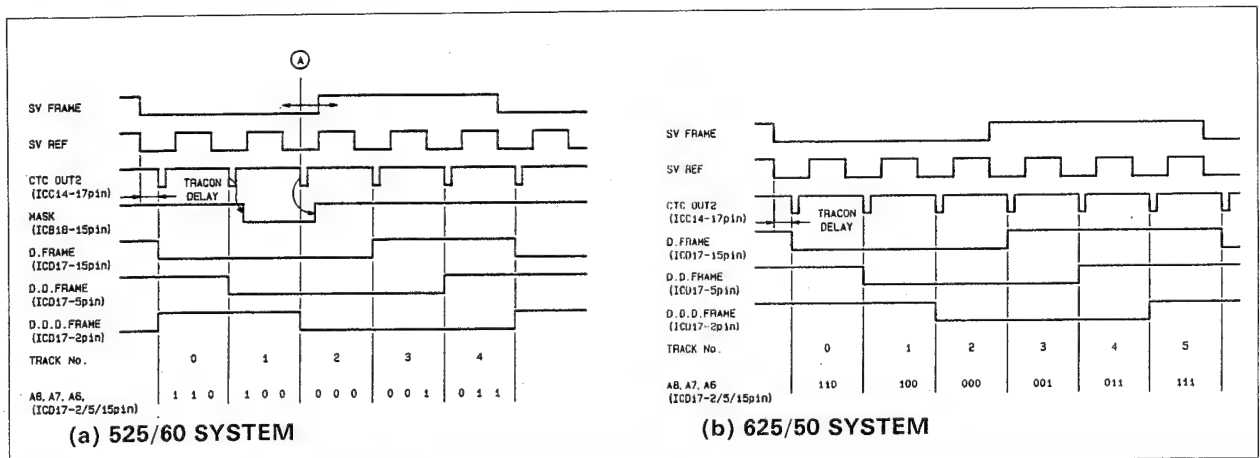

Fig. 4-3-14. Timing Chart (CD-35 Board)

(B) REC CTL CODE counter (CD-35 board)

The output of the REC CTL CODE counter, ICD19, is input to addresses A0 to A5 of the CTL generator, ICD20 (ROM). The CTL is output from pins 11 and 12 of ICD20.

As shown in Fig. 4-3-12., the CTL signal has three statuses, positive, negative, and GND. However, the output of ICD20 has only two levels, hence D0 (pin 11) and D1 (pin 12) are added to create the CTL signal. This signal is selected by IC A5 during recording, amplified by a factor of 2 by the operational amplifier, ICC2, in the next stage, and supplied to the AE-05 board.

In addition to the above CTL signal from ROM ICD20, the FR, 2FR, 4FR, and SV FRAME mask signals and the phase measurement start pulses, and so on, are output via latch ICD18. ICD18 removes noise generated when the ROM addresses are switched.

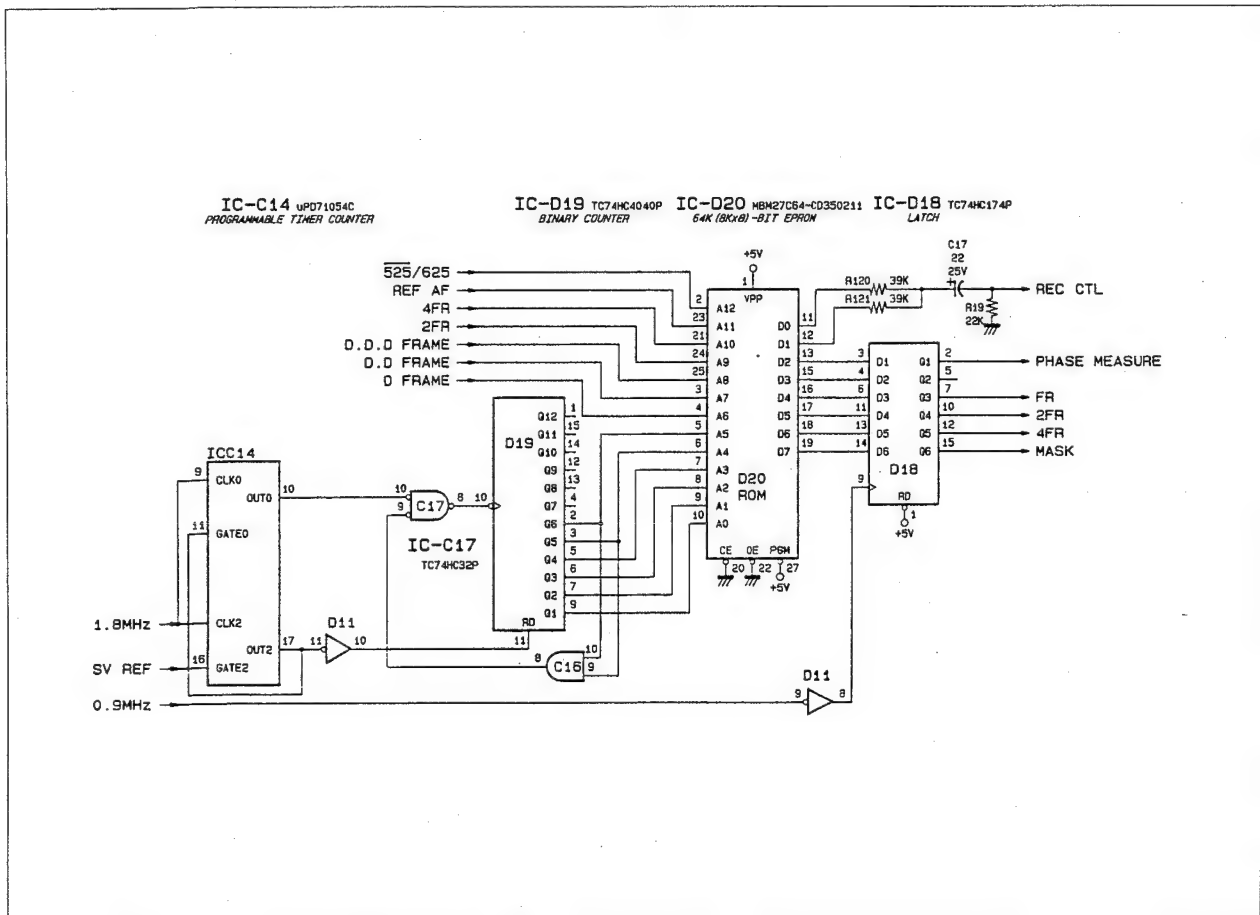

Fig. 4-3-15. REC CTL CODE Counter (CD-35 Board)

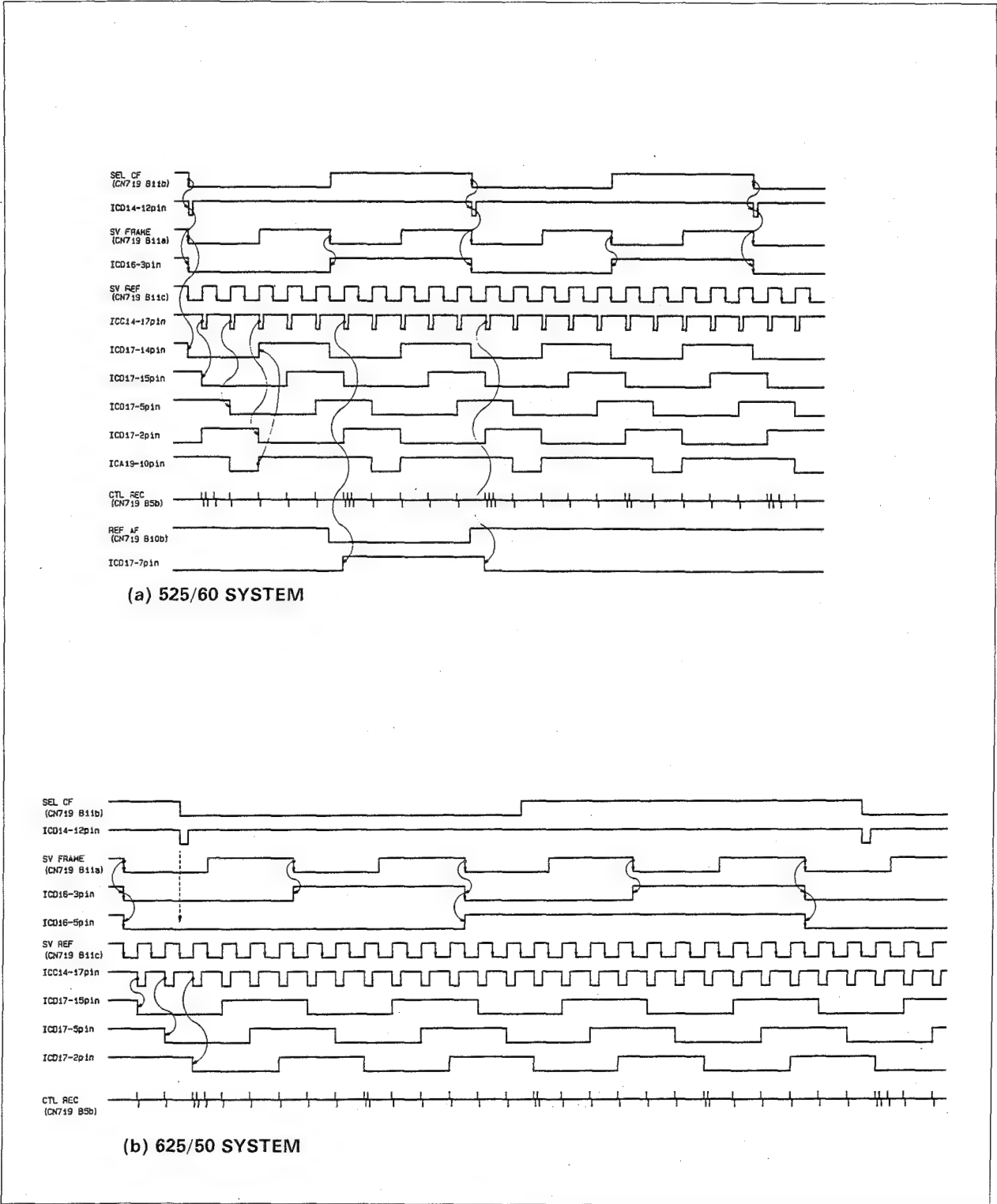

Fig. 4-3-16. CTL Recording System Timing Chart (CD-35 Board)

4. CTL Playback Circuit (CD-35 Board)

(A) CTL valid edge detection (CD-35 board)

The playback CTL signal "CTL PB" which is sent from the AE-05 board is converted into pulses by a comparator, hence it is not known which of the fall and rise is the valid edge (original CTL position). The valid edge of the CTL PB is detected from the direction of the tape travel.

Fig. 4-3-17. shows the edge detection circuit and the timing chart. The shift register, ICA13, uses a 3.6 MHz clock which is adequately faster than the CTL pulses corresponding to a tape speed of 40 times normal speed, and takes in CTL PB. The falling and rising edges of CTL PB are obtained by comparing the outputs from QB (pin 4) and QD (pin 6) of the shift register, ICA13. The result of comparison is input to the shift register in the next stage. SHIFT CK1, which is created from ICA14 and ICC15, is the operation clock of ICB19. It is output for ICB19 can take in data at the center of the SHIFT DATA (pin 6/ICA14) pulses.

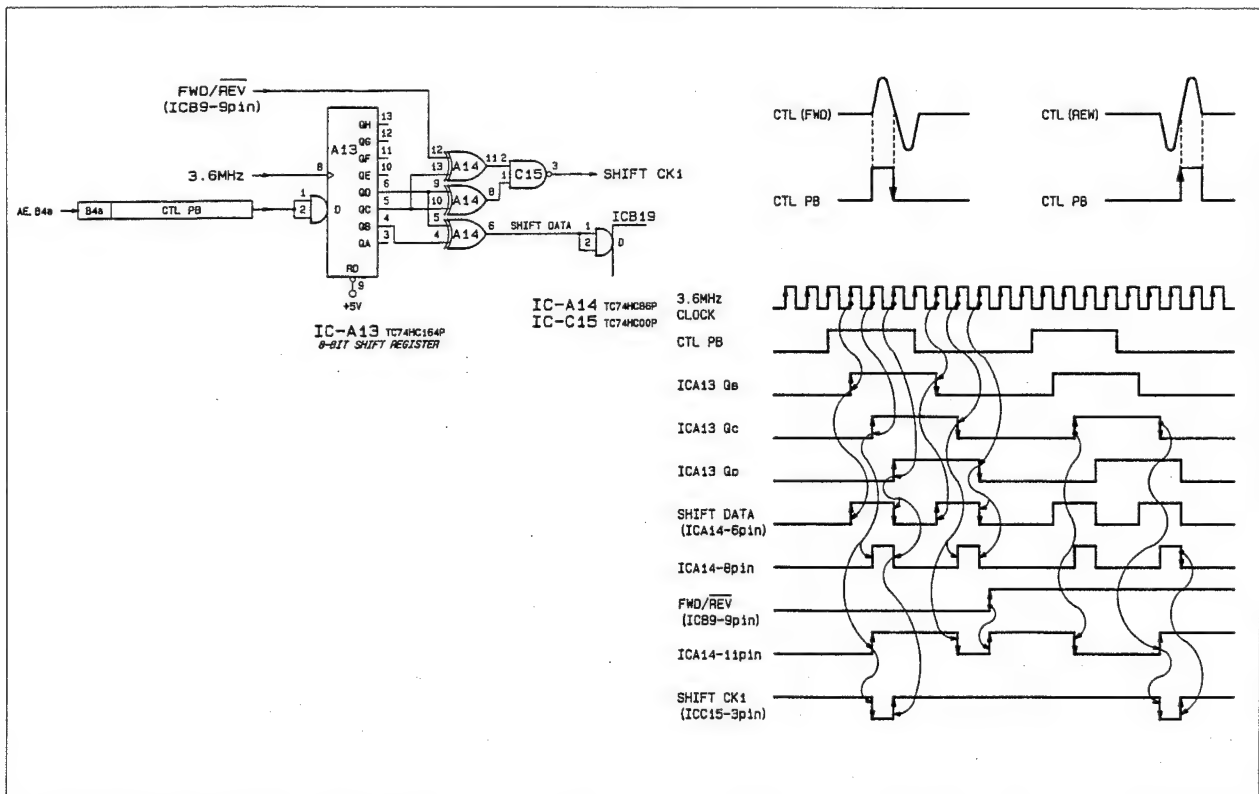

Fig. 4-3-17. Playback CTL Edge Detection (CD-35 Board)

(B) CTL blank detection circuit (CD-35 board)

The CTL signal consists of between 1 and 4 pulses, depending on the track number and the frame number. Also, in the case of the 525/60 system, audio frame pulses sometimes drop out mid-way. In order to sense that the CTL has ended, it is necessary to judge whether pulses have dropped out or the CTL has ended. This judgment is made by the blank detection circuit.

If CTL pulses have dropped out, it is necessary to input "0" to the shift register, ICB19, of the abovementioned edge detection

circuit. However, because pulses do not exist, SHIFT CK1 is not output, and data cannot be taken in. To overcome this, this circuit detects pulse dropout, and also supplies clock pulses to shift register ICB19 instead of the edge detection circuit. TCU ICC14 operates as a monostable multivibrator which has a time constant of 1.5T. If three or more continuous CTL pulses are not input, a CTL END pulse is output from pin 11 of ICC16. This pulse resets the shift register, ICB19, and is also used as an enable signal for the data which is obtained by decoding the CTL.

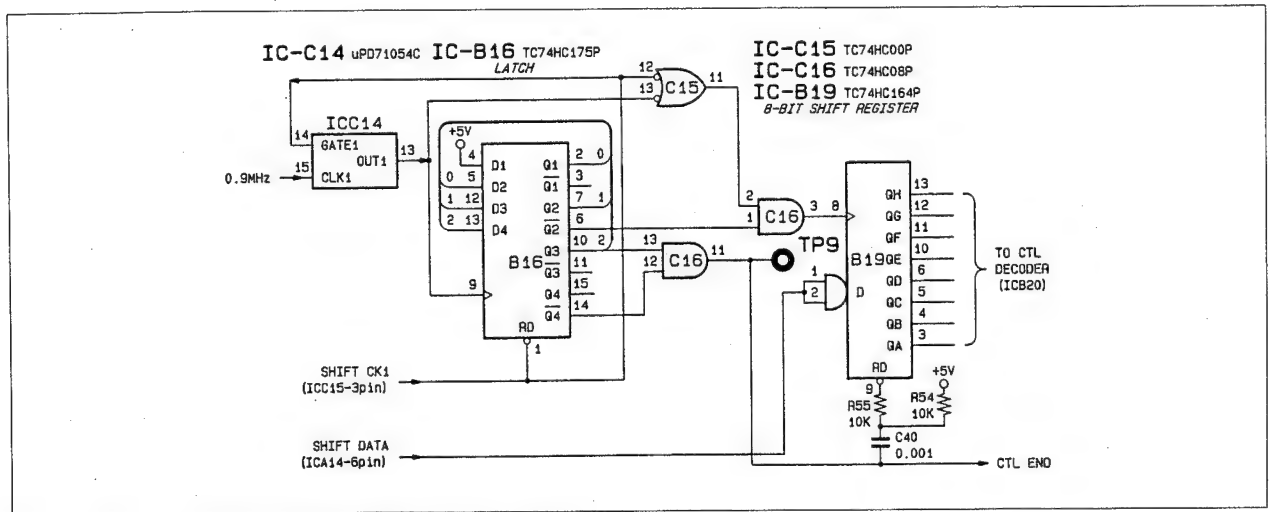

Fig. 4-3-18. CTL Blank Detection Circuit (CD-35 Board)

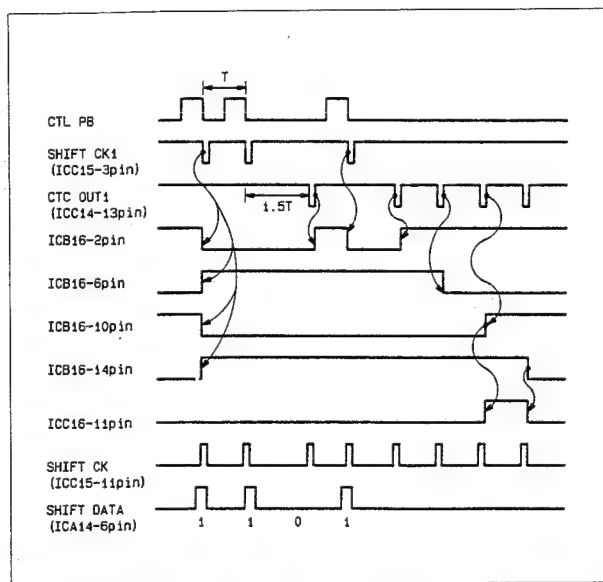

Fig. 4-3-19. CTL Detection Timing (CD-35 Board)

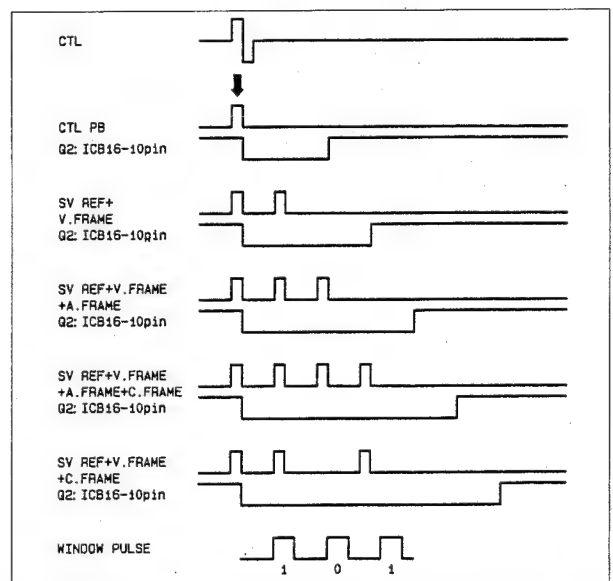

Fig. 4-3-20. 10-pin/ICB16 (Q3) Output Timing (CD-35 Board)

(C) CTL decoder (CD-35 board)

If a CTL pulse was emitted, "1" is input to the shift register, ICB19. If it was not emitted, "0" is input. The data which is converted into parallel data by the shift register is decoded into signals such as PB FR, PB CF, and PB AF, by ROM ICB20. The output enable terminal (pin 20) of the ROM is fixed at "L" level, hence noise is generated each time the output from the shift register changes. To overcome this, the output from D2 to D5 of the ROM is gated by the CTL END pulse so that data is output after the shift register has taken in one set of data.

The preset data of the playback frame counter ICB18 is output from D0 and D1 of ROM ICB20. One of 2FR (pin 6) and 4FR (pin 11), which are output from the playback frame counter, is selected by ICB15 according to the 525/625 signal, and output as the PB CF signal.

(D) Playback frame pulse generator (CD-35 board)

As shown in Fig. 4-3-21., because the PB FR pulses are created by decoding the CTL signal, the phase of the frame cannot be measured with this signal. In order to overcome this, playback frame pulses which operate at the timing reference point are created by the shift register, ICA18, and used to perform phase measurement.

The following conditions are required for the playback frame pulses and their generator.

- The edge of the pulse must be at the phase of the timing reference point of the CTL.
- Because the framing operation is performed by software, the duty must be 50% (40% or 60% for 525/60) in order to facilitate processing.

- The frame pulse generator must run freely at 1/5 or 1/6 of the frequency of the CTL signal so that it can operate with either 525/60 or 625/50 systems. It must also be capable of being preset by CTL decoder.

The output from pin 6 of ICB16 is used as the clock of the shift register, ICA18. This signal becomes "H" level at the first pulse of CTL PB. This "H" level is maintained while the CTL decoder, ICB19, is operating. The PB FR pulse (pin 11/I CA20) is the reset pulse of ICA18. During Self-generating mode a reset takes place even after the output from pin 9 of ICA18 has changed from "L" level to "H" level.

The number of tracks per frame for a 525/60 system is 5 tracks, and for a 625/60 system is 6 tracks. This circuit performs control so that when the output from pin 9 of ICA18 is a 625/50 system, the "H" level is 3 tracks and the "L" level is 3 tracks, and when it is a 525/60 system, the "H" level is 3 tracks and the "L" level is 2 tracks. Switchover between 525 and 625 is performed by pin 13 of ICA18.

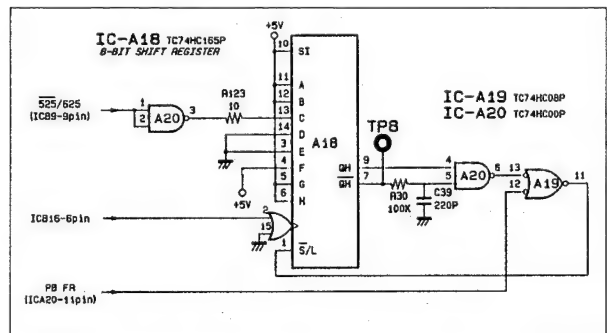

Fig. 4-3-22. PB FR Pulse Generator (CD-35 Board)

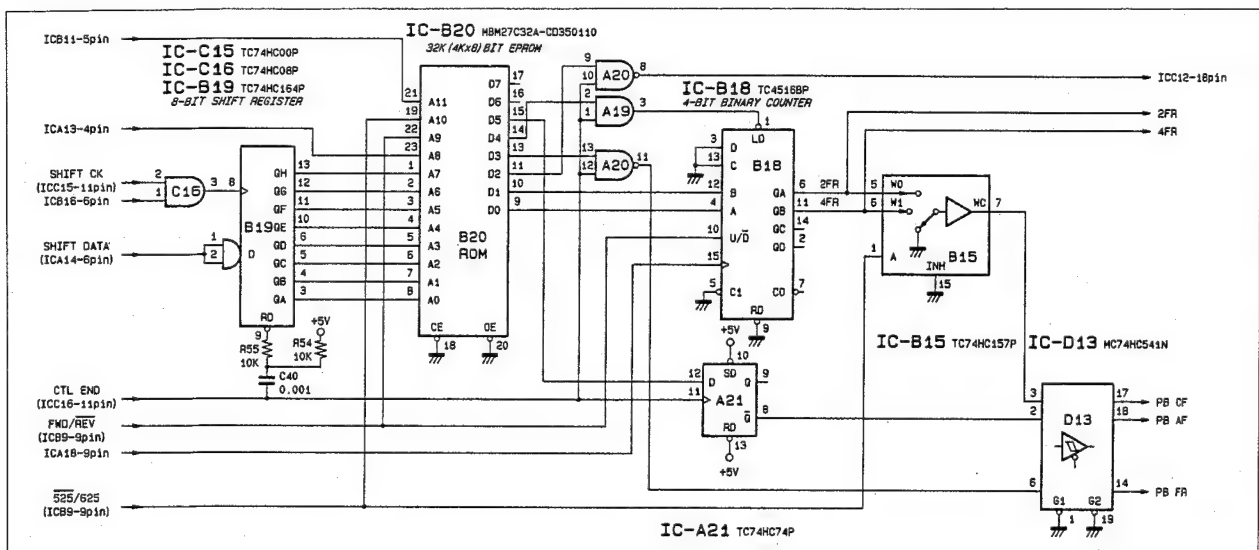

Fig. 4-3-21. CTL Decoder (CD-35 Board)

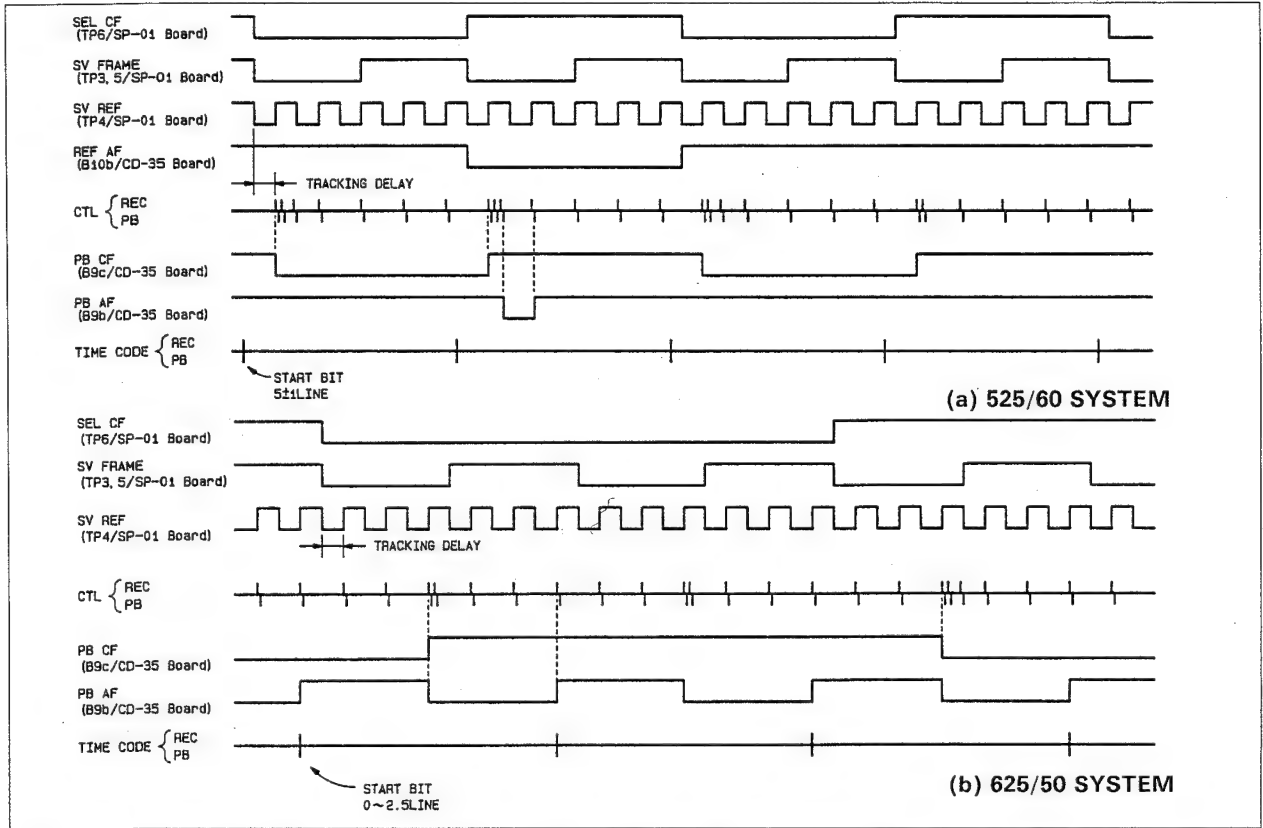

Fig. 4-3-23. Phase Relationship 1 of CTL System Input and Output Signals (CD-35 Board)

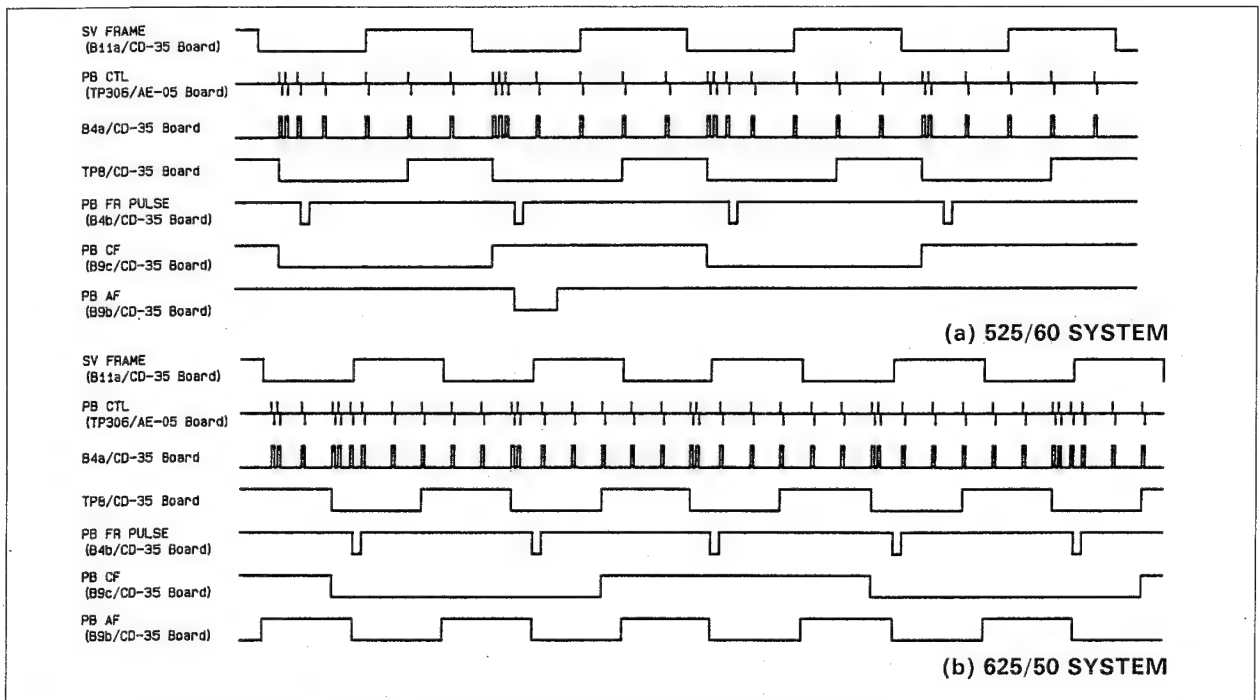

Fig. 4-3-24. Phase Relationship 2 of CTL System Input and Output Signals (CD-35 Board)

5. ADC Multiplex (CD-35 Board)

The data for the 8 channels shown below are multiplexed and supplied to the AD converter in the RS-23 board as 2-channel data. ± 5 V and ± 12 V are taken in to the POWER MONITOR via a resistive bridge, enabling any abnormality in the respective voltages to be sensed.

- Pin 12/ICC5: Capstan FG A
- Pin 14/ICC5: Tracking control
- Pin 15/ICC5: Capstan FG A duty
- Pin 11/ICC5: Drum motor control signal
- Pin 1/ICC5: Capstan FG B
- Pin 5/ICC5: POWER MONITOR
- Pin 2/ICC5: Capstan FG B duty
- Pin 4/ICC5: Capstan motor control signal

6. DAC Demultiplex (CD-35 Board)

The 8-channel data which is multiplexed and sent from the D/A converter in the RS-23 board is demultiplexed by ICD5. The following data are sent from the RS-23 board.

- Pin 13/ICD5: Capstan FG A duty control signal
- Pin 14/ICD5: Capstan FG B duty control signal
- Pin 15/ICD5: Drum motor control signal
- Pin 12/ICD5: Capstan motor control signal
- Pin 1/ICD5: Not used at present
- Pin 5/ICD5: Not used at present
- Pin 2/ICD5: Audio monitor R-CH gain control signal
- Pin 4/ICD5: Audio monitor L-CH gain control signal

4-4-4. RS-23 Board

The RS-23 board consists of the following circuits.

- SUB-CPU
- Analog reference voltage generator
- A/D converter
- D/A converter
- Reel motor control circuit
- Timer counter
- Tension sensor interface circuit
- Tape END/BEGINNING sensor interface circuit
- Sensor interface circuit

1. SUB-CPU System (ICA14/RS-23 Board)

The SUB-CPU, ICA14, uses a single chip microprocessor (μ PD78C10: NEC) containing an 8-bit A/D converter. Fig. 4-4-1. shows the address map of the SUB-CPU.

The clock of the SUB-CPU is the same 7.3728 MHz clock as that used for the HOST-CPU in the SP-01 board. The parallel I/O port ICE8 and the programmable timer counter (PTC), ICA12, are accessed by the HOST-CPU. Data exchange between the HOST-CPU and the SUB-CPU takes place via the interface RAM, ICC11. At the interface RAM, communication takes place between the HOST-CPU and the SUB-CPU at a period of V/6. The SUB-CPU does not have a WAIT terminal, so the SUB-CPU is used for 1/8 of V/6, and the HOST-CPU is used for the remaining 7/8. Because the HOST-CPU applies an interrupt at a period of V/6 when processing, it is necessary for the SUB-CPU to access the interface RAM, along with the HOST-CPU. To this end, an interrupt is applied to the SUB-CPU at a period of V/6 by the CPU INTR signal supplied from the SP-01 board, so that data transfer to and from the interface RAM ends within the specified period.

The A/D converter in the SUB-CPU is used for inputting data from the tension sensor and tape end sensor, FG duty data, etc. The D/A converter, ICA9, is used for outputting the control signals for the motor, plunger, etc. The analog input and output signal levels of the D/A and A/D converters are held within the range of ± 3.3 V by the switch power supply voltage and the maximum output from the operational amplifier.

The RS HOLD CONT signal output from pin 53 of ICA14 stops all of the motors in the tape transport in order to protect the tape if the SUB-CPU is initialized or the HOST-CPU runs out of control.

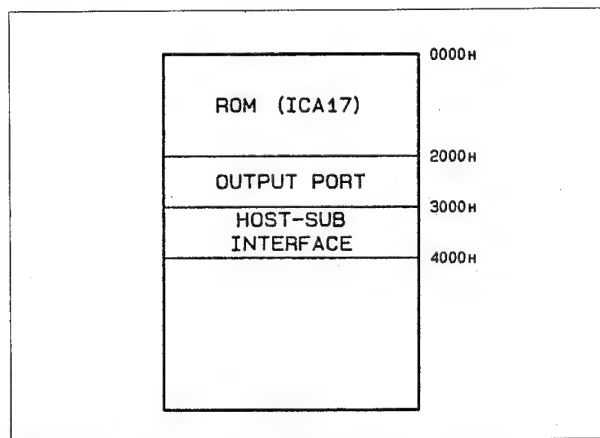

Fig. 4-4-1. SUB-CPU Address Map (RS-23 Board)

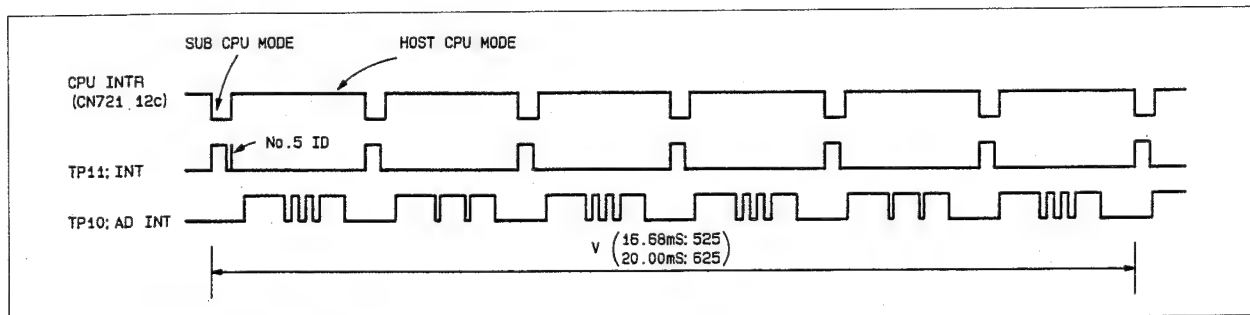

Fig. 4-4-2. SUB-CPU (RS-23 Board)

2. Analog Reference Voltage Generator (RS-23 Board)

This circuit generates the +3.3 Vdc analog reference voltage from the output voltage of Q1 according to the setting of RV3. This voltage is used not only in the RS-23 board but is also supplied to the tracking control potentiometer, the audio monitor level control potentiometer, the threading potentiometer, etc. A buffer, ICB4, is installed at the main terminal of the reference voltage to prevent noise from outside the board from affecting the analog signal system in the board.

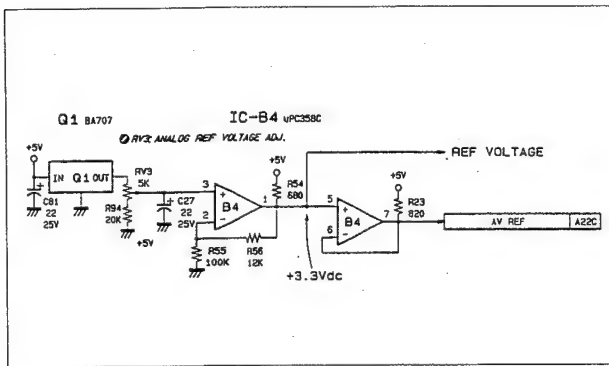

Fig. 4-4-3. Analog Reference Voltage Generator (RS-23 Board)

3. A/D Converter (RS-23 Board)

This board uses four of the eight channels of the A/D converter in the SUB-CPU, ICA14. The A/D converter input voltage is controlled within the range 0 to AV_{REF} (+3.3 V), hence in the case of a system in which it is necessary to detect a negative voltage, signals in the range -3.3 V to +3.3 V are converted into 0 to +3.3 V.

Schottky diodes D3 to D6 are connected to the input terminals of the A/D converter in order to maintain an absolute minimum input voltage (-0.5 V).

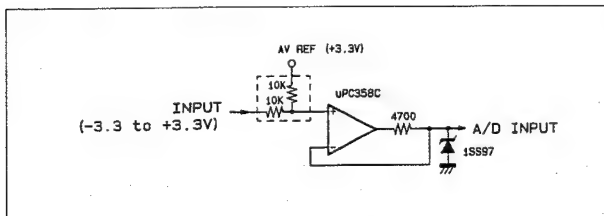

Fig. 4-4-4. Level Converter (RS-23 Board)

4. D/A Converter (RS-23 Board)

The D/A converter, ICA9, uses a μ PC648C which has a resolution of 12 bits. The digital data assigned from the SUB-CPU is converted into an analog current. The output of the D/A converter, ICA9, is sent to the next I/V converter where it is converted into a voltage. The voltage-converted data is level-adjusted by RV2, then passed through buffer ICC6 to a multiplexer consisting of ICA2 and B7. At ICA2 and ICB7, the D/A converted data are multiplexed to the respective channels according to the 3-bit signal from the SUB-CPU.

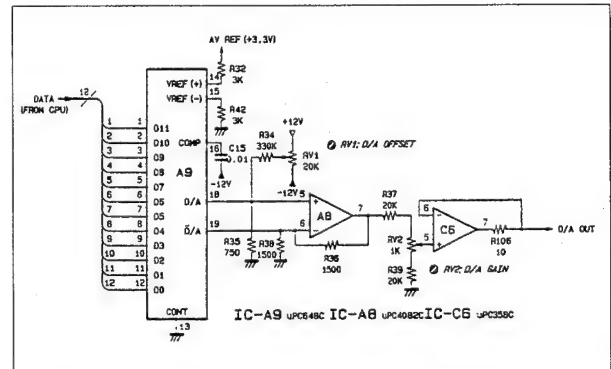

Fig. 4-4-5. D/A Converter (RS-23 board)

5. Reel Motor FG Interface Circuit (RS-23 Board)

This circuit senses the direction of rotation, angle of rotation and rotational speed that are necessary for servo control, from the FG pulses received from the T/S reel motor.

(A) Reel FG pulse generator (RS-23 board)

The FG signal output from the reel motor has a DC offset of about 5 V and an amplitude of between 1.0 and 1.6 V. Fig. 4-4-6. shows the FG interface circuit of the reel motor.

Each time the reel motor makes one revolution, 700 FG pulses are output. When the system is in the x40 speed (maximum speed) shuttle mode, the reel motor rotates at 3,000 rpm. Consequently, the maximum frequency of the reel motor FG is 35 KHz. The cutoff frequency of the filter is set at 100KHz in consideration of this maximum frequency and the phase lag of FG-A/FG-B.

In this circuit, the threshold voltage is set at +1.98 V because the power supply voltage of the comparator, ICD3, is +5 V. This voltage is created by voltage-dividing the analog reference voltage of +3.3 V.

The FG signal supplied from the reel motor has an offset of about +5 V, hence it cannot be input to the comparator directly. To overcome this, the offset is reduced to 2 V or less by means of the D/A converter output, and supplied to the comparator. ICB7, D6 and ICD7 generate the -5.0 ± 8.25 V control voltage according to the output of the D/A converter. The D/A converter is controlled by the CPU so that the duty of the pulse-converted FG signal is 50%.

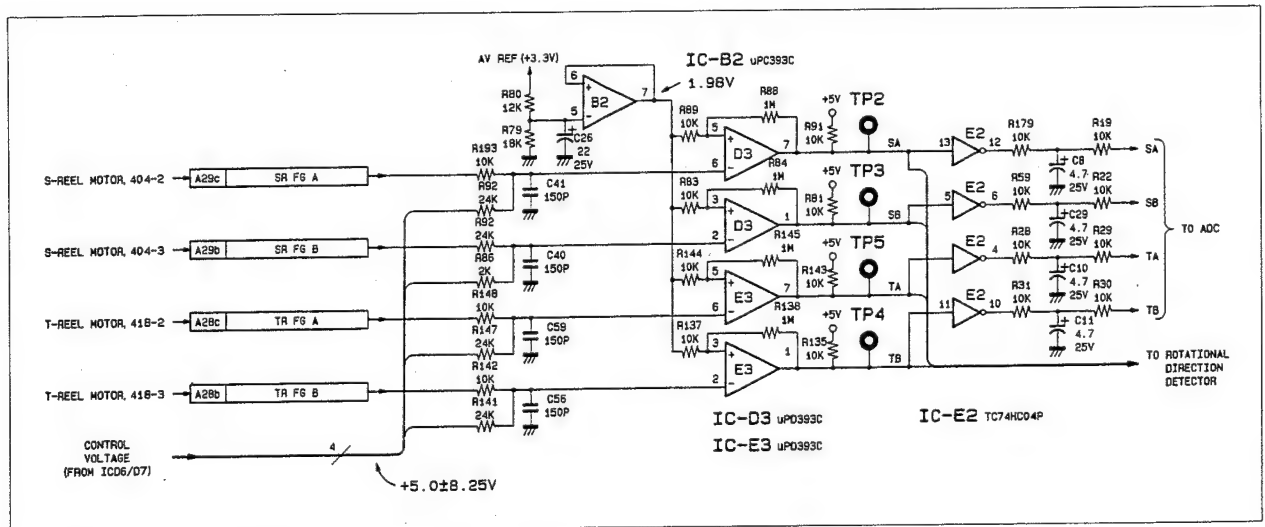

Fig. 4-4-6. Reel Motor FG Interface Circuit (RS-23 Board)

(B) Rotational direction/rotational speed sensing circuit (RS-23 board)

The direction of rotation of the reel motor is sensed by ICD13. The direction of rotation of the S reel motor is output from pin 3/ICD13, and that of the T reel motor is output from pin 6/ICD13. When each reel motor is rotating in the clockwise direction, "L" level is output, and when it is rotating in the counterclockwise direction, "H" level is output. ICD13 performs edge detection of the FG A and FG B pulses. The sensed result for the S reel motor is output from the CT1 terminal (pin 2). This signal is taken in to the counter in the SUB-CPU, ICA14, and used to sense the rotational speed of the S reel motor. The sensed result for the T reel motor is output from the CT2 terminal (pin 5). This signal is supplied to TCU ICA12, and used to sense the speed of the T reel motor.

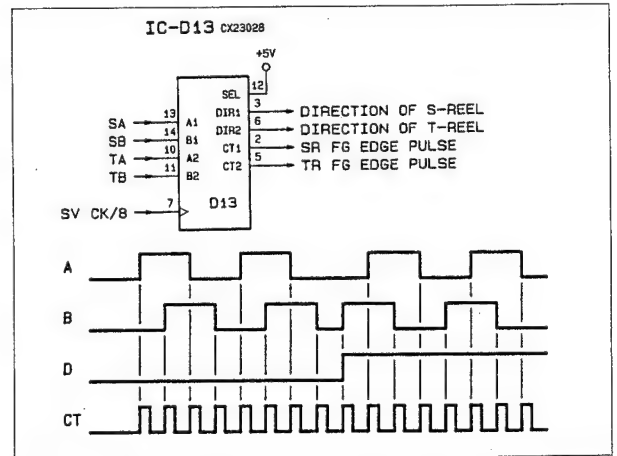

Fig. 4-4-7. Rotation Direction/Rotational Speed Sensing (RS-23 Board)

6. Timer Counter (RS-23 Board)

Normally, the timer counter counts pulses that are output in proportion to the rotational speed of the timer roller. However, the DVR-1000 has no timer roller, so the T reel FG pulses and the playback CTL pulses are counted instead.

Counter No.0 of TCU ICA12 is used in MODE-3 (rectangular wave generator). It frequency-divides the pulses output from pin 5 (CT2) of ICD13, then outputs them.

The preset value (frequency division) of counter No.0 of TCU ICA12 is controlled by the winding diameter of the T reel. This counter is reset for each frame by the PB FRAME pulses, and pulses of the same frequency as the frame pulses are output from pin 10 of ICA12. If the PB FRAME pulses are not supplied, counter No.0 outputs a number of pulses which corresponds to the preset value. The D type flip-flop, ICD12, generates a PB FRAME pulse window for resetting the timer counter. In order to remove noise from the CTL signal, the reset is inhibited during the first half of the timer pulse. The timer pulses are counted by counter No.1 of TCU ICA12.

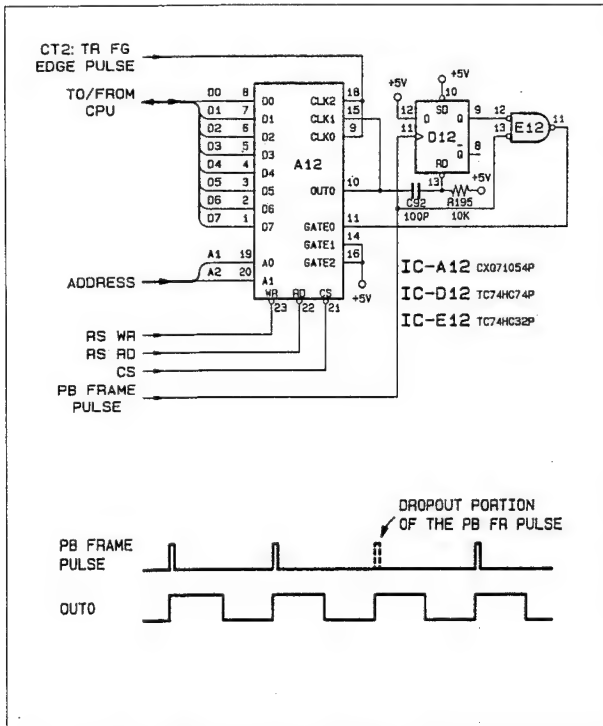

Fig. 4-4-8. Timer Counter (RS-23 Board)

7. Tension Sensor Circuit (RS-23 Board)

This circuit senses the tape tension from the motion of the tension arm.

(A) Tension sensor power supply circuit (RS-23 board)

This circuit changes the voltage applied to the sensor from the D/A converter in order to compensate for random variations in the sensitivity of the tension sensor.

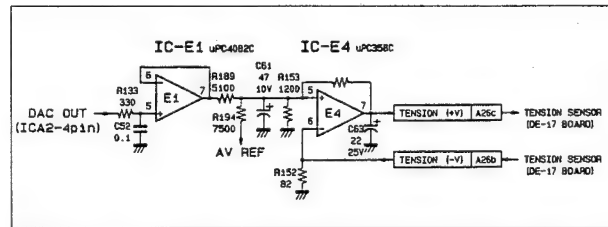

Fig. 4-4-9. Sensor Power Supply Circuit (RS-23 Board)

(B) Tension sensor interface circuit (RS-23 board)

The balanced output signal from the tension sensor is converted into an unbalanced signal by the differential amplifier, ICE4. The DC offset of this signal is removed by the operational amplifier, ICD2 (1/2), in the next stage, then the resulting signal taken in to the SUB-CPU via an A/D converter.

The tension sensor is mechanically adjusted so that the center value of the slope of the output signal corresponds to the set tension in the PLAY mode, in order to stabilize the temperature characteristics. If it is outside the range of mechanical adjustment, it is compensated by the D/A converter output. Operational amplifier ICD2 (2/2) compares the present tension value with the target value of the tension applied from the CPU, and outputs a voltage proportional to the difference between them. Here, the tension output signal which is phase-compensated by R76, 77 and C37 is compared with the D/A converter output. D8, 9 and 10 comprise a limiter which lowers the gain of the amplifier from 4 to 0.8 if the output voltage exceeds ± 2 V. The output from ICD2 (2/2) is taken in to the SUB-CPU via an A/D converter. The SUB-CPU uses this output for servo control in the PLAY mode.

The motion of the tension arm is sensed by ICB2. The motion of the tension arm is sensed by adding the AC component of the output from ICD2 (1/2) and the AC component of the output of ICD2 (2/2). The resulting signal is taken in to the SUB-CPU via an A/D converter, and used as AC servo data. The signal supplied to the A/D converter is output via a T type filter in order to remove noise.

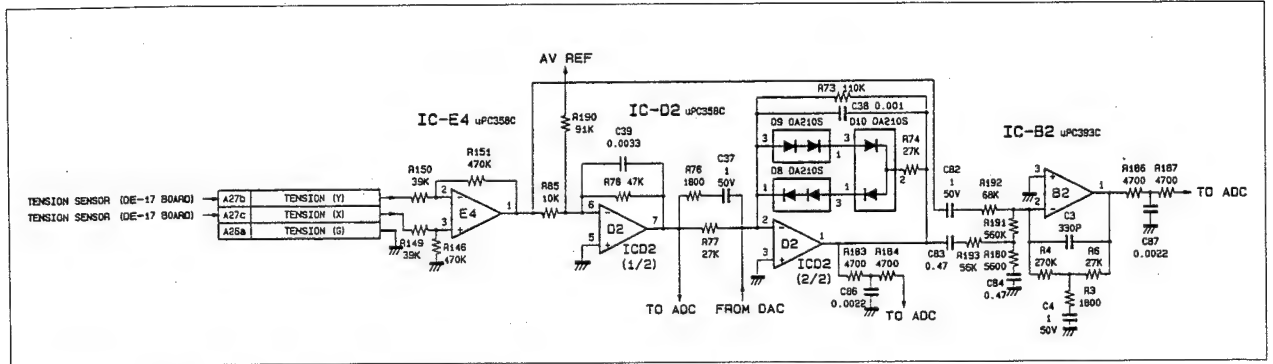

Fig. 4-4-10. Tension Sensor Interface (RS-23 Board)

8. Tape Beginning and Tape End Sensor Interfaces (RS-23 Board)

The tape beginning and tape end are sensed by LEDs and photo-transistors. These sensors have the following circuit configuration in order to prevent a malfunction due to external light striking them.

Each LED is driven by a voltage which is modulated at 1.8MHz. At the photo-receiving side, the output from the photo-transistor is passed through a 1.8MHz filter and amplified. The peak level of each amplifier output is held in a capacitor, then A/D-converted and taken in to the SUB-CPU. The tape beginning sensor and tape end sensor are driven in reverse phase to prevent noise.

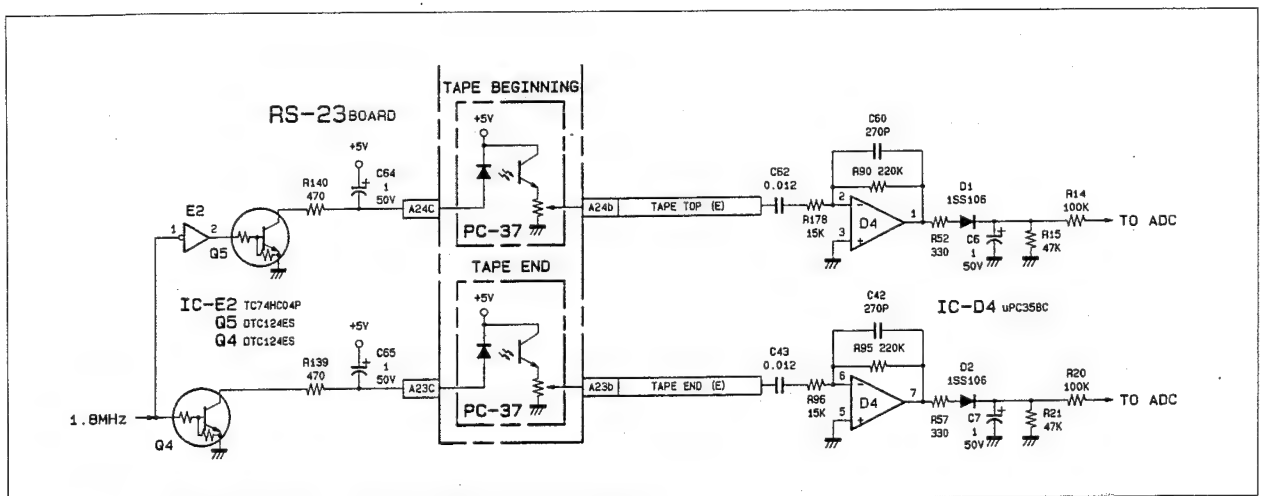

Fig. 4-4-11. Tape Beginning and Tape End Sensors (RS-23 Board)

9. LED Control Circuit (RS-23 Board)

This circuit changes the brightness of the LED to check whether or not each sensor is operating normally, during the initial sequence which takes place after the power is switched ON. The brightness of the LED varies according to the condition of D3/D4/D5 of the output port, ICE17. Normally, +5 V is supplied to each LED.

| ICE17 | | | LED CONTROL |
|-------|----|----|-----------------|
| Q3 | Q4 | Q5 | |
| 0 | 1 | 1 | OFF |
| 0 | 1 | 0 | +5V (DUTY: 50%) |
| 0 | 0 | X | +5V |
| 1 | X | X | +12V |

Table 4-4-1. LED Control (RS-23 Board)

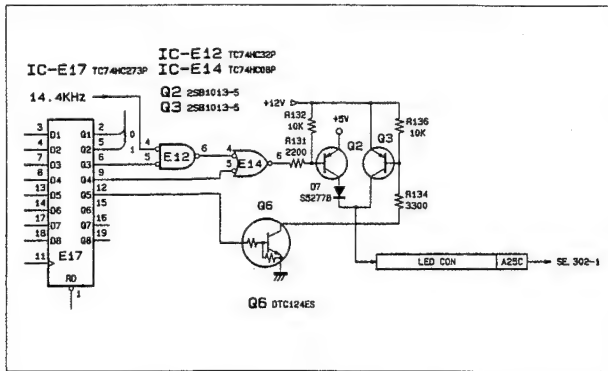

Fig. 4-4-12. LED Control Circuit (RS-23 Board)

10. RF Envelope Interface Circuit (CS-27 Board)

This circuit generates a difference signal between A/B channel envelopes and between C/D channel envelopes in order to obtain tracking information used for auto tracking. Offset is applied so that about 1.5V appear when A = B.

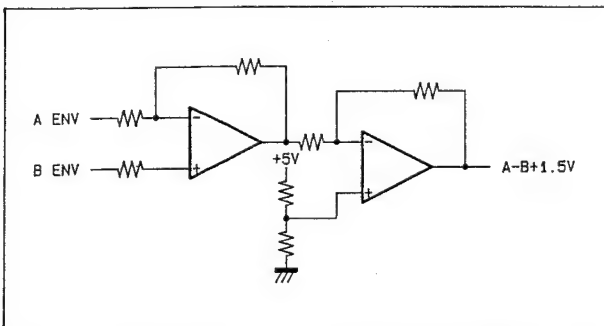

Fig. 4-4-13. RF Envelope Interface Circuit (CS-27 Board)

4-4-5. Sensor Section

The sensor section consists of the SE-47 board and various sensor boards. The main functions of the SE-47 board are as follows.

- It integrates the signals from the various sensors, then sends them through a serial bus to the SP-01 board.
- The drive signals for the front panel LEDs are received from the SP-01 board by a serial bus, then supplied to the LE-56 board and PE-18 board.
- This section passes on the drive signals from the cassette compartment motor.

The following sensors are in the tape transport of the DVR-1000.

- Cassette up/down sensor (PC-37 board)
- Cassette in sensor (PC-37 board)
- Cassette size sensor (PC-37 board)
- User hole sensor (PC-34 board)
- Reel position sensor (PC-34 board)
- Coding hole sensor (LE-52/TR-41 board)
- Tension sensor (DE-17 board)
- Tape beginning/end sensor (PC-36 board)

Fig. 4-5-1. shows the location of each sensor. The tape beginning/tape end sensors are driven directly from the RS-23 board, hence they are not described in this section. For details of these sensors, see 4-4-4. "RS-23 board".

The "cassette in", "cassette size", "cassette up", and "cassette down" sensors are installed in the cassette compartment. The status of these sensors is sent to the SE-47 board via the CS-21 and CC-29 boards.

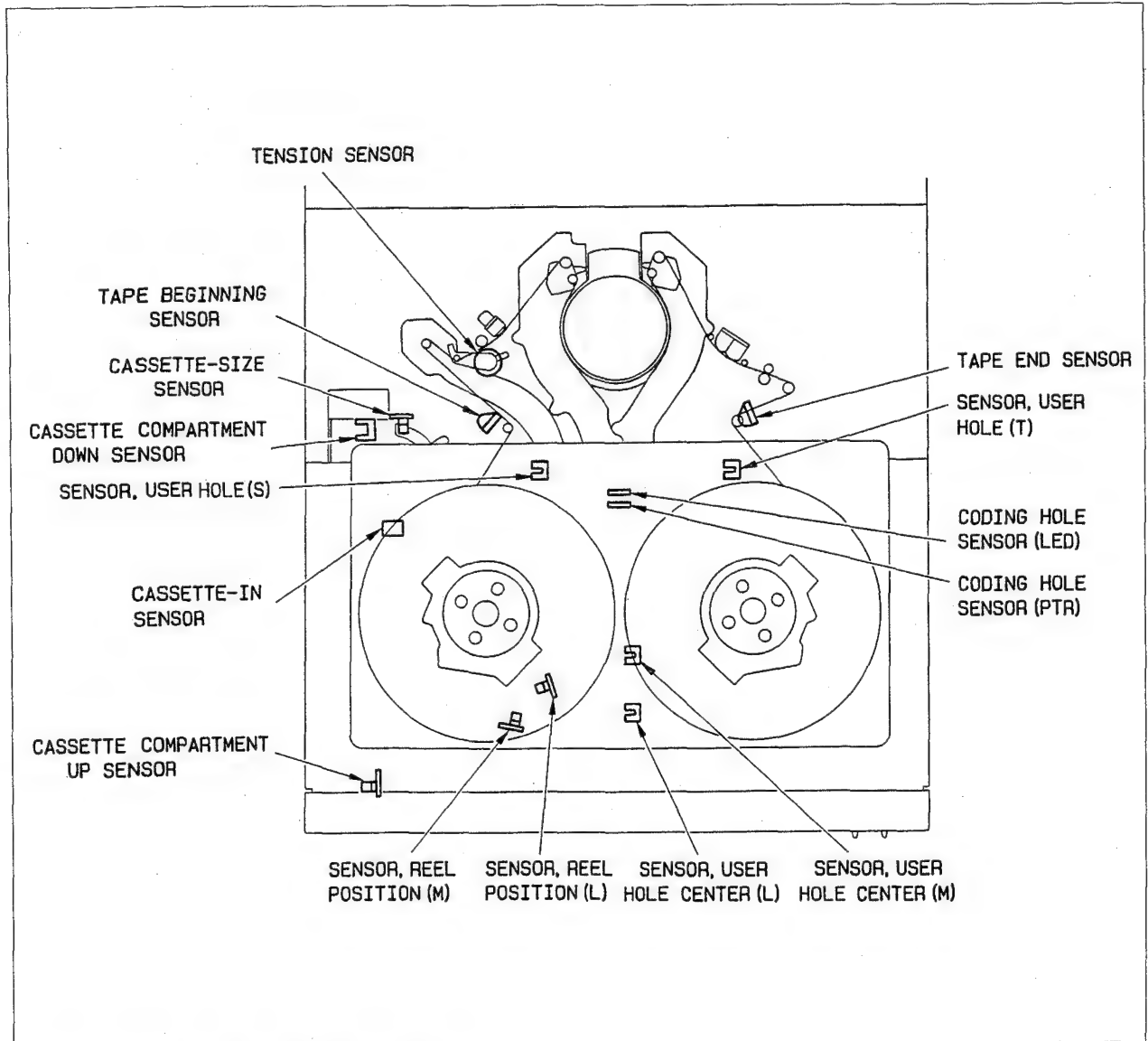

Fig. 4-5-1. Sensor Locations (Threading positions)

**1. Sensors and Peripheral Circuits
(SE-47/PC-xx/SW-179 Boards)**

The sensors are long-life, high reliability contactless type photosensors. Each photosensor consists of a light sending section using an LED and a light receiving section using a phototransistor. The LED drive voltage "LED CONT" is supplied from the RS-23 board. The phototransistor section is an open collector type, hence the input is pulled up to +5 V. The pull-up resistor may be either 22 K Ω or 100 K Ω depending on the construction of the sensor.

The sensor output signal passes through an RC filter consisting of a 220 K Ω resistor and a 0.022 μ F capacitor to the buffer consisting of IC4, 5 and 6. The buffer uses a CMOS type inverter IC. When the sensor output is 1.5 V or less, "L" level is output, and when it is 3.5 V or more, "H" level is output. The eject switch (SW-179 board) at top right of the front panel is connected to the SE-47 board. When the eject switch is pressed, an "L" level signal (EJECT) is input to the SE-47 board.

These signals are converted into serial data by IC1 and IC2, and sent to the SP-01 board.

2. Front Panel LED (SE-47/LE-56/PE-18 Boards)

The drive signals for the front panel LEDs are sent from the SP-01 board as serial data. These signals are converted into parallel data by IC3 on the SE-47 board, then pass through Q1 to Q4 of the LED driver and supplied to the LEDs on the LE-56 board.

The +5 V power supply voltage output from pin 5 of CN-307/SE-47 passes through the LE-56 board to the PE-18 board. It is also used as a drive power supply for the POWER LED on the front panel.

**3. Transferring Cassette Compartment Signal
(CS-21/CC- 29/SE-47 Boards)**

The cassette compartment motor drive signals "CC Motor" which are supplied from the MD-43 board are sent via the SE-47 board to the CS-21 board together with the signals from the other sensors. There are two transfer boards (CS-21 board and CC- 29 board) in the cassette compartment.

4. Tension Sensor (DE-17 Board)

This sensor board is installed at the bottom of the tension regulator shaft. Only the tension sensor DM208 (DME: Divided Magneto Element) is mounted on it.

The magnets mounted around the DME rotate according to the motion of the tension arm. As a result, a fluctuating magnetic field is generated. The DME converts this fluctuation into a varying voltage, and outputs this voltage to the RS-23 board. Consequently, the mounting position of the DME must be located at the center of the magnetic field created by the magnets.

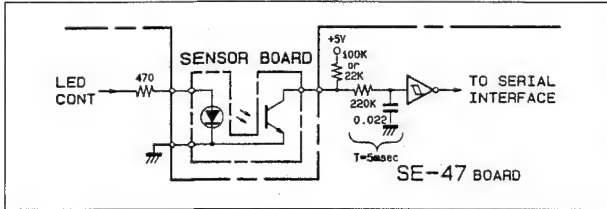

Fig. 4-5-2. Sensor Interface (SE-47 Board)

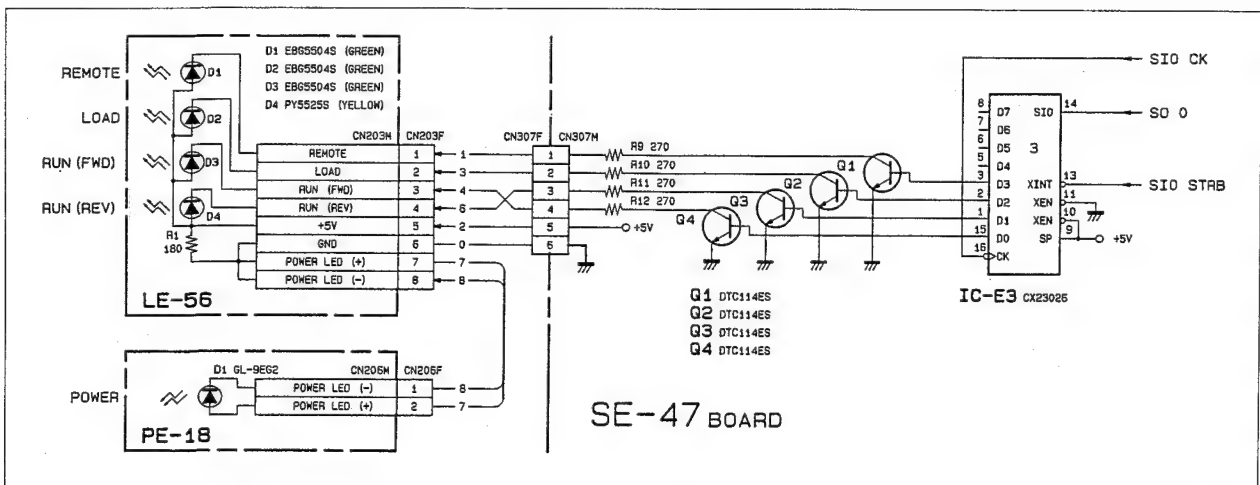

Fig. 4-5-3. Front Panel LEDs (SE-47/LE-56/PE-17 Boards)

4-4-6. MD-43 Board

The MD-43 board drives the various motors and solenoids in the DVR-1000. It is installed in a power case to facilitate dissipation of the heat generated because of its small size. This also prevents high level switching noise from getting into other signal processing boards.

The power supply section supplies voltages of +40 V and +14 V to the MD-43 board for driving motors, and ± 12 V and +5 V for the circuits in the board. The control signals for each motor/plunger are supplied from the SP-01 board and the RS-23 board. The MD-43 board is used to drive each motor/plunger according to the control signals, using the power supplied from the power supply section.

The devices controlled from the MD-43 are broadly divided into those which drive the tape and those which load the tape. The former are the drum motor, reel motor and capstan motor, and the latter are the threading motor, reel position motor, cassette compartment motor the reel brake plunger and the capstan pinch solenoid.

The drum motor, reel motor and capstan motor are 3-phase bi-directional brushless motors. The drive amplifier drives each motor by passing current through two windings at the same time.

1. Drum Motor Driver (MD-43 Board)

The drum motor driver consists of a drive voltage generator and a 3-phase switching circuit. The drive voltage generator generates a voltage which is proportional to the control signal received from the servo system, in order to control the speed of the drum motor. The 3-phase switching circuit correctly switches the voltage output from the drive voltage generator, and supplies it to the drum motor.

The rotation direction signal which determines the switching direction of the drum is sent from the servo system via a serial bus together with the control signal for the threading system. In the MD-43 board, these signals are converted into parallel signals by IC501, and supplied to the drum.

Fig. 4-6-1. shows the circuit diagram of the drum motor.

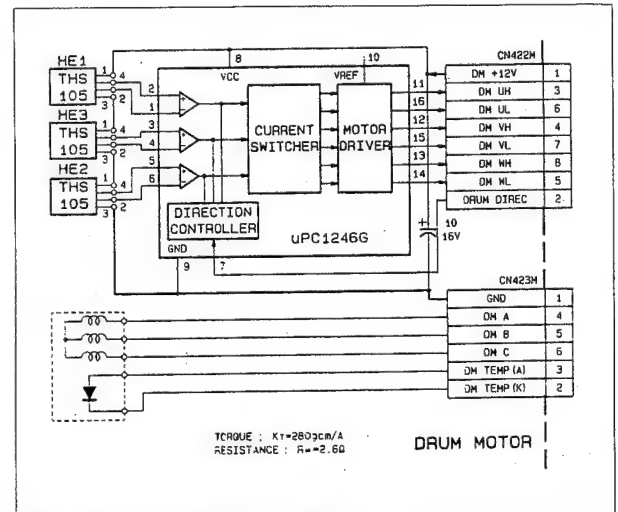

Fig. 4-6-1. Drum Motor

(A) Drive voltage generator (MD-43 board)

This circuit is a kind of switching regulator. It converts the +40 V supplied from the power supply section into the correct drive signals, in accordance with the DM CONT signal from the servo system. Fig. 4-6-2. shows the drive voltage generator.

Switching control is done by IC101. Here, the DM CONT signal and the drive voltage are compared by R101 and R102, and the error voltage pulse width modulated and output from pins 9 and 10. As can be seen from the ratio between R101 and R102, IC101 controls the drive voltage so that it becomes five times that of the DM CONT signal. The frequency of the output pulses is constant at about 100 KHz. The pulses output from pins 9 and 10 of IC101 are in the same phase. The period during which the pulses output from pin 9 are "L" level is increased in order to stabilize the operation of the switching circuit. The "L" level period of these pulses increases when the drive voltage is lower than the voltage determined by the DM CONT signal.

The IC101 output pulses pass through a buffer consisting of IC102 and 103 to drive the switching devices Q101 and 102. This circuit uses a POWER MOS FET to enable switching to take place using few relatively high speed switching component. Q101 is an N channel FET. If the drive voltage is lower than the voltage determined by DM CONT (drive mode), Q102 will operate as a switch and Q101 as a flywheel diode, causing power to be supplied to the drum motor.

Conversely, if the drive voltage is high (brake mode), Q101 will switch, and power will be returned from the motor to the power supply section. L104, 105, and C105, 106 comprise a filter which converts the switched signal into direct current, thus creating the drum motor drive voltage.

IC101 contains an overpower prevention circuit which prevents an excessive power from being applied to the drum motor, and also a reverse current limiting circuit which limits the flow of reverse current to the drive circuit when the brake mode.

The overvoltage prevention circuit is intended to protect the motor and drive circuit in the event that a breakdown occurs in the control circuit. It uses R104, 115 and D101 to sense the current and power supplied to the motor, and controls the "L" level width of the output pulses so that the current dose not exceed 2.2 A and the power 50 W. The reverse current flow limit circuit limits the current flowing into the drive circuit from the motor when the brake mode. If this circuit is not provided, there is a risk that a current exceeding the rated current of the MD-43 board will flow from the motor, causing the motor or switching FET to brake down. The current is sensed by R115, and the "L" level width of the output pulses are controlled so that the reverse direction current dose not exceed 3 A.

R129, 130 and D106 constitute an IC protection circuit which prevents IC101 from latching up in the event that a large negative voltage is applied to the input.

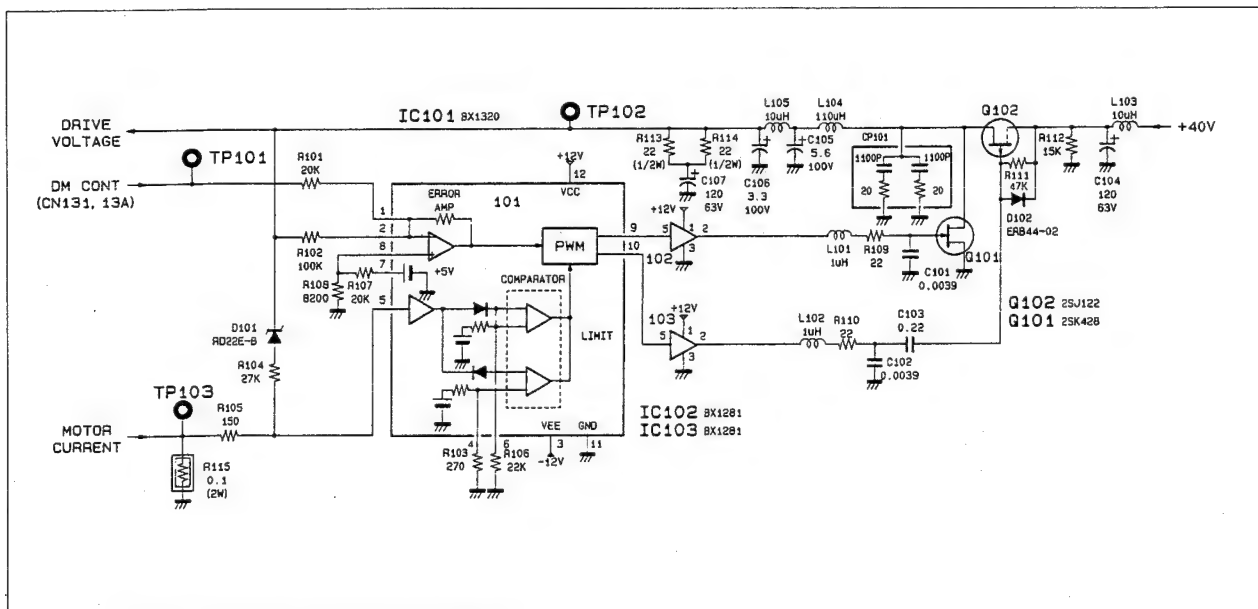

Fig. 4-6-2. Drive Voltage Generator (MD-43 Board)

(B) 3-phase switching circuit (MD-43 board)

Fig. 4-6-3. shows the 3-phase switching circuit. As mentioned previously, a 3-phase motor is used for the drum motor. This circuit supplies the drive power output by the drive voltage generator to each winding in the correct sequence according to

the phase and direction of rotation of the drum motor.

The DVR-1000 drum motor contains a circuit which generates a signal that senses the phase and turns the 3-phase switching device ON and OFF. IC104 on the MD-43 board performs switching in accordance with this signal.

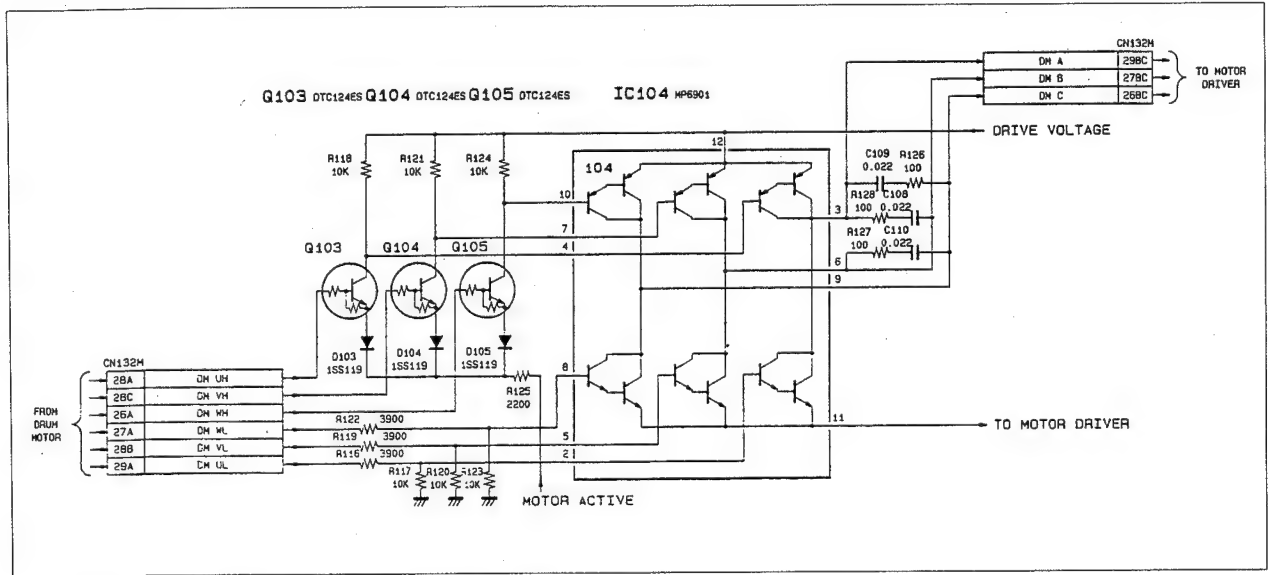

Fig. 4-6-3. 3-phase Switching Circuit (MD-43 Board)

2. Reel Motor Driver (MD-43 Board)

The reel motor driver has two circuits, one for the supply reel motor (hereafter called S reel motor) and one for the takeup reel motor (hereafter called T reel motor). The configuration of both circuits is the same, hence the following description is given for the S reel motor only.

The reel motor driver consists of a current control type drive amplifier which is used to perform tension control and acceleration and deceleration control at constant torque. The drive amplifier consists of a constant current circuit which drives the reel motor at a constant torque, and a PWM constant voltage circuit which is used to reduce power consumption. These circuit are controlled by IC201.

Like the drum motor, the reel motor contains a circuit which generates a switching signal according to the rotating phase. In order to generate this signal, the signal from the servo system which specifies the direction of rotation of the reel motor is sent from the MB-137 board directly to the reel motor.

Fig. 4-6-4. shows the circuit diagram of the reel motor.

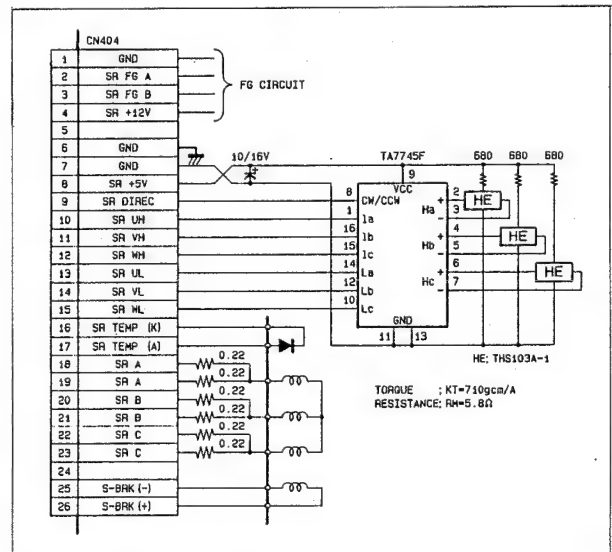

Fig. 4-6-4. S Reel Motor

(A) Constant current circuit (MD-43 board)

This circuit is used to rotate the reel motor at constant torque. In this circuit, the current flowing through the reel motor is detected by R206, then compared with the voltage level of the SR CONT signal received from the servo system. The torque of the motor is controlled by this circuit so that this ratio (current gain) is constant (739 mA/V, interface at 500gcm/V). R204 is an offset adder resistor. The MD-43 board, which does not have an offset adjustment potentiometer, receives offset-compensated control signals from the servo system. However, the control signal is a unipolar signal, hence if the IC201 has positive offset, the motor may sometimes fail to be controlled. To overcome this, a potential is applied to the inverting input terminal of IC201 by means of an offset adder, resulting in an overall negative offset.

The control current which flows into the motor is controlled by Q201, 202 and 203. These transistors also function as 3-phase switching devices for the absorb direction. IC201 applies base current to these transistors for constant current control and switching control. IC201 compares the motor supply current with the control voltage, and the resulting error signal is applied to one of the transistors in accordance with the phase information supplied from the motor, thus maintaining the current flowing through the motor constant. IC203 is installed to align the voltage levels in the signal lines for the motor (+5 V) and IC201 (+12 V), which are driven by separated power supplies.

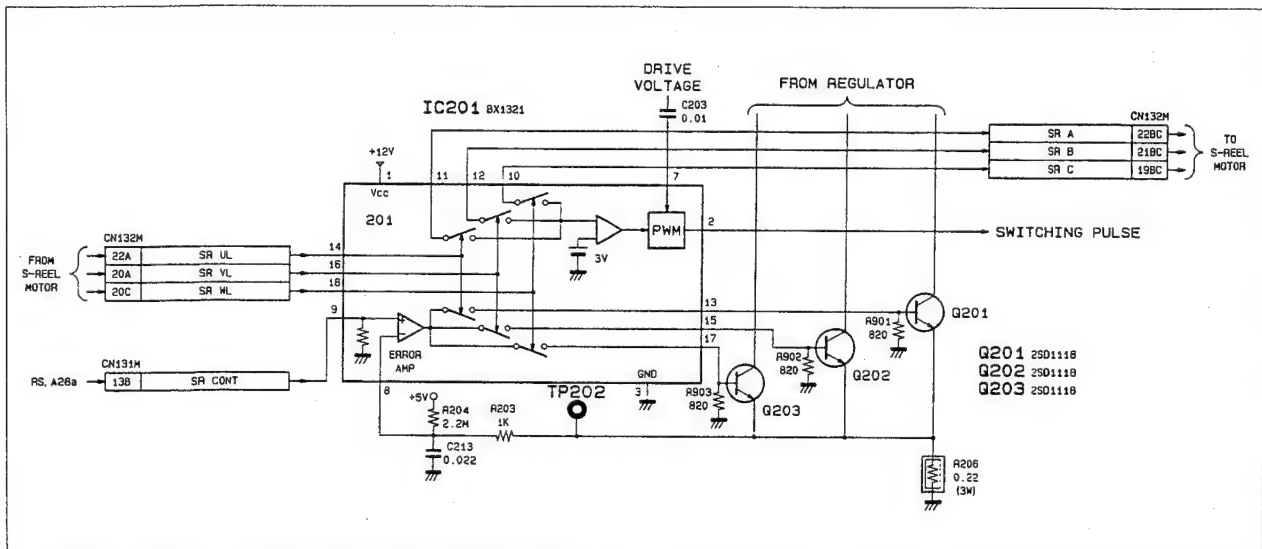

Fig. 4-6-5. Constant Current Circuit (MD-43 Board)

(B) Constant voltage circuit (MD-43 board)

The reel motor driver, which is a constant current control amplifier, contains a PWM constant voltage circuit in order to reduce power consumption. This circuit functions to apply exactly the voltage necessary to supply the current required by the motor. Concretely, it senses the collector voltages of Q201, 202 and 203, and operates so as to maintain a constant potential (approx. 3 V).

The constant voltage circuit is controlled by IC201 in the same way as for the constant current circuit. IC201 selects a collector voltage for the transistor selected according to the phase information supplied from the motor, from the voltages

applied to the control transistors in each phase. This voltage is compared with the internal reference voltage, and the error pulse width modulated and output. This output pulses drive the switching transistor Q204. This transistor is a MOS FET, as in the case of the drum motor driver. No absorb brake is applied to the power supply side for the reel motor, hence a single transistor switches the +40 V from the power supply. The switched voltage is then passed through a filter to become the reel motor drive voltage. This drive voltage is switched by IC202 in accordance with phase information from the motor, and is then supplied to the motor.

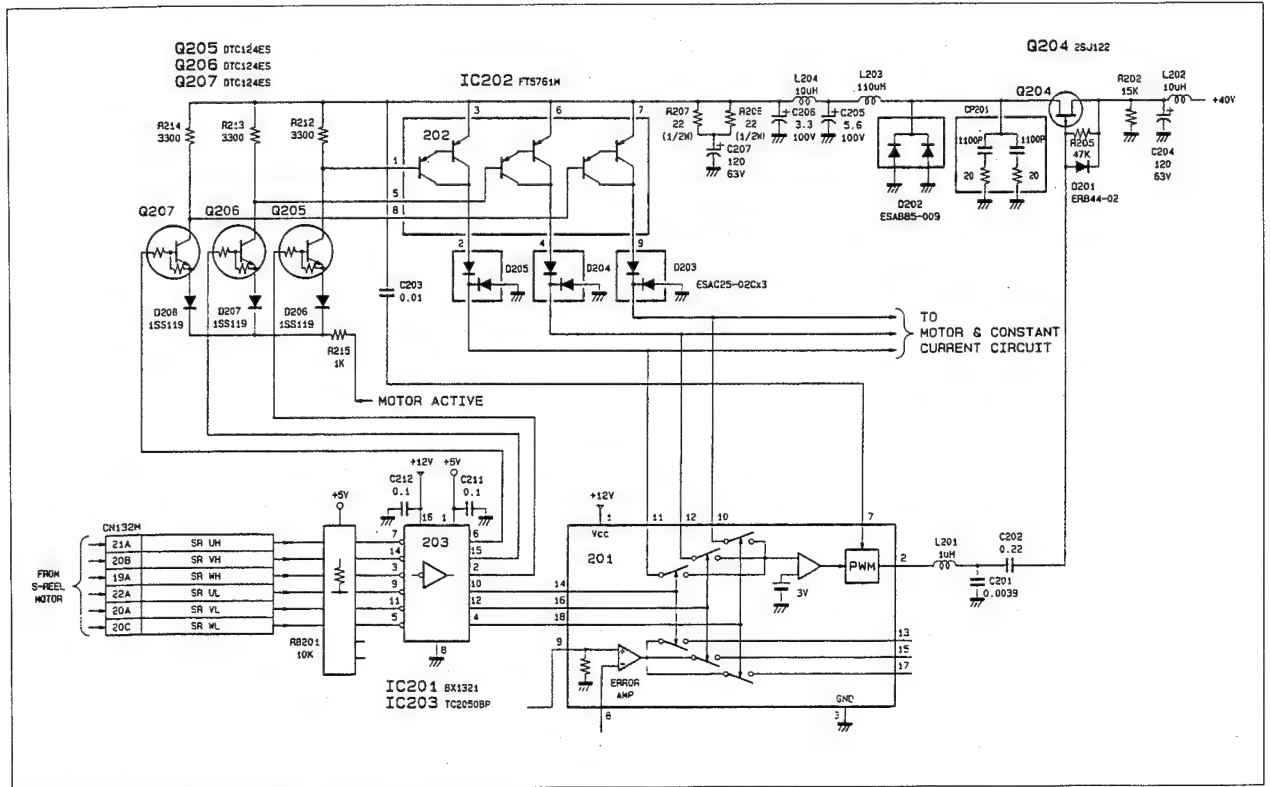

Fig. 4-6-6. Constant Voltage Circuit (MD-43 Board)

3. Capstan Motor Driver (MD-43 Board)

Fig. 4-6-7. shows the circuit diagram of the capstan motor. The capstan motor used in the DVR-1000 contains a 3-phase switching circuit. The capstan motor driver consists of a power amplifier for supplying power to the capstan motor. The CP CONT signal which is supplied from the servo system is input to the operational amplifier IC401 and voltage-amplified. At maximum output, the final stage of a single amplifier cannot drive the servo system, so another IC401 is connected in parallel to provide additional drive current.

The output stage is a push-pull circuit consisting of transistors Q401 and 402 to prevent the absorb brake from being applied to the capstan motor. Q403 controls the base potential of Q402 in accordance with the output potential of IC401, and switches the operation (drive/brake) of Q402.

The signal supplied from the servo system which specifies the direction of rotation of the capstan motor passes through the MB-137 board, and is then supplied directly to the capstan motor.

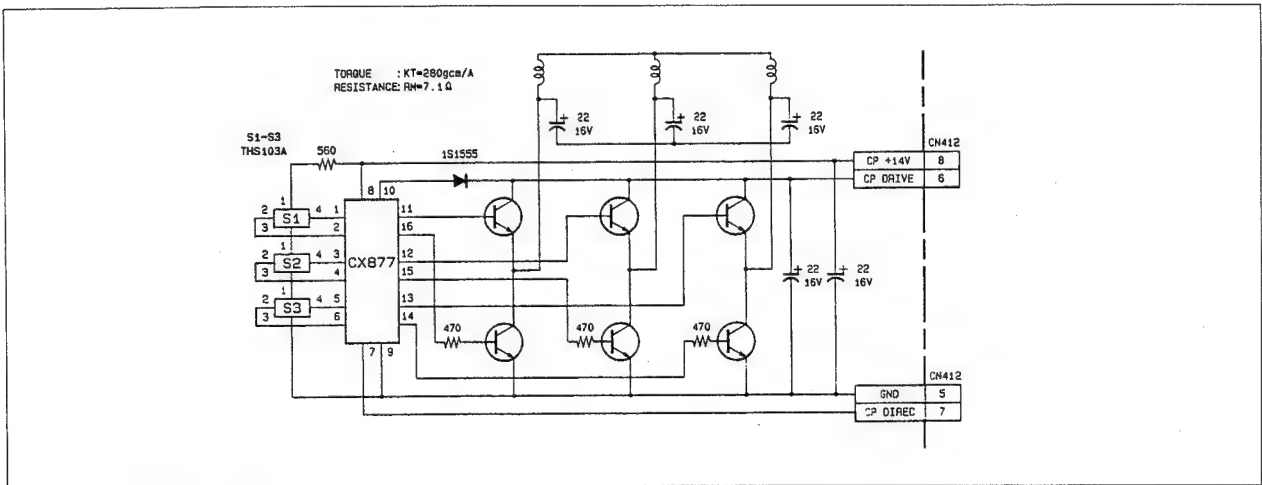

Fig. 4-6-7. Capstan Motor

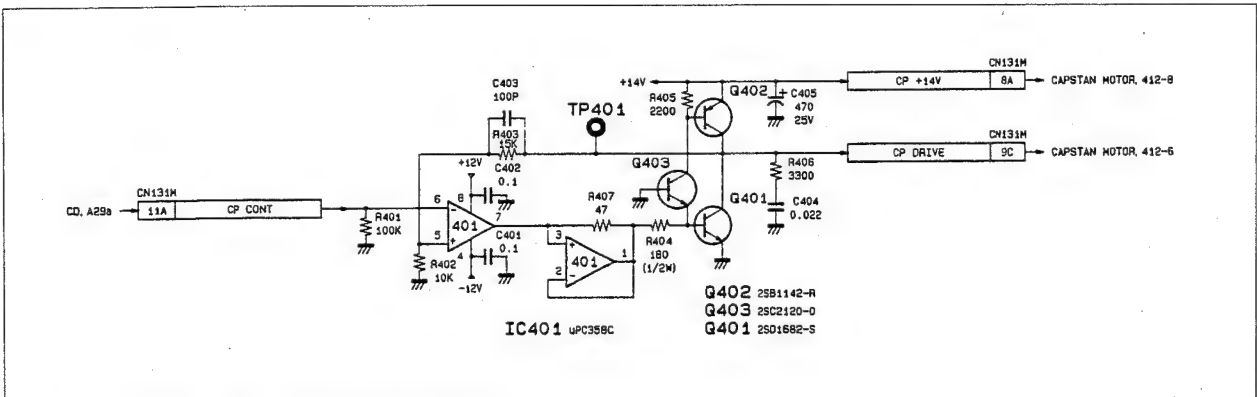

Fig. 4-6-8. Capstan Motor Driver (MD-43 Board)

4. Threading System (MD-43 Board)

The motors and solenoids in the threading system are the threading motor, reel position motor, cassette compartment motor, reel brake plunger, and capstan pinch solenoid, as mentioned previously. The control signals for these units are sent, together with the clock signal SIO CK and the strobe pulses SIO STB, from the servo system, then converted into serial signal SO 0. In the MD-43 board, this serial signal is converted into a parallel signal by IC501.

The reel brake plunger is controlled by the output from pins 5 and 6 of IC501. The other control signals are received in encoded form, hence they are decoded in IC502 then sent to each driver.

(A) Reel brake plunger drivers (MD-43 board)

There are two reel brake plunger drivers, one for the S reel brake and one for the T reel brake. The circuit configuration of both is the same, hence the following explanation is given using the S reel as an example. The reel brake plunger is pulled in two steps in order to reduce power consumption. When the signal that pulls the plunger from the servo system (pin 5 of IC501; when it is "H", the plunger will drawn in) is received, current flows into the base of Q510, causing Q510 to drive Q507. As a result, Q507 is turned ON, and the +14 V power supply voltage is supplied directly to the plunger. This condition is maintained for 0.3 seconds after the output of pin 5 of IC501 becomes "H". Subsequently, when C504 has charged sufficiently, Q506 supplies base current to Q507, causing a voltage which is just sufficient to hold the plunger in the retracted condition to be supplied to the plunger. The magnitude of this voltage is determined by the ratio between R516 and R517. At present it is set to about 6 V.

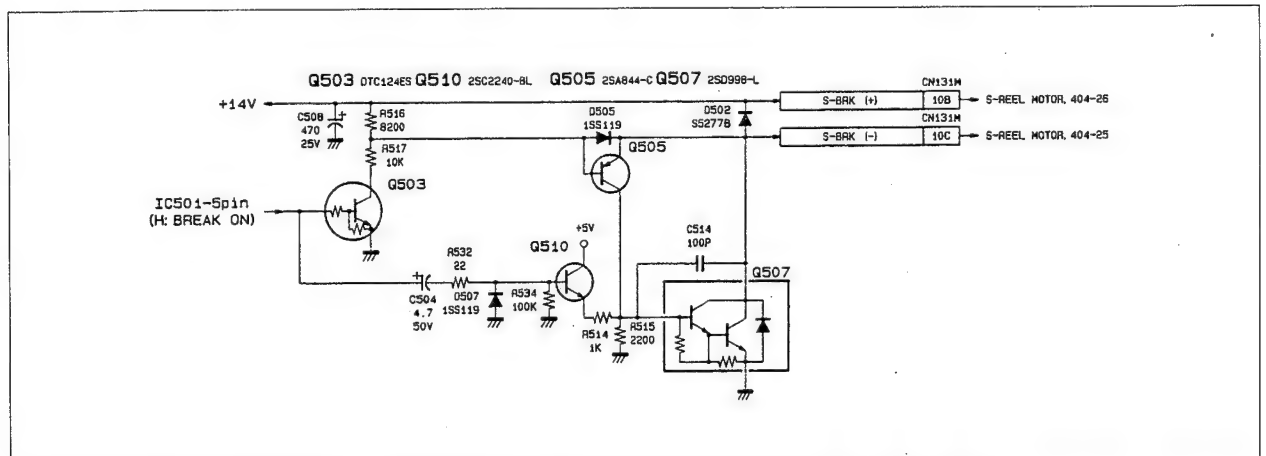

Fig. 4-6-9. Brake Plunger Driver (MD-43 Board)

(B) Motor driver (MD-43 board)

The drive circuit for all motors in the threading system are identical. As mentioned previously, the control signals for these motors are received in encoded form, hence they are first decoded by IC502 into signals for the respective drivers. The decoded control signals are sent to drivers IC504, IC506 and IC507 of the respective motors. These ICs are bridge type driver ICs which combine the IN1 (pin 1) and IN2 (pin 2) logic, enabling the motors connected to OUT1 (pin 3) and OUT2 (pin 5) to rotate in the forward or reverse direction.

To ensure that the threading operation takes place smoothly, the speed of each motor should be variable. To this end, this circuit is powered by a voltage from a variable output power supply. The LD CONT signal from the servo system controls the output of the power supply. The output of the power supply is supplied commonly to all of the drivers.

This produces the same results as independent power supplies because the control signal is encoded so that only one driver can be operated at any one time. In the MD-43 board, the motor supply current value is sensed by R530 as control information for when the servo system changes this output. This current is amplified to a suitable level (2 V/A) by IC505, then sent to the servo system.

(C) Pinch solenoid driver (MD-43 board)

Like the reel brake plunger, the pinch solenoid pulls the plunger in two stages. The configuration of the solenoid is different, however, so the circuit configuration is designed specifically to match it.

When pin 9 of IC502 is made "L" level to enable the servo system to pull the pinch solenoid, a signal which has been inverted by Q501 is input directly to the IN1 terminal (pin 1) of IC503, and the differentiated version of this signal is input to pin IN2 (pin 2). Initially, both inputs are "H" level, hence both OUT1 and 2 of the IC503 output are pulled to GND, and current flows into the winding which produces the greater pulling force. After about 0.6 seconds, the logic of the signal which passes through the differential circuit changes, hence OUT2 (pin 2) becomes "H" level (approx. +12 V), causing current to flow into the winding which produces the weaker pull force.

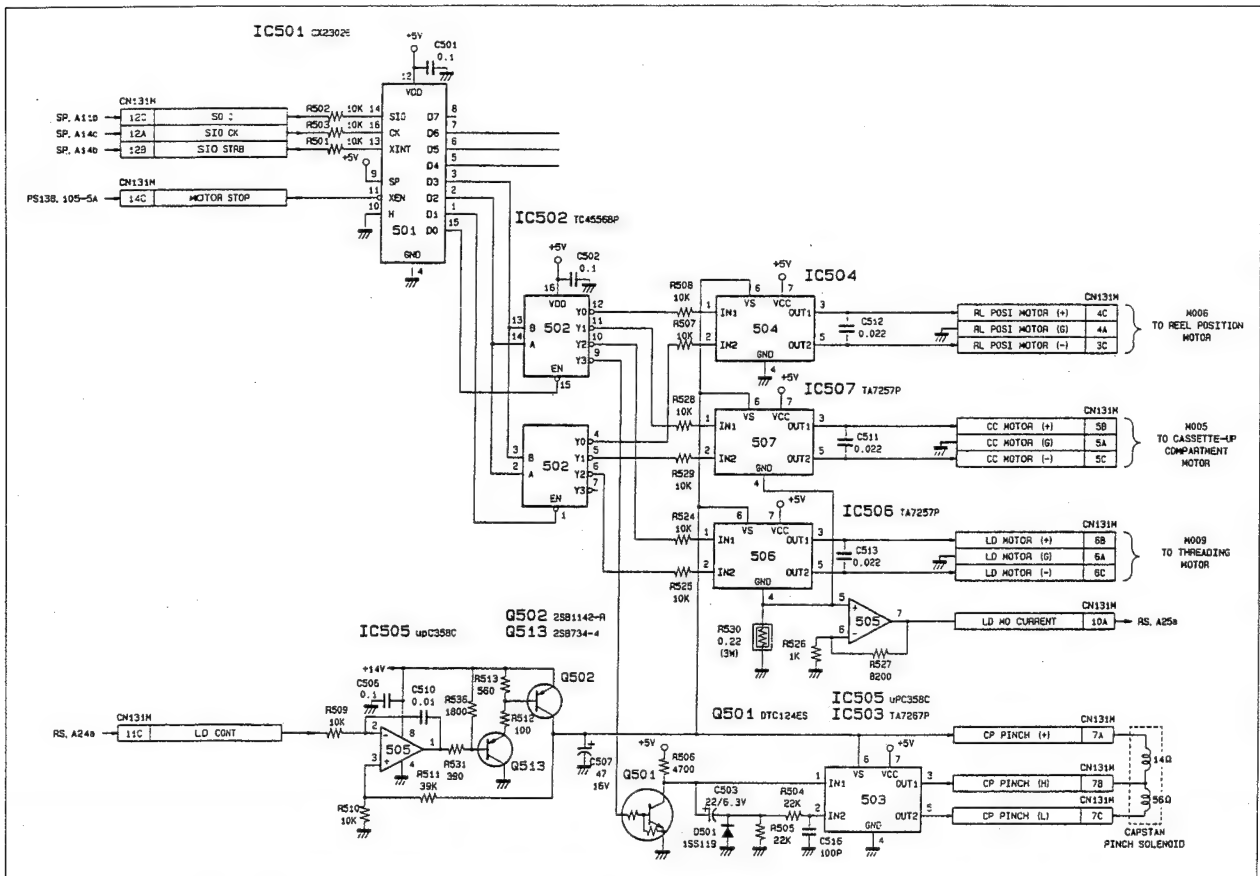

Fig. 4-6-10. Threading System Motor Driver and Pinch Solenoid Driver (MD-43 Board)

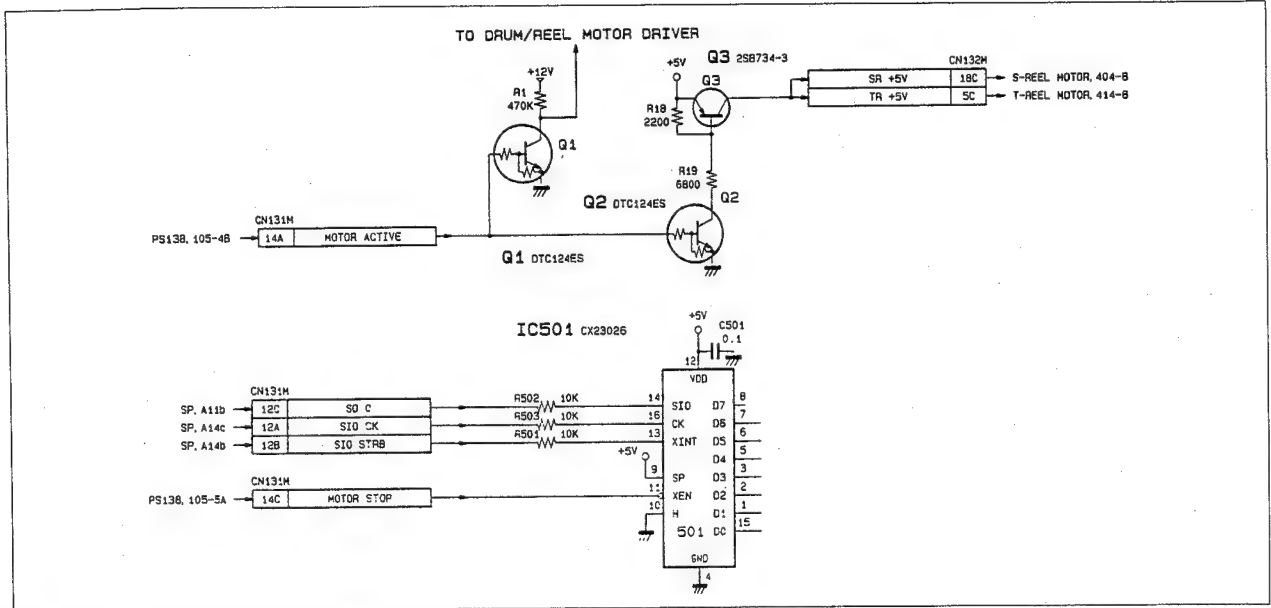

Fig. 4-6-11. Motor Stop Circuit (MD-43 Board)

5. Protection Circuit (MD-43 Board)

(A) Motor stop circuit (MD-43 board)

This circuit prevents the motor from rotating when the power is switched ON or OFF.

The MOTOR STOP signal and MOTOR ACTIVE signal are sent from the power supply section to the MD-43 board. These signals are basically one and the same. They are inverted before being sent, to facilitate processing in the MD-43 board, and also to prevent misoperation when the power is switched ON.

The power supply section supplies power to the servo/control system. After the lapse of a sufficient period to operate these boards, the logic of these signals changes, enabling the circuit in the board to operate.

(B) Motor overhear detection circuit (MD-43 board)

This circuit is designed to protect the motor in the event that the servo system or motor drive circuit breaks down.

The drum motor and reel motor contain diodes for sensing the temperature inside the motors. If a breakdown occurs, causing an excessively high current to flow through the motor, the internal temperature of the motor will rise, and the voltage drop across the diode will decrease.

In this circuit, this decrease is sensed by comparator IC3. The output from which is converted into a logic level and sent to the servo system and the power supply section. The logic level is inverted in the vicinity of 107°C to 217°C. If an overheat is detected, the power supply section cuts off the supply of power to the MD-43 board.

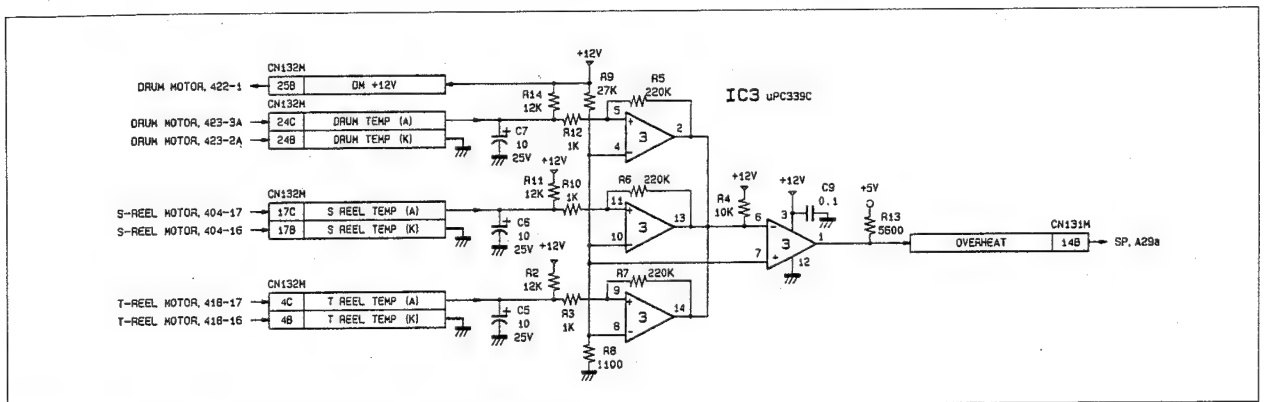

Fig. 4-6-12. Motor Overheat Detection Circuit (MD-43 Board)

(C) MD-43 board overheat detection circuit (MD-43 board)

This circuit is designed to protect the MD-43 board in the event that the fan motor stops or the load decreases.

Like the motors, temperature sensing is done utilizing the temperature dependence of the diode. Diode D1 which is in contact with the heat sink on the MD-43 board, detects the temperature of the heat sink. This diode is actually two diodes connected in series, resulting in a voltage change of double that of a single diode. In the servo system, this signal performs power saving and other functions.

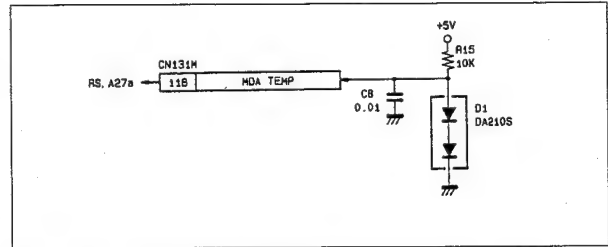

Fig. 4-6-13. MD-43 Board Overheat Detection Circuit (MD-43 Board)

4-4-7. PD-36 Board

On the scanner of the DVR-1000 are installed a recording amplifier and a playback amplifier. Power is supplied to these amplifiers via PRT (POWER ROTARY TRANS). The driver on the primary side is the PD-36 board.

Fig. 4-7-1. shows the circuit diagram of the PD-36 board. A 14 Vp-p square wave (50% duty) of frequency between 20 and 22 KHz is output from this board. The output current is a maximum of 1 A. Normally, however, about 300 mA is used.

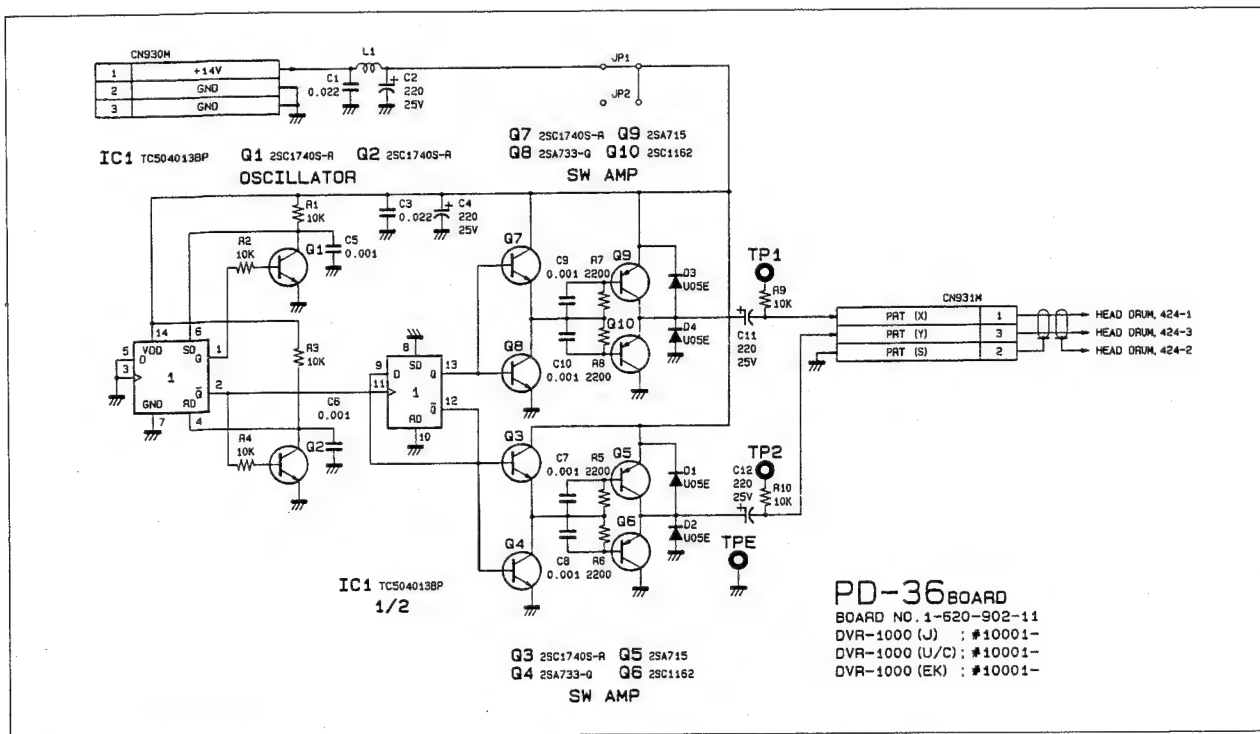

Fig. 4-7-1. PD-36 board

4-5. SYSTEM CONTROL SYSTEM

The SY-69 board in the system control system has been changed to the SY-124 board from the following serial numbers. The circuits of all these boards are virtually identical, hence only the SY-69 board is described.

DVR-1000(J): #21301 and Higher.
DVR-1000(UC): #11001 and Higher.
DVR-1000(EK): #11101 and Higher.

4-5-1. Outline of System Control System

The main features of the system control system are set out below.

(1) Full Graphic EL Display

The DVR-1000 has a graphic control panel which uses a 640 x 200 dot EL display. A menu is used for each function. The DVR-1000 also has such functions as multi cue and full graphic edit which could not be incorporated independently in VTRs up to now.

The control panel and the DVR-1000 proper are connected to each other by a single dedicated cable. The control panel can be removed from the DVR-1000, enabling it to be used as an independent remote controller.

(2) Menu Operation

The various settings of the DVR-1000, such as those for recording, playback and editing, can be set with menus.

Thus settings that on previous VTRs had to be performed using switches and potentiometers can be done entirely by software.

Settings can be made with the graphic display and cursor keys to simplify the work of making a large number of complicated settings. As a result, the number of operation buttons has been reduced to the minimum.

(3) Interface

RS422 PROTOCOL commands have been added/expanded, and almost all settings in the DVR-1000 can be made from external equipment. Provision has also been made for installing additional interfaces such as RS232C and PARALLEL I/O.

(4) Self Diagnosis Functions

The VTR has the following three self diagnosis functions. If an abnormality is found in the system, it will be displayed on the control panel. For details of error messages and their meanings, see the Operation Manual.

- Initial check of hardware
- Real time error check
- Warning for misoperation, etc.

A general description of the hardware and software in the system control system is given below. For details of the function control panel and the interface circuits, refer to sections 4-6. and 4-7..

4-5-2. Outline of Hardware

In the Sony 4:2:2 digital VTR system, the video and audio signals are processed in the DVPC-1000. The GPIB port functions as the interface between the system control system and the DVPC-1000. Consequently, the GPIB port cannot be used by the user.

The DVR-1000 interface system consists of the IF-138 board, IF-135 board, IF-134 board and PR-87 board.

The servo system and the system control system are interfaced by the SP-01 board, thus separating these two systems. This arrangement prevents a runaway from occurring in the tape transport system due to an external disturbance.

The system timing for all systems is controlled by the SP-01 board. The SY-69 board has overall control of the system control system. The control panel is controlled directly from the SY-69 board. The other external interfaces are controlled via the IF-138 board.

The IF-138 board contains NOVDRAM and HOURS METER circuits in addition to the interface circuit.

Fig. 5-2-1. shows the block diagram of the system control system.

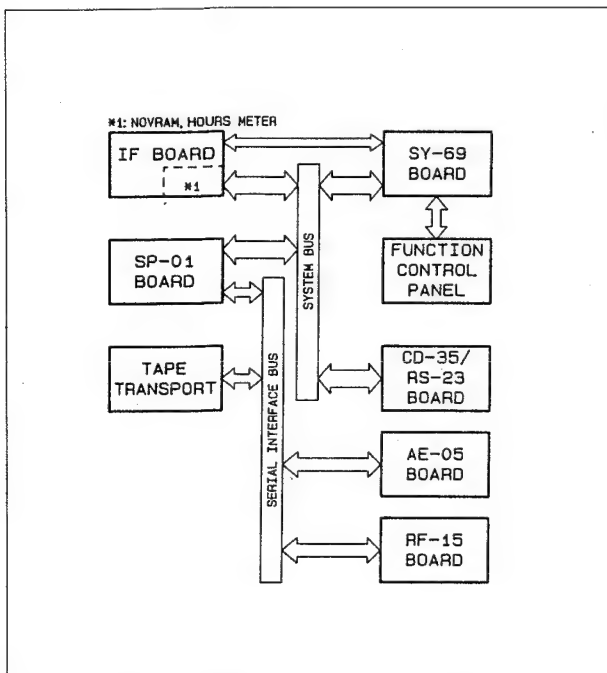

Fig. 5-2-1. Block Diagram of System Control System

4-5-3. Outline of Software

A description of the structure of the basic software pertaining to the BIOS-OS (operating system) is given below.

(A) SP-01 Board Software

The SP-01 board does not use an asynchronous interrupt. It runs only a minimum V/6 (525/60: 2.78 msec, 625/50: 3.33 msec) repetitive cycle interrupt routine. The circuit is designed so that all jobs executed in this interrupt routine are completed within this time slot and do not exceed this time under any circumstances whatsoever. If a job were to continue into the next time slot because of a breakdown, for example, the CPU would sense this, bring up a hard error flag, and stop all operations.

In addition to these V/6 period jobs, there are jobs that are executed at the main level. Such jobs are controlled in V units. They are classified into three kinds, those executed at intervals of V, those executed at intervals of 2V, and those executed at intervals of 4V. These three kinds of jobs are defined for each V, and are divided into a total of seven groups which are then controlled. Also, jobs that are executed at intervals of V/6 are divided into six groups, hence there are a total of 13 kinds of execution routine groups.

The V/6 timing signal is sent to each board in the servo system and also the SY-69 board. Interfacing with the SP-01 board takes place based on this timing. The FRAME signal that constitutes the source of the V/6 signal is generated by applying PLL using software to the FRAME signal received from the DVPC-1000. The difference in frequency between these two FRAME signals is controlled so that it is within $\pm 2\%$.

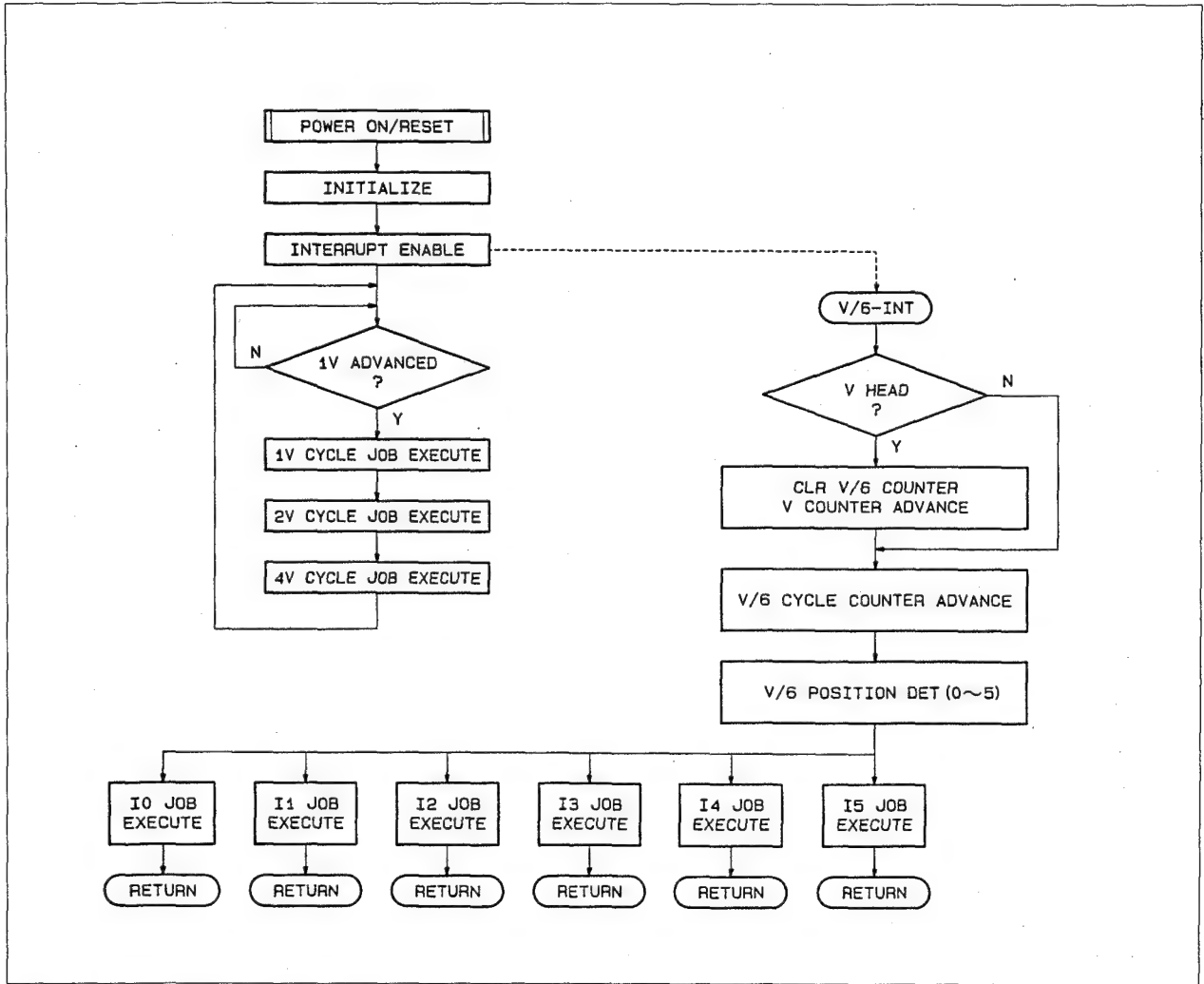

Fig. 5-3-1. Job Control Software Flow

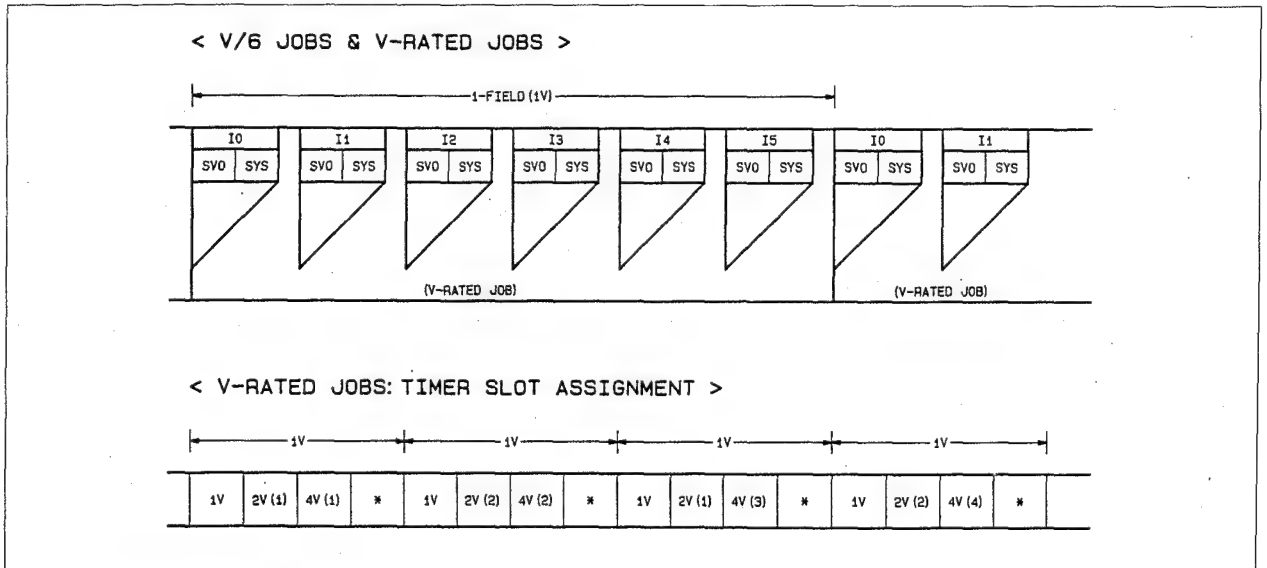

Fig. 5-3-2. Software Time Allocation

(B) SY-69 Board Software

The SY-69 board resembles the SP-01 board insofar as the V/6 signal received from the SP-01 constitutes the minimum unit for the job time slot. In the case of the SY-69, however, an asynchronous interrupt using an RS422 communications system is allowed, hence unlike the SP-01 board it cannot perform complete time control. The V/6 slot is allowed to be exceeded depending on the size of the interrupt from the RS422 communications system, or if there is mutual interference between the RS422 lines of the two channels.

Consequently, all jobs that require time control are processed at the beginning of the frame.

The priority sequence of interrupts is as follows:

1. TIME OUT
2. RS422
3. LTC
4. SY FRAME
5. V/6
6. SP-01 INTERFACE
7. GPIB

(C) Control Panel Software

The minimum job execution time slot is V. This matches the V signal that drives the EL display but is not synchronized with V generated in the SP-01 board.

Jobs related to the operation of the display all take place at the main level, and are processed at intervals of V. Key input processing and command processing take place at the interrupt level. Both processings are called at intervals of V.

In addition to the above interrupts, there are interrupts made to changes in the direction of rotation of the jog dial and interrupts made to the RS422 interface. The priority sequence of interrupts is as follows:

1. RS422
2. JOG DIAL DIRECTION CHANGE
3. V
4. TIME OUT

4-5-4. SY-69 Board

The SY-69 board consists of a CPU (V20: ICA4) and its peripheral circuits, external interface circuits, and a time code generator/reader.

The SY-124 board is used in DVR-1000 bearing the serial numbers shown below. The basic circuit configuration is the same as that of the SY-69 board, hence only the SY-69 board is described.

DVR-1000(J): #21301 and Higher.

DVR-1000(UC): #11001 and Higher.

DVR-1000(EK): #11101 and Higher.

1. CPU (SY-69 Board)

In the SY-69 board, a single CPU controls the various communications systems including the two asynchronous communications systems (RS422 and control panel), large capacity process synchronous communications system, and the GPIB, RS232C and parallel I/O, as well as the time code reader/generator. It is therefore necessary that the CPU be capable of processing at high speed and have a high processing capacity in order to minimize the prolonging in the synchronous system processing time due to processing in the asynchronous system. To this end, CPU ICA4 in the SY-69 board uses an internal 16-bit register/external 8-bit data bus V20 (μ PD70108; NEC). A 7.37 MHz clock is used for running CPU ICA4. This is 192 times (64×3) as fast as the 38.4 KBIT S/S, which is the transfer speed for on-off synchronous type RS422 serial communications.

2. Memory Access Space (SY-69 Board)

Fig. 5-4-1. shows the memory map of the SY-69 board. All of the devices are contained in the first 64 Kbytes of the 1Mbyte memory space that can be accessed by the CPU.

Consequently, address signals A16 to A19 are not used, and there is no need to perform segment control.

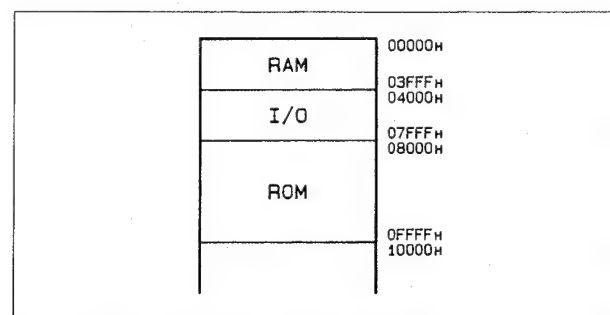

Fig. 5-4-1. Address Map (SY-69 Board)

(A) 0000_H to 03FFF_H: RAM area

The static RAM ICA10 is allocated to an area of 8 Kbytes starting from address 00000_H in the 16 Kbyte RAM area. The CPU interrupt vector area is allocated to the first 1 Kbyte (00000_H to 003FF_H), hence it is necessary to set the interrupt vector in the initial sequence after system is reset.

Sometimes it is more convenient to locate the vector area in the RAM rather than the ROM when carrying out processing after changing the jump destination by means of an interrupt. This is particularly useful when it is necessary to perform high speed processing such as RS422 asynchronous communications.

ICB1 and lithium battery BT1 hold the data in the RAM area after the power is switched OFF. In the case of the SY-69 board, however, the 4 Kbyte area subsequent to address 01000_H is used as a working area, and when the system is reset this area is cleared.

Chip selection in ICA10 is done by ICC4 which creates A14, A15, IO/M, as shown in Fig. 5-4-3. In an interrupt acknowledge sequence, it is necessary to prohibit access to the RAM while vectors are being written from the interrupt controller or SIO, hence A14, A15 is passed through an AND gate with INTA or IO/M.

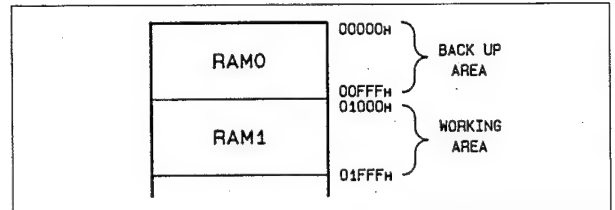

Fig. 5-4-2. RAM Area (SY-69 Board)

(B) 04000_H to 07FFF_H: I/O area (SY-69 board)

A memory mapped I/O method is used in consideration of the degree of freedom of programming. Fig. 5-4-4. shows the memory map in the I/O area.

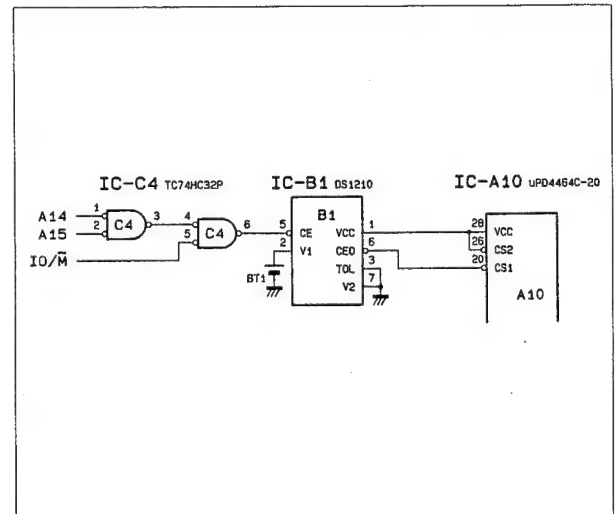

Fig. 5-4-3. RAM Address Decoder (SY-69 Board)

(C) 08000_H to 0FFFF_H: ROM area (SY-69 board)

ROM ICA9 is allocated to 32 bytes starting from 08000_H. The reasons for locating the ROM in this area are as follows:

- The CPU starts from address FFFF0_H after being reset.
- It is more convenient from the viewpoint of asynchronous communications to locate the RAM rather than the ROM in the interrupt vector area.
- Address decoding can be done easily by allocating the 32 Kbytes continuously.

Chip selection in ICA9 is done by passing A15 and INTA through a NAND gate (ICD15). In an interrupt acknowledge sequence, it is necessary to prohibit access to the ROM while vectors are being written from the interrupt controller or SIO, hence it is necessary to pass A15 together with INTA or IO/M through a NAND gate. If IO/M were to be combined with A15, it would be necessary to invert IO/M, hence INTA is used here.

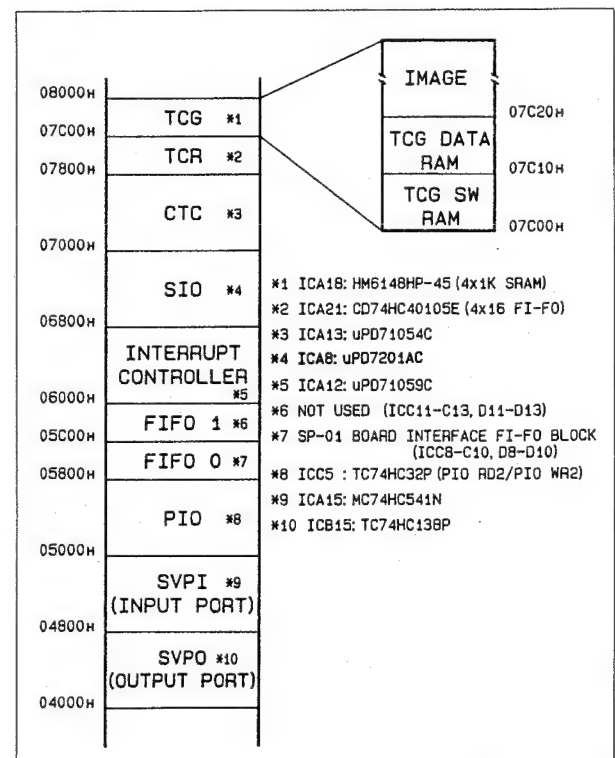

Fig. 5-4-4. I/O Area (SY-69 Board)



3. CPU Peripheral Circuit and Interface Circuit (SY-69 Board)

This block consists of CPU peripheral circuits including a ROM, RAM, interrupt controller, and address decoder, an external interface circuit which performs communication with the RS422, GPIB, and control panel, and an internal interface circuit which performs communication with the SP-01 board and the IF-138 board.

The CPU analyses the various control commands received from outside, then sends commands to the servo system and processor (DVPC-1000), and also re-transmits data from the servo system and the processor to outside. This block also performs timing control during editing, processes macro commands in the AUTO EDIT and preview modes, and performs intelligent processing such as player control.

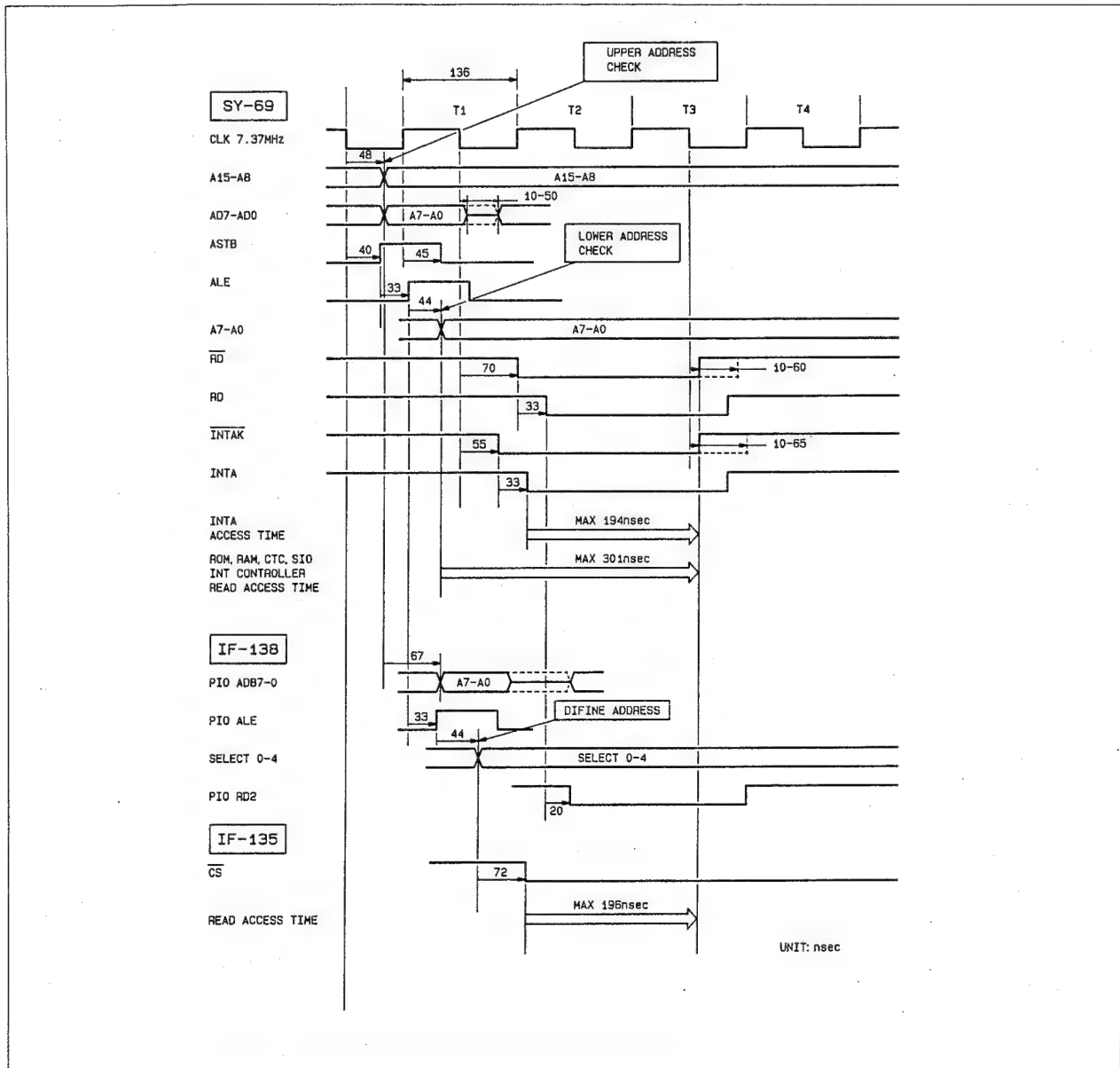

Fig. 5-4-5. Timing of Interface between CPU and Peripheral Boards (SY-69)

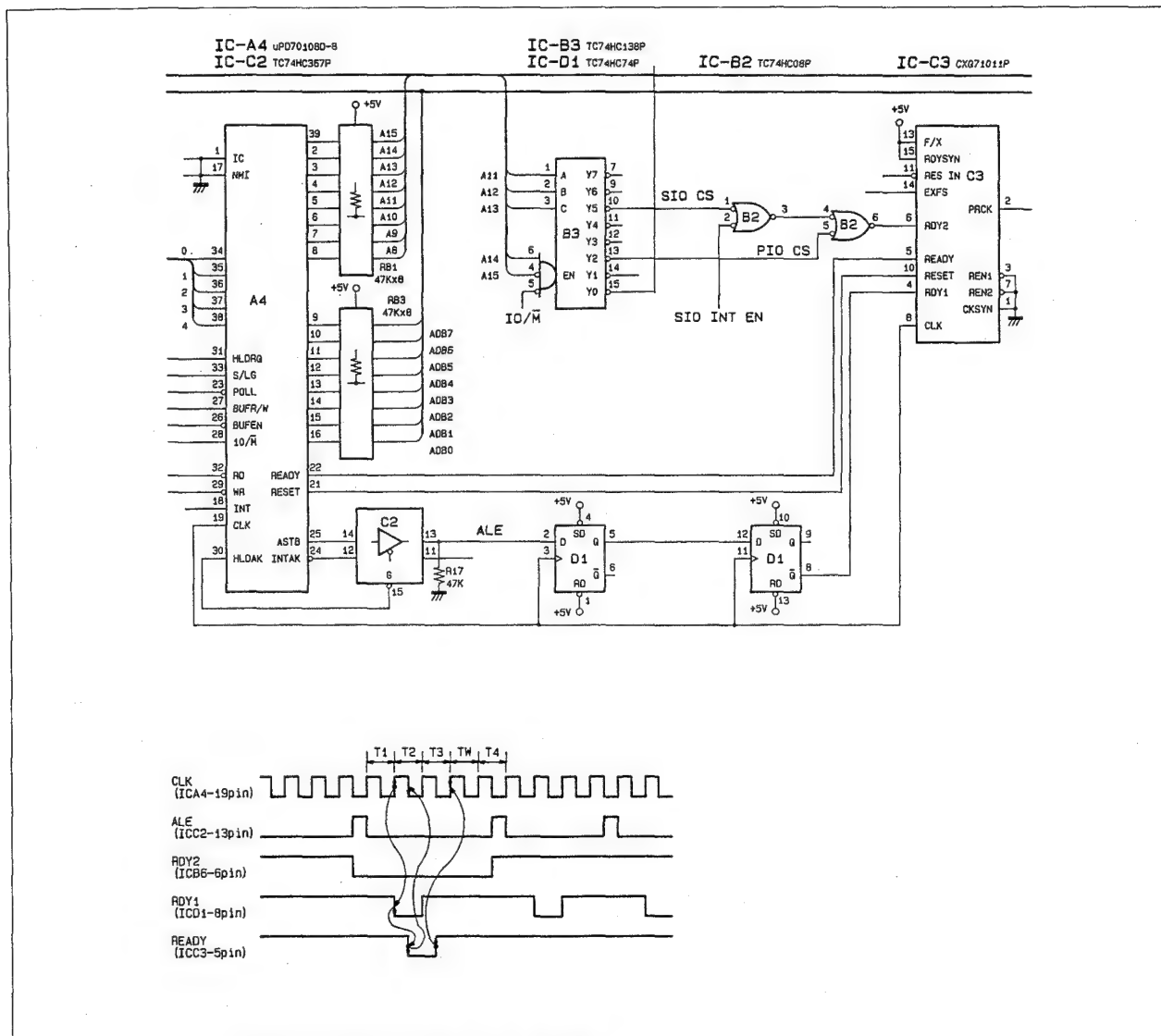

Fig. 5-4-6. CPU READY Pulse Generator Circuit (SY-69 Board)

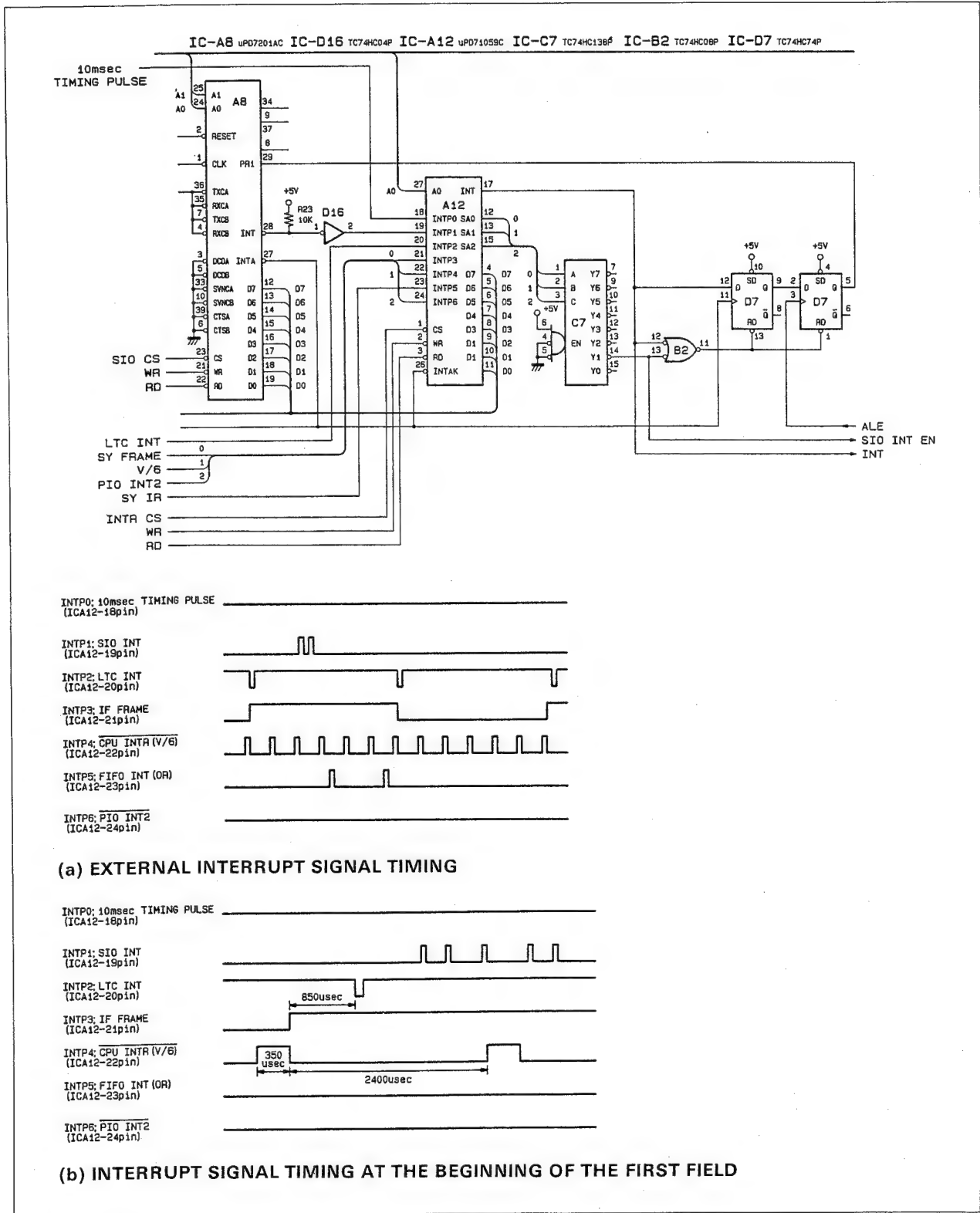

Fig. 5-4-7. Interrupt Controller (SY-69 Board)

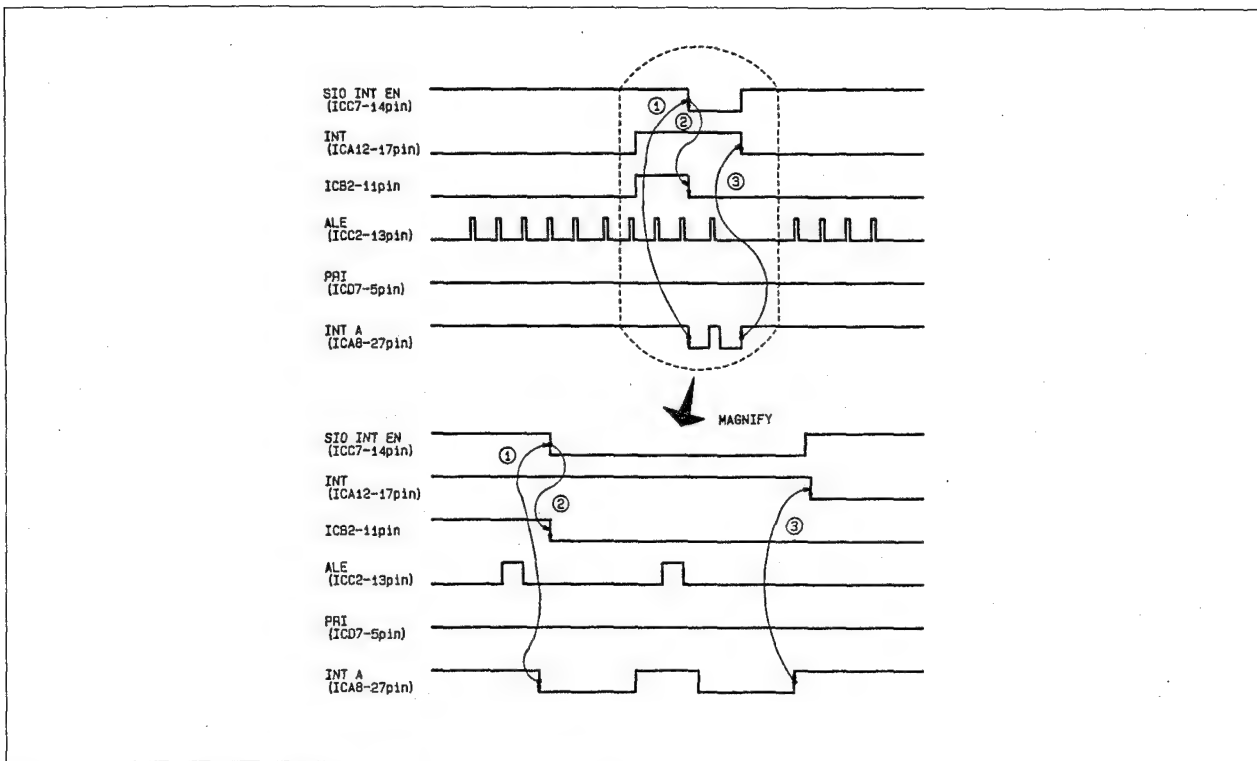

Fig. 5-4-8. SIO Interrupt Sequence (PRI = "Low" SY-69 Board)

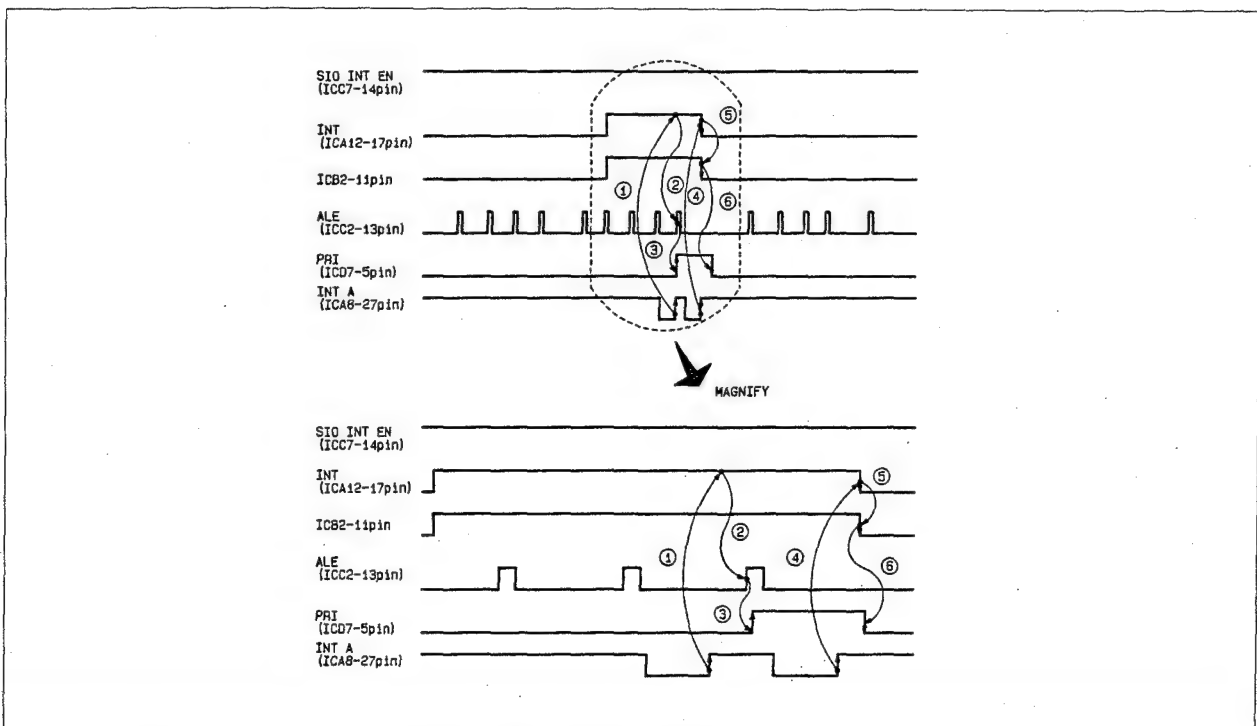

Fig. 5-4-9. Interrupt Sequence other than for SIO (PRI = "High" SY-69 Board)

4. Time Code Generator/Reader (SY-69 Board)

This block consists of ICB20 (time code reader), ICB17 (time code generator) and a CPU interface circuit. It reads and generates time codes, and slave-locks onto external time codes.

The time code generator contains a phase shift circuit which uses a CTC, enabling the position of the start bit for recording/playback of a time code to be set arbitrarily according to the delay which arises in the digital process.

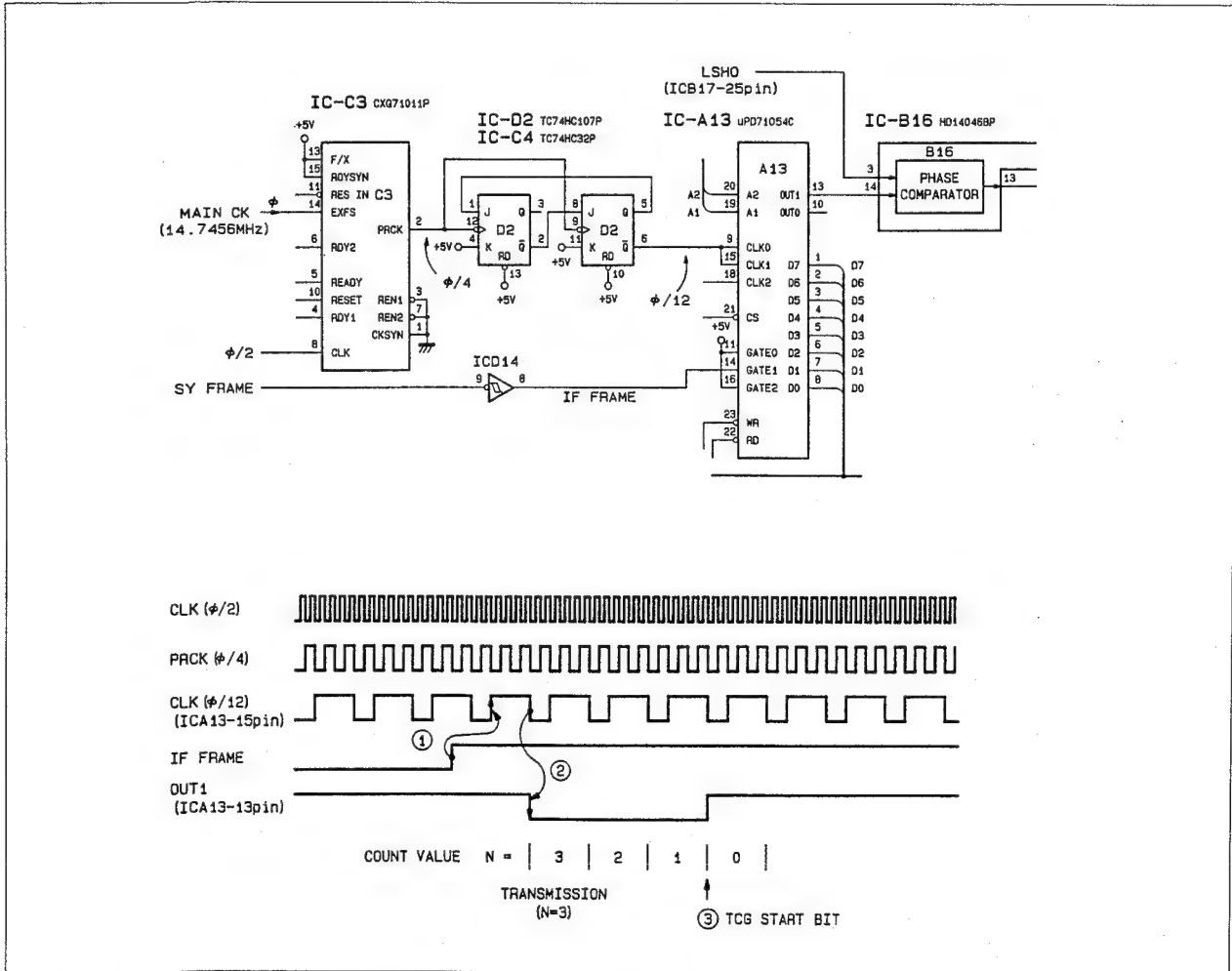

Fig. 5-4-10. Time Code Generator Phase Shift Circuit (SY-69 Board)

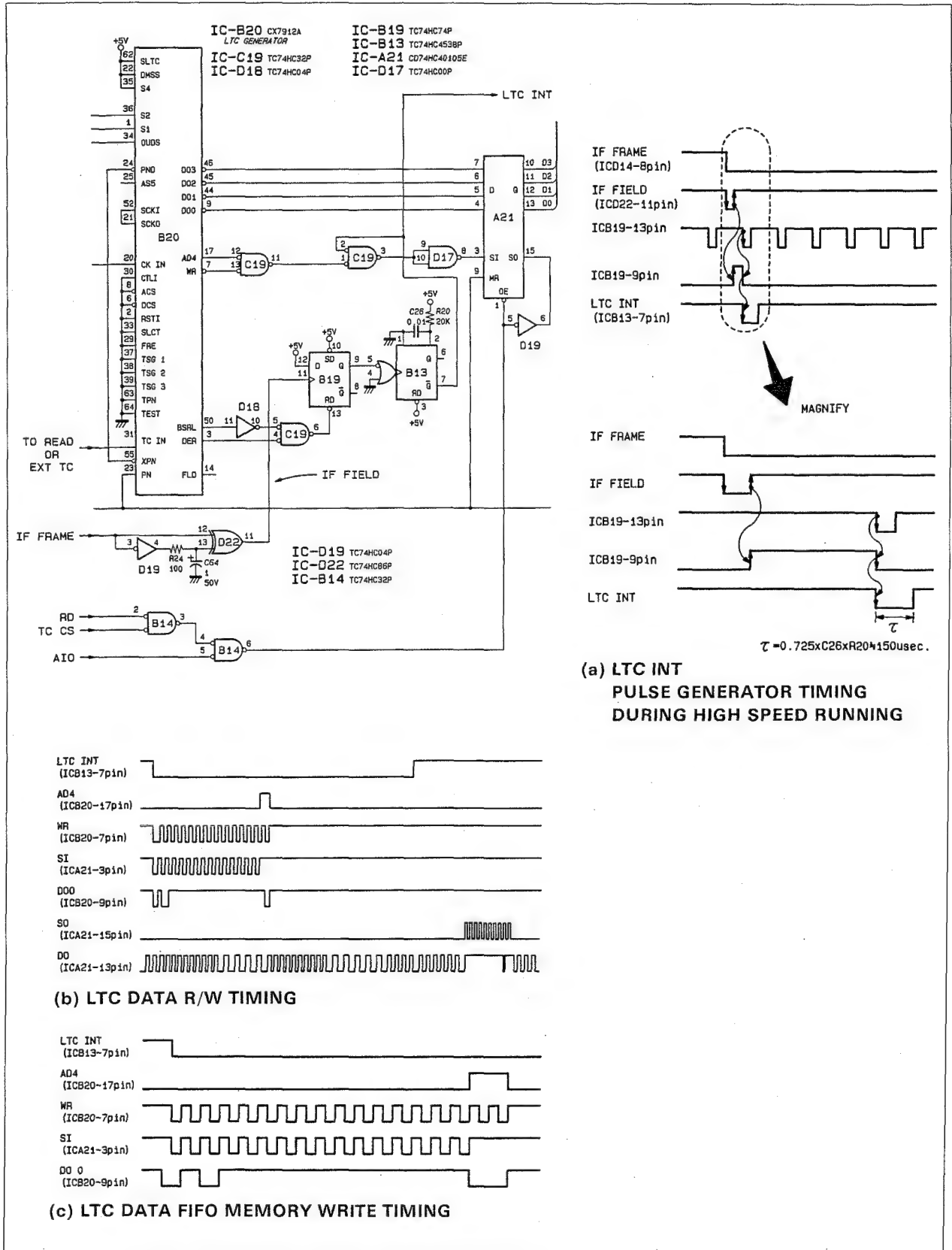

Fig. 5-4-11. LTC Read Interrupt Pulse Generator Circuit (SY-69 Board)



4-6. FUNCTION CONTROL PANEL

4-6-1. CP-106 Board

The CP-106 board is the main control board of the function control panel. It consists of the following circuits.

- CPU (IC15)

The CPU has a 16-bit internal register and an external 8-bit data bus.
- PROM (IC7, 13 and 14)

Three 512 Kbit PROM are used.
- RAM (IC6)

The RAM has a capacity of 64 Kbits. The data are backed up by a backup controller IC12 and a lithium battery.
- Graphic display controller (GDC: IC9, 10, 11, and 19)
- Interrupt controller (INTC: IC1)
- Counter timer (CTC: IC2)
- Serial I/O (SIO: IC8)

The memory and peripheral ICs all consist of a memory mapped I/O format. They are arranged as shown in Fig. 6-1-1.

PROM IC7 is assigned to addresses FFF80_H and above. The CPU reset start address FFFF0_H is included in these addresses. The RAM and I/O area are located in E000_H and above in each segment.

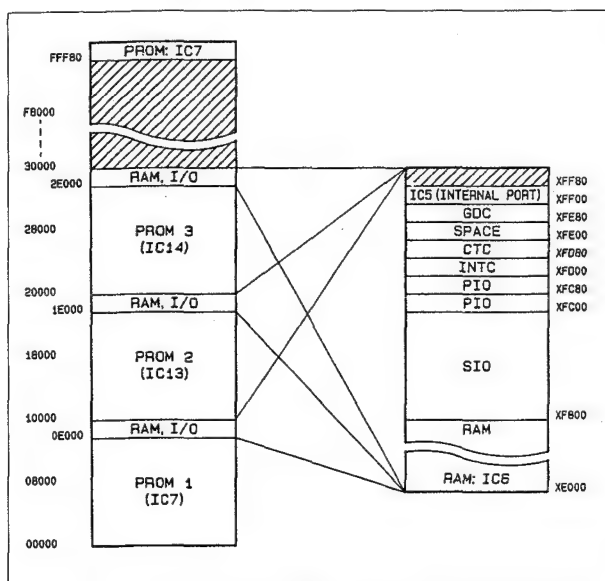

Fig. 6-1-1. Memory Map (CP-106 Board)

1. +5 V Monitor Circuit (IC3/CP-106 Board)

This is the +5 V power supply system monitor circuit. If the power supply voltage drops below 4.7 to 4.8 V, the monitor circuit makes the RESET active and holds it for about 500 msec. It also outputs a 500 msec RESET pulse in the event of a momentary power failure, preventing a runaway of the program due to a power supply abnormality.

2. Clock Generator (IC4/CP-106 Board)

IC4 is the CPU clock generator. It sends a 7.3728 MHz system clock to CPU IC15. It also synchronizes the asynchronous RESET and WAIT signals received from outside with the internal clock, and sends them to the CPU. A 14.7456 MHz clock is supplied to the EXFS terminal (pin 15) of IC4.

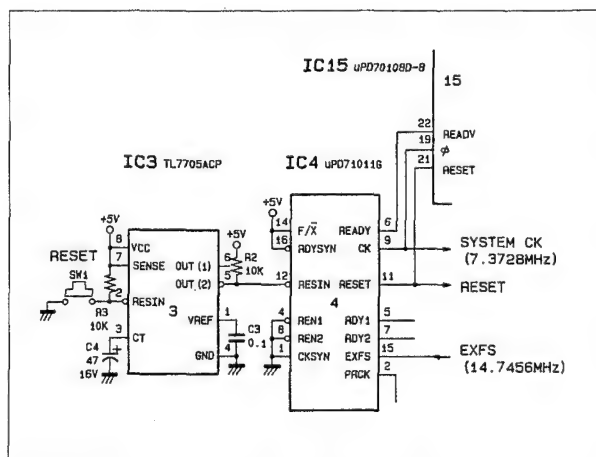

Fig. 6-1-2. +5 V Monitor/Clock Generator (CP-106 Board)

3. Peripheral Interface (IC5/CP-106 Board)

Normally, the gates located in the vicinity of the CPU are contained in an 80-pin mini-flat package gate array for reduced space, reduced power consumption and high speed operation. IC5 consists of the following circuits.

- An address decoder for creating chip select signals for the RAM, ROM and other ICs in the vicinity of the CPU.
- A circuit which generates an address signal from the data/address time shared bus
- An output port
- A reset signal inversion circuit
- A gate which makes all of the display data sent to the EL display "0"
- A circuit which controls the jog dial and rotary encoder for the CTC
- An SIO interrupt interface
- A clock frequency divider circuit
- A circuit which senses changes in the direction signal from the jog dial and sends an interrupt to the CPU

4. Data Backup Control Circuit (IC12, BATT/CP-106 Board)

The backup controller IC12 controls the chip select terminal and the V_{DD} terminal. It prohibits access to the RAM when the power supply voltage falls to about 4.25 to 4.5 V, thus protecting the data in the event of voltage drop. If the voltage drops further, current is supplied from a lithium battery. When the power is switched ON, the condition of the lithium battery is checked, and if the output voltage has dropped, an alarm indication appears.

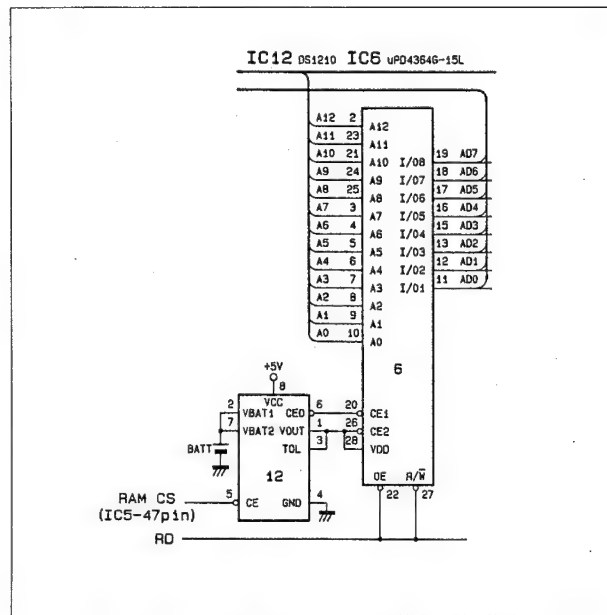

Fig. 6-1-3. Data Backup Control Circuit (CP-106 Board)

5. Timer Counter (IC2/CP-106 Board)

The timer counter IC2 uses μ PD71054 (NEC) which contains three timers/counters. Counter No.0 detects an RS422 communication time-out and applies an interrupt to the CPU. Counters No.2 and No.3 operate as jog dial and rotary encoder pulse counters, respectively.

6. Interrupt Controller (IC1/CP-106 Board)

The interrupt controller IC1 uses a μ PD71059 (NEC) which has eight interrupt inputs. In actual fact, only the following four inputs are used.

The priority sequence of the interrupts is INTP1 \rightarrow INTP5 \rightarrow INTP6 \rightarrow INTP0. Also, terminals SA0 to SA2 are used for making connection to a serial interface.

- INTP0: Interrupt signal generated in event of RS422 time-out
- INTP1: Interrupt signal for serial interface
- INTP5: Interrupt signal generated when direction of rotation of jog dial is changed
- INTP6: Vertical sync pulses output from graphic display controller are input, and used to trigger the internal program.

7. Serial Interface (IC8/CP-106 Board)

The serial interface IC8 (μ PD7201, NEC) contains sending and receiving circuits for two independent channels. Here, only the A channel is used.

The clock supplied for communication is 1.2288 MHz. This is frequency-divided internally to 1/32, which is suitable for 38.4 K baud. This IC outputs a vector during a communication interrupt. The PRI terminal (pin 29) is used to prevent this vector from competing with the interrupt controller.

8. EL Display Controller (IC9, 10, 11, 19/CP-106 Board)

This circuit accesses RAMs IC11 and 19 according to commands and data received from the CPU, and sends display signals to the EL display unit.

The various parameters such as the horizontal/vertical sync period for the display, the number of line/row display dots, and the front/back porch can be set arbitrarily. The clock used to operate this circuit is 7.3728 MHz.

Data exchange between RAMs IC11 and IC19 uses a 16-bit bus. It takes 543 nsec to re-write 16-dots on the EL display, and at least 70 msec to re-write 640 x 200 dots.

Data is written to the RAM, one dot of the EL display corresponding to one bit. The character font is stored in a PROM. It is sent to this circuit via the CPU.

4-6-2. SW-157 Board (SW-158 Board)

The SW-157 board consists of two gate arrays which have 36 I/O terminals, a sound generator, RS422 driver/receiver, jog dial/rotary encoder interface, and also switches and LEDs. The SW-158 board consists of switches.

1. I/O Ports (IC3, 5/SW-157 Board)

The I/O port uses a CXD1095 (SONY) which has 36 I/O terminals. This IC does not have a function that makes all ports high impedance in the event of a power-on reset, hence IC9 has been added.

PA0 to PA7 and PB0 to PB7 of IC5 are used as switch interfaces on the SW-157/SW-158/PS-139 boards. By designating the row to be sensed by PB0 to PB7, the bit corresponding to the switch pressed will be returned as "1" from PA0 to PA7. PC3 to PC6, PD0 to PD7, and PX0 to PX3 of IC5, and also PA0 to PA7 and PB0 to PB7 of IC3 absorb the drive current of the LEDs directly. However, the STOP/PLAY/REC buttons have two or four LEDs connected in parallel, hence digital transistors Q1 to Q3 are used. These buttons are driven by +15 V through the digital transistors.

2. Programmable Sound Generator (IC1, 3/SW-157 Board)

PC0 to PC7 and PA0 of IC3 control the program sound generator IC1. The inside of IC1 consists of three frequency divider circuits, each of which has a 16-step attenuator, and also a noise generator. The signal output from IC1 is voltage-divided by R9 and R11, amplified by approx. 40 dB by IC2, and output from a micro-speaker.

Compared to a piezo electric buzzer which is generally used, this micro-speaker has a wide frequency response and enables the sound to be varied.

4-6-3. PS-139 Board

This board converts the +22 V power supply voltage from the DVR-1000 into +5 V and +15 V. It consists of a switching regulator that supplies these voltages to the various boards, as well as switches, LEDs and a connector for interfacing with the DVR-1000.

1. Switching Regulator (IC1 to 4, Q1 to 4/PS-139 Board)

The +5 V and +15 V power supply systems both have roughly the same circuit configurations. Accordingly, a description of the +5 V system is given below.

The +22 V supplied from the DVR-1000 rises relatively slowly, and when it exceeds the zener voltage of diode D2, that

is 13 V, switching takes place. The +15 V system uses diode D3 which has a zener voltage of 16 V, hence the +5 V system starts up first.

The output (pins 8 and 11) of PWM controller IC3 passes through driver IC4, and is then sent to switching FET Q2, causing the +22 V from the DVR-1000 to be switched. The switched signal is smoothed by D4, L3 and C12, then sent to each board as the +5 V power supply voltage. This +5 V is also sent to the two error amplifiers in IC3. The error amplifier which has the IN1 ± (pins 1 and 2) input monitors voltage, and the error amplifier which has the IN2 ± (pins 15 and 16) input monitors current.

The output voltage is adjusted by RV3, and the limit value of the output current is adjusted by RV4.

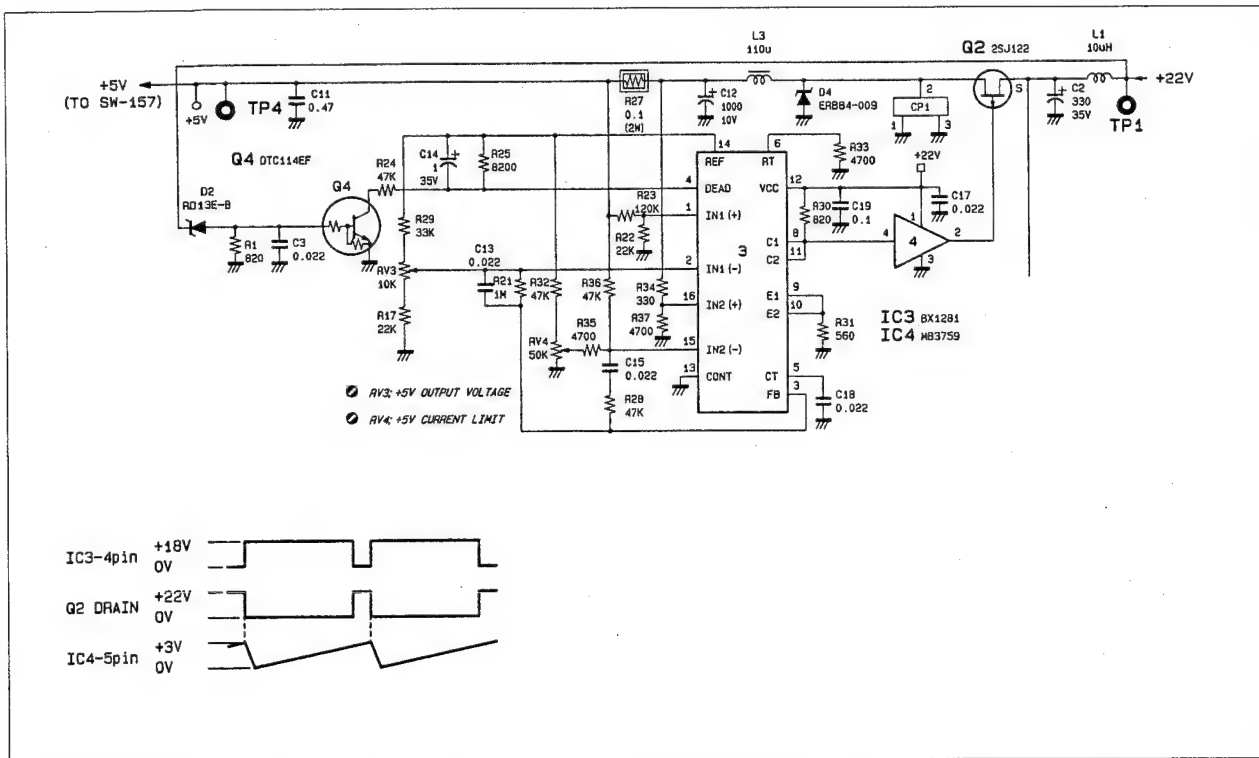

Fig. 6-3-1. +5 V System Switching Regulator (PS-139 Board)

4-6-4. EL Display Unit

This is an orange-yellow monochrome single tone graphical display. Data "EL DATA", dot clock "DOT CLK", horizontal sync signal "HD", and vertical sync signal "VD" are input to this unit at TTL level. DOT CLK is 14.7456 MHz, HD is 13.5KHz, and VD is 62 Hz.

This unit draws 450 mA (max) from the +5 V system, and 600mA (max) from the +15 V system.

This unit is intended to be replaced as a block. Also, it contains a high voltage section, so never disassemble it.

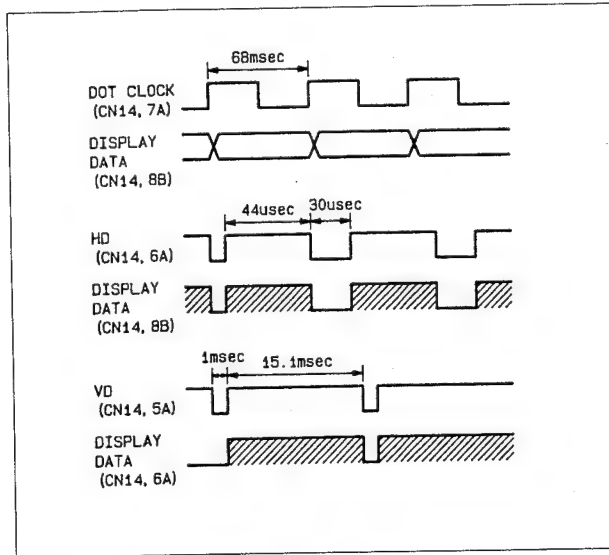

Fig. 6-4-1. Timing Chart (EL Display)

4-6-5. Jog Dial (DET-3 Board)

This board consists of a DME which picks up pulses from the search dial, a wave-shaping circuit, and also a circuit which transfers current to the clutch.

72 pulses of a 2-phase signal are output for each rotation of the jog dial.

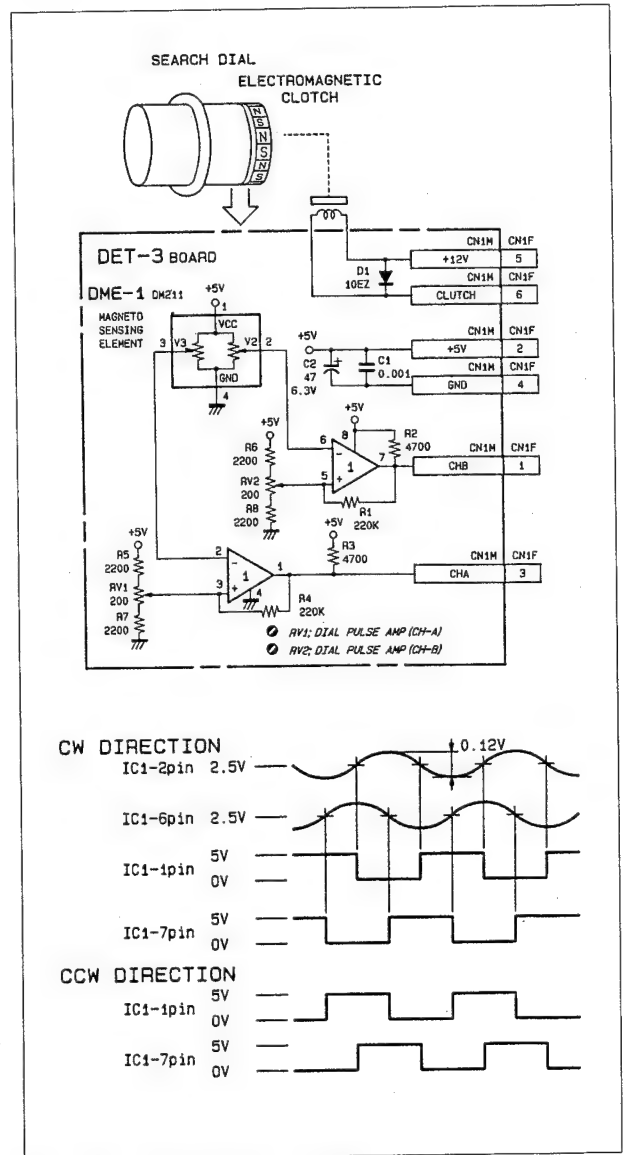

Fig. 6-5-1. Jog Dial (DET-3 Board)

4-6-6. Rotary Encoder (RE-44 Board)

The rotary encoder outputs 100 pulses of a 2-phase signal for each rotation. The inside of the encoder consists of a light emitting section which uses an LED, a light receiving section which uses a phototransistor, and two slots. The output from the encoder is wave-shaped by the RE-44 board, then output. RV1 and RV2 on the RE-44 board are potentiometers which are used to set the threshold voltage of the A and B channels, respectively. This enables the duty of the output signal to be changed. The hysteresis is 0.26 V.

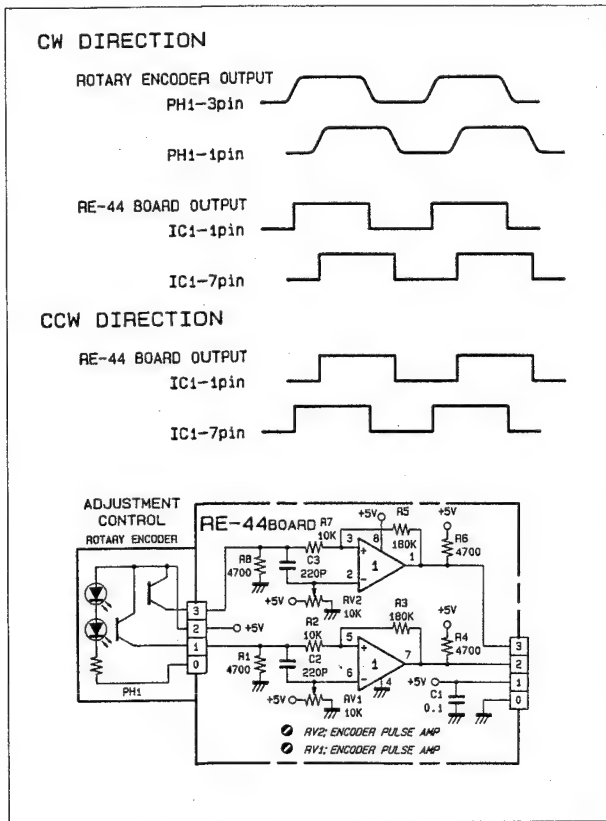

Fig. 6-6-1. Timing Chart (RE-44 Board/Rotary Encoder)

4-6-7. Self Diagnosis When The Power is Switched ON

The following hardware checks are performed by the function control panel when the power is switched ON, in order to warn the operator of any trouble. If trouble is detected, the kind of trouble is displayed. The hardware checks are performed in the following sequence.

(1) Battery Check

Indication: "BATTERY EMPTY"

Meaning: The backup controller (IC12/CP-106) contains a comparator which has a battery input. If the battery voltage is normal, the first and second RAM write operations will take place correctly after the power is switched ON. However, if the voltage drops, the second write operation will be ignored. This function is utilized to check the battery voltage.

(2) Backup Data Check

Indication: "BACKUP DATA LOST"

Meaning: Two bytes data called AA55_H is written to four points on the RAM (IC6/CP-103). It detects an error in the event that the data in this area is re-written as a result of a momentary failure of the backup battery or a runaway of the program.

(3) RAM Read/Write Error

Indication: "RAM (CP106, IC6) ERROR"

Meaning: Two-byte data called 5555_H is written to all areas in the RAM. This data is then read to judge the integrity of the RAM.

(4) PIO Check

Indication: "PIO (SW157, IC3) ERROR"

"PIO2 (SW157, IC5) ERROR"

Meaning: One byte of data called 55_H or AA_H is written to PIO (IC3, 5/SW-157). This data is then read to sense any errors.

(5) CTC Check

Indication: "CTC (CP106, IC2) ERROR"

Meaning: One byte of data called 55_H or AA_H is written to the CTC (counter timer). This data is then read to sense any errors.

(6) INTC Check

Indication: "INTC (CP106, IC1) ERROR"

Meaning: The same check as the CTC check is performed on the INTC (interrupt controller).

(7) SIO Check

Indication: SIO (CP106, IC8) ERROR

Meaning: After initialization, the vector is read to see whether or not it is the written data ("6C_H").

(8) Key Short Check

Indication: "KEY SHORT ERROR"

Meaning: A check is performed to see whether or not the key switch is shorted.

The power-on check sequence of the function control panel is an internal self-completion type, hence if an error occurs in the circuit that drives the display, the above messages will not appear. To overcome this, there is also a check method which enables the internal condition of the control panel to be known.

When the power is switched ON, the following indications appear on the display. Here, (X) indicates the sequence number.

Indication: (X) INITIAL

keep off all the control

X=0: Initialization of the display has started.

X=4: Initialization of the RAM has started.

X=5: Initialization of the CTC has started.

X=6: Initialization of the INTC has started.

X=8: A short check of KEY has started.

3
7
11
15
19
23
27
31
35
39
43
47
51
55
59
63
67
71
75
79
83
87
91
95
99

4-7. INTERFACE SYSTEM

The interface system of the DVR-1000 consists of the IF-134, IF-135 and IF-138 boards, and also the PR-87 board.

4-7-1. IF-138 Board

The IF-138 board consists of interface circuit for the interface boards (GPIB: IF-135 and RS422: IF-134) and the SY-69 board, a NOVRAM, and a maintenance timer circuit.

1. NOVRAM (IC5, 6/IF-138 Board)

This board consists of two NONVOLATILE RAMs (NOVRAMs). The NOVRAMS are controlled by the SP-01 board. The following control signals are supplied from the SP-01 board.

- SVD0 to SVD7
- SV ALE
- NOV WR
- NOV CS
- NOV RECALL
- NOV STORE
- PIO RD1

The PIO RD1 is shared with the maintenance timer circuit which is described later. SVD0 to SVD7 are buses that are used for both data and addresses. Addresses and data are separated by IC2 and 3.

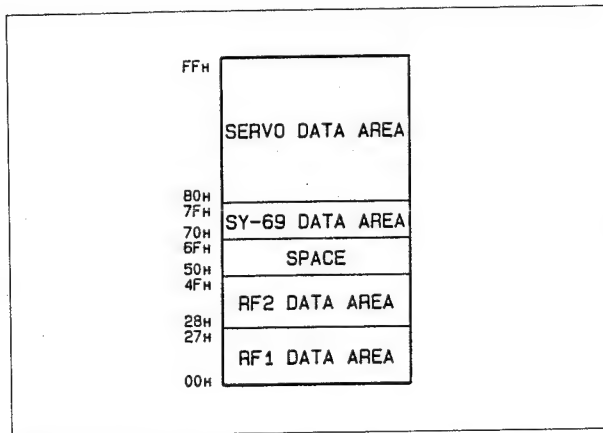

Fig. 7-1-1. NOVRAM Address Map (IF-138 Board)

2. Maintenance Timer (IC7, 8, 9/IF-138 Board)

IC9, which is used as a maintenance timer, contains four kinds of timer software. It exchanges data with the CPU of the SP-01 board by handshaking via IC7 (IF-138→CPU) and IC8(CPU→IF-138).

Data from the CPU are input to input ports P40 to P43 and P50 of IC9. P52 and P53 are the input handshake lines. Data to the CPU are output from output ports P20 to P23. P63 is the output handshake line.

A double data backup consisting of capacitor C8 and a lithium battery is used. During normal use, the power is off for relatively short periods, and the data is backed up by the capacitor, hence the lithium battery is not discharged. The lithium battery is discharged when the power remains off continuously for several days and the backup voltage of the capacitor falls below 3 V.

Transistor Q1 is used to pull IC9 into the standby mode (backup mode). When the power is switched ON, IC9 reset pulses are generated from the PIO RESET pulses, causing the system to leave the standby mode.

An oscillator circuit that generates a frequency of 32.768 KHz is installed for measuring time.

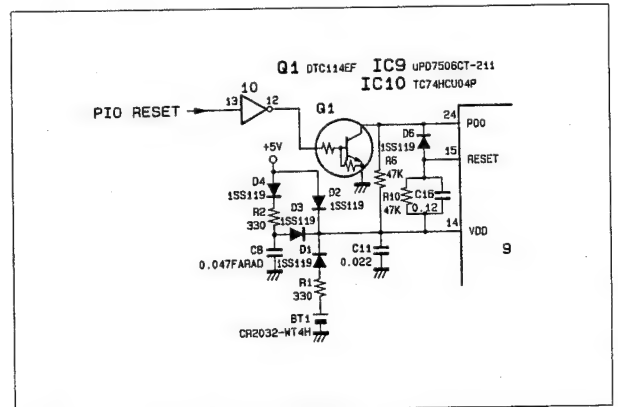

Fig. 7-1-2. Backup Circuit (IF-138 Board)

3. Interface Circuit (IF-138 Board)

The interface system is controlled by the SY-69 board. The following signals are supplied from the SY-69 board.

- PIO ADB0 to PIO ADB7
- PIO RD2
- PIO WR2
- PIO ALE
- PIO CK
- PIO INT2

PIO ADB0 to 7 are buses that are used for both data and addresses. Data and addresses are separated by IC1 and IC4, and sent to each interface board. Other signals are sent directly to the interface boards.

4-7-2. GPIB Interface (IF-135 Board)

The GPIB port is installed for interfacing with the DVPC-1000 processor.

At the address decoder IC2, SELECT0 to 4 which are received from the IF-138 board are converted into the two select signals for GPIB. The output from pin 5 of IC2 is used as a chip select signal for the GPIB controller IC3. The other select signal is output from pin 4 of IC2, enabling IC4 which sends the hardware ID (=03_H) of the IF-135 board to be accessed. IC4 and IC6 are the bus buffers of GPIB.

4-7-3. RS422 Interface (IF-134 Board)

The address decoder IC5 decodes SELECT0 to 4 which are received from the IF-138 board, and outputs the following two select signals.

A signal which accesses port IC3 that selects the mode of the three 9-pin RS422 connectors on this board is output from pin 11 of IC5. Also, a signal which accesses IC4 that sends the hardware ID (=00_H) of the IF-134 board is output from pin 12 of IC5. The mode select port IC3 is initialized when the power is switched ON and also by the reset signal from the SP-01 board.

4-7-4. PR-87 Board

This is an interface board for signals transferred between the DVR-1000 and the DVPC-1000 via the D-SUB 50-pin connector. The input and output signals are all at differential levels.

The following signals are sent from the DVPC-1000 to the DVR-1000.

- REC1 to REC4: Recording RF signal
- FRP: Reference frame signal
- AFP: Reference audio frame signal
- CFP: Reference color frame signal
- DFP: Drum reference signal
- AU R, AU L: Digital audio monitor signal
- DMIX: Digital mix signal

The following signals are sent from the DVR-1000 to the DVPC-1000.

- PB1 to PB4: Playback RF signal
- AFT: Audio frame signal separated from the playback CTL signal (or frame signal separated from the playback CTL signal, in the case of a 625/50 system)
- CFT: Color frame signal separated from the playback CTL signal

1. RF Signal (PR-87 Board)

The recording RF signal from the DVPC-1000 is sent to the RF-15 board via this board. Conversely, the playback RF signal from the RF-15 board is sent to the DVPC-1000 via this board.

2. Digital Audio Monitor Signal (PR-87 Board)

The digital monitor signal from the DVPC-1000 is sent to the TR-40 board via this board.

3. Digital Mix Signal (PR-87 Board)

The level of the digital mix signal received from the DVPC-1000 is -20dBm. However, the rated input level of the AE-05 board is -4dBs, hence this signal is amplified by 16 dB by the ICA1 and then sent to the AE-05 board.

4-8. POWER SUPPLY SECTION

The power supply section of the DVR-1000 consists of the PS-138 board, CT-74 board and RE-32 board, and also an AC inlet, circuit breaker, and voltage selector. All of these components are contained in a single case.

The PS-138 board is the main board of the power supply section. The CT-74 board and RE-32 are installed on the primary side and secondary side, respectively, as control boards. Signals are transferred between the primary and secondary sides by means of a photocoupler.

The switching regulators are classified broadly into the following three systems, each of which is controlled by a dedicated PWM controller.

The first system is controlled by the CT-74 board. It generates input voltages of +12 V/-12 V/+5 V for the series regulators, +22 V for the control panel, -22 V for the fan motor, and also the power supply voltages for the CT-74 and RE-32 boards, respectively. This system operates as long as the power switch is ON.

The second system generates +5 V. The third system generates +14 V/+40 V for the various motors. These systems are controlled by the RE-32 board, and operate only when the conditions specified by the control sequence are satisfied.

4-8-1. Power Supply Specifications

Input voltage: (Switchable type)

100 to 120 V (90 to 132 V)
220 to 240 V (198 to 246 V)

Input frequency:

50/60 Hz (48 to 62 Hz)

Power consumption:

350 Wmax

Output voltages and current capacity:

| | |
|-----------------------|---------------------------|
| +12 V (SERIES REG.): | 3.0 A |
| -12V (SERIES REG.): | 3.0 A |
| -5 V (SERIES REG.): | 4.5 A |
| +5 V: | 20 A |
| +22 V (UNREG.): | 2.0 A (for control panel) |
| -22 V (UNREG.): | 1.0 A (for fan motor) |
| +18 V: | 1.0 A (for audio) |
| -18 V: | 1.0 A (for audio) |
| +14 V (UNREG.): | 4.0 A (for motors) |
| +40 V (UNREG.): | 3.0 A (for motors) |
| +12 V (IC104/PS-138): | 0.5 A (for MD-43 board) |
| -12 V (IC103/PS-138): | 0.5 A (for MD-43 board) |

4-8-2. Circuit Outline (PS-138/CT-74/RE-32 Boards)

This power supply consists primarily of switching regulators combined with series regulators and 3-terminal regulators for the various outputs.

The basic configurations of the switching regulators for the abovementioned three systems are identical. The AC input is rectified to become a DC voltage of about 300 V which is then input to the switching regulator. The voltage that enters the switching regulator is switched at a frequency of about 50 KHz by a half bridge method, causing rectangular waves of a frequency of about 100 KHz to be generated at the secondary side of the converter transformer. These waves are full-wave rectified at the secondary side, resulting in the specified output voltage. A fixed frequency PWM method is used for switching control.

The CT-74 board is the control board for the primary side. It consists of the PWM controller and sequence circuit of the abovementioned first system. The sequence circuit monitors the output from the auxiliary winding of the converter transformer T10, and when it judges that the output from the switching regulator has risen to an adequate level it turns ON the relay of the rush current limit circuit, thus transmitting the SUPPLY EN signal that indicates that the AC input is ON, to the secondary side. Similarly, when the AC input is turned OFF, this condition is transmitted to the secondary by the SUPPLY EN signal.

The RE-32 board is the secondary side control board. It consists of a +5 V system and motor power supply system PWM controller, a series regular control circuit, and a sequence circuit. The +5 V system switching regulator and the +12V/-12 V/-5 V series regulators operate in that sequence according to the SUPPLY EN signal received from the CT-74 board via a photocoupler. The motor power supply system operates only when the ± 12 V/ ± 5 V system power supply output and the VTR are in the normal condition.

The sequence controller outputs the POWER ON PULSE (POP) signal to the SP-01 board, and the MOTOR ACTIVE signal to the motor driver.

In the following description, the first system is taken as the PRIM system.

4-8-3. Primary Side Circuit (CT-74/PS-138 Board)

1. Input Filter

The input filter consists of a noise filter CN101 with an AC inlet mounted on the power supply case, and capacitor C30 mounted on the PS-138 board. CN101 contains a filter that rejects both normal mode and common mode noise.

2. Rush Current Limit Circuit (PS-138 Board)

This circuit limits the charging current flowing to the rectifying capacitors C5 to C10 when the power is switched ON, thus preventing an excessive current from flowing. When the power is switched ON, the rush current is limited by resistor R1 which is inserted in series with the LIVE side of the AC input, then after the lapse of a certain time relay RY1 goes ON, short circuiting R1. Relay RY1 is controlled by the sequence circuit in the CT-74 board. It is turned ON after the output of the PRIM system switching regulator has stabilized. Thermal fuse F10 that is connected in series with R1 is for preventing an abnormal temperature rise in the power supply in the event of a breakdown of the relay.

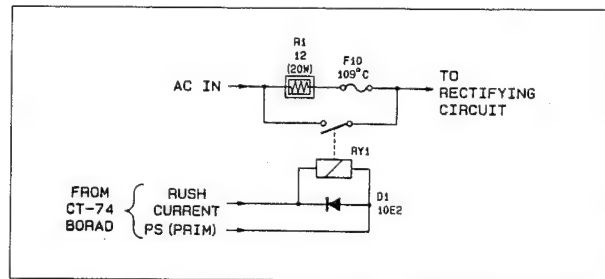

Fig. 8-3-1. Rush Current Limit Circuit (PS-138 Board)

3. Primary Side Rectifier Circuit (PS-138 Board)

The power supply voltage select switch S002 switches the primary side rectifier circuit to the voltage doubler rectifier circuit in the case of a 100V AC input, or to the full-wave rectifier circuit in the case of a 200V AC input. In both cases, a DC voltage of about 300 V is obtained after rectification. In the case of full-wave rectification, all four diodes in the diode module D2 operate. In the case of the voltage doubler rectifier circuit, diodes (1) and (2) alone operate, and reverse bias is applied to (3) and (4) so that they are continuously OFF. Capacitors C1 to C4 are for absorbing noise during the diode reverse recovery period. Varistor VDR1 absorbs external high voltage surges in order to protect the power supply circuit. At the commencement of operation, the voltage is 417 to 509 V. R4 and R5 are for providing a discharge route for C5 to C10 in the event that the switching regulator stops for some reason or other.

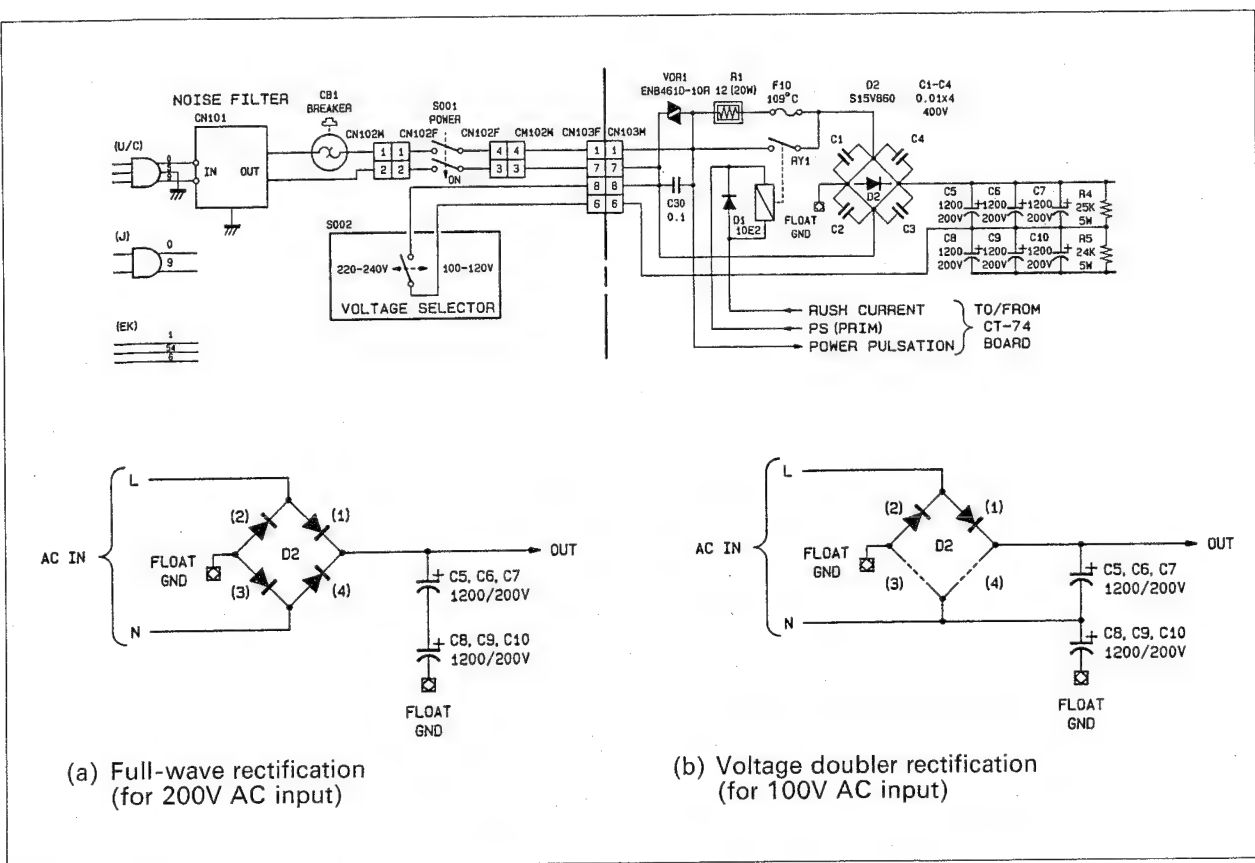

Fig. 8-3-2. Primary Side Rectifier Circuit (PS-138 Board)

4. Starting Circuit (PS-138 Board)

This circuit operates only for a fixed period after the power is switched ON, and supplies power to the power supply control circuit. After the switching regulator starts and the voltage rises to the normal output, the control circuit power is supplied from the auxiliary winding of the converter transformer.

An explanation of the starting circuit is given below based on Fig. 8-3-3. When the power switch is turned ON, charging current flows into C21 via Q7 from the rectifier circuit. At this time, the emitter voltage of Q7 is held at about 15 V by D6, causing the source voltage of Q8 to be maintained at about 15.6 V. This voltage is supplied to the CT-74 board via D4, and the CT-74 board starts the PRIM system switching regulator. At the same time, the output from the auxiliary winding of the converter transformer is supplied to the CT-74 board via D3. In other words, the higher of the voltages output from the starting circuit and the auxiliary winding is supplied to the CT-74 board. After a fixed period of time from when the power is switched ON, C21 becomes fully charged, the starting circuit stops operating, and the power for the CT-74 board is supplied from the auxiliary winding.

This starting circuit is designed so that if the switching regulator stops for some reason or other, the power must be switched OFF and then ON again. This is because C21 remains charged at the rectifier circuit output voltage, holding Q8 in an OFF status. To restart the system, therefore, C21 must be discharged by switching the power OFF. This case is different to a normal power OFF operation in that the rectified output is discharged through R4 and R5. Consequently, it takes about one to two minutes for the system to recover to a condition in which it can be restarted.

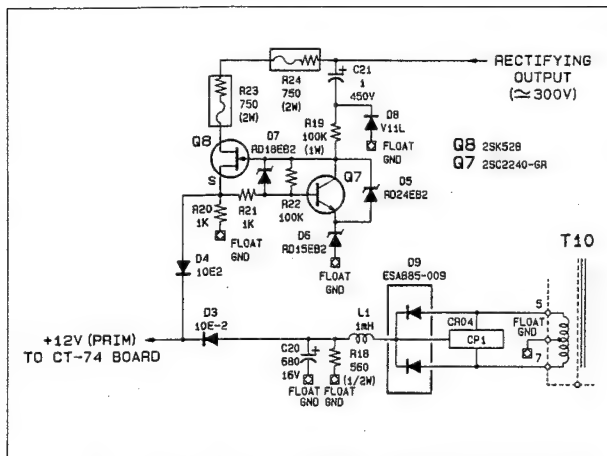

Fig. 8-3-3. Starting Circuit (PS-138 Board)

5. Temperature Rise Protection Circuit (PS-138 Board)

The output from the previously mentioned circuit output and the output from the auxiliary winding of the converter transformer pass through thermal reed switch S1 before being supplied to the CT-74 board. Normally, S1 is shorted, however if the temperature in the power supply section exceeds about 80°C, S1 goes open, cutting off the supply of power to the CT-74 board. In this case, the power must be switched OFF and then ON again, as described in sub-section 4.

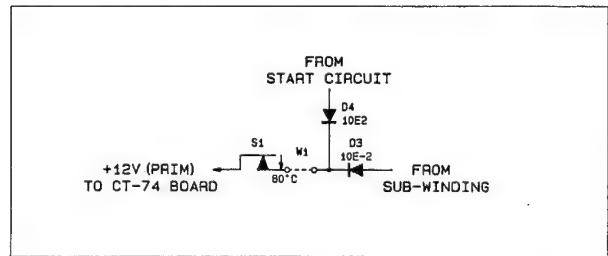

Fig. 8-3-4. Temperature Rise Protection Circuit (PS-138 Board)

6. PRIM System Power Supply Control Loop (CT-74 Board)

The voltage control circuit of the PRIM system switching regulator operates so as to maintain the output PS (PRIM) constant. This control is done by the PWM controller IC7 on the CT-74 board.

The PS (PRIM) signal that is input to the CT-74 board is voltage-divided by R18 and R19, then input to pin 1 of IC7. At the same time, the voltage set by RV2 is input to pin 2 of IC7. IC7 compares these two voltages using its own error amplifier, and operates so that they become equal.

Each switching regulator of this power supply section controls the output voltage by controlling the duty (ON/OFF times) of the switching transistor. If the input voltage drops, the switching regulator will increase the ON time, thus maintaining the output voltage constant.

In the case of a half-bridge type switching regulator, two switching signals are necessary because the switching regulator are generated by a push-pull operation. These switching signals are the outputs from pins 8 and 11 of IC7, which are sent to the respective drive transformers. The total of the ON

and OFF times of the switching signals output from IC7 are constant. In other words, these signals are fixed frequency pulse-width modulated signals. The frequency is determined by C15 and R23.

$$f = 1/2 \times 1/C15 \cdot R23 \approx 70 \text{ kHz}$$

Pin 4 of IC7 is the dead time control terminal. Together with C12 and R22, it constitutes a soft start circuit. When the power is switched ON, C12 is charged by the reference voltage of +5 V \pm 5% output from pin 14, at a time constant determined by C12 and R22, and the +5 V voltage from pin 4 gradually falls. Along with this, the duty of the output from pins 8 and 11 of IC7 rises gradually from 0, and the operation of the control circuit changes over to the previously mentioned voltage control loop operation. This soft start function prevents rush current from flowing when the power is switched ON. Also, after the system operation has stabilized, voltage is applied to pin 4 of IC7 by R22 and R25 to limit the maximum value of the duty of the switching signal, thereby preventing the duty from rising abnormally in the event of a malfunction.

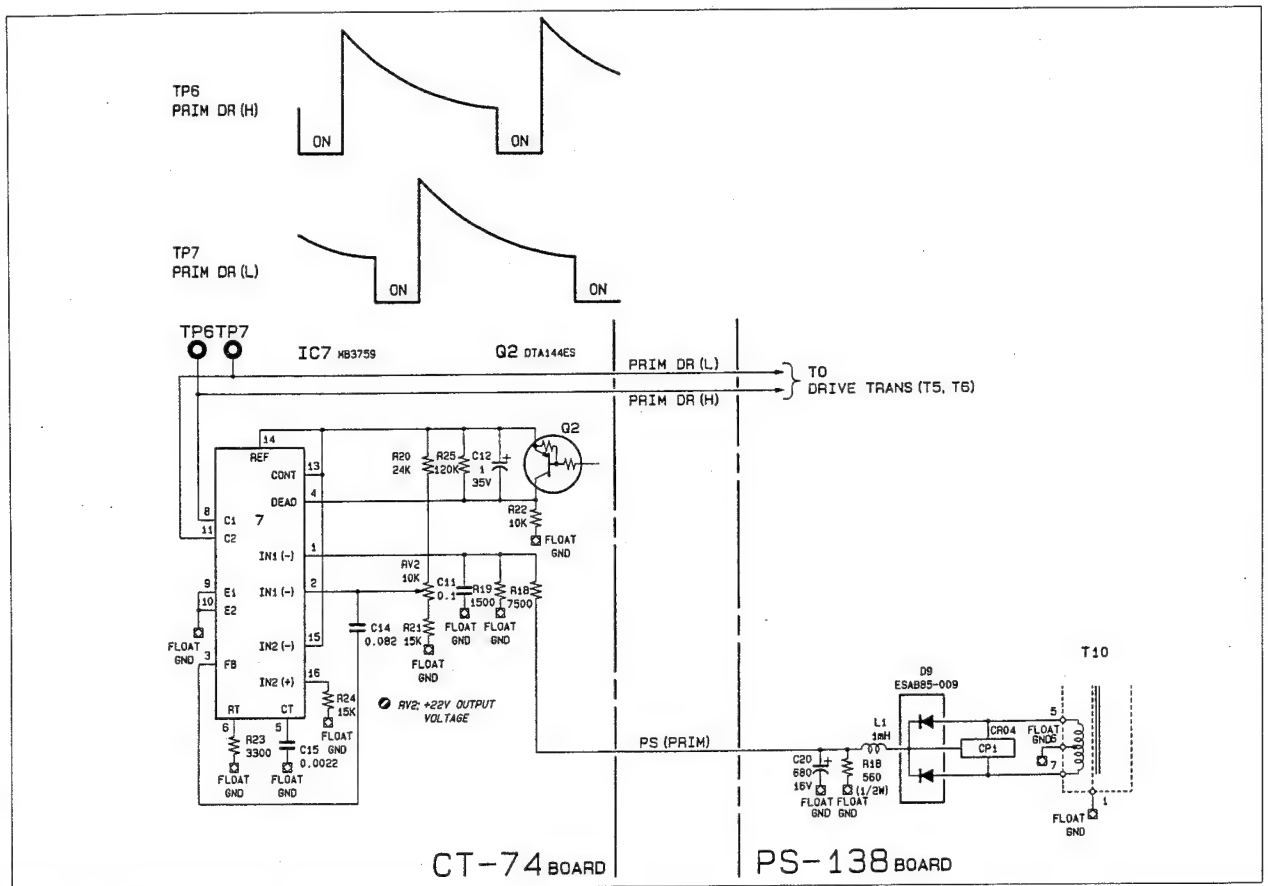

Fig. 8-3-5. PRIM System Voltage Control Loop (CT-74 Board)

7. Primary Side Sequence Circuit (CT-74 Board)

When the power is switched ON, the power supply section passes through a sequence consisting of several stages until its operation stabilizes. Initially, it is controlled by the CT-74 board. This circuit operates in the following sequence.

- (1) It senses that the specified AC voltage has been input.
- (2) It senses that the PS (PRIM) output from the PS-138 has risen sufficiently.
- (3) It turns the rush current limit circuit relay RY1 ON.
- (4) It makes the SUPPLY EN signal "NORMAL".

Fig. 8-3-6. shows the sequence circuit, and Fig. 8-3-7. shows the timing chart.

In Fig. 8-3-6., the part of the circuit between AC IN (LIVE) and TP1 is a power ON/OFF detection circuit which performs the operation of (1). The POWER PULSATION signal created from the waveform on the AC LIVE side is input to the inverter IC4. Here, the POWER PULSATION signal is shaped into a rectangular wave, and pulses of the same frequency as the AC input are obtained from pin 6 of IC4. While the output of pin 6 of IC4 is "H", the potential of pin 1 of IC4 rises at a time constant determined by R3 and C2. However, when the power is ON, the output from pin 6 of IC4 becomes "L" at the same frequency as that of the AC input, hence the voltage at pin 1 of IC4 does not reach the threshold voltage (approx. 8 V), and TP1 remains at an "H" status. When the power goes OFF, the potential at pin 1 of IC4 exceeds the threshold voltage after about three pulse cycles, hence TP1 becomes "L", and the power OFF condition is detected.

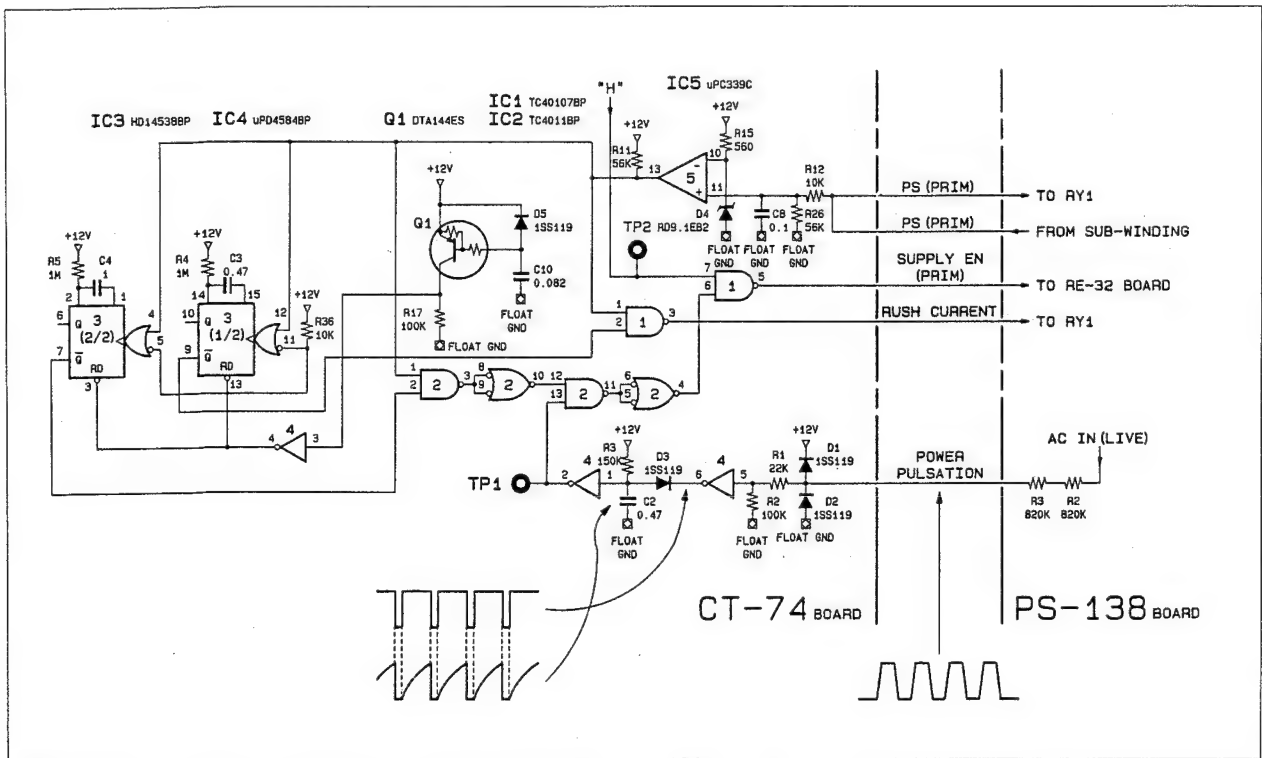

Fig. 8-3-6. Sequence Circuit (CT-74 Board)

IC5 performs the operation of (2). PS (PRIM) is input from the auxiliary winding of the converter transformer on the PS-138 board. Here, PS (PRIM) is compared with the zener voltage of diode D4 to determine whether or not PS (PRIM) has risen to about 9.1 V or more. If PS (PRIM) has risen to this value, the output from pin 13 of IC5 will be "H".

After a fixed period of time from when the rise of PS (PRIM) is detected, the operation of (3) commences. When the rise of PS (PRIM) is detected and the output from pin 13 of IC5 becomes "H", the potential of pin 12 of IC3 (1/2) also becomes "H", then after a delay of about 0.5 seconds the output from pin 9 of IC3 (1/2) becomes "H". As a result, the output from pin 3 of IC1 (RUSH CURRENT) becomes "L", causing relay RY1/PS-138 to be turned ON.

IC1 is an open drain NAND gate which has a capable of driving with 100 mA.

After a further delay of 0.5 seconds, the operation of (4) commences. In actual fact, like the start of the operation of (3), the output from pin 13 of IC5 constitutes the start timing pulses.

When the output from pin 13 of IC5 becomes "H", pin 4 of IC3 is also set to "H", then after a further delay of one second the output from pin 7 of IC3 becomes "H". When AC power is being supplied, the abovementioned power ON/OFF detection circuit output (pin 2 of IC4) is "H", hence the SUPPLY EN (PRIM) output from pin 5 of IC1 is NORMAL ("L"). The SUPPLY EN signal indicates whether or not the power supply is operating normally. If the AC supply is ON and PS (PRIM) has stabilized, NORMAL ("L") will be output. When the power goes OFF, ABNORMAL ("H") will be output.

Transistor Q1 is a reset pulse generator which is used to clear the monostable multivibrator IC3 when the power is turned ON.

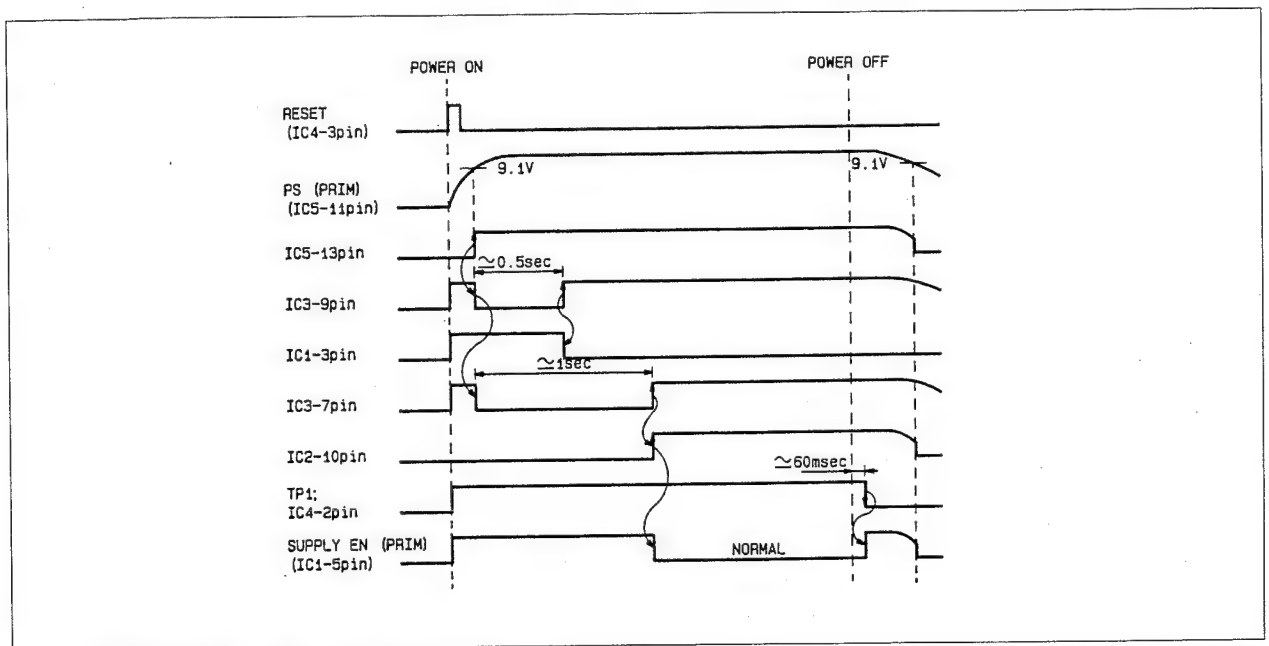

Fig. 8-3-7. Sequence Circuit Timing Chart (CT-74 Board)

8. Switching Regulator (PS-138 Board)

Fig. 8-3-8. shows the circuit of the switching regulator in the PRIM system. The switching regulator for this power supply uses a half bridge method.

The PRIM system switching regulator applies the input voltage from a single switching circuit in parallel to the two transformers T9 and T10. The basic operation is the same as the case where there is only one transformer. Q5 and Q6 are switching transistors which are turned ON and OFF alternately by switching signals from the CT-74 board. T5 and T6 are drive transformers. IC5 and IC6 are ICs used for driving the power MOS FETs (Q5 and Q6). They contain a push-pull amplifier.

A voltage of about one half of the rectified output is applied to pin 4 of transformer T10. Also, the level of pin 2 is changed alternately between the rectified output and the FLOAT GND

by the switching circuit. As a result, the rectangular waves shown in Fig. 8-3-8. are applied between pin 2 and pin 4 of T10. The peak voltage is about one half of the rectified output. The same operation takes place in transformer T9.

When the switch is turned OFF, a counter EMF is generated by the inductance of the transformer, hence a high voltage pulse is generated at the source of Q5. R15 and C19 comprise a surge absorber which is used to absorb the energy of these pulses, thereby reducing switching noise.

This completes the description of the PRIM system switching circuit. The basic operation of the other two systems, namely the +5 V system and the motor power supply system, is the same. The only difference is that in these two systems the switching signal is supplied from the RE-32 board on the secondary side. In this case, drive transformers T1 to T4 separate the secondary and primary sides from each other.

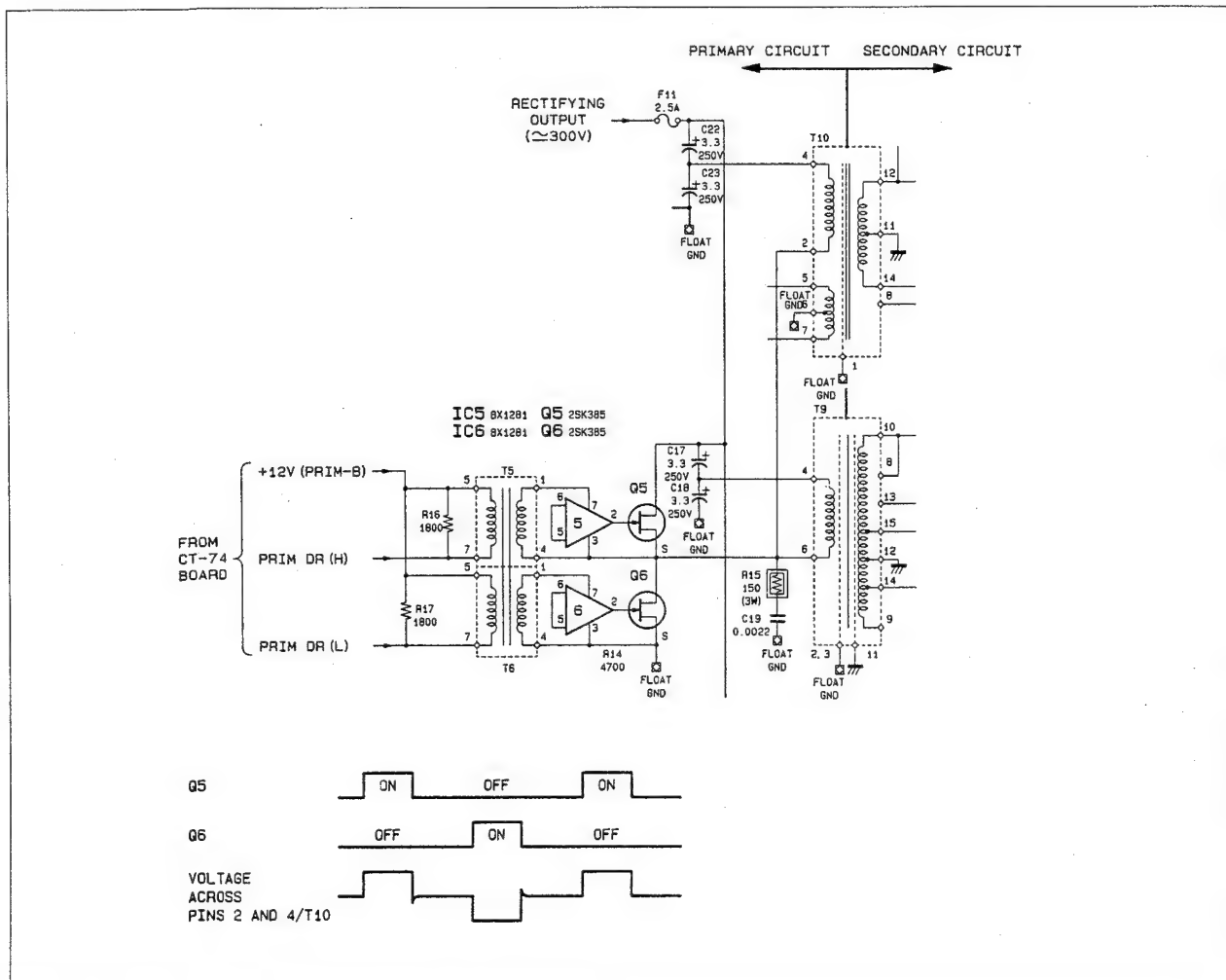

Fig. 8-3-8. PRIM System Switching Circuit (PS-138 Board)

4-8-4. Secondary Circuit (RE-32/PS-138 Board)

1. Secondary Rectifier Circuit (PS-138 Board)

Fig. 8-4-1. shows the secondary side rectifier circuit of the PRIM system. The same rectangular waves as the voltage applied to the primary winding are generated at the secondary side of converter transformers T9 and 10. This rectangular wave output is full-wave rectified by diodes D106 to 112 which are connected to each tap of the secondary side winding. It then passes through a smoothing circuit consisting of a choke coil and capacitors, and is output as a DC voltage.

The diodes used are twin type Schottky diodes or high speed rectifying diodes.

The input voltage (+12 V/-12 V/-5 V) to the series regulator, the +22 V power supply for the control panel, and the -22 V

power supply for the fan motor are generated in the PRIM system.

CP106 to CP112 are the CR modules which are connected in parallel to each diode. They are used to absorb noise generated during the reverse recovery period of the diodes.

This completes the description of the PRIM system. The circuit configuration for the other two systems is the same.

2. Series Regulator (PS-138 Board)

Each of the +12 V, -12 V and -5 V outputs from the PRIM system switching regulator is regulated by the series regulator and then output. Fig. 8-4-1. shows the regulator circuit.

Q102 to Q106 are control transistors, and R123 to R125, R127 and R129 are current detection resistors. R123 to R125 maintain a balance between the current flowing through the three -5 V control transistors.

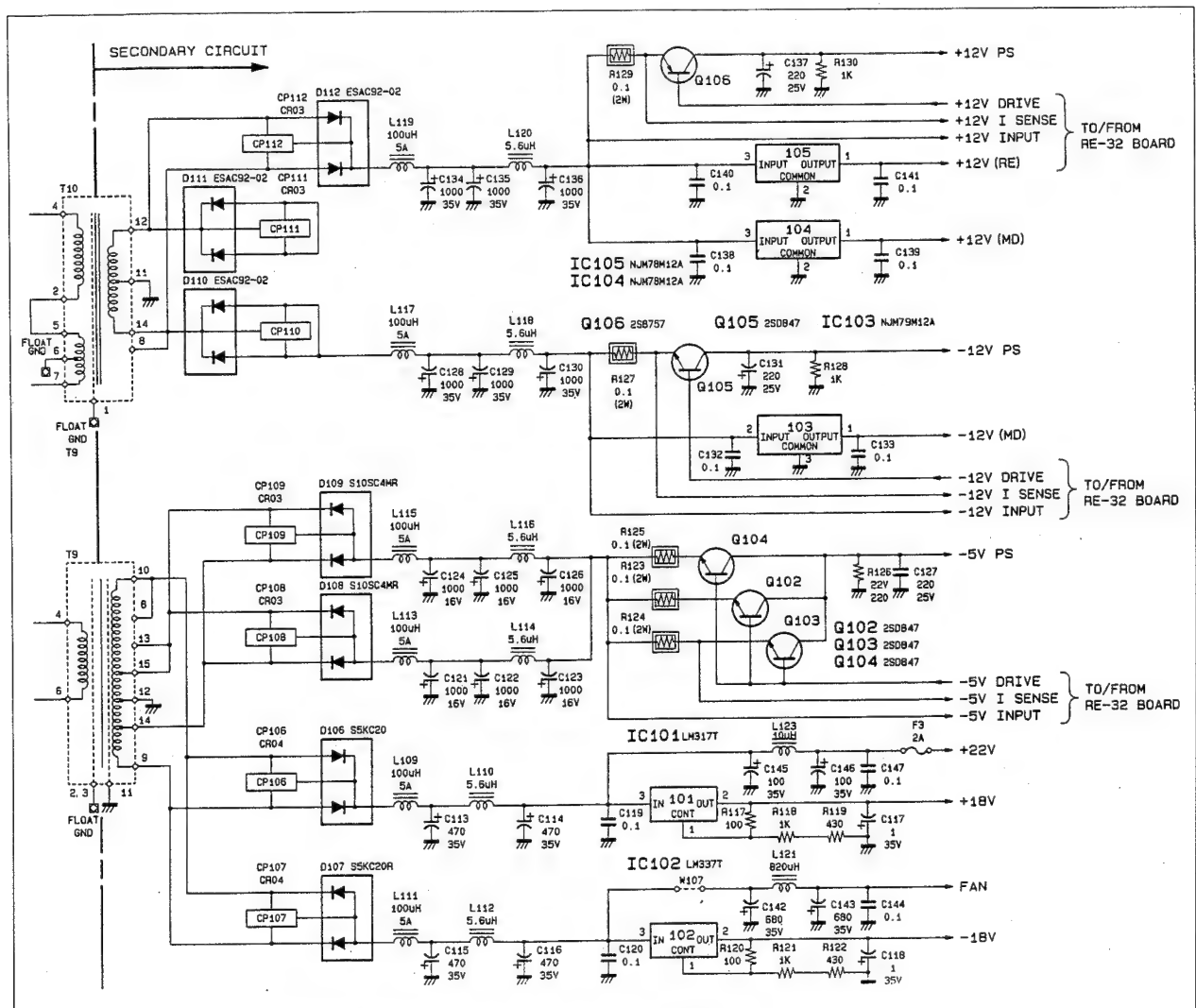

Fig. 8-4-1. Secondary Side Rectifier Circuit and Series Regulator (PS-138 Board)

3. Series Regulator Control Circuit (PS-138 Board)

Each of the +12 V, -12 V and -5 V series regulators is controlled by the RE-32 board. The control circuit consists of a constant voltage control loop and an overload protection loop. The constant voltage loop compares the output voltage with the reference voltage and operates to maintain the output voltage constant. Normally, the constant voltage control loop operates, however if the load becomes high, the overload control loop will operate instead. Fig. 8-4-2. shows the V-I characteristics of these loops.

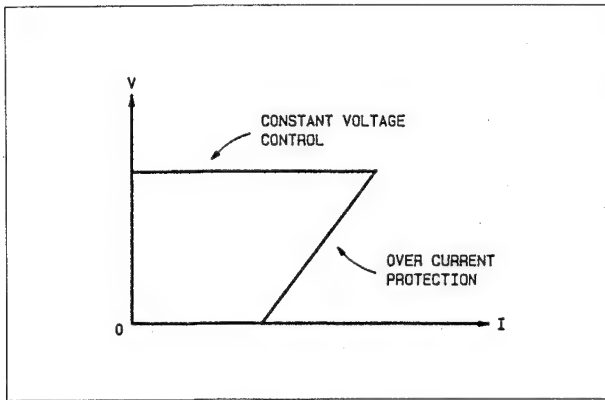

Fig. 8-4-2. V-I Characteristics (RE-32 Board)

(A) Reference voltage generator (RE-32 board)

When the series regulator operates in accordance with the sequence, TP1 becomes "L", and current flows into photocoupler IC4. As a result, current flows through zener diodes D10 and D11, generating the + side (D10) and - side (D11) reference voltages. When TP1 becomes "H" level and the reference voltage becomes 0 V, the series regulator stops. The zener voltage of each diode is between 5.9 and 6.5 V, and its temperature coefficient is $\pm 0.005\%/^{\circ}\text{C}$. Q6 and Q7 constitute a constant current power supply. It is designed so that the zener voltage is unaffected when the input voltage fluctuates. C15 and C16 raise the reference voltage gradually when the power is switched ON, and also stabilizes the reference voltage.

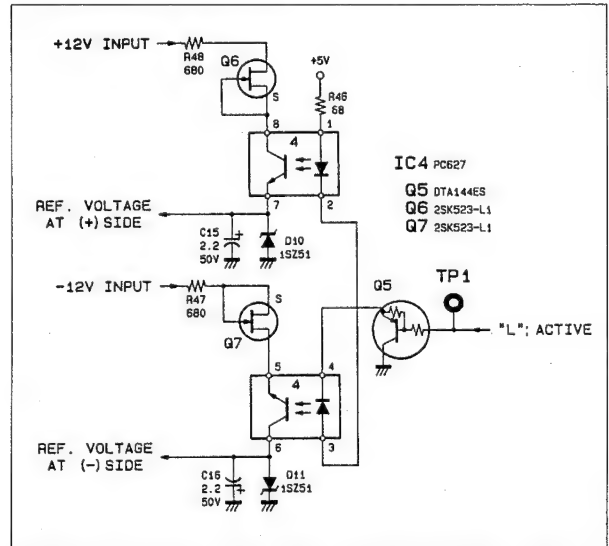

Fig. 8-4-3. Reference Voltage Generator (RE-32 Board)

(B) Series regulator control loop (RE-32 board)

Fig. 8-4-4. shows the regulator control loop for the +12 V system series regulator. The constant voltage control circuit is near the op amp IC2 at the right side of the figure, and the overload protection circuit is at left side. These circuits are connected to each other by D1 and D2, so that one of them drives the drive transistor Q1. Normally, D1 is ON, and the voltage of the +12 V SENSE signal connected to the mother board MB-133 is compared with the reference voltage and regulated so that there becomes equal. RV1 is the output voltage adjustment potentiometer.

When the load increases, the potential difference across R129 on the PS-138 board increases. As a result, the potential of pin 6 of IC2 rises, and the potential of pin 7 of IC2 falls. When the load increases above a certain point, D2 goes ON and D1 goes OFF, and control is transferred to the overload protection loop. RV2 is a potentiometer which is used to adjust the value of current at which control is transferred to the overload protection loop.

D3 is a voltage shift diode used to drive Q1. R4 is used to prevent an abnormal voltage from being output when the +12 V SENSE signal goes open.

This completes the description of the +12 V system. The basic operation of the control loops for the -12 V and -5 V systems is the same. The only differences are that the power for the op amp is taken from the -12 V system and the output voltage is compared with the - (minus) side reference voltage.

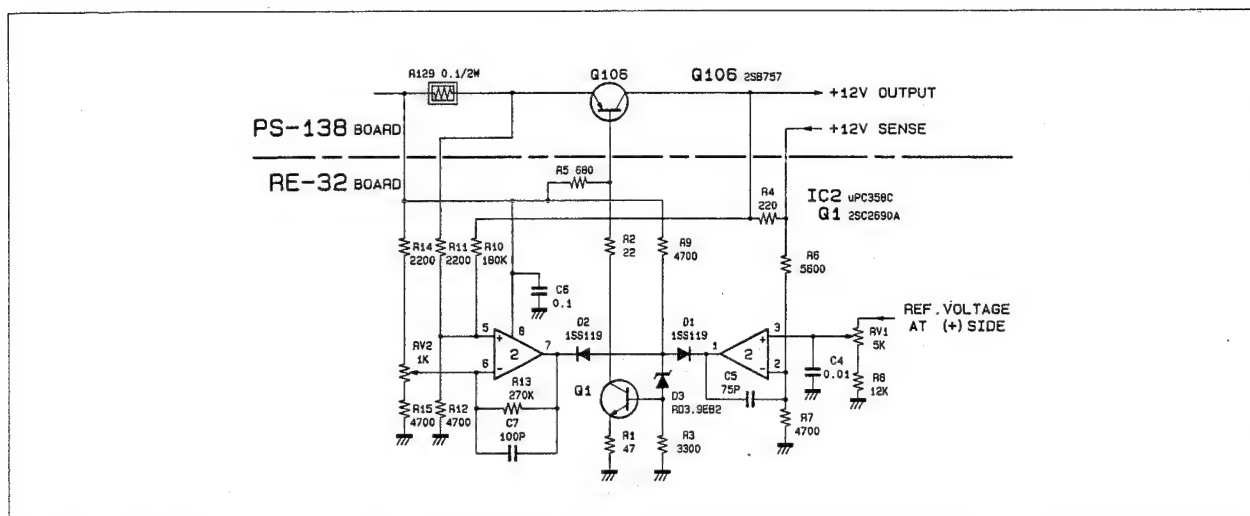

Fig. 8-4-4. +12 V Series Regulator Control Circuit (RE-32 Board)

4. +5 V System Control Loop (RE-32/PS-138 Board)

Fig. 8-4-5. shows the +5 V system control loop. The PWM controller IC6 in the RE-32 board controls the duty of the switching ON/OFF signal, thus controlling the output voltage. As mentioned above, the PWM controller IC6 contains two error amplifiers. The +5 V SENSE signal is applied to one of these (pins 1 and 2), and is regulated so that it becomes equal to the set voltage. The other error amplifier (pins 15 and 16) constitutes the overload protection loop. These error amplifiers are connected to each other inside IC6. Control is transferred preferentially to the error amplifier which operates so as to reduce the output. Consequently, if the load increases, control is performed preferentially by the overload protection loop, the V-I characteristics of which are similar to those shown in Fig. 8-4-2..

Overload detection is performed using the series-connected resistors L106 and 107 (20 mΩ or less) on the PS-138 board. This is because the current drawn from the +5 V system is larger than that drawn from the other systems, resulting in a large voltage drop. RV7 and RV8 are potentiometers which are used to adjust the output voltage and the limit value of the current, respectively.

R107, D116, C106 and R108 constitute a ripple detection rectifier circuit. When the AC component of the ripple is applied, with the waveform reversed, to pin 2 of the IC6/RE-32 board, the ripple components that cannot be completely eliminated using a normal voltage control loop are canceled out. In addition, by adjusting RV8 for minimum ripple, the ripple can be reduced to the order of several mVp-p. The +5V ON/OFF signal is sent from the sequence circuit to TP2 of the RE-32 board. When TP2 is "H" level, Q8 goes OFF and C30 is charged at a time constant determined by C30 and R70. As a result, the potential of pin 4 of IC6 falls, the duty of the switching signal starts to increase gradually (soft start), and the constant voltage control loop starts. Conversely, when TP2 becomes "L" level, the potential of pin 4 of IC6 rises to the reference value of +5 V of pin 14, hence the switching regulator stops.

R70 and R71 limit the maximum value of the duty of the switching pulse regulator. R66 is a resistor which is used to prevent a malfunction if the +5 V SENSE line goes open. R166 on the PS-138 board is a dummy resistor which draws a very small current even under no-load conditions in order to stabilize operation of this circuit.

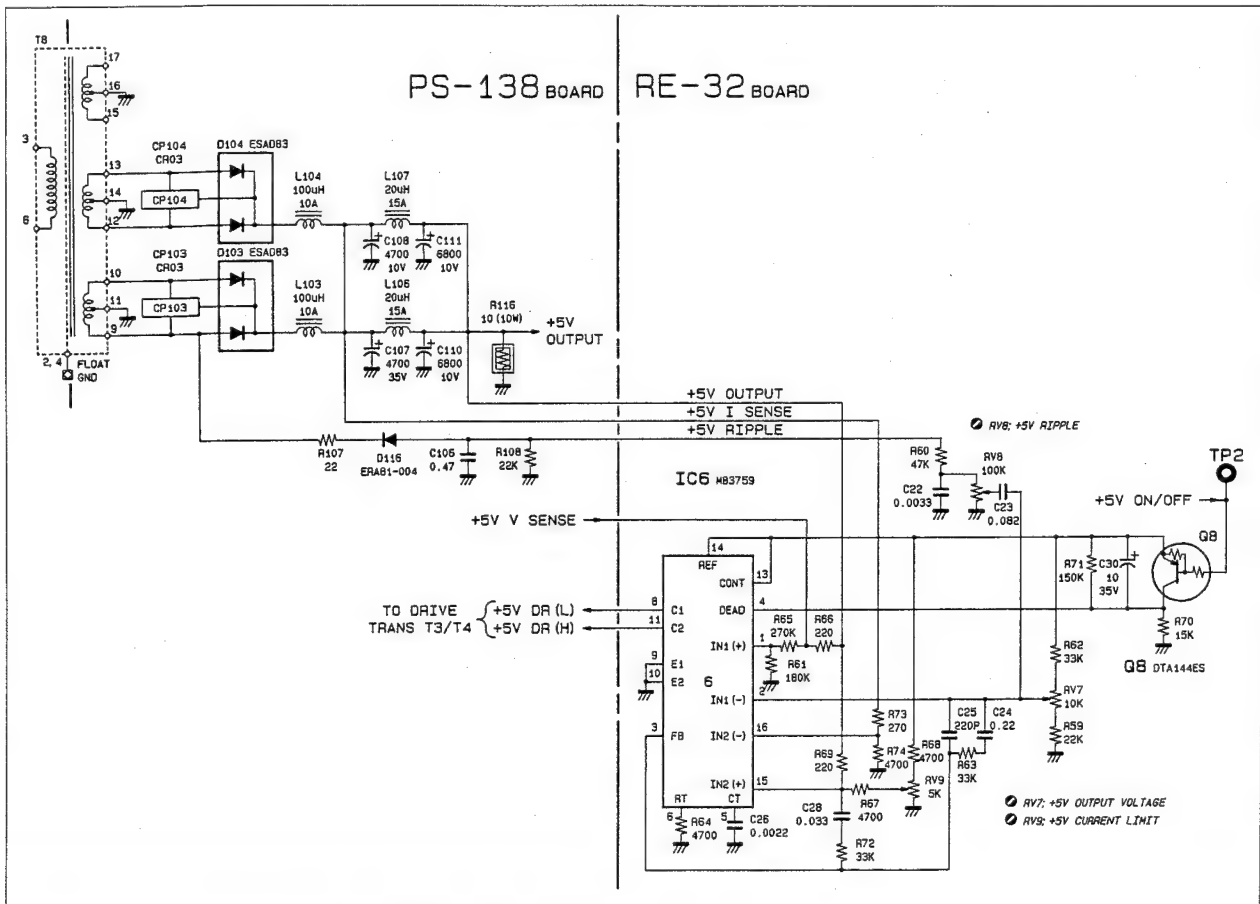

Fig. 8-4-5. +5 V System Control Loop (RE-32/PS-138 Board)

5. Motor Power Supply System Control Loop (RE-32/PS-138 Board)

Power supply voltages of +14 V and +40 V are output for driving the motors.

IC11 on the RE-32 board is a PWM controller. This system has rectifier circuit for a voltage feedback consisting of D133, R105, R106 and C101. The feedback voltage is controlled so that it is equal to the set voltage. Consequently, neither the +14 V nor the +40 V power supply voltages is actually regulated, but rather they vary depending on the magnitude of the load. For example, the output voltage of the +14 V system can vary between +13.5 V (4 A load) and +15V (no load). However, this fluctuation is absorbed by the motor drive circuit MD-43 board, so it poses no problem in practice. A voltage feedback method was adopted because if one of the +14 V or +40 V power supply voltages were to be sensed, and the load on the sensed output was light and that on the other output was heavy, the output voltage of the power supply that was not sensed would be extremely low. It was also adopted because a dummy resistor with a very high value would have to be placed across the output that was not sensed in order to

prevent the voltage from dropping markedly.

The circuit in the vicinity of Q101 which has been added to the +40 V output of the PS-138 board is a power zener circuit which prevents the +40 V output from rising to more than +42 V under no-load conditions. This circuit uses D114 and D115 which sense an increase of the +40 V output to +42V or higher, and turn Q101 ON, thus passing current through R114 and R115. Consequently, a dummy load is inserted only when the load is light, thus minimizing electric power loss.

A control signal is sent from the sequence circuit to TP7 on the RE-32 board. Like the +5 V system, when the control signal is "H" level, this system starts, and when the control signal is "L" level, the system stops.

F1 and F2 on the PS-138 board are fuses used for overload protection. They each have a rating of 5 A.

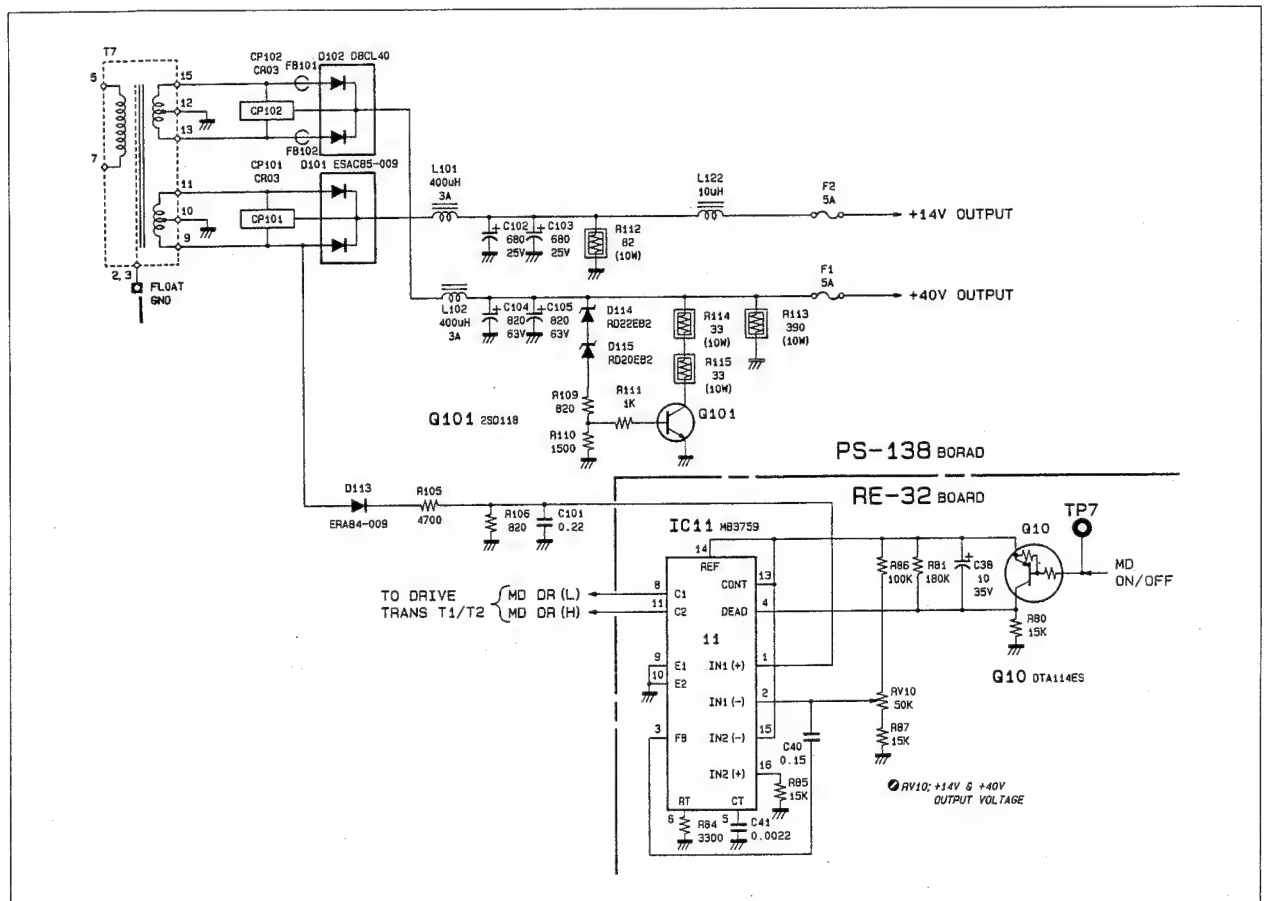

Fig. 8-4-6. Motor Power Supply System Control Loop (RE-32/PS-138 Board)

6. Secondary Side Sequence Circuit (RE-32 Board)

Fig. 8-4-7. shows the secondary side sequence circuit. This circuit has the following functions.

- (1) It switches the +5 V system output ON and OFF.
- (2) It switches the series regulator output ON and OFF.
- (3) It checks whether or not the ± 5 V and ± 12 V outputs are normal.
- (4) It checks whether or not the system is operating normally.
- (5) It turns the +14 V and +40 V outputs for the motor ON and OFF.
- (6) It generates a POP (Power on Pulse) signal.

Function (1):

When the SUPPLY EN signal output from the CT-74 board is "NORMAL" ("LOW" level), this signal passes through the photocoupler on the PS-138 board to the RE-32 board. This signal is inverted by IC7 and used to drive Q8. As a result, the +5 V system switching regulator starts.

Function (2):

The +5 V system switching regulator starts, and when comparator IC5 has confirmed that the +5 V system output has risen above +3.9 V, "H" is input to pin 5 of IC8. Because the output from pin 2 of IC7 is "H" level, the output from pin 2 of IC7 also becomes "H" level. The output from pin 2 of IC7 is delayed by R101 and C101, then inverted once again by IC7 in the next stage. As a result, TP1 becomes "L" level, Q5 is driven, and the series regulator starts.

Function (3):

IC5 checks the +12 V, -12 V and -5 V outputs in addition to the +5 V output. TP5 is set to "L" level only if all outputs are normal.

Function (4):

TP6 checks whether or not the system is operating normally. If the following two conditions are satisfied, the system is operating normally. In this case, TP6 will be "H" level.

- The SYSTEM HOLD signal received from the SP-01 board must be "NORMAL" ("L" level).
- The OVERHEAT signal received from the MD-43 board must be "NORMAL" ("L" level).

Function (5):

The POP pulse indicates that the operation of the power supply has stabilized. It is sent to the SP-01 board and used as an initializing pulse for the system. Also, IC8 confirms that TP6 is "H" level, that is, the system is normal. If both of these conditions are satisfied, TP7 is set to "H" level, and the output from the +14 V and +40 V power supplies starts. At the same time, the MOTOR ACTIVE signal is set to "H" level and the MOTOR STOP signal to "L" level.

The above sequence is shown in Fig. 8-4-8..

Function (6):

The monostable multivibrator IC10 delays the timing at which the SUPPLY EN signal becomes "NORMAL" by about 2 seconds. If TP5 is "H" subsequent to this timing, that is if ± 12 V and ± 5 V are output normally, the output from pin 12 of IC7 will become "L" level, and the POP signal ("L" level) from Q9 will be output.

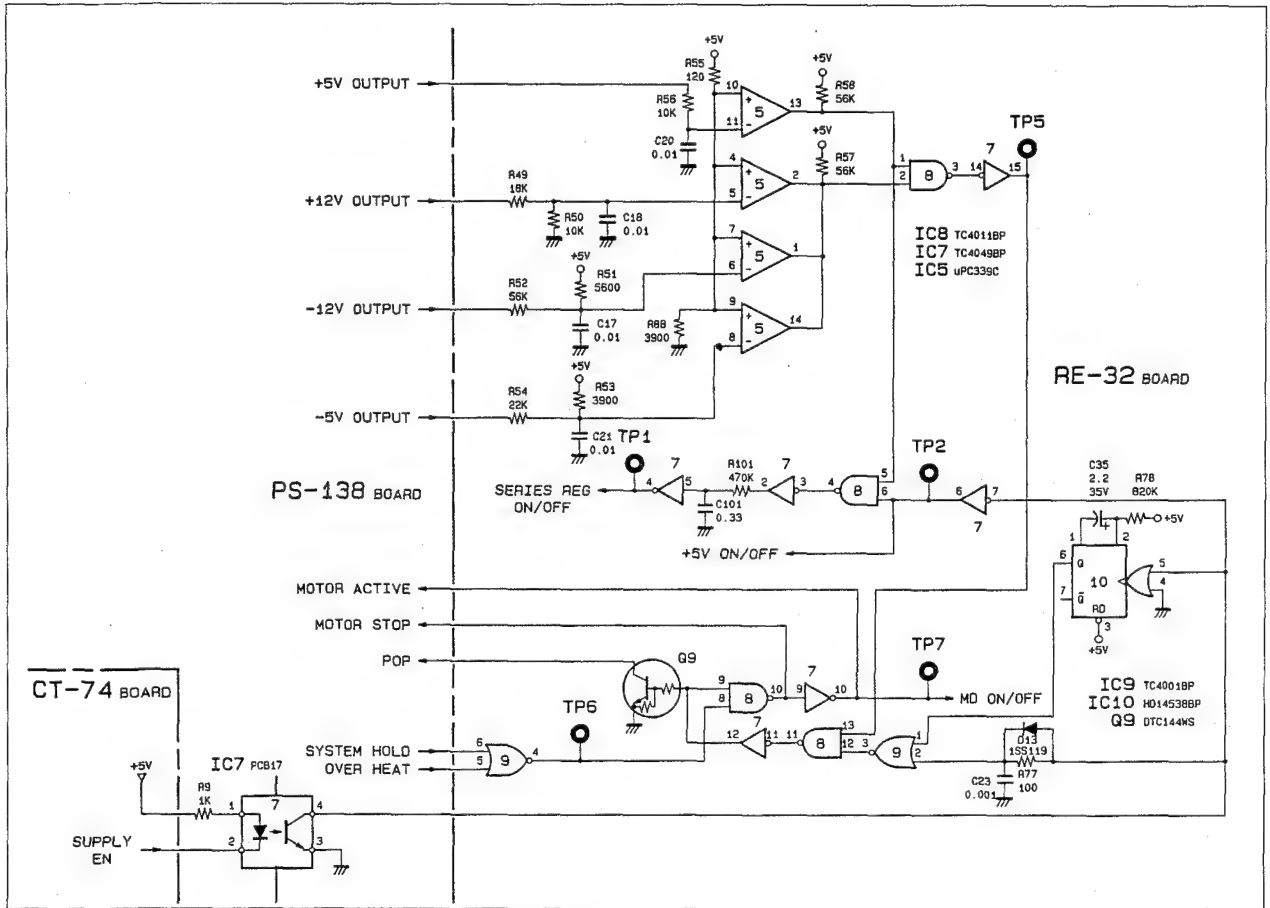

Fig. 8-4-7. Secondary Side Sequence Circuit (RE-32 Board)

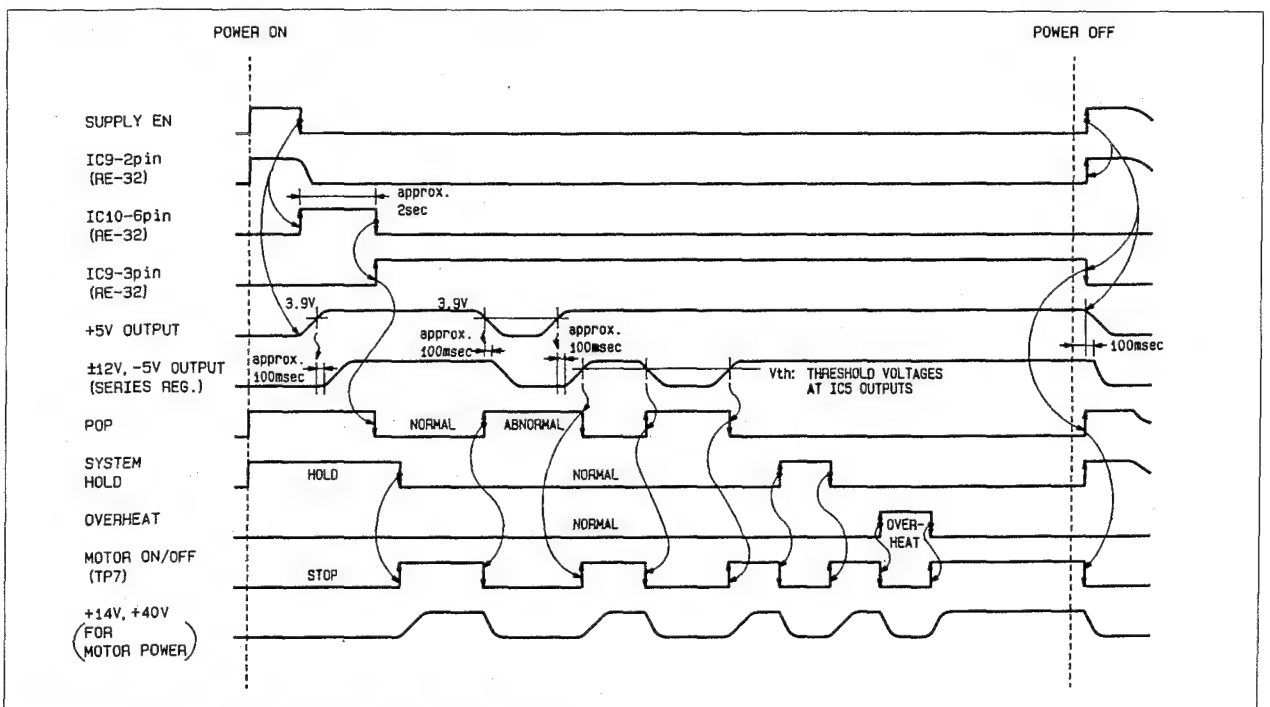

Fig. 8-4-8. Sequence Circuit Timing Chart (RE-32 Board)

7. Drive Voltage Stop Circuit (RE-32 Board)

This circuit shuts off the supply of power to drive transformers T1 to T4 in the event that the voltage of the +12 V power supply on the RE-32 board drops for some reason or other, disabling all outputs other those from the PRIM system.

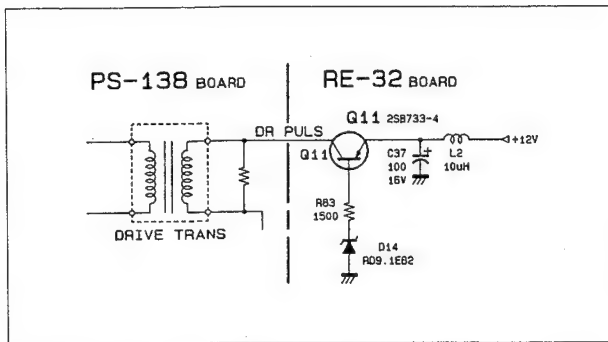

Fig. 8-4-9. Drive Voltage Stop Circuit (RE-32 Board)

8. 3-terminal Regulator (PS-138 board)

In addition to the switching regulators and series regulators described so far, 3-terminal regulators are used for small capacity power supplies.

- (1) IC105: +12 V for RE-32 board
- (2) IC104: +12 V for MD-43 board
- (3) IC103: -12 V for MD-43 board
- (4) IC101: +18 V for audio
- (5) IC102: -18 V for audio
- (6) IC1: +5 V for RE-32 board

(1) and (2) are connected to the input side of the +12 V series regulator, and (3) is connected to the input side of the -12 V series regulator.

(4) and (5) use 3-terminal regulators provided with a CONT terminal, and are supplied with +22 V and -22 V, as shown in Fig. 8-4-10.. The output voltage can be varied by changing R117 to R119 and R120 to R122 which are connected to the respective CONT terminals.

(6) is on the RE-32 board. It generates +5 V from +12 V. It is used mainly as a power supply for the logic ICs.

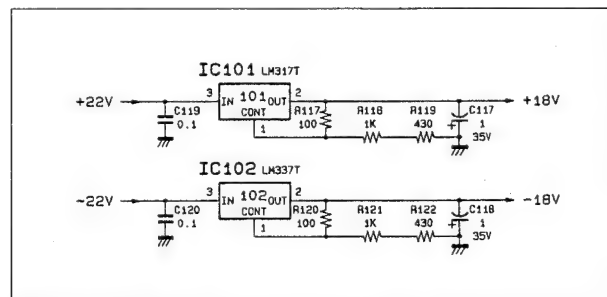

Fig. 8-4-10. ±18 V 3-terminal Regulator (PS-138 Board)

SECTION 5

PERIODICAL INSPECTION AND MAINTENANCE

It is recommended that the inspection and maintenance described below be performed periodically and whenever necessary so that the unit can perform its functions efficiently and so that its life can be extended.

5-1. PERIODICAL INSPECTION

The appropriate timing for cleaning, checking, and replacing the main parts are shown in the table. Although the timing for replacing parts depends on the conditions of usage of the unit, use the table as a guide for making a maintenance and inspection plan. The hours shown in the table are those recorded by the built-in timer of the DVR-1000. The timing of the periodical inspection of the DVPC-1000 is also shown in the table.

- . The timer is displayed on the control panel. Refer to Section 3-13-3 of the Operation Manual concerning the method for displaying it.
- . The timer of the DVR-1000 shows the total operating times and frequencies of the following four kinds of operations.

OPERATION (OP): Machine-on time of DVR-1000

DRUM RUN (D.R): Rotating time of the scanner

TAPE TRAVEL (T.T): Transport time of the tape

Time in terms of the tape length

THREADING (TRE): Frequency of loading and unloading a cassette is counted as one time

- . If the corresponding part is not clear, refer to the appropriate page of the Maintenance Manual (see "Page of Sec. D" column in the table).

OP: OPERATION D•R: DRUM RUN T•T: TAPE TRAVEL TRE: THREADING

5. PERIODICAL INSPECTION AND MAINTENANCE

| Item | Part No. | Page of Sec. D | Reference Timer | Periodical Inspection Timing | | | Remarks |
|--|-------------|--------------------------|-----------------|------------------------------|--------|--------------------------|---|
| | | | | Cleaning | Check | Replacement | |
| Tape transport Sec. Drum block Tape guide Stationary head | | | | 1Month | | | • Clean according to Sec. 5-2-1. |
| Tracking check | | | | | 1Month | | • Check according to Sec. 5-2-2. |
| Scanner Ass'y | A-6050-471- | D32,33,34 | D•R | | 500H | | • Check according to Sec. 5-2-3 (Head projecting: 25 μ or more). • Replace, when necessary, according to Sec. 6-1. |
| Drum Ass'y (DDH-01A) | A-6050-457- | D-32,33,34 | D•R | | | 5000H | • Replace according to Sec. 6-2. |
| Roller guide (N) Ass'y (S5•T5•T6) | X-3715-375- | D-23,24,25 D-26,27,28 | D•R | | 2500H | 5000H | • Clean according to Sec. 5-2-1. |
| Entrance slant guide Ass'y | A-6029-046- | D-29,30,31 | D•R TRE | 2500H | 2500H | 15000H 80000 Times | • Check according to Sec. 9-2, tape path Check, and Sec. 5-2-2, tracking Check. Apply oil and grease according to Sec. 5-2-4 when checking. • Replace according to Sec. 6-9 and 6-10. |
| Exit slant guide Ass'y | A-6029-048- | D-29,30,31 | D•R TRE | 2500H | 2500H | 15000H 80000 Times | |
| S Drawer guide Ass'y | A-6029-045- | D-23,24,25 | D•R TRE | 2500H | 2500H | 15000H 80000 Times | |
| Slant guide pin | 3-715-495- | D-29,30,31 | D•R | | | 7500H | |
| Roller guide (W) Ass'y (S3) | X-3715-376- | D-23,24,25 | D•R | | 2500H | 5000H | • Check the rotation of the roller guide. |
| Roller guide sub-Ass'y (S2) | X-3715-377- | D-29,30,31 | D•R | | 2500H | 5000H | |
| Slider guide (T2) | 3-722-964- | D-29,30,31 | D•R | | | 5000H | |
| Reel motor (DCU-6A) | 8-835-227- | D-20,21,22 | D•R | | 2500H | 7500H | • Check the S side according to Sec. 10-6 and the T side according to Sec. 10-7. • Replace according to Sec. 6-6. |
| Reel table Ass'y | A-6029-005- | D-20,21,22 | D•R | | | 7500H | • Replace according to Sec. 6-6. |
| Brake arm Ass'y | X-3715-393- | D-20,21,22 | D•R | | | 2500H | • Replace according to Sec. 6-7. |
| Plunger solenoid | 1-454-433- | D-20,21,22 | D•R | | 2500H | 7500H | • Check according to Sec. 3-4-7. • Replace according Sec. 6-7. |
| Reel shift motor (DNR-4700H) | 1-541-376- | D-20,21,22 | D•R | | 2500H | | |
| Motor frame (S) | 3-715-614- | D-20,21,22 | D•R | | 2500H | | • Check according to Sec. 3-4-6. |
| Motor frame (T) | 3-715-615- | D-20,21,22 | D•R | | 2500H | | • Replace, when necessary, according to Sec. 6-8. |
| Reel shift shaft | 3-715-316- | D-20,21,22 | D•R | | 2500H | | |
| Timing belt | 3-715-359- | D-20,21,22 | D•R | | 2500H | | |

OP: OPERATION D•R: DRUM RUN T•T: TAPE TRAVEL TRE: THREADING

| Item | Part No. | Page of Sec. D | Reference Timer | Periodical Inspection Timing | | | Remarks | |
|--------------------------------|-------------|----------------|-----------------|------------------------------|-------|--------------------------|---|---|
| | | | | Cleaning | Check | Replacement | | |
| Worm gear (L) | 3-715-354- | D-20,21,22 | D•R | | 2500H | | <ul style="list-style-type: none"> • Check according to Sec. 3-4-6. Apply oil and grease according to Sec. 5-2-4 when checking. • Replace, when necessary, according to Sec. 6-8. | |
| Worm gear (R) | 3-715-354- | D-20,21,22 | D•R | | 2500H | | | |
| Worm wheel (L) | 3-715-348- | D-20,21,22 | D•R | | 2500H | | | |
| Worm wheel (R) | 3-715-348- | D-20,21,22 | D•R | | 2500H | | | |
| Bearing | 3-715-351- | D-20,21,22 | D•R | | 2500H | | | |
| Threading motor (MNR-7400A) | 8-835-123- | D-29,30,31 | D•R TRE | | 2500H | 7500H 50000 Times | <ul style="list-style-type: none"> • Check according to Sec. 3-4-6. Apply oil and grease according to Sec. 5-2-4 when checking. • Replace, when necessary, according to Sec. 6-13. | |
| Worm gear | 3-715-490- | D-29,30,31 | D•R | | 2500H | | | |
| Worm gear (T) | 3-715-435- | D-29,30,31 | D•R | | 2500H | | | |
| Worm gear (S) | 3-715-436- | D-29,30,31 | D•R | | 2500H | | | |
| Link wheel | 3-715-422- | D-23,24,25 | D•R | | 2500H | | | |
| Link wheel (S) | 3-715-426- | D-23,24,25 | D•R | | 2500H | | | |
| Gear | 3-715-479- | D-29,30,31 | D•R | | 2500H | | | |
| SS rail | 3-715-613- | D-23,24,25 | D•R TRE | | 2500H | 7500H 50000 Times | | |
| S rail | 3-715-325- | D-29,30,31 | D•R TRE | | | 7500H 50000 Times | | |
| T rail | 3-715-326- | D-29,30,31 | D•R TRE | | 2500H | 7500H 50000 Times | | |
| S retainer block | 3-716-723- | D-32,33,34 | D•R TRE | | 2500H | 15000H 80000 Times | | |
| T retainer block | 3-716-724- | D-32,33,34 | D•R TRE | | 2500H | 15000H 80000 Times | | |
| SS retainer block | 3-716-725- | D-23,24,25 | D•R TRE | | 2500H | 15000H 80000 Times | | |
| Cassette compartment Ass'y | A-6028-008- | D-17,18,19 | D•R TRE | 500H | 2500H | 7500H 50000 Times | | <ul style="list-style-type: none"> • Clean according to Sec. 5-2-1. • Check according to Sec. 3-4-6. Apply oil and grease according to Sec. 5-2-4 when checking. |
| Tension regulator holder Ass'y | A-6029-029- | D-23,24,25 | D•R | | 2500H | 7500H | | • Check according to Sec. 9-3. |
| Tension arm Ass'y | X-3715-323- | D-23,24,25 | D•R | | | 2500H (Note1) | • Replace according to Sec. 6-11. | |

Note 1: Periodical replacement of the guide is not required if a ceramic guide is used.

5. PERIODICAL INSPECTION AND MAINTENANCE

OP: OPERATION D•R: DRUM RUN T•T: TAPE TRAVEL TRE: THREADING

| Item | Part No. | Page of Sec. D | Reference Timer | Periodical Inspection Timing | | | Remarks |
|---------------------------|-------------|----------------|-----------------|------------------------------|------------------|------------|---|
| | | | | Cleaning | Check | Replacment | |
| Full erase head | 8-825-770- | D-23,24,25 | | | | | • Replace, when necessary, according to Sec. 6-12. |
| F guide (T4) | 3-715-403- | D-26,27,28 | D•R | | 2500H (Note2) | 7500H | • When checking, rotate the tape guide and the guide flange as described in Note 2. |
| Guide fiange | 3-715-402- | D-26,27,28 | D•R | | (Note2) 2500H | 7500H | |
| Audio/CTL head | 8-825-770- | D-23,24,25 | D•R | | 2500H | 7500H | • Check the audio characteristics. • Replace according to Sec. 6-16. |
| Capstan motor (BHF-1916A) | 8-835-234- | D-26,27,28 | D•R | | 2500H | 5000H | • Check according to Sec. 10-5. • Replace according to Sec. 6-14. |
| Pinch roller Ass'y | A-6029-043- | D-23,24,25 | D•R | | | 2500H | • Clean the V groove that presses the pinch roller. |
| Plunger solenoid | 1-454-434- | D-26,27,28 | D•R | | 2500H | 5000H | |
| Plunger pin | 3-715-398- | D-26,27,28 | D•R | | 2500H | 7500H | • Check according to Sec. 3-4-6. |
| Pinch press plate | 3-715-389- | D-26,27,28 | D•R | 1Month | | 7500H | • Replace according to Sec. 6-15. |
| Lithium battery (IF-138) | 1-528-218- | | D•R | | | 5000H | • Replace according to Sec. 2-5-3. |
| DC fan motor (small) | 1-541-436- | D-5,6,7 | OP | 1Month | | 15000H | • Clean according to Sec. 5-2-1. |
| DC fan motor (large) | 1-541-437- | D-11,12,13 | OP | 1Month | | 15000H | |
| Air filter | 3-735-190- | D-11,12,13 | OP | 1Month | | 15000H | • Clean according to Sec. 5-2-1. |
| DVPC-1000 | | | | | | | |
| DC fan motor | 1-541-203- | D-11,12,13 | OP | 1Month | | 15000H | • Clean according to Sec. 5-2-1. |
| DC fan motor | 1-541-337- | D-8,9,10 | OP | 1Month | | 15000H | |

Note 2: Rotate the guide so that the worn portion of the guide does not touch the tape.

Generally, the guide should be rotated approximately 90 degrees clockwise.

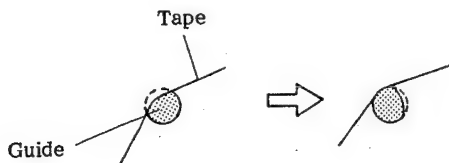

5-2. MAINTENANCE

5-2-1. Cleaning

Basic Knowledge

A. Clean the following portions.

- .Rotary head and upper drum tape running surface
- .Lower drum read surface and tape running surface
- .Tape path system
- .Stationary head
- .Slider rails
- .Air filter
- .DC fan motors
- .Cassette compartment

B. When cleaning, turn the power off.

C. Do not touch the greased portions, especially the slider section, when cleaning. If there is grease on the cleaning piece, replace it with a clean one.

(Cleaning the Rotary Head and the Upper Drum Tape Running Surface)

1. Remove the drum cover and clean the rotary head marked by  shown in Figure 5-1, with a cleaning piece soaked with alcohol by pressing it lightly against the head and by slowly rotating the scanner. Clean the shaded portion of the upper drum tape transport surface, shown in the figure, in a circumferential direction two or three times.

Perform the cleaning with every 1 month.

Tool: Cleaning piece

Part Number: 2-034-697-00

Note 1: Be sure to clean the rotary head and the upper drum tape running surface in a circumferential direction. Do not move the cleaning piece in a vertical direction because it may damage the head. Do not use a cotton swab for cleaning.

Note 2: Clean the tape running surface of the upper drum carefully, especially the lower edge portion.

2. Always wipe the parts with a dry piece after cleaning.

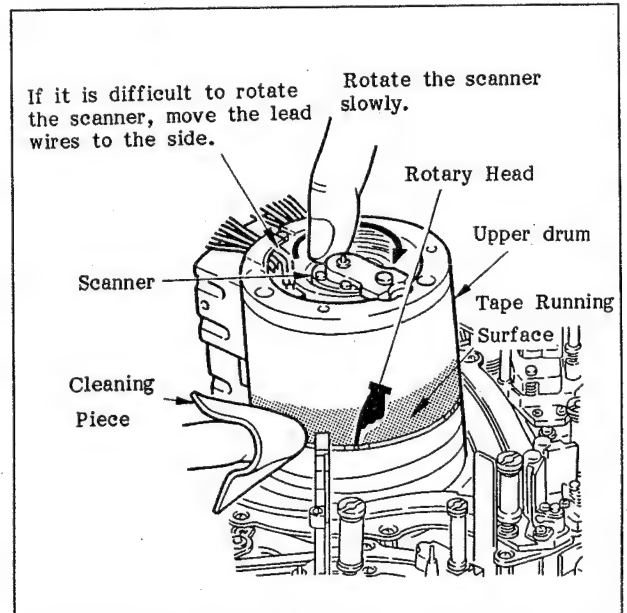

Fig. 5-1 Cleaning the Rotary Head and the Upper Drum Tape Running Surface

(How to Use the Cleaning Cassette)

Tool: Cleaning cassette (DCM-75L)
 Part Number: 8-831-089-0

1. Use the cleaning cassette when the rotary head becomes clogged and it cannot be corrected by cleaning the head, or when the error rate becomes very high. Never use the cleaning cassette in other cases. It may shorten the life of the rotary head considerably.
2. The time for one cleaning must be less than 5 seconds in REC mode. Never use the cleaning cassette in a mode other than the REC mode. If the clogged head is not corrected or the error rate is not improved by one cleaning, perform the procedure shown in the flowchart below.
3. A cleaning cassette should be used only once. Never rewind it and reuse.
4. Use the cleaning cassette as shown in the flowchart below.

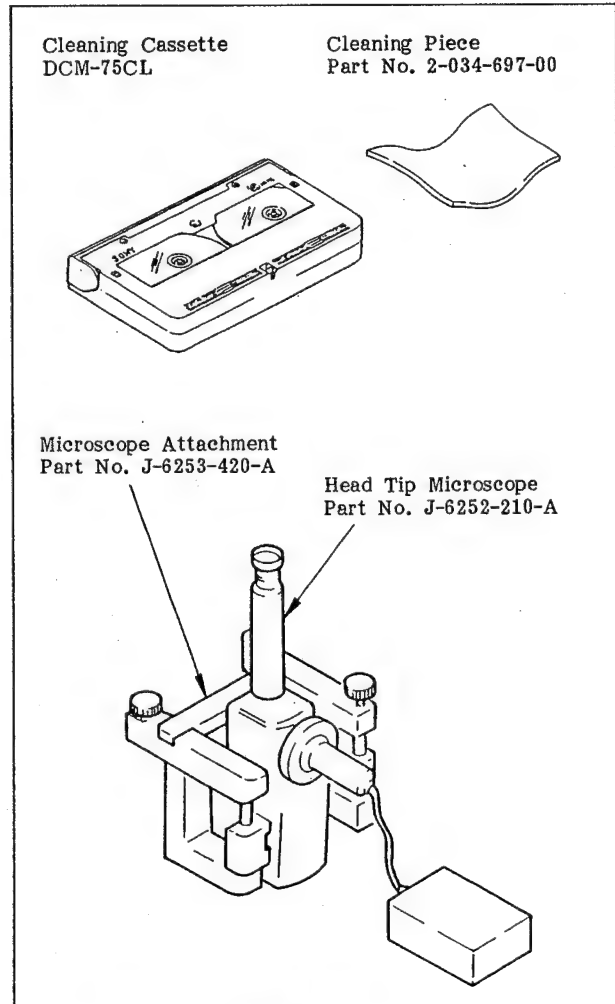
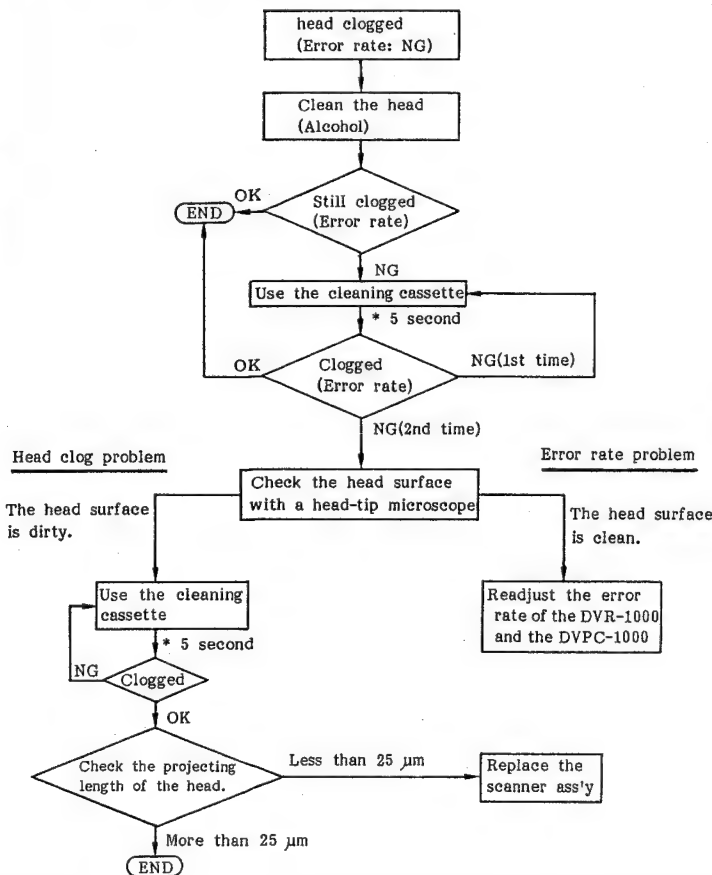
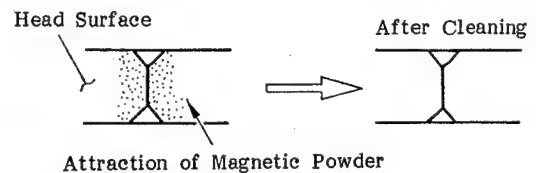

Fig. 5-2 Cleaning Tool

(Ref.): It is recommended that the head-tip microscope be used to check if the head has been cleaned thoroughly.

Tool: Head-tip microscope
 Part Number: J-6252-210-A
 Tool: Microscope attachment
 Part Number: J-6253-420-A

These tools are used to observe the head surface. The following check can be performed.



(Cleaning the Lower Drum Read Surface and the Tape Running Surface)

1. If magnetic powder is attracted to the drum read surface, shown in Fig. 5-3, it may affect the tracking. Remove the magnetic powder with a bamboo skewer (or equivalent) by moving it along the drum read surface, as shown in the figure.
2. Clean the drum read surface and the lower drum tape transport surface with a cleaning piece soaked with alcohol.

Tool: Cleaning piece

Part Number: 2-034-697-00

Perform the cleaning with every 1 month.

3. After cleaning, be sure to clean it with a dry piece a few times.

(Cleaning the Tape Running System)

1. Clean the portions marked by  shown in Fig. 5-4, with a cloth (or gauze) moistened with alcohol.

Perform the cleaning with every 1 month.

Note: Since tape powder or back-coating material sticks easily to the entrance slant guide and the exit slant guide, remove it sufficiently, but do not press the cloth too strongly against the entrance and exit slant guides when cleaning.

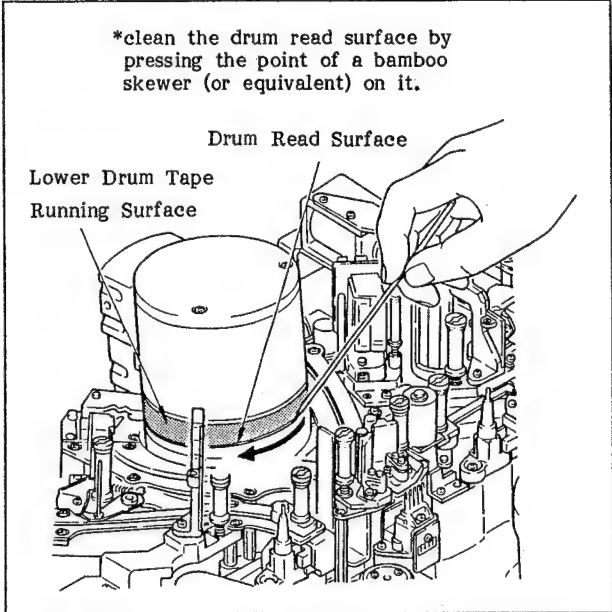

Fig. 5-3 Cleaning the Lower Drum Read Surface and the Tape Running Surface

If the slant guides move, it may change the tape running.

2. After cleaning, be sure to clean it with a dry piece a few times.

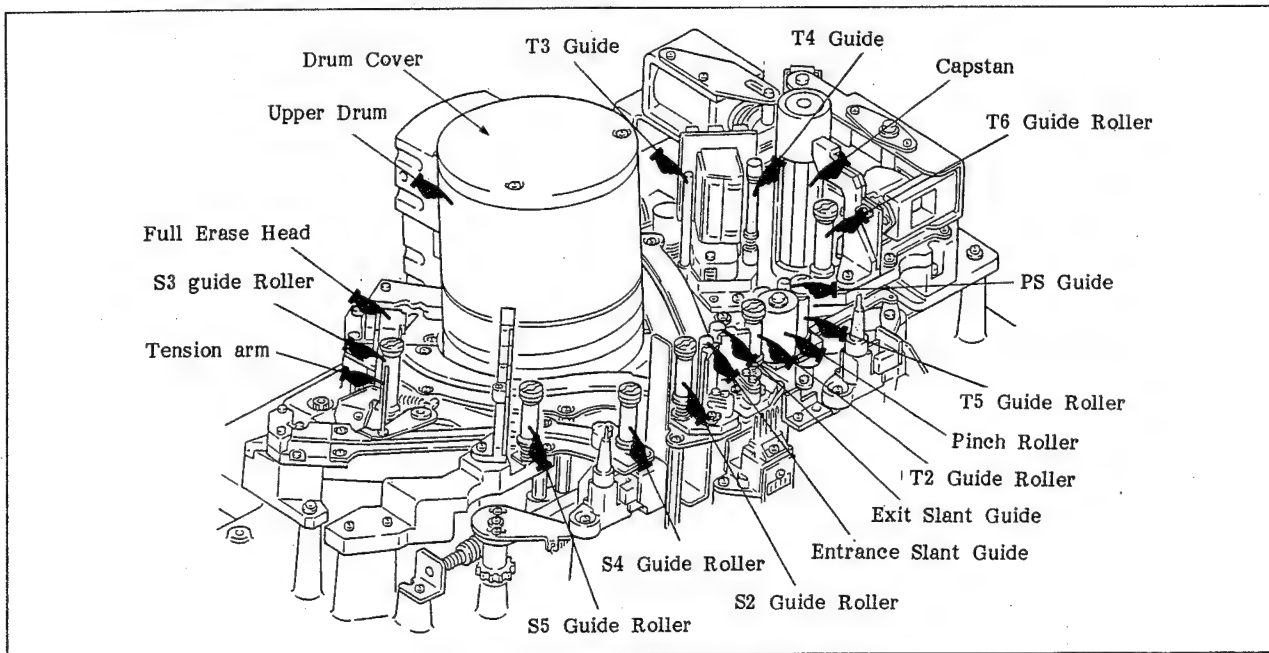

Fig. 5-4 Cleaning the Tape Running System



(Cleaning the Stationary Head)

1. If magnetic powder sticks to the gap between the Audio CTL Erase Head and the Audio CTL R/P Head, it may cause recording/playback errors. Clean the tape running surface of the head with a cloth (or gauze) moistened with alcohol.
2. After cleaning, be sure to clean it with a dry piece a few times.

Perform the cleaning with every 1 month.

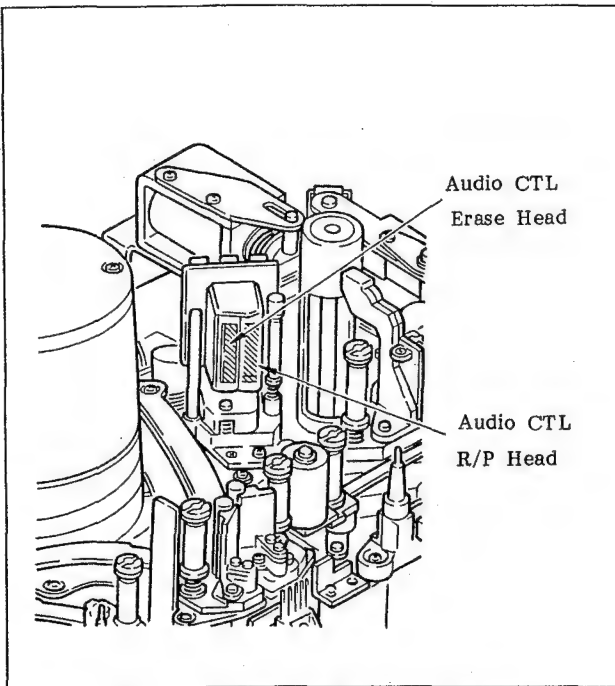

Fig. 5-5 Cleaning the Stationary Head

(Cleaning the Slider Rails)

If large foreign matter sticks to the slider rail surface, shown in Fig. 5-6, it may hinder the final positional regulation of the slider block, resulting in a tracking error. Clean the slider transport surface, shown in the figure, with a cloth (or gauze) moistened with alcohol.

Perform the cleaning with every 1 month.

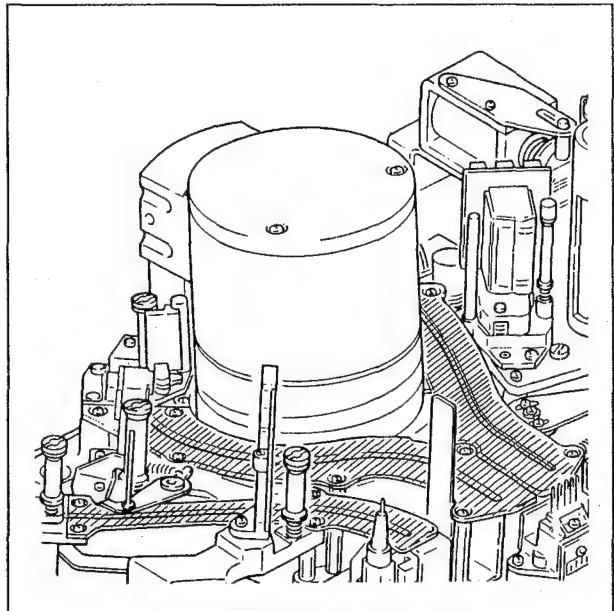

Fig. 5-6 Cleaning the Slider Rails

(Cleaning the slider Guide Blocks)

Basic Knowledge

A. If there is dust on the slide surfaces of the S drawer block, the entrance slant guide block, and the exit slant guide block, marked by shown in Fig. 5-7, the guide blocks may not move smoothly and positioning errors may occur. Clean the slider guide blocks by the following procedure.

Perform the cleaning with every 1 month.

B. Prepare the following tool.

Tool: Cleaning band

Part Number: 3-735-152-01

1. Remove the grease cover shown in Fig. 5-8.
2. Rotate the threading motor manually in the direction of the arrow to move the guide blocks to the positions shown in Figure 5-9.

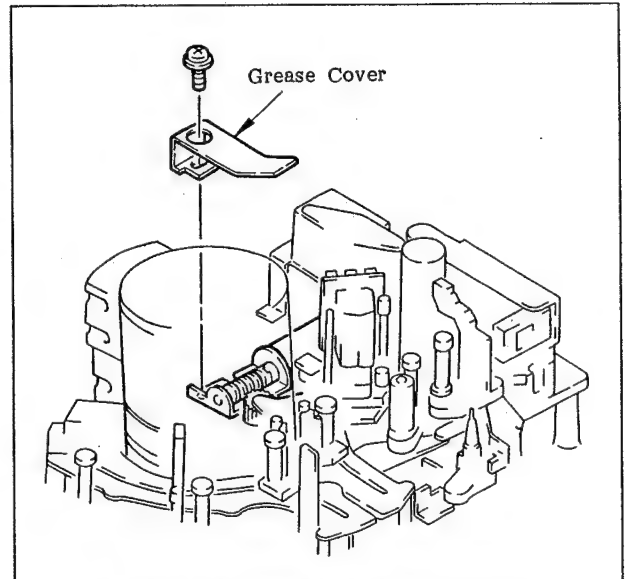

Fig. 5-8 Removing the grease cover

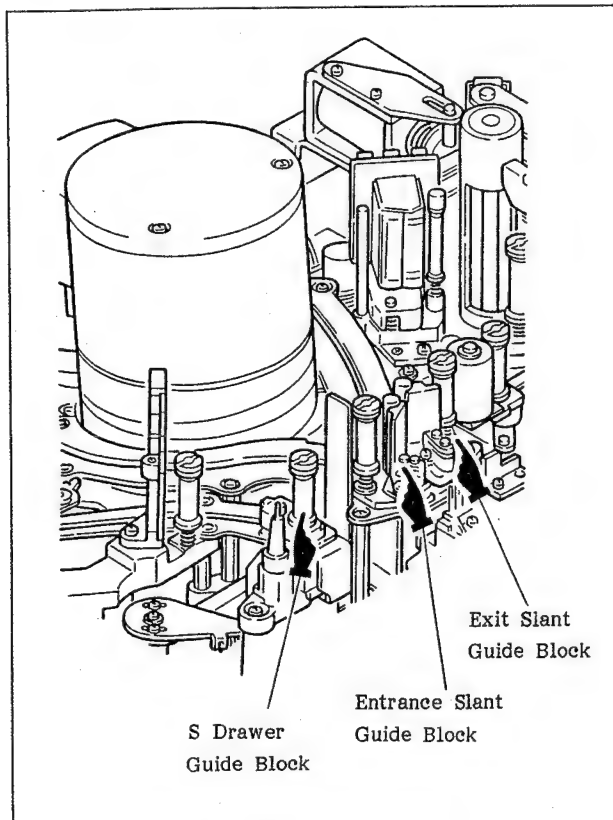

Fig. 5-7 Slider Guide Blocks

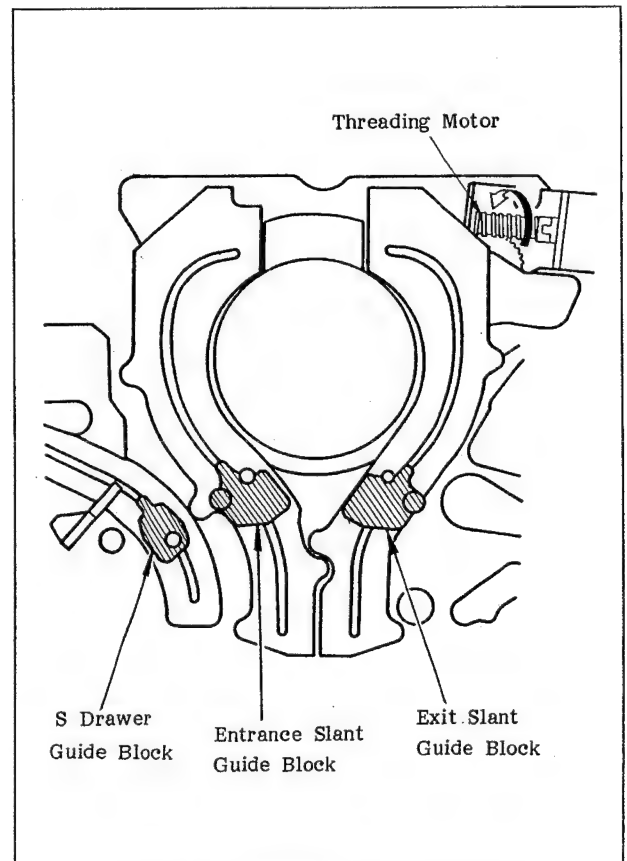

Fig. 5-9 Positioning the Guide Blocks

3. Push the S2, T2, and S4 guide rollers of the guide block lightly, as shown in fig. 5-10, to insert a cleaning band between the rail and the guide block.

Note 1: Push the guide rollers lightly. If they are pushed too hard, the slant of the rollers may change.

Note 2: Do not push the entrance slant guide or the exit slant guide.

4. Pull out the cleaning band in the direction of the arrow while holding down the shaded portion of the guide block shown in Fig. 5-11. Clean all the other slider guide blocks in a similar manner.

Note 1: Perform the cleaning work carefully so as no to touch the rotary head.

Note 2: It is recommended that a cleaning band be used only once.

5. Wipe the tape running surface of the tape guide with a dry cloth after cleaning.

6. Perform Section 5-2-2 "Tacking Check."

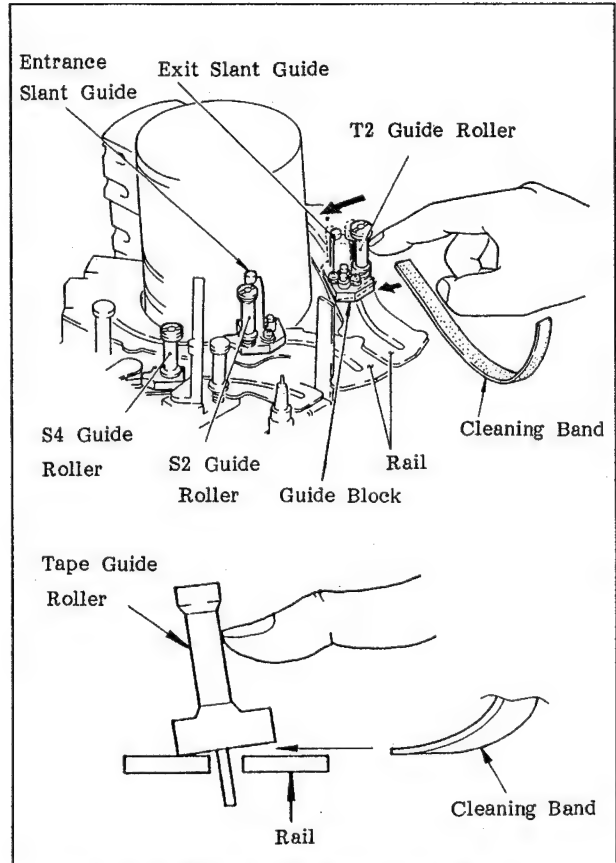

Fig. 5-10 Cleaning the Slider Guide Blocks (1)

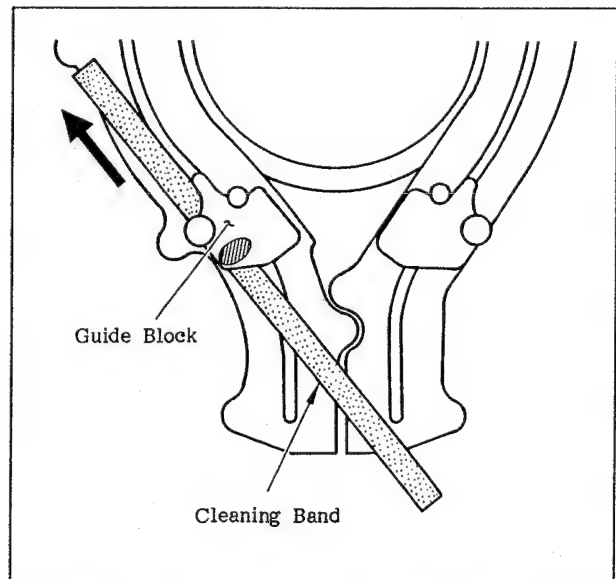

Fig. 5-11 Cleaning the Slider Guide Blocks (2)

(Cleaning the air filter)

The air filter is mounted to the connector panel of DVR-1000 for trapping dust. Before the filter is contaminated heavily, it is recommended to clean the filter as instructed below.

Perform cleaning every month.

- . Removal of air filter
Loosen the setscrew shown in Fig.5-12-1, open the filter cover and remove the air filter.
- . Cleaning of air filter
Suck dust with the aid of a vacuum cleaner.

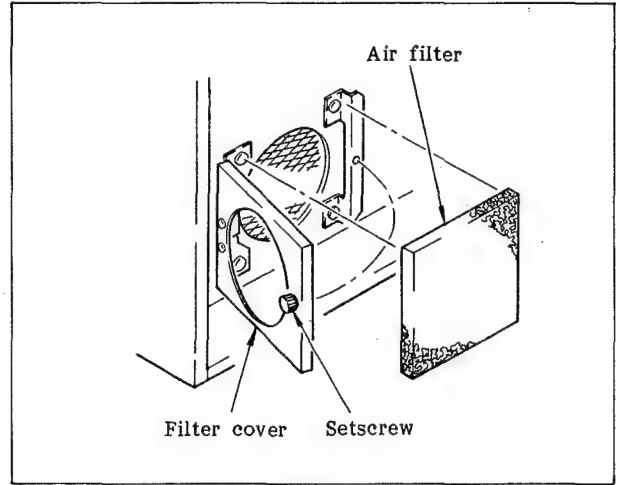

Fig. 5-12-1 Cleaning the Air Filter

(Cleaning the DC Fan Motors)

Since dust sticks easily to the DC fan motor shown in Fig. 5-12, especially to the fan cover, because of its characteristics, clean it by the following procedure.

Perform the cleaning with every 1 month.

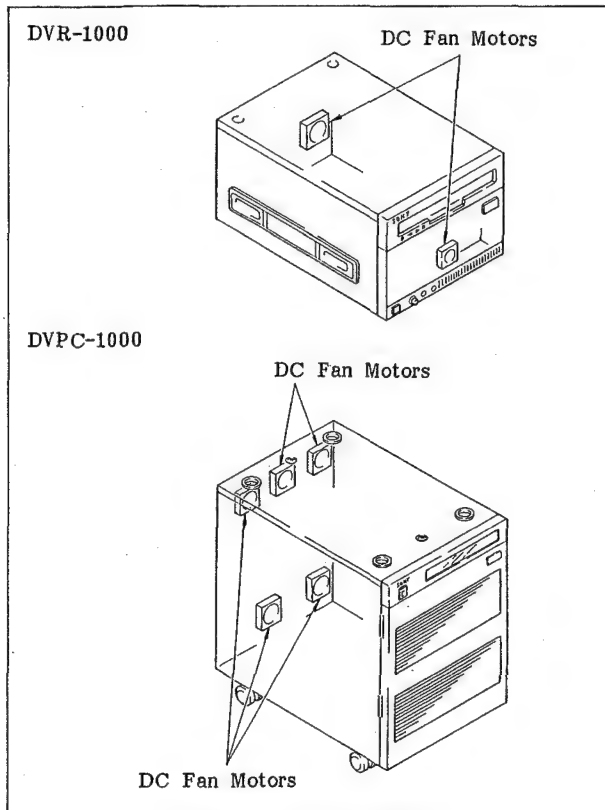

Fig. 5-12 DC Fan Motors

- . Cleaning the fan covers
Remove the dust with a brush and a vacuum cleaner, as shown in Fig. 5-13 (a).
- . Cleaning the fins.
Clean the fins of the fan motors, as shown in Fig. 5-13 (b). (Refer to Section D for disassembling.) The fins should be cleaned in the same way as the fan covers.

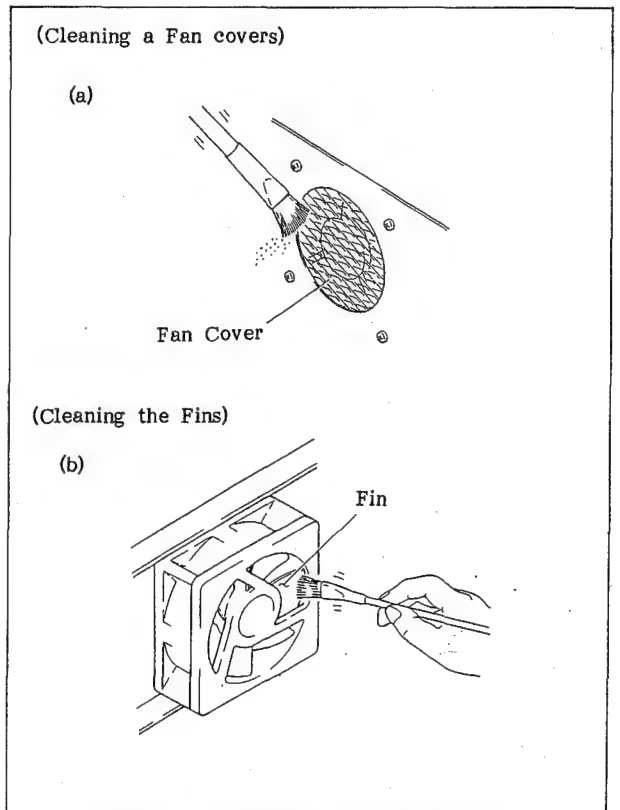

Fig. 5-13 Cleaning a DC Fan Motors

(Cleaning the Cassette Compartment)

Clean the cassette compartment, shown in Fig. 5-14, by the following procedure. Remove the top plate to clean the cassette compartment.

Perform the cleaning with every 1 month.

Remove the dust from the compartment, shown in Fig. 5-15, with a cloth (or gauze) through the cassette insertion slot of the cassette compartment.

Note: Be careful when cleaning that you do not push the compartment, cassette cover, and the flexible card wire too hard.

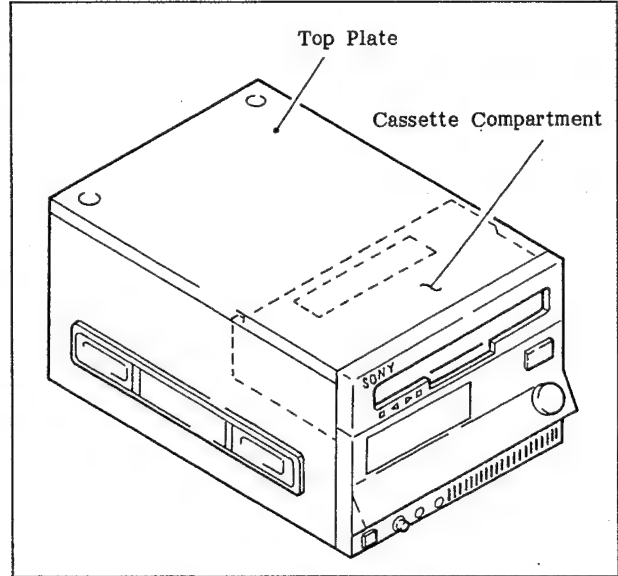

Fig. 5-14 Cassette Compartment

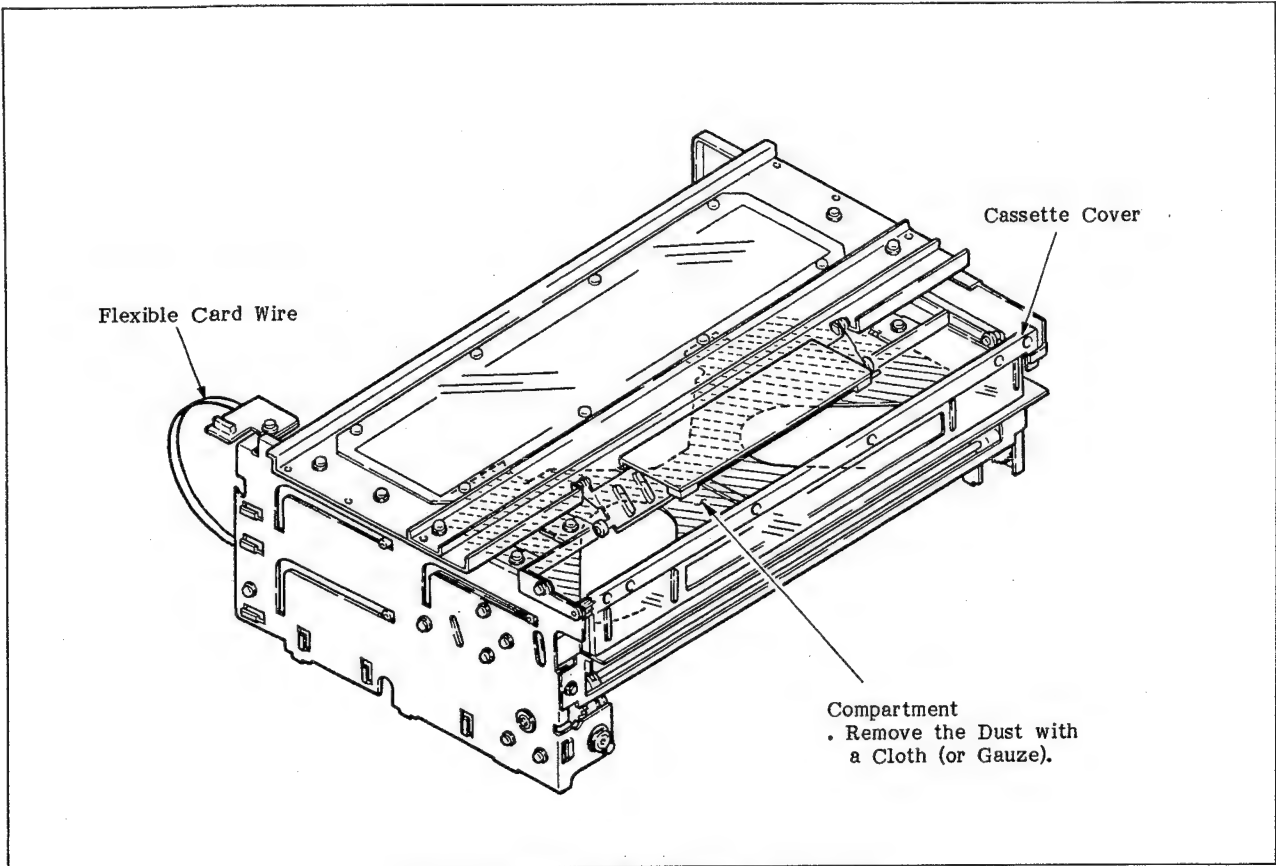

Fig. 5-15 Cleaning the Cassette Compartment

5-2-2. Tracking Check

Basic Knowledge

A. Prepare the following alignment tapes for making the adjustments.

alignment Tape: DR-5-1A

Part Number: 8-90-070-01 (525/60)

Alignment Tape: DR-5-1B

Part Number: 8-960-070-51 (625/50)

B. In case the scanner assembly has just been replaced, make sure to perform a running-in operation in REC mode for about 20 minutes, by using a commercially available cassette tape, before performing the tracking check.

1. Connect an oscilloscope to TP8 (A ch) of the RF-15 board, then connect TP6 of the CD-35 board to the RF-15 board as the trigger input.
2. Playback the tape path check portion of the alignment tape in NORMAL PLAY mode.
3. Confirm that the tape touches the upper flanges of the S2 and T2 guides lightly and that it does not curl. If this is not satisfied, perform the tape path adjustment according to section 9-2.
4. Adjust the RF amplitude until it becomes maximum by turning the tracking knob.
5. Confirm that the RF waveform meets the standard shown in Fig. 5-4. If it does not meet the standard, perform the tracking adjustment according to section 9-5-2.
6. Confirm that the RF waveform changes evenly when the tracking knob is turned back and forth. If it does not, perform the tracking adjustment according to section 9-5-2.
7. Adjust the RF amplitude until it becomes maximum again by turning the tracking knob. Then, push the tracking knob in. Confirm that the RF waveform does not change at this time. If it does, perform the CTL head position adjustment according section 9-8.

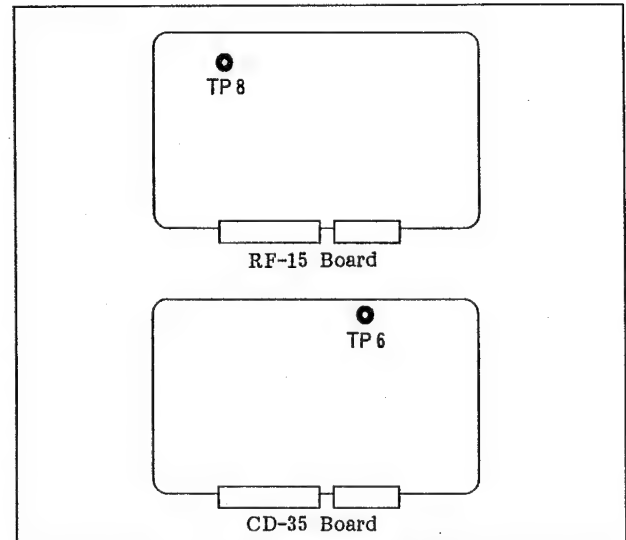

Fig. 5-16 RF-15/CD-35 Board

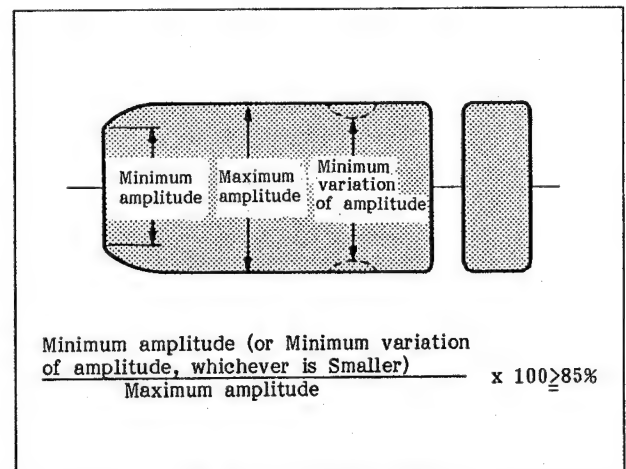

Fig. 5-17 Tracking Check

5-2-3. Head Projection Check

Basic Knowledge

- A. It is possible to record and play back if the heads project more than 25 μm .
- B. Prepare the following tool for measuring the amount of head projection.
 - . Head projection measurement gauge:
Part No.: J-6251-120-A

(Using the Head Projection Measurement gauge)

- . Perform the following before measuring the length of the heads projections.
 1. Hold the probe of the head projection measurement gauge with your finger, as shown in Fig. 5-19 (a), and check that it drops by its own weight when you remove your finger, as shown in Fig. 5-19 (b).
If it does not drop, clean the probe.
 - a. Move the dial gauge probe as shown in Fig. 5-20 and remove the probe.
 - b. Clean the probe and the probe mounting hole with a cleaning piece soaked with alcohol.
 - c. Insert the probe into the probe mounting hole and slide it in and out approximately 10 times.
 - d. Return the dial gauge probe to its original position.
 - e. Perform the checking of step 1.
 2. If foreign matter sticks to the contact arm of the head projection length measuring tool, it may damage the heads when making the measurements. Be sure to clean the tool with a cloth (or gauze) moistened with alcohol before measuring.

Note: Handle the head projection measurement gauge carefully because the correct measurements may not be obtained if the contact arm is damaged or broken.

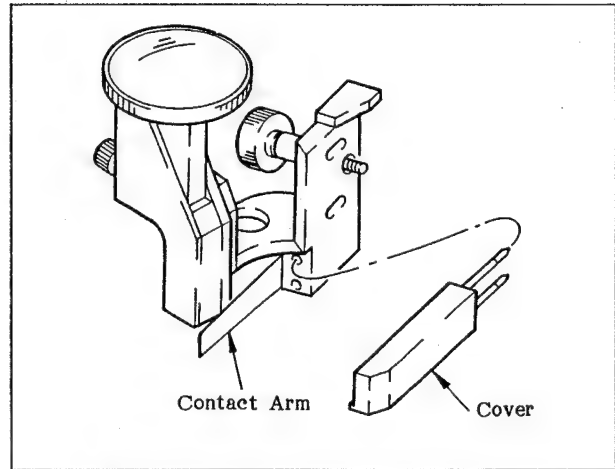

Fig. 5-18 Head Projection Measurement Gauge

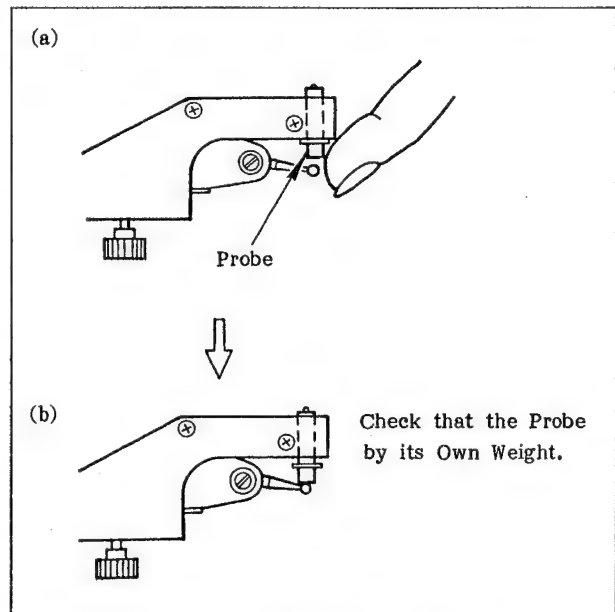

Fig. 5-19 Checking the Probe

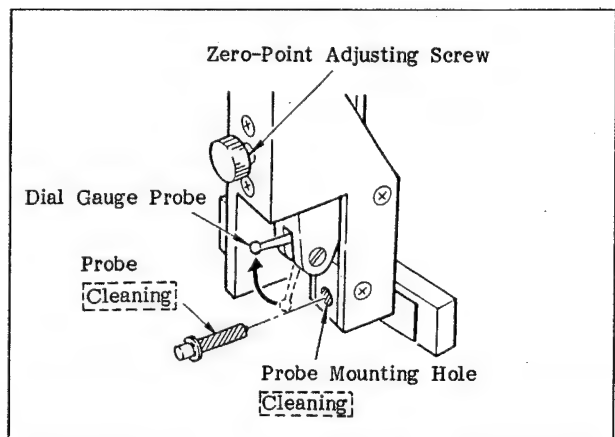

Fig. 5-20 cleaning the Probe

(Head Projection Check)

1. Remove the two screws that hold the drum cover, and then remove the cover.
2. Remove the cover of the head projection measurement gauge.
3. Turn the zero-point adjusting screw of the tool two to three times counterclockwise.
4. Rotate the scanner so that the rotary head will not touch the tool when it is attached.

Note: Do not touch the rotary head when mounting the tool because the rotary head may be damaged.

5. Mount the head projection measurement gauge in the position shown in Fig. 5-21. Clean the drum support and the mounting surface of the tool with a cloth (or gauze) moistened with alcohol before mounting it. After cleaning, tighten the set screws while pushing the tool down and in the direction of the upper drum at the same time so that there is no gap between the drum support and the tool, as shown in Fig. 5-22.

Note: After mounting the tool, verify again that there is no gap between the drum support and the tool at the four places indicated by the * mark in the figure. If there is a gap, the measurement will not be made correctly.

6. After mounting, verify that the lower edge portion of the upper drum and the upper edge of the contact arm of the head projection measurement gauge satisfy specification A.

Spec. A: between 0.1 mm and 0.5 mm

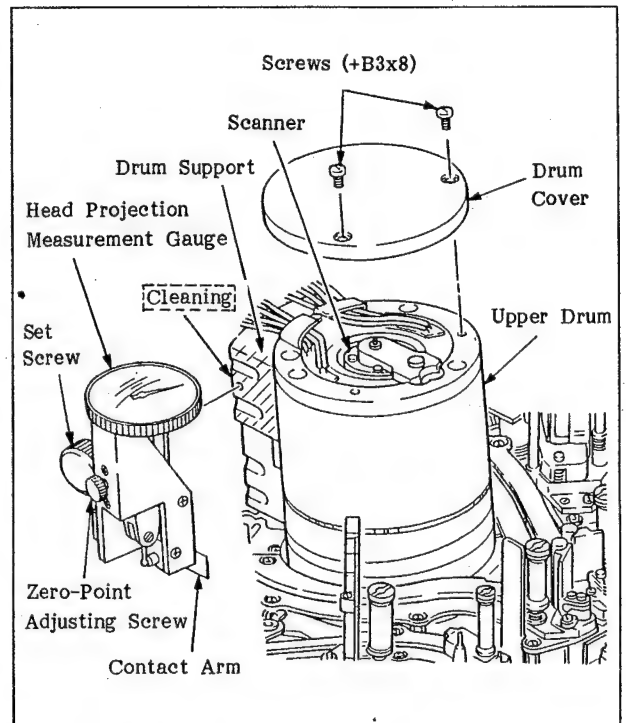
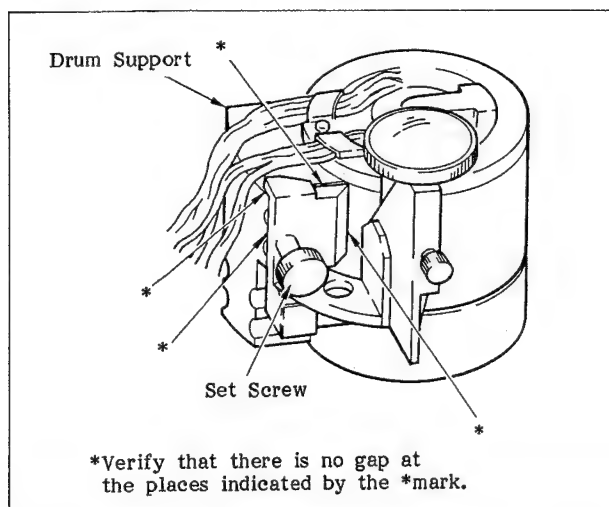

Fig. 5-21 Head Projection Check (1)

If they do not satisfy the specification, perform step 5 again.



*Verify that there is no gap at the places indicated by the *mark.

Fig. 5-22 Head Projection Check (2)

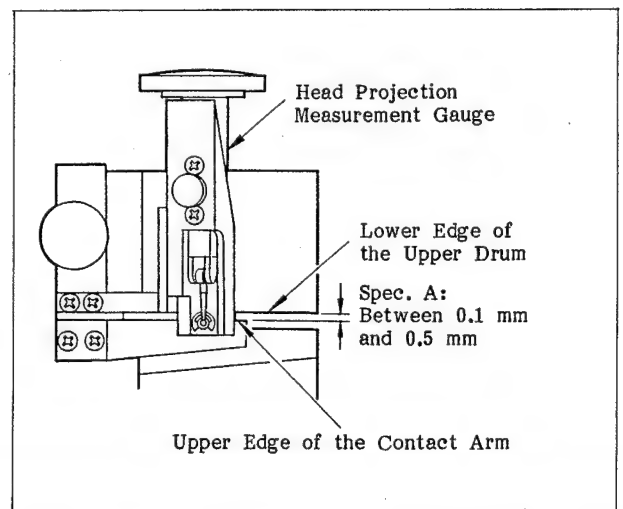

Fig. 5-23 Head Projection Check (3)

7. Turn the zero-point adjusting screw clockwise and stop in the position where the pointer of the dial gauge starts moving. Verify that the dial gauge probe shown in Fig. 5-24 is in contact with the probe and the that tip of the probe is in contact with the contact arm.
8. Turn the zero-point adjusting screw again until the pointer of the dial rotates 180 degrees, as shown in Fig. 5-25 (a).
9. Turn the dial as shown in Fig. 5-25 (b) so that the pointer of the dial is at the zero point.
10. Verify that the pointer returns to the zero point when the scanner is rotated slowly counterclockwise by one turn.
11. Rotate the scanner slowly and verify that the length of all the projections of the heads is 25 μm or more. If that of any one of the heads is less than 25 μm , it is recommended that the scanner assembly be replaced with a new one.
12. Turn the zero-point adjusting screw counterclockwise to separate the dial gauge probe from the probe.
13. Slowly turn the scanner counterclockwise. When the rotary head comes to the position where it does not touch the tool, remove the tool from the drum support.

Note: If the tool touches the rotary head when removing it, it may damage the rotary head; therefore, be very careful when removing the tool.
14. Put the cover on the contact arm of the tool.
15. attach the drum cover on the upper drum with the two screws (+B3x8).

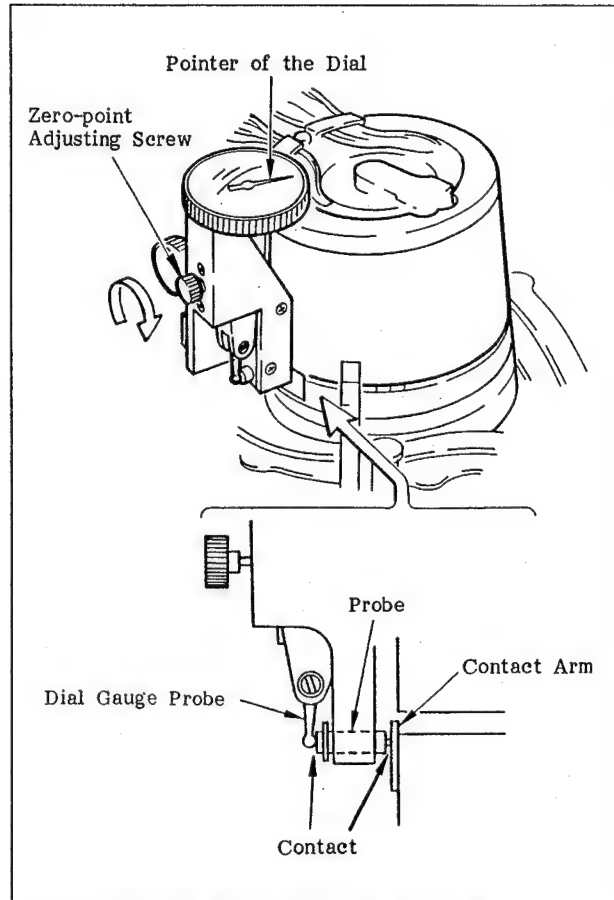

Fig. 5-24 Head Projection Check (4)

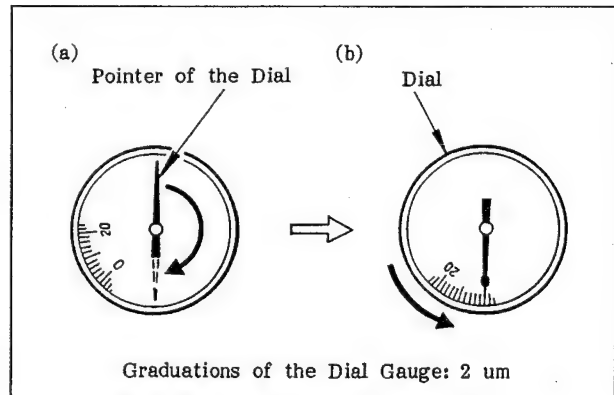
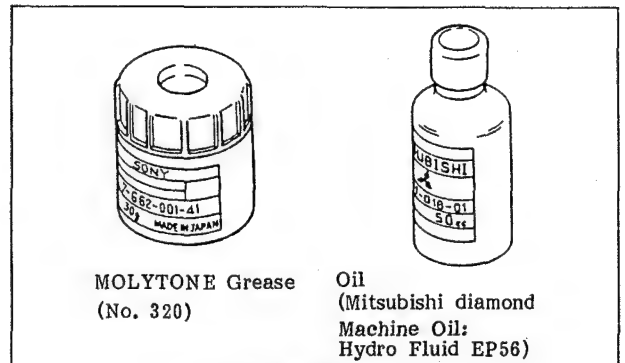

Fig. 5-25 Head Projection Check (5)

5-2-4. Apply Grease and Oil

Basic Knowledge

- A. The oil and grease are recommended to be applied at regular intervals in order to obtain maximum performance and longer life of the unit. This section describes the portions where are required to be applied.
- B. Grease and oil
MOLYTONE grease (No. 320)
Part Number: 7-662-001-41
Oil (Mitsubishi Diamond Machine Oil: Hydro Fluid EP56)
Part Number: 7-661-018-01



Grease and Oil

(Cassette Compartment Block)

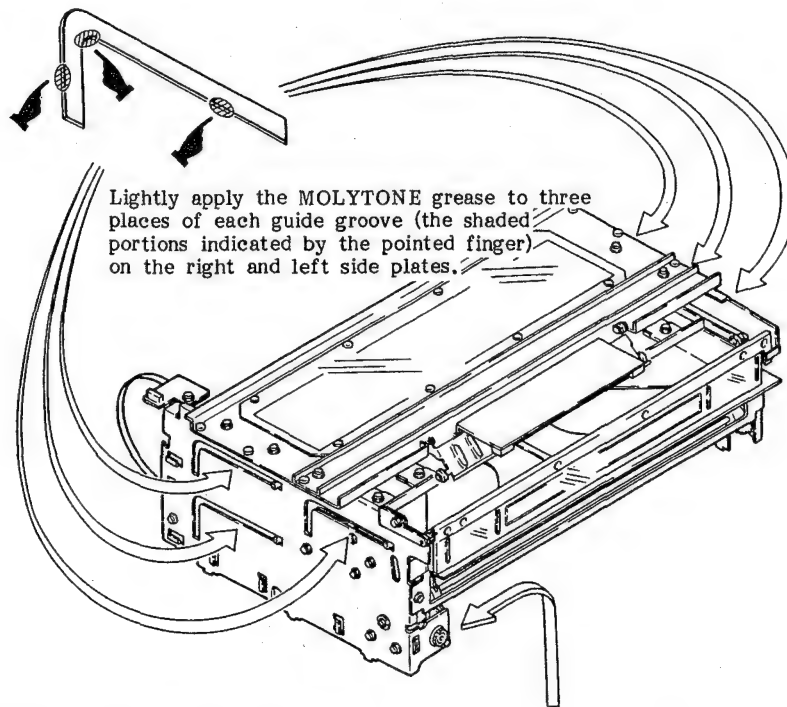

Lightly apply the MOLYTONE grease to the worm gear in the cassette compartment.

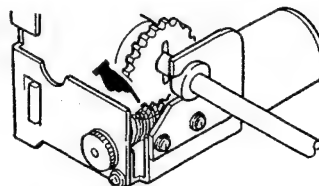

(Reel Shift Motor Block)



5. PERIODICAL INSPECTION AND MAINTENANCE

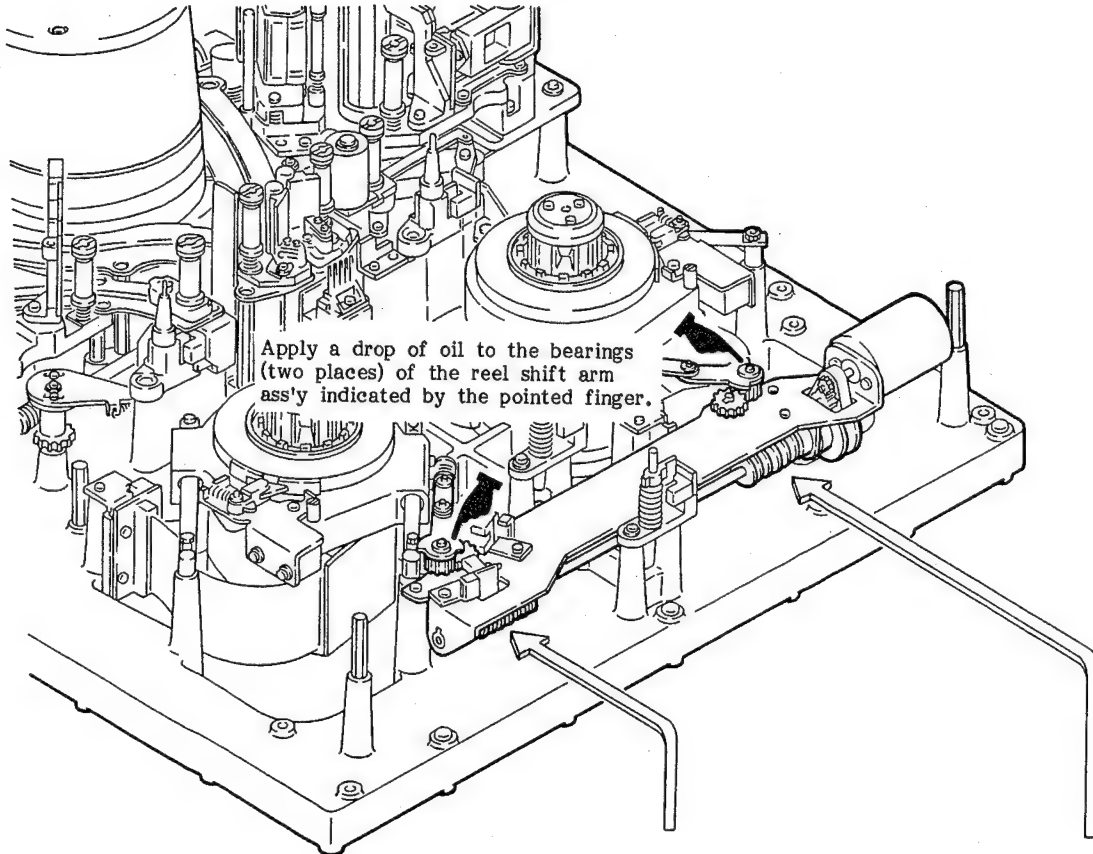

Apply a drop of oil to the bearings
(two places) of the reel shift arm
ass'y indicated by the pointed finger.

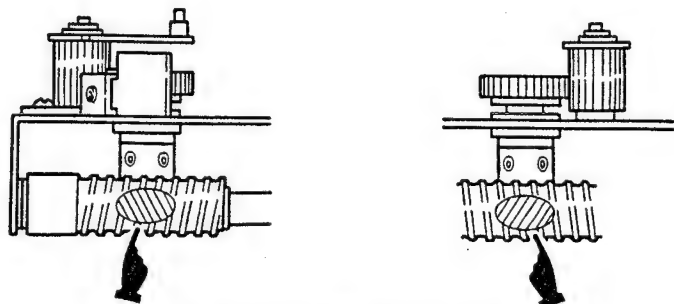

Lightly apply the MOLYTONE grease to
the worm gears (two places) of the reel
shift drive shaft ass'y (the shaded portions
indicated by the pointed finger).

(T.T.P Block)

Gear Box Ass'y

Lightly apply the MOLYTONE grease to the worm gear of the gear box ass'y (the shaded portion indicated by the pointed finger).

Note: Remove the grease cover when applying the grease.

Pinch Plunger Ass'y

Lightly apply the MOLYTONE grease to the groove of the guide plate of the pinch plunger, indicated by the pointed finger.

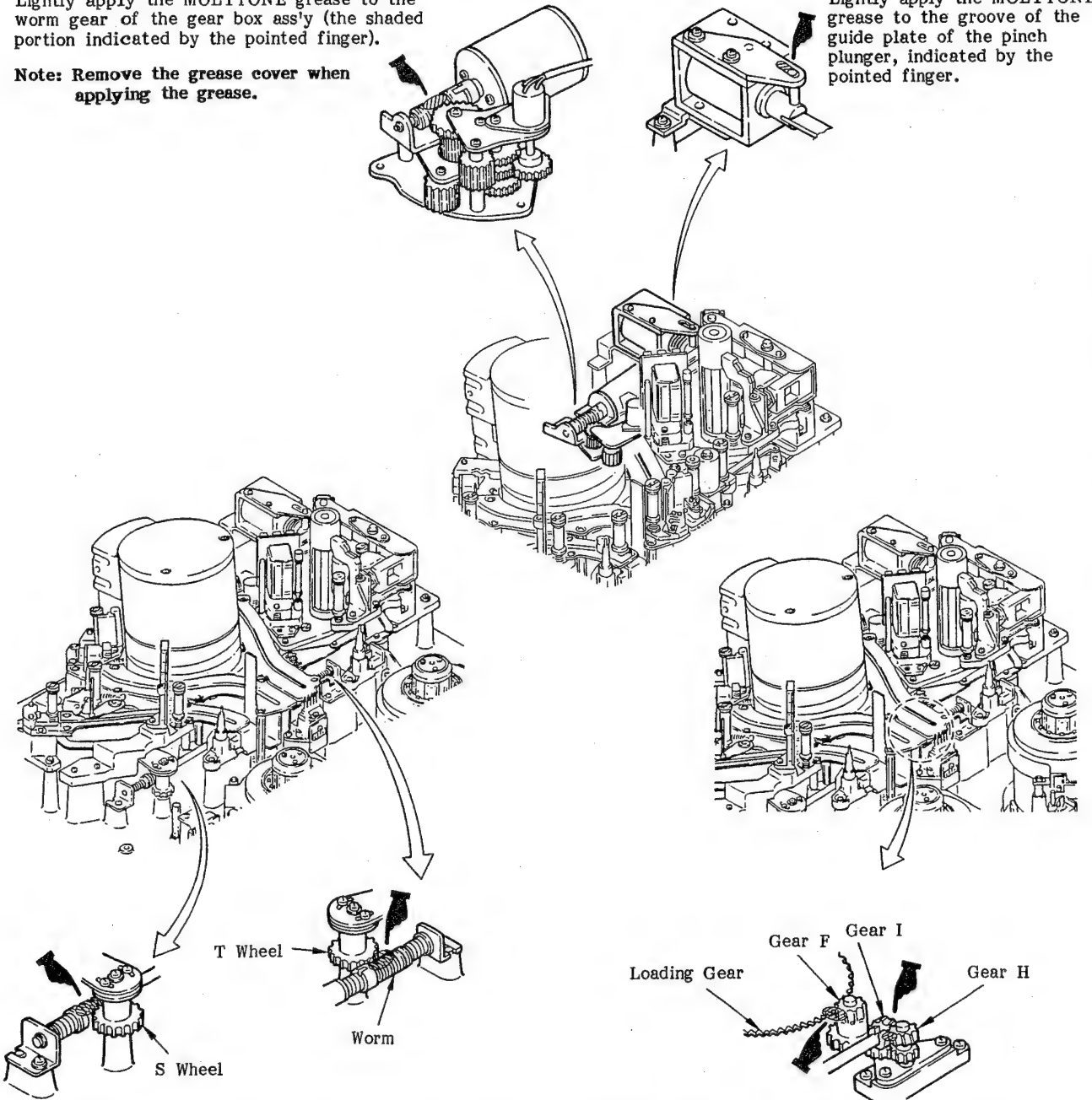

Drive Shaft Ass'y

Lightly apply the MOLYTONE grease to the worm gears (two places) of the drive shaft assembly (the shaded portions indicated by the pointed finger).

Loading Gear

Lightly apply the MOLYTONE grease to the shaded portions of the loading gear, gear F, gear I, and gear H, indicated by the pointed finger.

(Slider Guide Block)

. Apply the grease to the slider guide lock every 2500 hours by the following procedure.

- ① Lightly apply the MOLYTONE grease to the portion A of the entrance slant guide block, of the exit slant guide block, and of the S drawer block, as shown in Fig. (a).

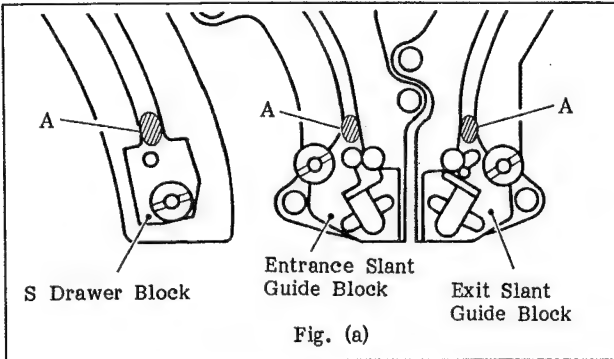

- ② Lightly apply the MOLYTONE grease to the portion B inside the V groove of the retainer block of each guide block.

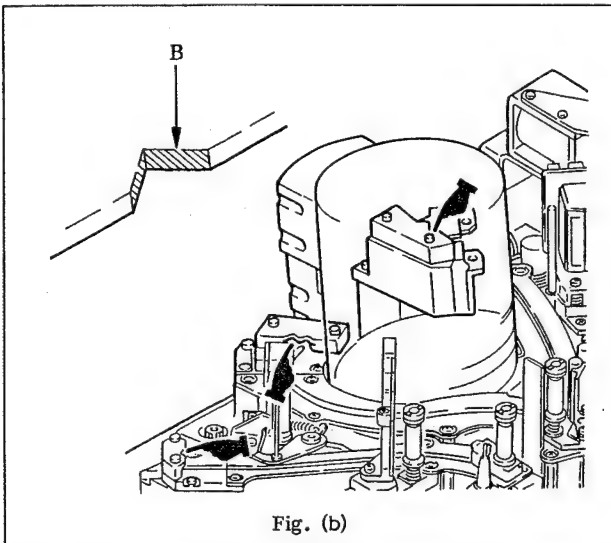

- ③ Rotate the threading motor manually so that the threading and unthreading conditions are repeated 10 times.

Note: Keep a slight distance between the guide block and the retainer block for unthreading.

- ④ Set the unit in unthreading condition and wipe the MOLYTONE grease off the portions C of the entrance slant guide block, the exit slant guide block, and the S drawer block, shown in Fig. (c), with a cotton swab or a cloth.

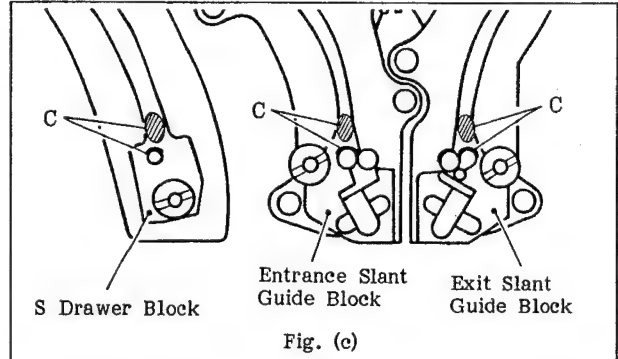

- ⑤ Then wipe the MOLYTONE grease off each retainer block shown in Fig. (d).

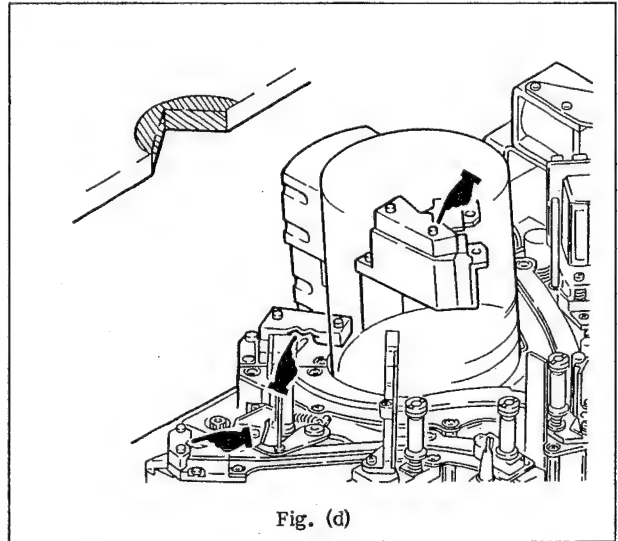

- ⑥ Repeat the threading and unthreading conditions two or three times.

- ⑦ Repeat steps ④, ⑤, and ⑥.

SECTION 6 PARTS REPLACEMENT AND ADJUSTMENT

6-1. SCANNER ASSEMBLY

Background Knowledge

Use the following tools for replacement.

- PRT Harness Guide: J-6252-310-A
- Drum Eccentric Adjusting gauge: J-6251-110-A
- Torque Driver 12kg-cm: J-6252-520-A
26kg-cm: J-6252-530-A
- Torque Driver Bit Set: J-6252-540-A

6-1-1. Replacement of the Scanner Assembly

Disassembly

1. Put a mark on the UDS plate of the drum support and the upper drum so that the upper drum can be reassembled in its original position after it has been disassembled.
2. Unscrew the three screws that fix the drum support and the upper drum, and then lift the upper drum straight up.

Note: Be careful not to hit the bottom edge of the upper drum against the head.

3. Mount the head protect cover on the scanner assembly and fasten it with four screws (+B2x3).

Note: If there is no spare head protect cover, use a head protect cover that is attached to a replacement

scanner assembly. After you have finished using the head protect cover, make sure to re attach it to the replacement scanner assembly.

4. Disconnect the two PRT connectors and unscrew the two screws that fix the scanner assembly. Then, remove the scanner assembly as shown by the arrows in Fig. 6-3.

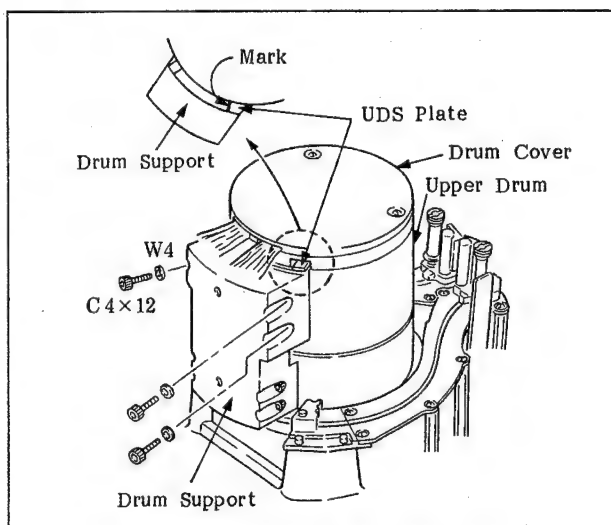

Fig. 6-1 Disassembling the Upper Drum

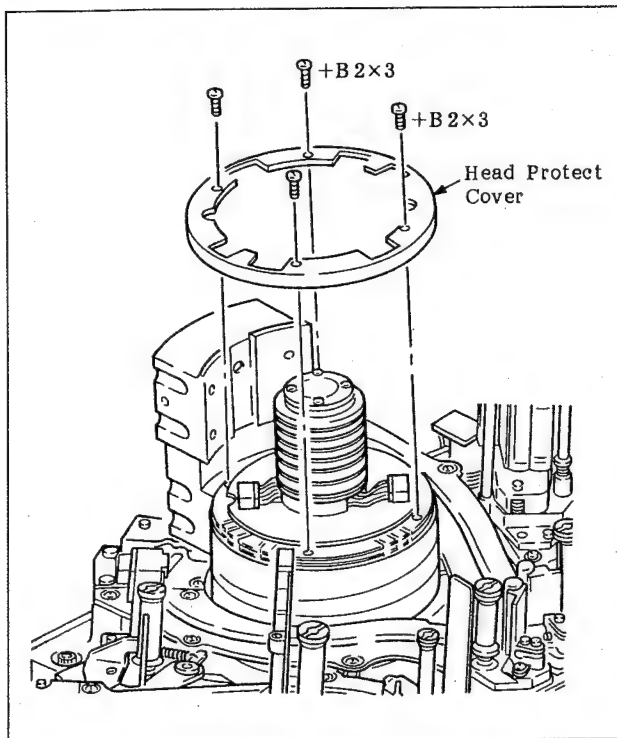

Fig. 6-2 Mounting the Head Protect Cover

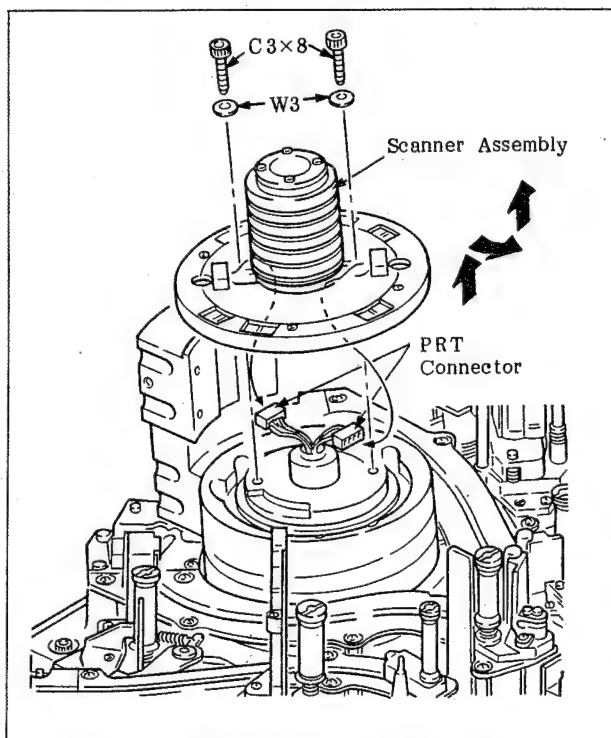

Fig. 6-3 Disassembling the Scanner Assembly



Mounting the Scanner Assembly

Note: Confirm that the protect cover is mounted on the replacement scanner assembly before performing the next step.

5. Clean the flange surfaces of the drum assembly and the scanner assembly that will be in contact with each other.
6. Insert the PRT harness guide gauge in the two PRT connectors of the drum assembly. Then, pass the gauge string through the window of the replacement scanner assembly and place the scanner on the flange of the drum assembly in the reverse sequence of the removal procedure. Place the scanner assembly on the balance board so that the white line marked on the balance board matches the white connector of the scanner.

Note: Do not remove the head protect cover mounted on the replacement scanner yet.

7. Fasten the scanner assembly with two screws (C3x8) and tighten them slightly so that the assembly can move. Then, remove the PRT harness guide jig.
8. Insert the two PRT connectors in the specified positions.

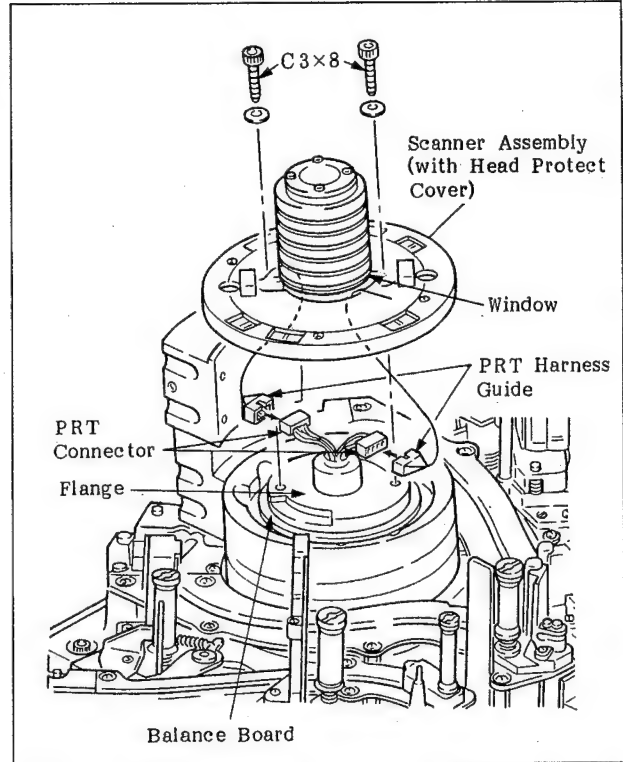

Fig. 6-4 Mounting the Scanner Assembly

Eccentric Adjustment

9. Remove the screw (PS3x8) securing the full-erase head to mount the eccentric adjustment gauge (one PS3x8).
10. Mount the eccentric adjustment gauge by loosening its zero-point adjusting screw and by rotating the dial gauge counterclockwise.
11. Cause the measuring probe to contact the scanner by rotating the dial gauge clockwise.
Note: Ensure that the measuring probe contacts the second core of the scanner from the bottom.
12. Adjust the zero-point by turning the zero-point adjusting screw so that the scale of the gauge points to zero.
13. Rotate the scanner slowly in the direction shown in the figure and confirm that the deflection of the pointer is less than 2 μ m.
If its deflection is more than 2 μ m, adjust it according to the following procedure.
 - a. Rotate the scanner slowly until the deflection of the pointer becomes maximum.
 - b. Push the rotary transformer portion around the place where the probe touches toward the center with your fingers so that the deflection of the pointer becomes one-third of the maximum value.
 - c. Then, slowly rotate the scanner again and check that the deflection of the pointer is within 2 μ m.
If it is over 2 μ m, repeat the procedure from step a.
14. Tighten the two screws that you tightened slightly in step 7 to fasten the scanner assembly firmly in place.
Note: Tighten the two screws with a torque of 6kg-cm.
15. Confirm again that the deflection of the pointer is within 2 μ m. If it is not, loosen the two screws that fix the scanner assembly and repeat the procedure from step 13 a.
16. Rotate the zero-point adjusting screw counterclockwise. Then, remove the tool after fully rotating the dial gauge counterclockwise.
17. Replace the full-erase head in its original position.

Mounting the Upper Drum

18. Unscrew the four screws and remove the head protect cover as shown by the arrows in Fig. 6-3.
Note: Be careful not to damage the head when removing the head protect cover.
19. Place the scanner on the upper drum. Be careful not

to damage the head. Then, align the upper drum to the point marked in step 1 and fasten it with the three screws (C4x12).

Note: Tighten the set screws with a torque of 16kg-cm.

Adjustment of Full-erase Head

20. Thread the tape by loading an M or L cassette tape.
21. Adjust the full-erase head so that the tape contacts the head at its center, and tighten one screw (PS3x8).

Note: Tighten the screw with a torque of 8kg-cm.

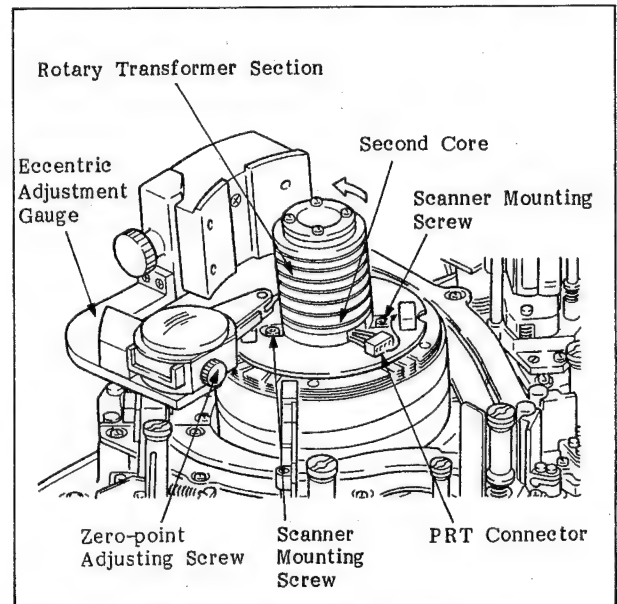

Fig. 6-5-1 Eccentric Adjustment

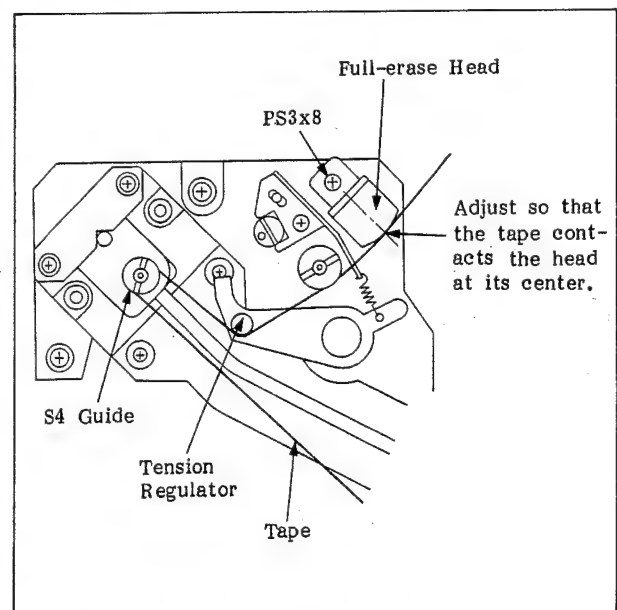
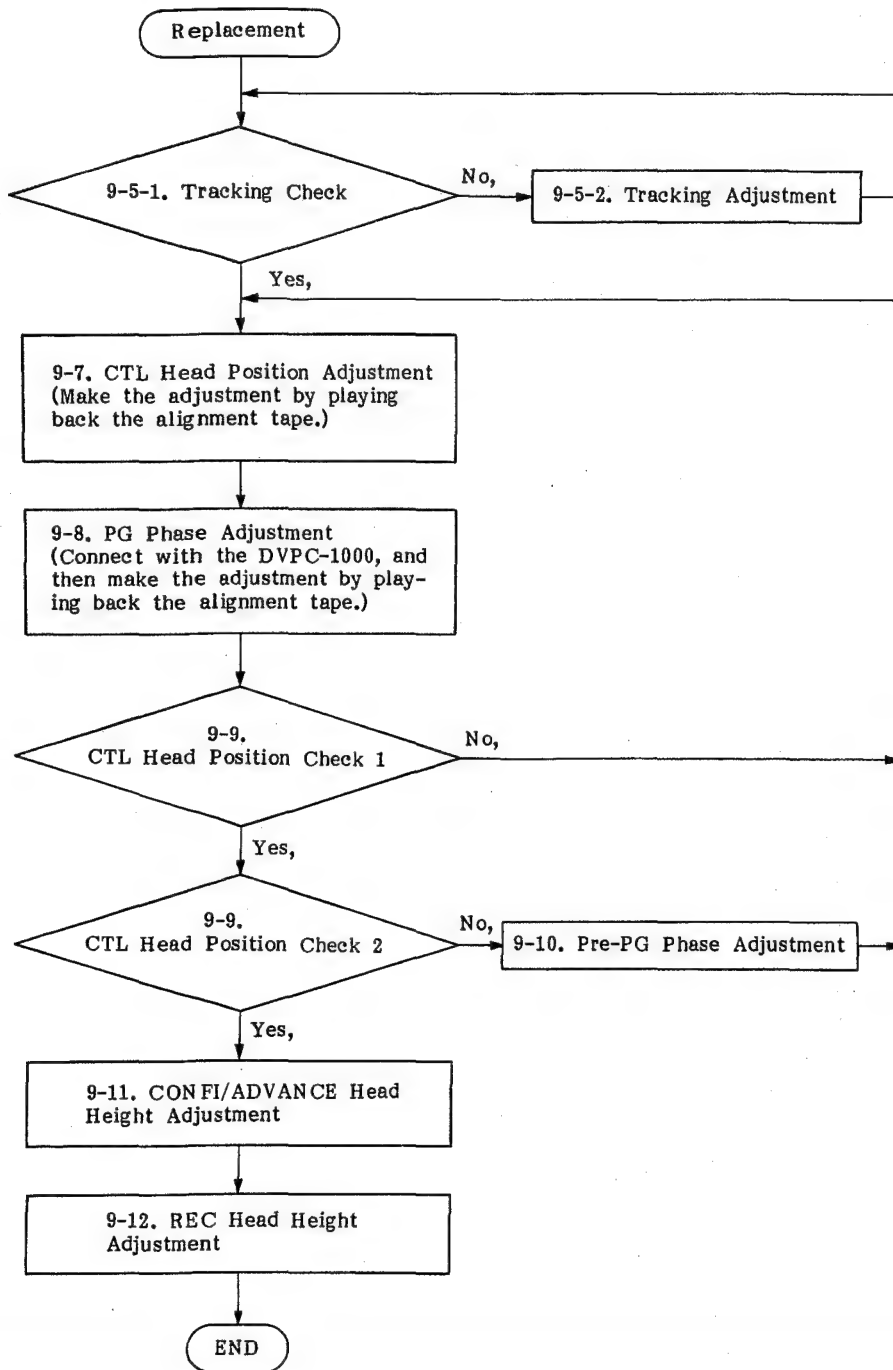

Fig. 6-5-2 Full-erase Head Adjustment

6-1-2. Adjustment Made after Replacement of the Scanner Assembly

Perform the following adjustments when the scanner assembly has been replaced.



6. PARTS REPLACEMENT AND ADJUSTMENT

6-2. DRUM ASSEMBLY

Background Knowledge

Use the following tools for replacement.

- Torque Driver 26kg-cm: J-6252-530-A
- Torque Driver Bit: J-6251-090-A

6-2-1. Replacement of the Drum Assembly

Disassembly

1. Remove the band that fixes the harness.
2. Disconnect the three connectors, CN742, CN743, and CN744, from the RF-15 board. (Fig. 6-6)
3. Unscrew the two screws and remove the drum cover.
4. Rotate the scanner so that the marking on the shaft ground holder matches the hole of the upper drum.
Note: The above procedure is only for finding the cap screw. Make sure to verify visually that there is a cap screw under the hole.
5. Loosen the screw that holds the drum assembly on the drum slant table by using a hexagon wrench. (Fig. 6-7)
Loosen the other two screws in a similar manner by performing steps 4 and 5.
Note: None of these three screws can be removed.
6. Lift up the drum assembly, as shown in the figure, and then disconnect the four connectors. (Fig. 6-8)
Note: Make sure to remove the connectors alternately from the ends.

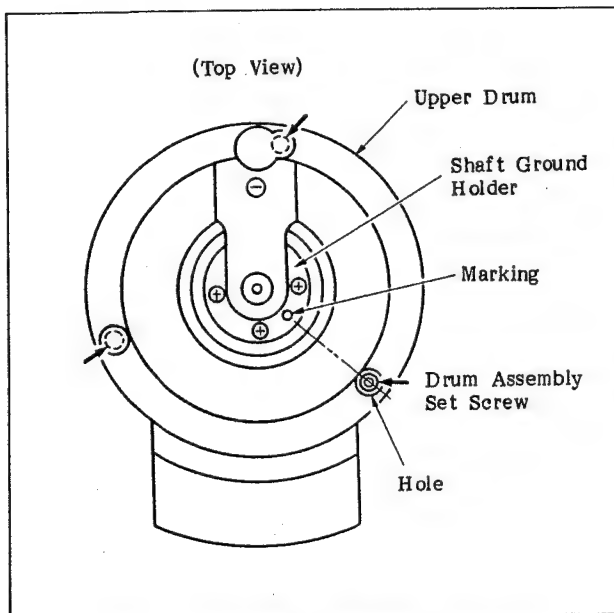

Fig. 6-7 Adjusting the Scanner Position

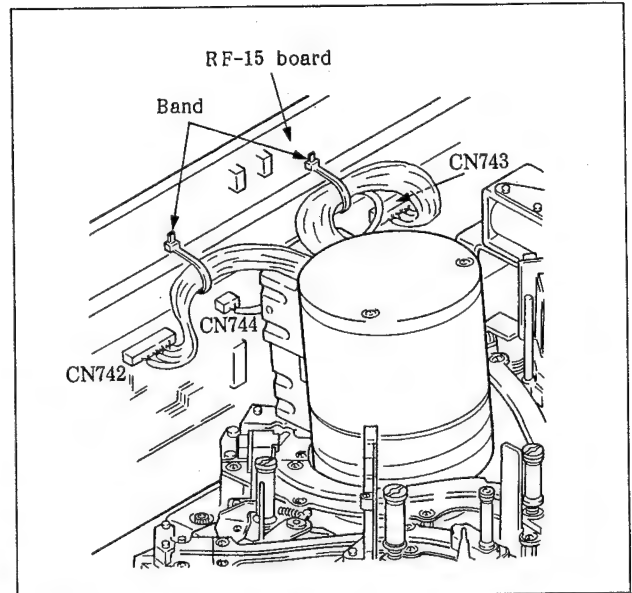

Fig. 6-6 Removing the Band and Disconnecting the Connectors

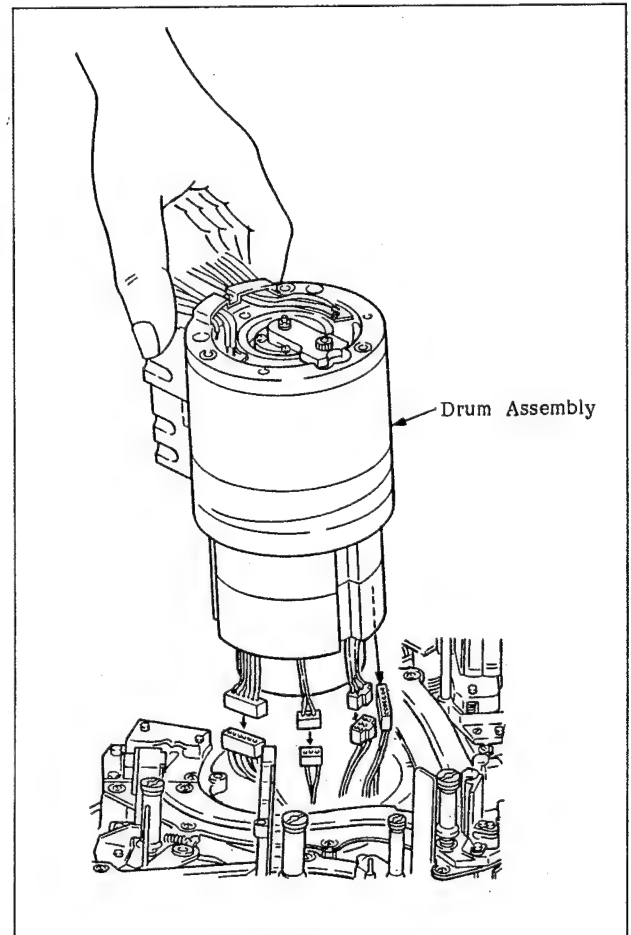

Fig. 6-8 Disassembling the Drum Assembly

Assembling

7. Holding replacement drum in one hand, insert the four connectors, CN1, CN2, CN3, and PRT, into their specified positions. (Fig. 6-8)

Note: Be careful not to touch the rotary head.

8. Place the drum so that the reference pin of the drum slant table matches the guide hole of the drum. (Fig. 6-9)
9. Rotate the scanner so that the marking of the shaft ground holder matches the hole of the upper drum. (Fig. 6-7)
10. Tighten the three screws to fasten the drum assembly. (Fig. 6-7)

Note: Tighten the three screws with a torque of 12kg-cm.

11. Fit the drum cover on the upper drum and fasten it with the two screws (+B3x8).
12. Insert the three connectors, CN742, CN743, and CN744, into their specified positions on the RF-15 board. (Fig. 6-6)
13. Return the harness removed in step 1 to its original position and fasten it.

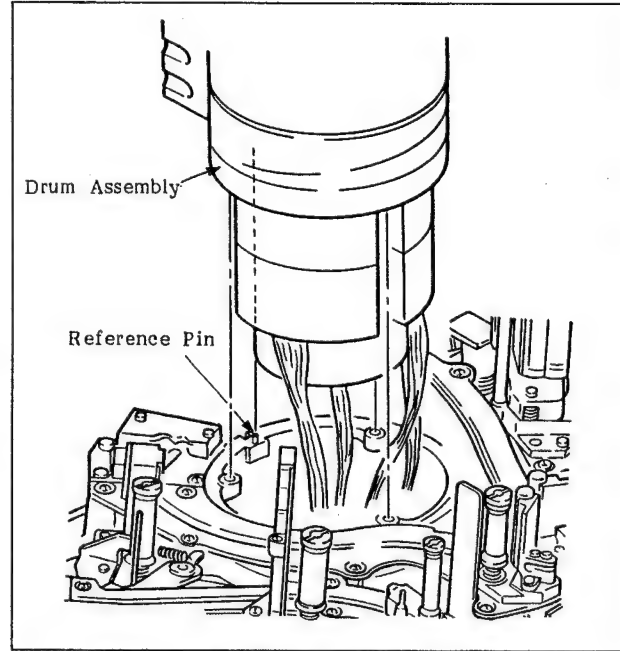
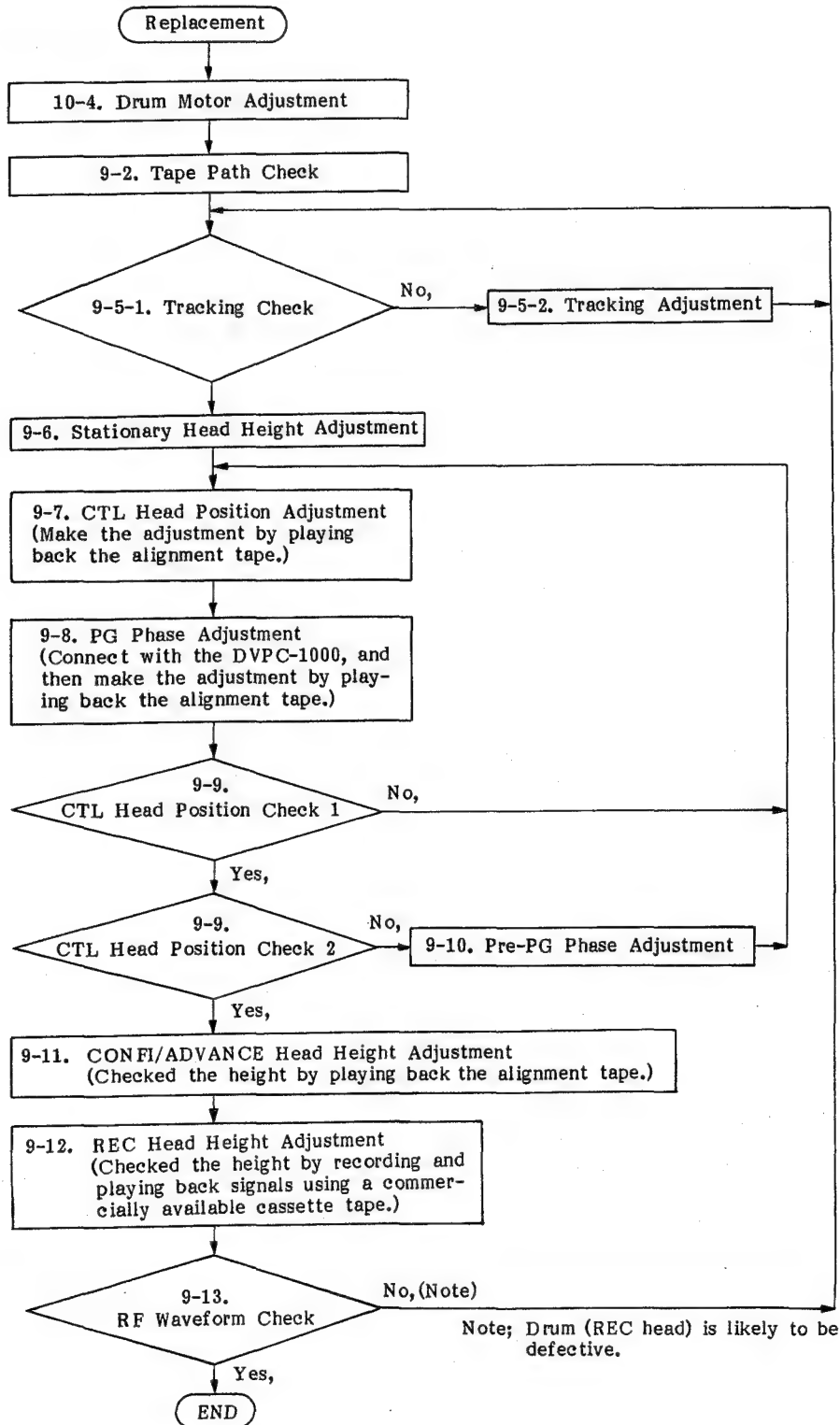

Fig. 6-9 Mounting the Drum Assembly

6-2-2. Adjustment Made After the Replacement of the Drum Assembly

Perform the following procedure after the drum assembly has been replaced.



6-3. REPLACEMENT OF THE SHAFT GROUND BUSHING

Background Knowledge

No other adjustment is necessary after the replacement of this part.

1. Unscrew the two screws and remove the drum cover.
2. Unscrew the screw and remove the shaft ground support.

Note: If the round contact of the shaft ground support is dirty, wipe it off; otherwise, do not touch it.

3. Remove the shaft ground bushing from the shaft ground support and replace it with a new one.

Note: Do not touch the flat contact of the shaft ground bushing because a special solution has been applied on it.

4. Check that the contact portion contacts properly. Then, fix the shaft ground support on the stator holder of the upper drum with a screw (C2.6x6).
5. Fix the drum cover with two screws (+B3x8).

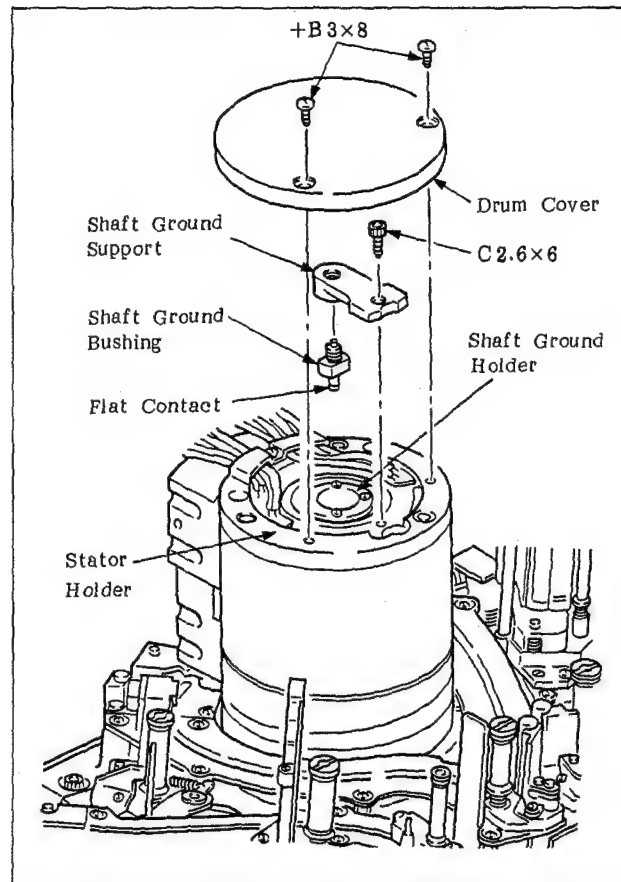

Fig. 6-10 Replacing the Shaft Ground Bushing



6-4. REPLACEMENT OF THE CASSETTE COMPARTMENT

Background Knowledge

A. Follow the procedure below to replace the cassette compartment.

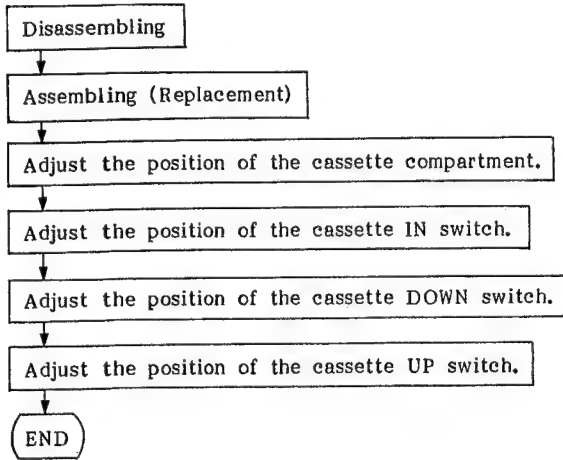

B. Be sure to check the mounting position of the cassette compartment and adjust it if necessary when you have removed the cassette compartment to replace a component of the cassette compartment or the reel table.

C. Prepare the following tools for adjustment of the cassette compartment position.

. Dummy cassette (for setting the IN SWITCH OFF; JB-5217):

J-6252-170-A

. Dummy cassette (for setting the IN SWITCH ON; JB-5218):

J-6259-180-A

. Thickness gauge:

J-6044-670-A

Disassembling

1. Remove the top plate, right and left side plates, control panel, escutcheon, escutcheon reinforcing plate, and SE-47 board cover in that order.
2. Unscrew the six screws that hold the cassette compartment.
3. Disconnect the connector CN310 from the CS-21 board.
4. Remove the cassette compartment by lifting it up.

Note: Be careful not to damage the flexible card wire (4P).

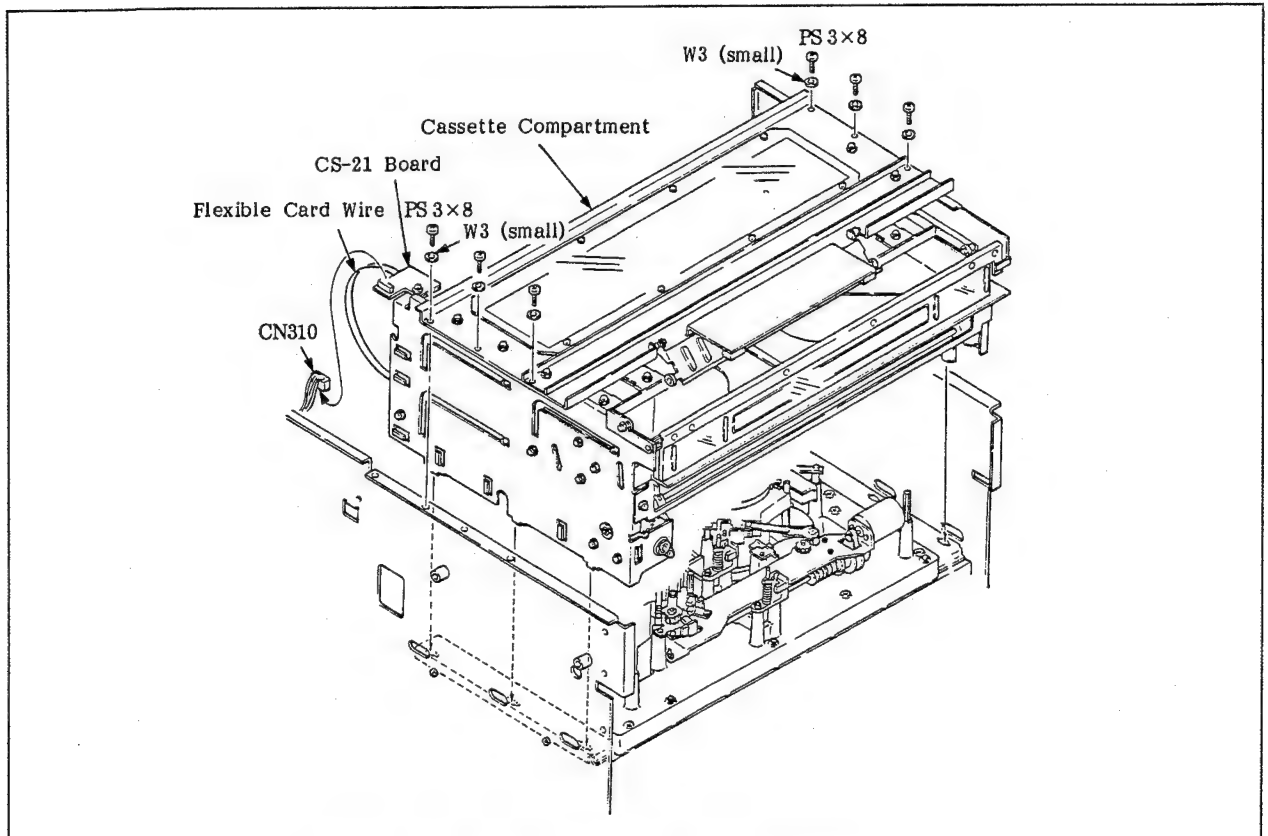

Fig. 6-11 Replacement of the Cassette Compartment

Assembling

1. Pull the connectors CN311 and CN312 that are connected with the CS-21 and CC-29 boards respectively toward you. Then push the flexible card wire straight into the connectors. After that, insert the connectors into the prescribed position. (Fig. 6-12)

Note: Check that the harness is set straight when viewed from the top.

2. Insert the right and left side plates' projections (three places each) of the cassette compartment into the holes of the right and left cassette compartment position adjustment boards.

Then tighten them securely with six screws (PS3 x 8). (Fig. 6-13)

Note 1: Be careful not to damage the flexible card wire (4P).

Note 2: There are the covered portion and the conductive portion. Properly connect the flexible card wire (4P), as shown in Fig. 6-12.

3. Connect the connector CN310 with the CS-21 board. Then mount the SE-47 board cover.

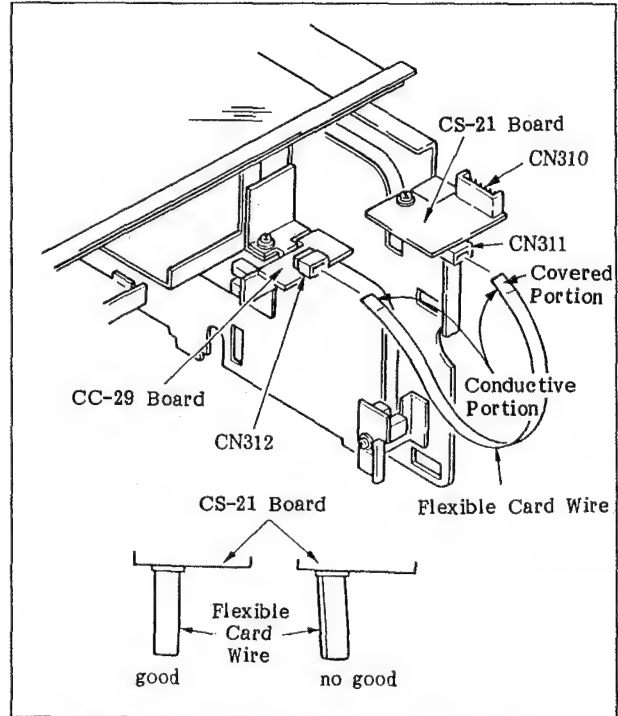

Fig. 6-12 Connecting the Flexible Card Wire

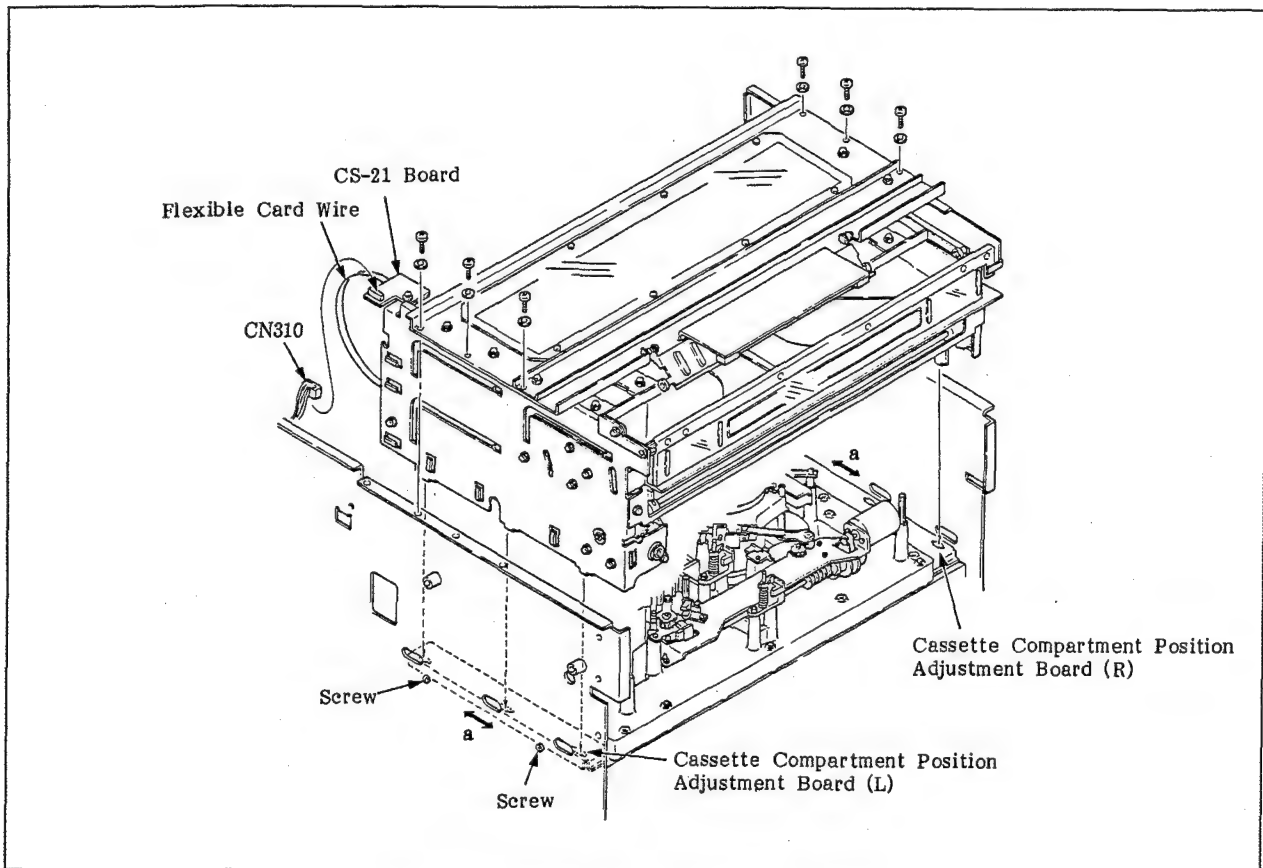

Fig. 6-13 Assembling the Cassette Compartment

Checking the Position

4. Insert the dummy cassette (IN SWITCH OFF type; JB-5217) into the cassette compartment.

Note: Check that the reel motor is at the M cassette position.

5. Turn the power on.
6. Press the **TEST**, **F3** (CHECKER), **F1** (CONTINUE), **F3** (c), **4**, **SET**, **F6** (F), **1**, **SET** keys on the control panel in that order to set the machine in the mechanical check mode.
7. Move the cassette down by pressing the **<** key on the keyboard.
8. Check that the clearance between the bent portion of the cassette compartment and the end face of the dummy cassette meets the required specification. If it does not, adjust it by following the procedure from step 9 on.

Spec.: The 0.5mm thickness gauge goes through.

The 0.8mm thickness gauge does not go through.

Adjusting the Position

9. Loosen the four screws (two for each side) that hold the right and left cassette compartment position adjustment boards, shown in Figure 6-13, by two or three turns so that it can be slid into the direction of arrow a.
10. Loosen the six screws that hold the cassette compartment by one to two turns.
11. Adjust the position of the cassette compartment by sliding it into the direction of arrow b so that the clearance between the bent portion of the cassette compartment and the end face of the dummy cassette meets the required specification shown in step 8. Then, tighten the six screws that were loosened in step 10. (Fig. 6-14)
12. Tighten the four screws that were loosened in step 9 to fasten the right and left cassette compartment adjustment plates.
13. Move the dummy cassette up by pressing the **>** key or the **<** and **>** keys on the keyboard, and then take out the dummy cassette.

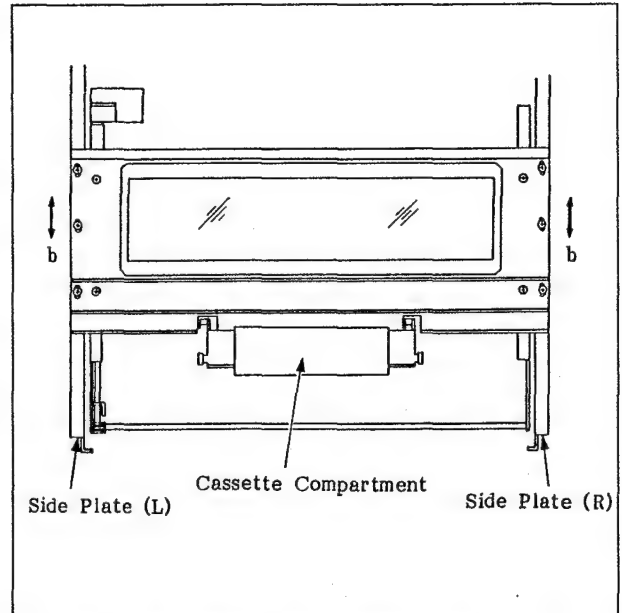

Fig. 6-14 Adjusting the Position of the Cassette Compartment 1

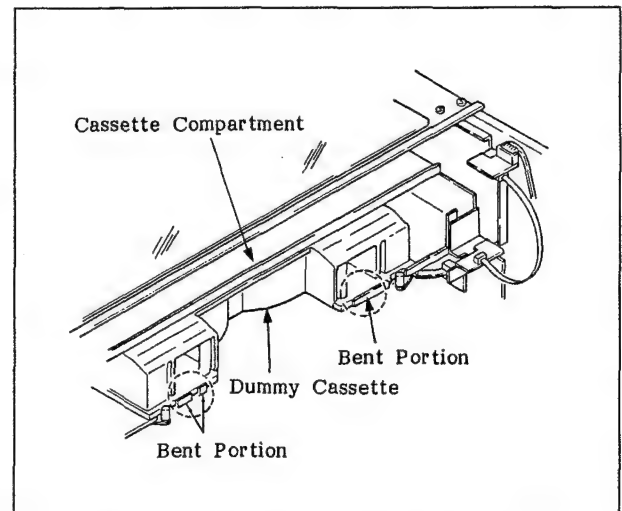
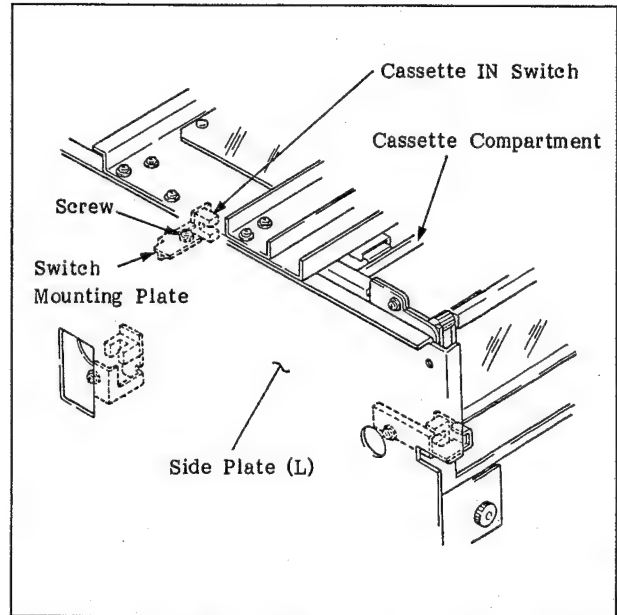
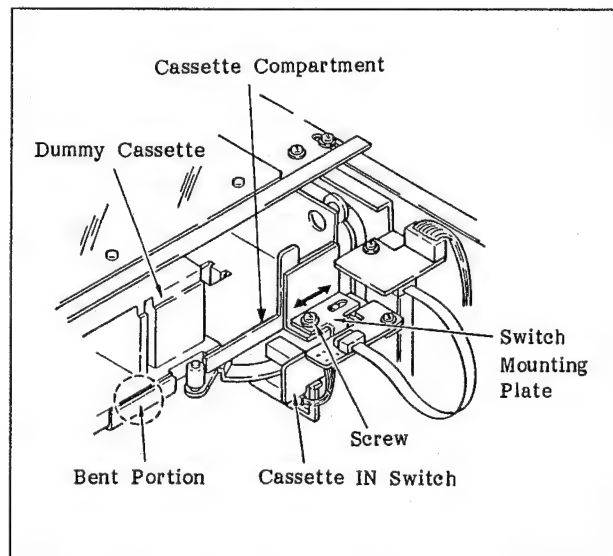

Fig. 6-15 Adjusting the Position of the Cassette Compartment 2

Adjusting the Position of the Cassette IN Switch

14. Press the **TEST**, **F3**(CHECKER), **F1**(CONTINUE), **F3** (C), **4**, **SET**, **F6** (F), **1**, **SET** keys on the control panel in that order to set the machine in the mechanical check mode.
15. Insert the dummy cassette (JB-5218), which is used for setting the IN SWITCH ON, into the cassette compartment. Confirm that the leftmost bit on the display of the control panel changes from 1 to 0. If it does not change, perform the following procedure for adjustment.
 - a. Press the **<** key on the control panel to move the dummy cassette and stop just before it moves straight down.
 - b. Loosen the attaching screw of the switch mounting plate by a half or one turn. Then, adjust the position of the switch mounting plate by sliding it in the direction of the arrow as shown in Figure 6-17 so that the leftmost bit on the display changes from 1 to 0. Check that the end face of the dummy cassette touches the bent portion of the cassette compartment at this time.
 - c. Press the **>** key on the control panel to move the cassette up.
16. Insert the dummy cassette (JB-5217), which is used for setting the IN SWITCH OFF, into the cassette compartment. Confirm that the leftmost bit, which is now set 1, on the display does not change at this time. If it changes, perform the following procedures for adjustment.
 - a. Press the **<** key on the control panel to move the dummy cassette and stop just before it moves straight down.
 - b. Loosen the attaching screw of the switch mounting plate by a half or one turn. Then, adjust the position of the switch mounting plate by sliding it in the direction of the arrow shown in Figure 6-17 so that the leftmost bit on the display remains 1. Check that the end face of the dummy cassette touches the bent portion of the cassette compartment at this time.
 - c. Press the **>** key on the control panel to move the cassette up.
17. Repeat steps 15 and 16 until both requirements are met.
18. Apply glue to the screw that holds the switch mounting plate after completion of adjustment.

**Fig. 6-16 Cassette IN Switch****Fig. 6-17 Adjusting the Position of the Cassette IN Switch**

Adjusting the Position of the Cassette DOWN Switch

19. Press the **TEST**, **F3**(CHECKER), **F1**(CONTINUE), **F3** (C), **4**, **SET**, **F5** (E), **8**, **SET** keys on the control panel in that order to set the machine in the data check mode.
20. Insert the D1-M size cassette in the cassette compartment and move the cassette down. Confirm that the fourth bit from the left on the display changes from 1 to 0 at this time.
21. If portion A in Figure 6-18 does not meet the required specification shown in Figure 6-19, loosen the attaching screw of the down sensor mounting plate by a half or one turn and then adjust the position of the sensor mounting plate by sliding it into the direction of the arrow by about 0.5 mm.
22. Move the cassette up and insert the cassette in the cassette compartment again. Then, confirm again that portion A in Figure 6-18 meets the required specification shown in Figure 6-19. If it does not, repeat steps 21 and 22 until the required specification is met.
23. Remove the cassette by pressing the EJECT button.
24. Apply glue to the screw that holds the switch mounting plate.

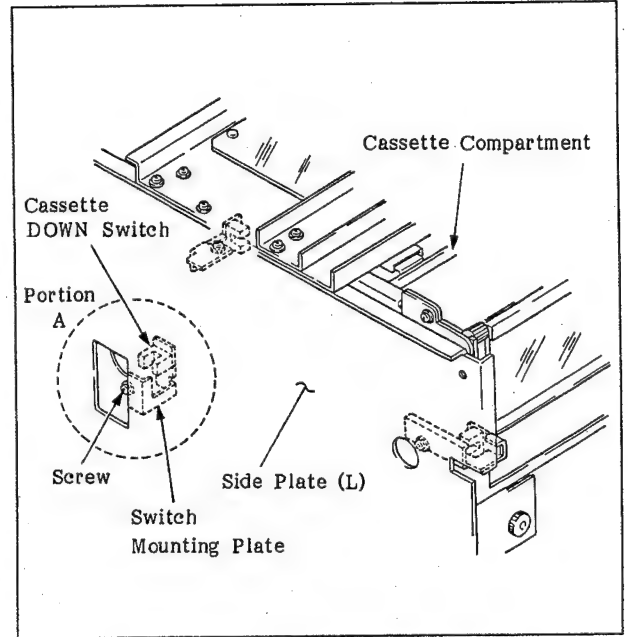

Fig. 6-18 Cassette DOWN Switch

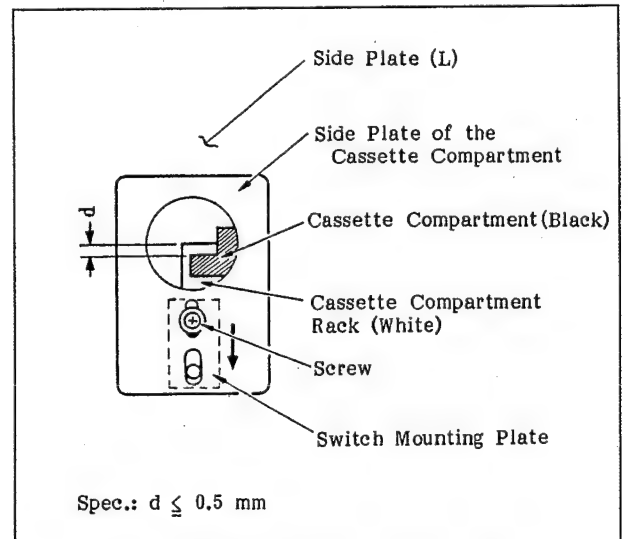

Fig. 6-19 Adjusting the Position of the Cassette DOWN Switch

6 PARTS REPLACEMENT AND ADJUSTMENT

Adjusting the Position of the Cassette UP Switch

25. Press the **TEST**, **F3**(CHECKER), **F1**(CONTINUE), **F3** (c), **4**, **SET**, **F5** (E), **8**, **SET** keys on the control panel in that order to set the machine in the data check mode.
26. Insert the D1-L size cassette in the cassette compartment and move the cassette down. Then, move it up by pressing the EJECT button. Confirm that the third bit from the left on the display changes from 1 to 0 at this time.
27. Confirm that there is no play in either portion a or portion b of the compartment shown in Figure 6-20. If there are plays in both portions a and b, loosen the screw that holds the switch mounting plate by a half or one turn, and then slide the switch mounting plate into the direction of the arrow shown in Figure 6-21 by about 0.5 mm. Repeat steps 26 and 27 until the play of the cassette compartment is eliminated.
28. Remove the cassette by pressing the EJECT button.
29. Apply glue to the screw that holds the switch mounting plate.
30. To assemble the panels, perform the steps of disassembly in reverse order.

Note 1: To mount the control panel, insert the escutcheon harness along between the side plate of the body and the side plate of the cassette compartment. Otherwise, the harness might be caught between the front plate of the cassette compartment and the control panel.

Note 2: To mount the escutcheon, tighten the set screws while pushing the escutcheon downward.

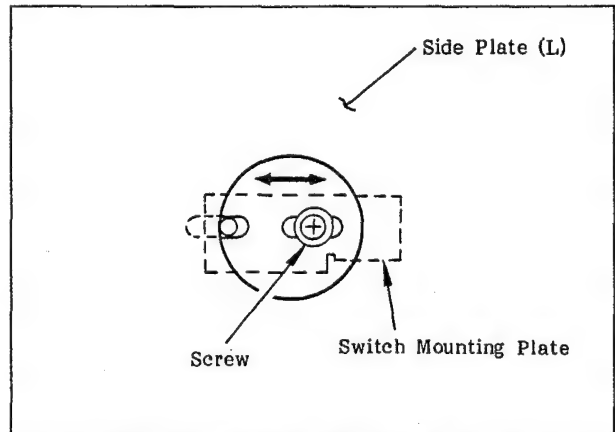

Fig. 6-21 Adjusting the Position of the Cassette UP Switch

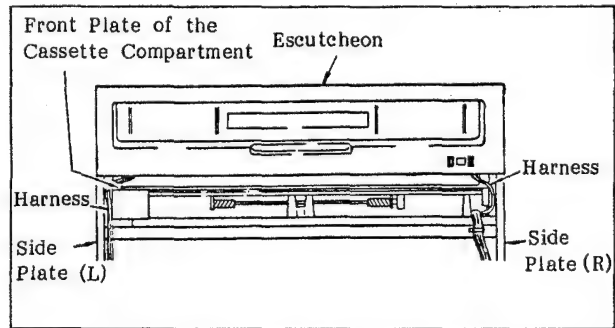

Fig. 6-22 Leading of the Harness

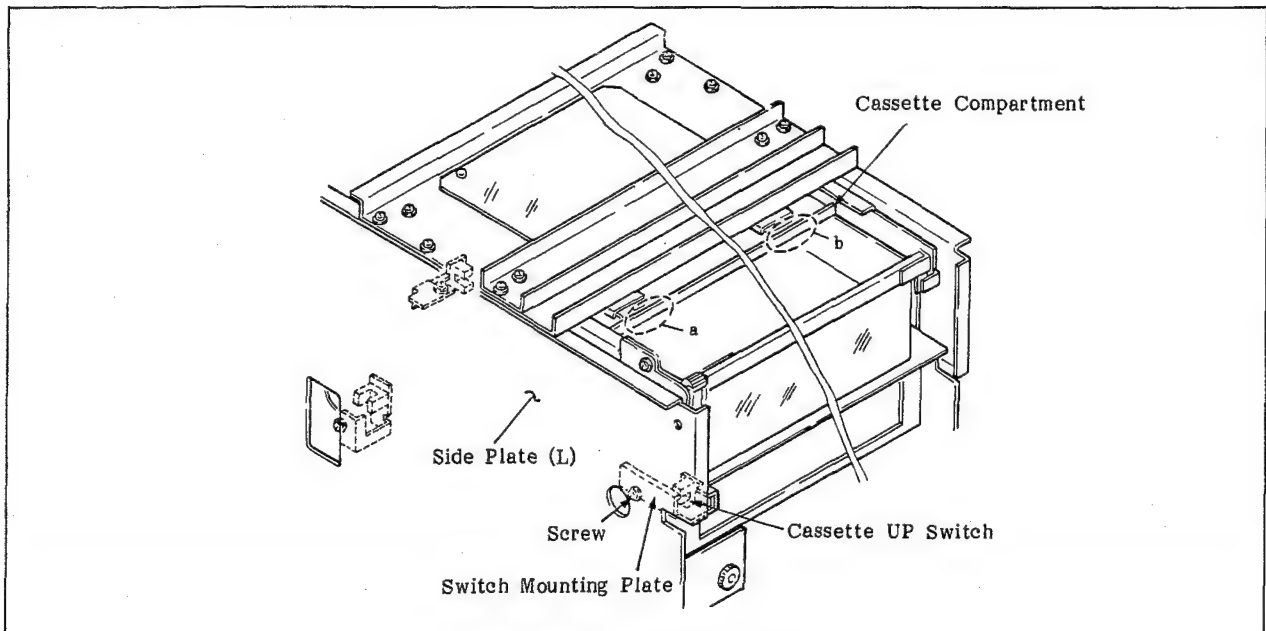

Fig. 6-20 Cassette UP Switch

6-5. REPLACEMENT OF COMPONENTS OF THE CASSETTE COMPARTMENT

Background knowledge

- A. Components of the cassette compartment can be easily replaced. Refer to the following drawing for replacement. The procedure for adjustment required after replacement will be described in the following sections.
- B. When the cassette compartment has been removed for replacement, check the position of the cassette compartment by referring to the background knowledge by section 6-4 and adjust it if necessary.

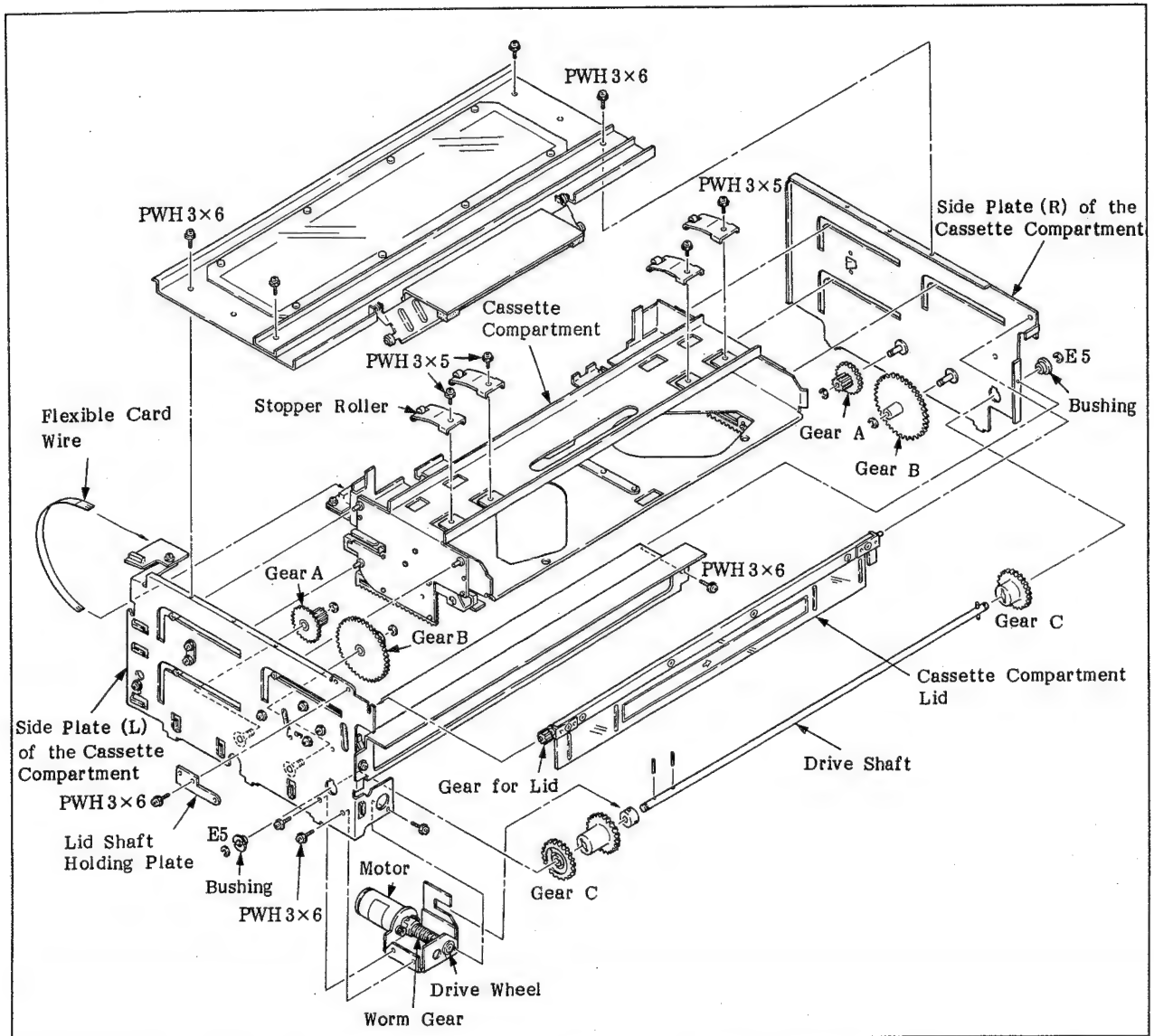

Fig. 6-23 Replacement of Components of the Cassette Compartment

6-5-1. Replacement of the Motor

Background Knowledge

It is necessary to adjust the clearance between the worm gear and the coupling in the similar manner as described in this section also in the case the worm gear, worm gear shaft, or coupling has been replaced.

1. Unscrew the six screws that hold the cassette compartment and remove it.
2. Replace the motor with a new one by referring to Figure 6-23.
3. Insert a 0.7 mm thickness gauge in between the coupling and the worm gear as shown in Figure 6-24. Then, tighten the two set screws that hold the coupling while the worm gear and the worm gear shaft are being pressed in the direction of the arrow shown in the figure.
4. Mount the cassette compartment on the machine by referring to section 6-4 and adjust the position.
5. Tighten the two set screws while the guide plate is being pressed in the direction of the arrow shown in Figure 6-25. Make sure that the guide plate is mounted parallel to the motor mounting plate at this time.

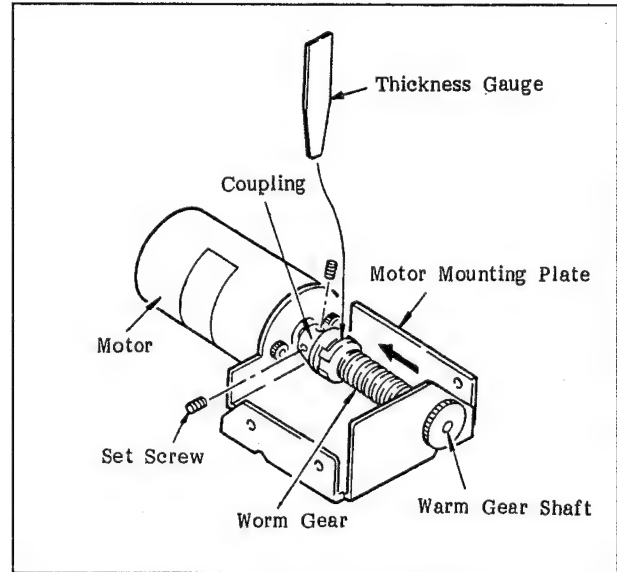

Fig. 6-24 Adjusting the Coupling

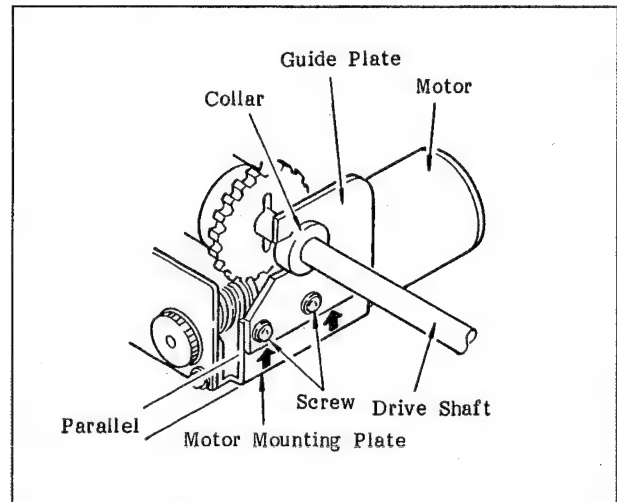

Fig. 6-25 Adjusting the Position of the Guide Plate

6-5-2. Replacement of Gear A

Background Knowledge

A gear A is used in each of the right and left sides. It is necessary to adjust the phase of these two gears and the meshing of the rack and the pinion.

1. Unscrew the six screws that hold the cassette compartment and remove it.
2. Turn the drive wheel by a hand so that the slot of gear A shown in Figure 6-27 can be seen through the hole of the side plate of the cassette compartment shown in Figure 6-26.
3. Place the cassette compartment so that the side plate on which gear A to be replaced is mounted is facing up. Then, unscrew the three screws (PWH3 x 6) that hold the side plate and remove the E ring (E5) that is attached on the drive shaft. To replace the gear on the left side, unscrew the two screws (PWH3 x 6) that hold the guide plate and remove the side plate.
4. Remove the E ring that holds gear A, and then replace gear A with a new one.
5. Screw a screw (PWH2.6 x 10) into the hole of the side plate shown in Figure 6-27 and pass the screw through the slot of gear A.
6. Screw a screw (PWH2.6 x 10) into the hole of the side plate on the other side and pass the screw through the slot of gear A in a similar manner.
7. Mount the removed side plates in their original position.

Note: Confirm that the dowels on the top plate and the front plate are inserted into the holes.

8. Remove the two screws that were screwed in steps 5 and 6.
9. Mount the cassette compartment on the machine by referring to section 6-4.

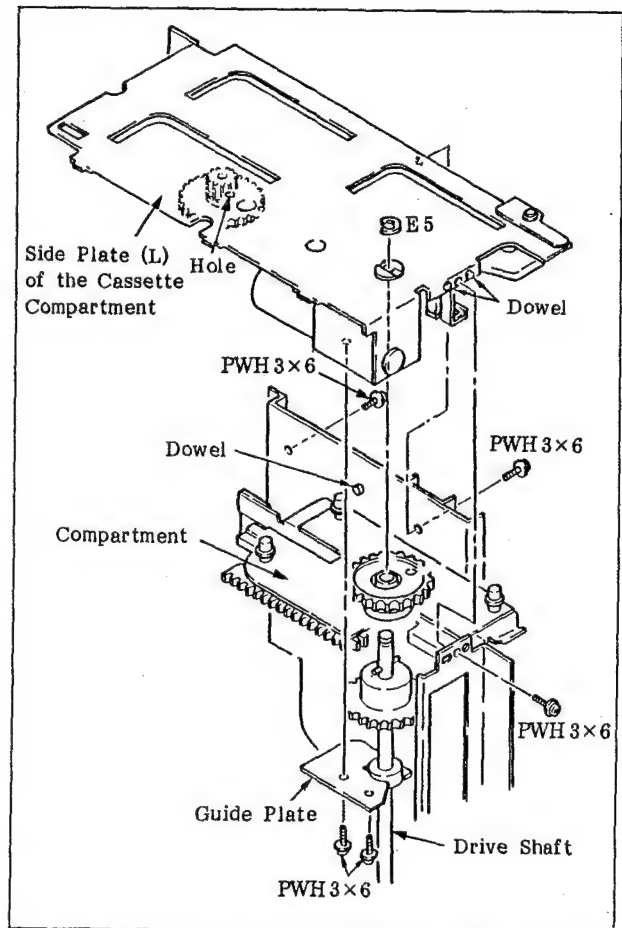

Fig. 6-26 Replacement of Gear A (left side)

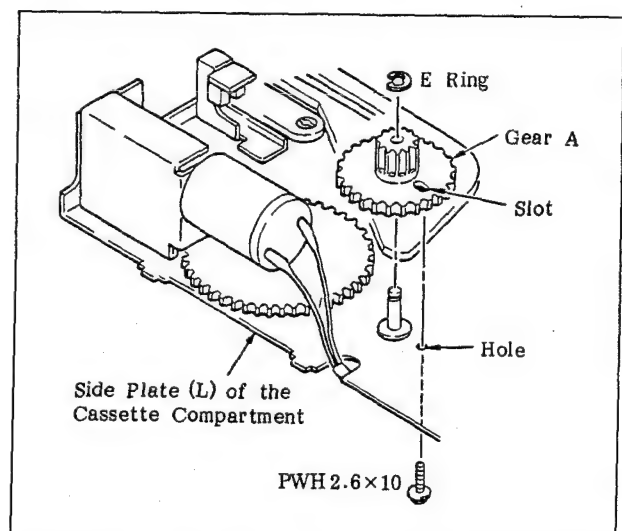

Fig. 6-27 Adjusting the Phase



6-5-3. Replacement of Gear C

1. Unscrew the six screws that hold the cassette compartment and remove it.
2. Place the cassette compartment so that the side plate on which gear C to be replaced is mounted is facing up. Then, unscrew the three screws (PWH3 x 6) that hold the side plate and remove the E ring (E5) that is attached on the drive shaft. To replace the gear on the left side, unscrew the two screws (PWH3 x 6) that hold the guide plate and remove the side plate.
3. Replace gear C with a new one. Mount gear C so that the phase hole of the gear faces that of gear C on the other side.
4. Mount the removed side plates in their original position and fasten them it with screws.

Note: Confirm that the dowels on the top plate and the front plate are inserted into the holes.

5. Mount the cassette compartment on the machine by referring to section 6-4.

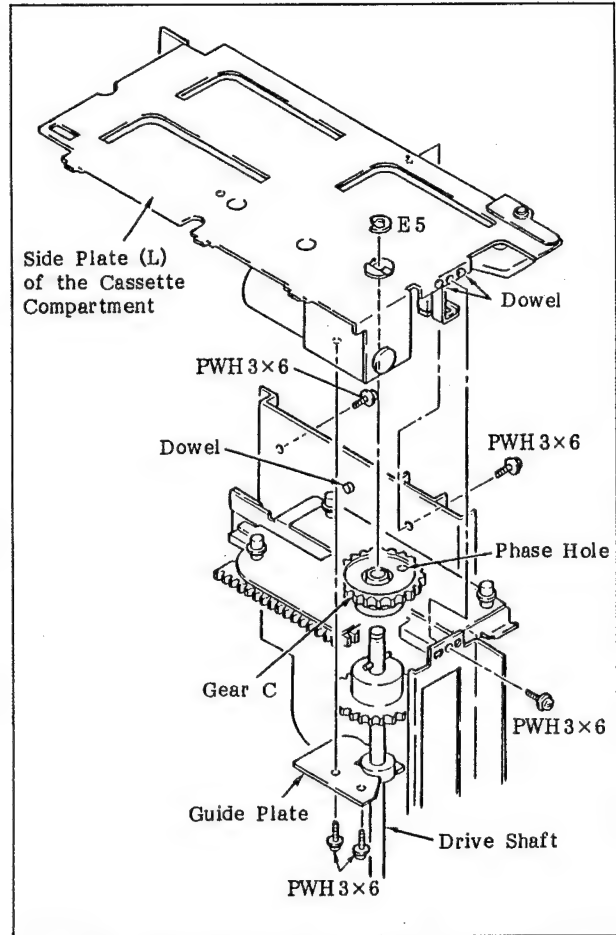

Fig. 6-28 Replacement of Gear C (left side)

6-5-4. Replacement of the Stopper Roller

Background Knowledge

Prepare the following cassette tapes for replacement.

- D1M size cassette
- D1L size cassette

1. Remove the eight nylon rivets to remove the cover.
2. Insert a following cassette in the cassette compartment according to the position of the stopper roller to be replaced until the cassette reaches the end.
To replace the stopper roller ① or ② :
D1M size cassette
To replace the stopper roller ③ or ④ :
D1L size cassette
3. Slide the cassette compartment by turning the drive wheel until the screw that holds the stopper roller is visible.
4. Replace the stopper roller with a new one by referring to Figure 6-29 and fasten the stopper roller with a screw (PWH3 x 5). Leave the screw loose enough to allow the stopper roller to be moved slightly.
5. Slide the stopper roller so that it touches the bank of the groove of the cassette as shown in Figure 6-30, and then fasten the stopper roller tightly.
6. Mount the cover and fasten it with eight nylon rivets.

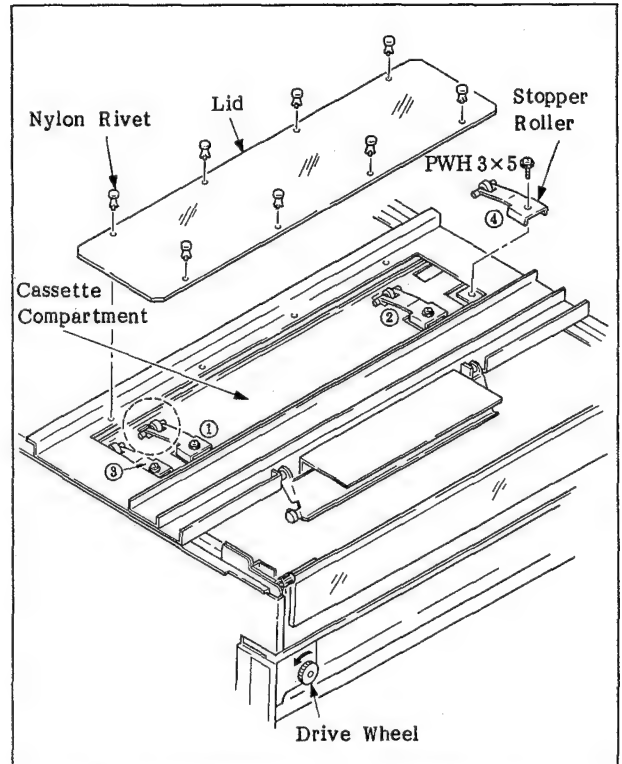

Fig. 6-29 Replacement of the Stopper Roller

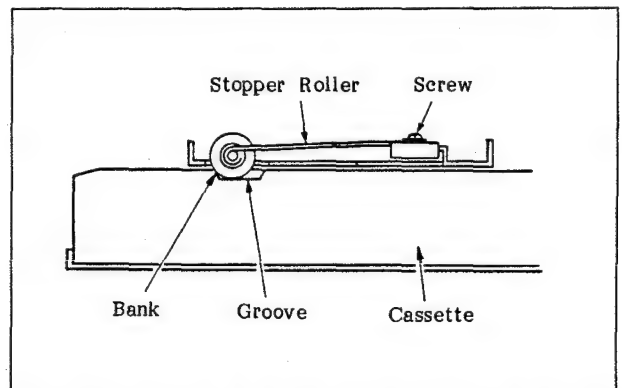

Fig. 6-30 Adjusting the Position of the Stopper Roller



6-5-5. Replacement of the Cassette Compartment Lid

Background Knowledge

It is necessary to adjust the phase of the gear to be described here in this section also when the lid swing arm or the lid gear has been replaced.

1. Unscrew the six screws that hold the cassette compartment and remove it.
2. Remove the cassette compartment lid by referring to Figure 6-23.
3. Replace the cassette compartment lid with a new one. Then, adjust the position of the lid swing arm so that the lid gear meshes at the third trough of the gear of the swing lid arm.
4. Fasten the lid shaft holding plate tightly in the prescribed position.
5. Mount the cassette compartment on the machine and adjust its position by referring to section 6-4.

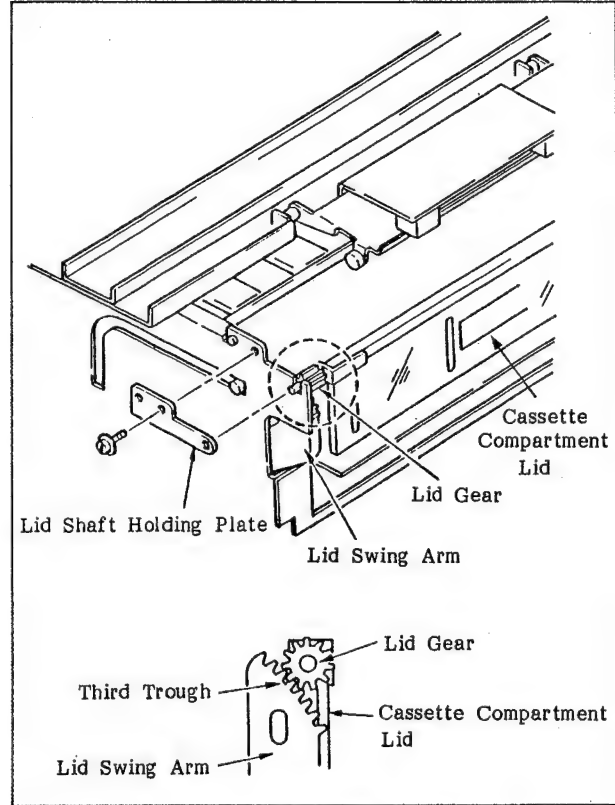

Fig. 6-31 Replacement of the Cassette Compartment Lid

6-6. REPLACEMENT OF THE REEL MOTOR

Background Knowledge

A. Replace and adjust according to the following procedures.

When replacing the T reel motor:

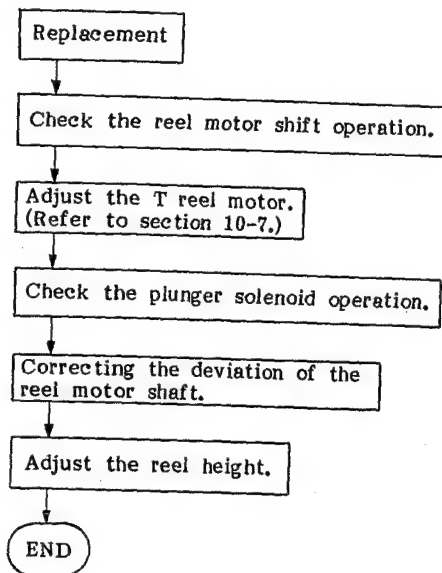

When replacing the S reel motor:

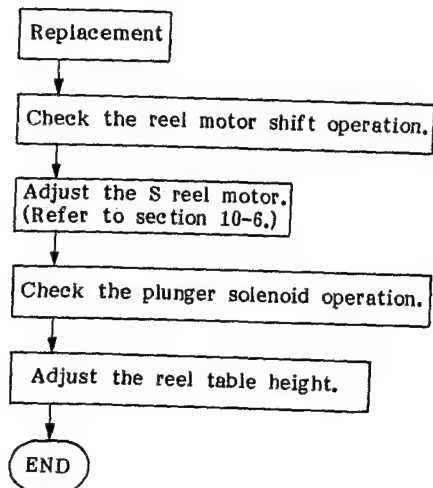

B. Use the following tools for making the adjustment.

Reel plate: J-6251-170-B

Reel table height adj. tool: J-6252-190-A

Reel table shaft adjustment tool: J-6252-400-A

C. The cassette compartment is removed when making the replacement. When attaching the cassette compartment again after completion of replacement and adjustment, confirm its position and make any necessary adjustment by referring to section 6-4.

Replacement

1. Unscrew the six screws that hold the cassette compartment and remove it.
2. Remove the receptacle cover of the CN-157 board and pull out the flexible card wire (26P).
3. Unscrew the two screws (C3 x 20) that hold the two guide shafts and remove the E ring (E2.3) that holds the crank arm (B), and then remove the motor frame.
4. Loosen the two set screws that hold the reel table and remove the reel table from the motor frame.
5. Disconnect the harness of the plunger solenoid from the reel motor.
6. Unscrew the four screws (PS3 x 6) and remove the reel motor.
7. Clean the reel motor mounting side of the motor frame.
8. Replace the motor and then reassemble by performing steps 2 through 6 in reverse order. Do not connect the crank arm (B) and the crank arm assembly at this time.
9. Move the motor frame by hand and check that the shift operation is smooth. If it does not move smoothly, loosen the two screws (C3x20) that hold each of the two guide shafts and make adjustments so that it moves smoothly.
10. Fasten the crank arm (B) and the crank arm assembly with the E ring (E2.3).

Check the reel motor shift operation

11. Turn on the power of the machine.
12. Press the **TEST**, **F3** (CHECKER), **F1** (CONTINUE), **F3** (C), **4** **SET**, **F6** (F), **0**, and **SET** keys on the control panel in that order to set the machine in the mechanical check mode of the reel shift.
13. Press the **<** and **□** keys on the control panel to shift the reel motor to the L cassette position. Then press the **□** and **>** keys on the control panel to shift the reel motor to the M cassette position. Repeat this operation several times and check that the shift operation is smooth. If it is not smooth, disconnect the crank arm (B) from the crank arm assembly and then repeat the procedure of step 9 above.

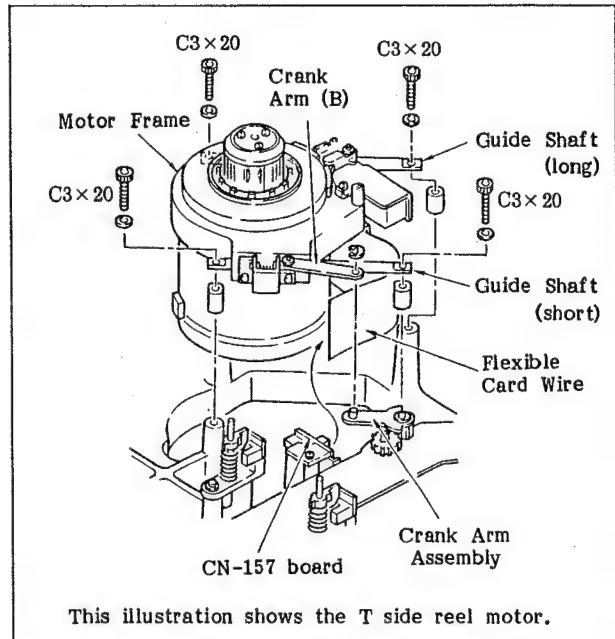

Fig. 6-32-1 Replacing the Reel Motor (1)

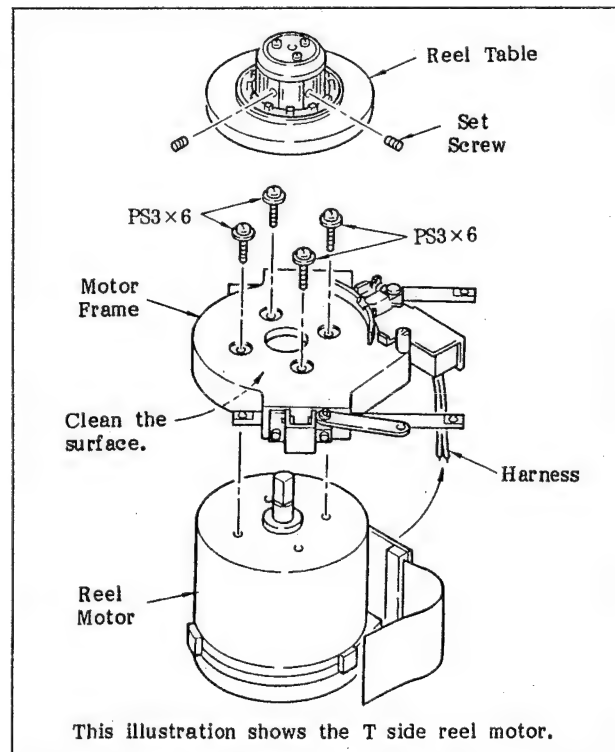

Fig. 6-32-2 Replacing the Reel Motor (2)

Adjusting the Reel Motor

(Adjustments made after the replacement of the T reel motor)

14. Refer to section 10-7.

(Adjustments made after the replacement of the S reel motor)

15. Refer to section 10-6.

Checking the Operation of the Plunger Solenoid

16. Turn on the power of the machine and then check suction of the S and T plungers. If the plungers do not have suction, check the joint portion of the harness and the reel motor.

Correcting the Deviation of the Reel Motor Shaft

Note: The adjustments in steps 17 through 21 are made only when the T reel motor is replaced.

17. Set the reel motor shift in the M cassette position.
18. Loosen the two screws that hold the reel table and remove the reel table. (Fig. 6-32-2)
19. Set the reel plate and the reel table shaft adjustment tool. (Fig. 6-33-1)
20. Turn the reel table shaft adjustment tool in the direction of arrow B and check the pointer of the dial gauge indicates the maximum value in the range of A, shown in Fig. 6-33-1, and the difference between the maximum value and the minimum value of the dial gauge is less than 120 to 220 μ m. If it is not, make the following adjustments. Remove the tool.
21. Remove the four screws (PS3x6). Select an appropriate one from the following spacers and insert it between the motor and the motor frame, and then tighten the screws. Perform steps 19 and 20 again.

Spacer

| Thickness (μ m) | Part Number |
|----------------------|--------------|
| 10 | 3-715-470-31 |
| 20 | 3-715-470-21 |
| 50 | 3-715-470-11 |
| 100 | 3-715-470-01 |

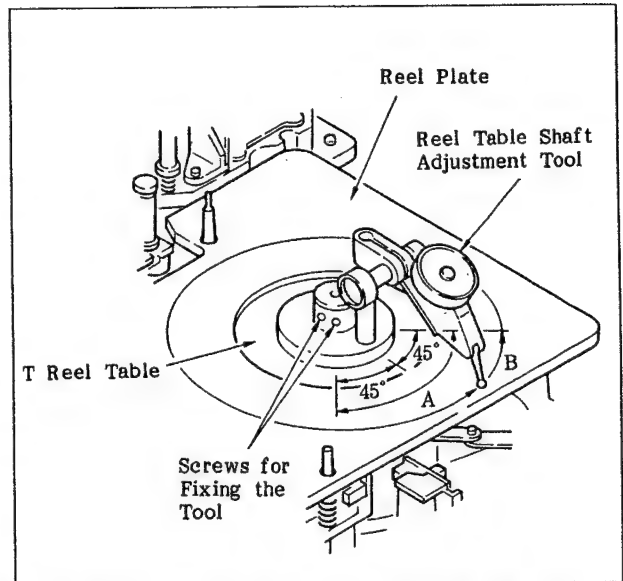

Fig. 6-33-1 Correcting the Deviation of the Reel Motor Shaft (1)

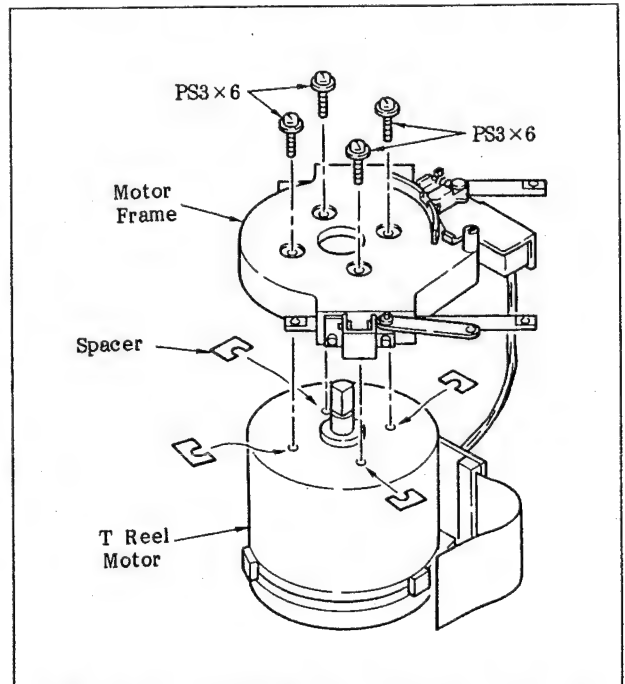

Fig. 6-33-2 Correcting the Deviation of the Reel Motor Shaft (2)

Adjusting the Height of the Reel Table

22. Shift the reel motor to the M cassette position.
23. Set the reel plate.
24. Loosen the two set screws (4x6) that hold the reel table.
25. Place the tool for adjusting the height of the reel table as shown in Fig. 6-33, adjust the height of the reel table by turning the set screw on the upper part of the reel table so that the reel seat becomes higher than the reel plate by 0.2mm or less.
26. Repeat step 25 to check the height at three places (at 120 degree intervals) on the reel table and adjust if necessary.
27. Fasten the reel table securely by tightening the two set screws (4x6).
28. Mount the cassette compartment by referring to section 6-4.

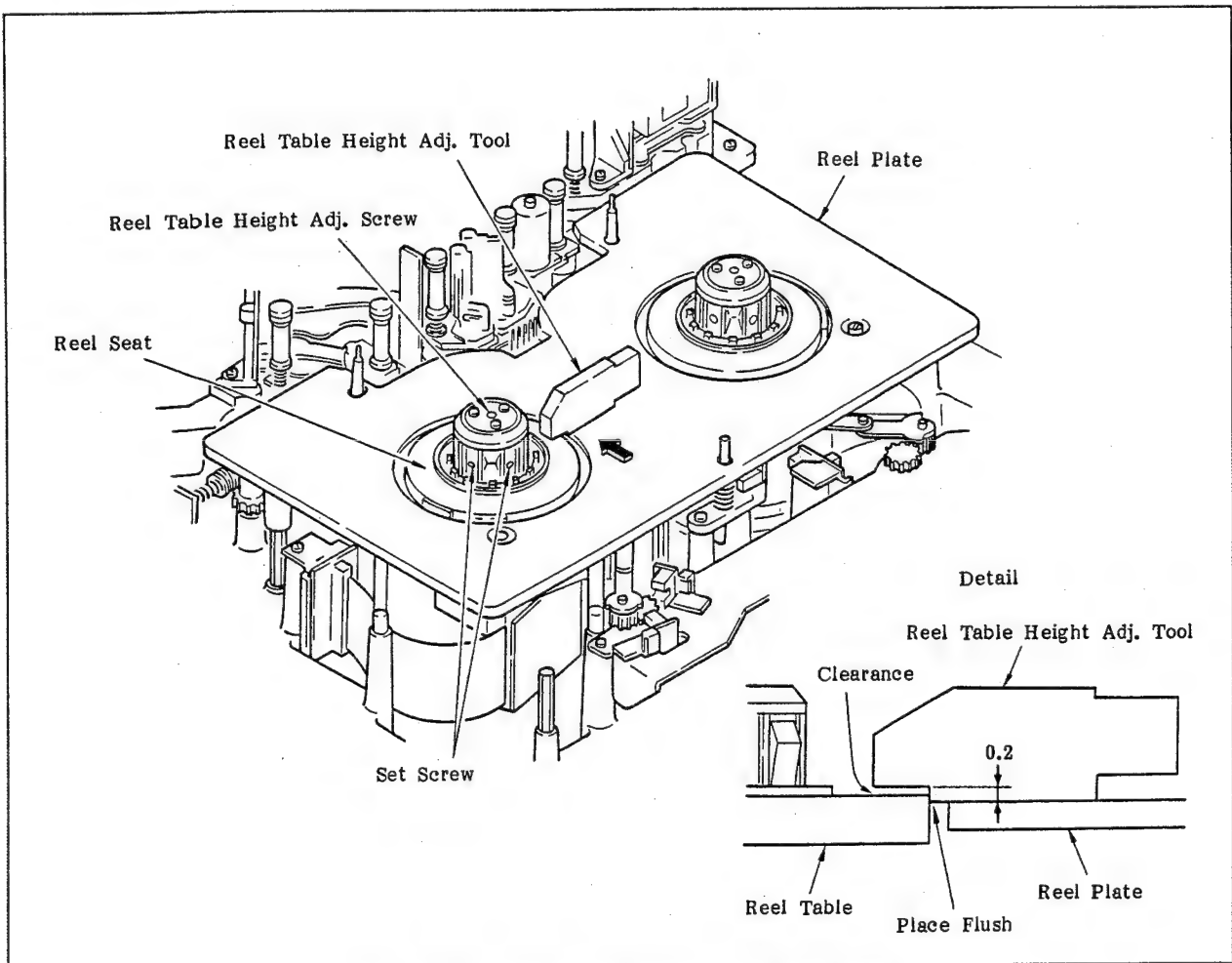

Fig. 6-33-3 Adjusting the Height of the Reel Table

6-7. REPLACING THE BRAKE ARM AND THE PLUNGER SOLENOID

Background knowledge

- A. It is recommended that the tension spring connected to the brake arm should be replaced whenever the brake arm is replaced, as it is often damaged during replacement of the brake arm.
- B. The plunger solenoid can also be replaced by referring to this procedure, but a brake torque adjustment must be made after replacement.

Replacement

1. Unscrew the six screws that hold the cassette compartment, and remove it.
2. Remove the brake arm assembly.
3. Remove the two screws (B2.6x4, K2.6x4 precision screw) and then remove the plunger solenoid and the return spring assembly.
4. Remove the tension spring and E ring (E2.3), and then remove the brake arm, compression spring and sleeve.
5. Replace the tension spring and the brake arm with new ones.
6. Fasten the plunger solenoid and the return spring assembly with the two screws (B2.6x4, K2.6x4 precision screw).
7. Mount the brake arm assembly on the motor frame and hold it with two screws (PSW2.6 x 5). Leave screw (B) loose enough so that the brake arm assembly can be moved easily around screw (A), as shown in Figure 6-35.

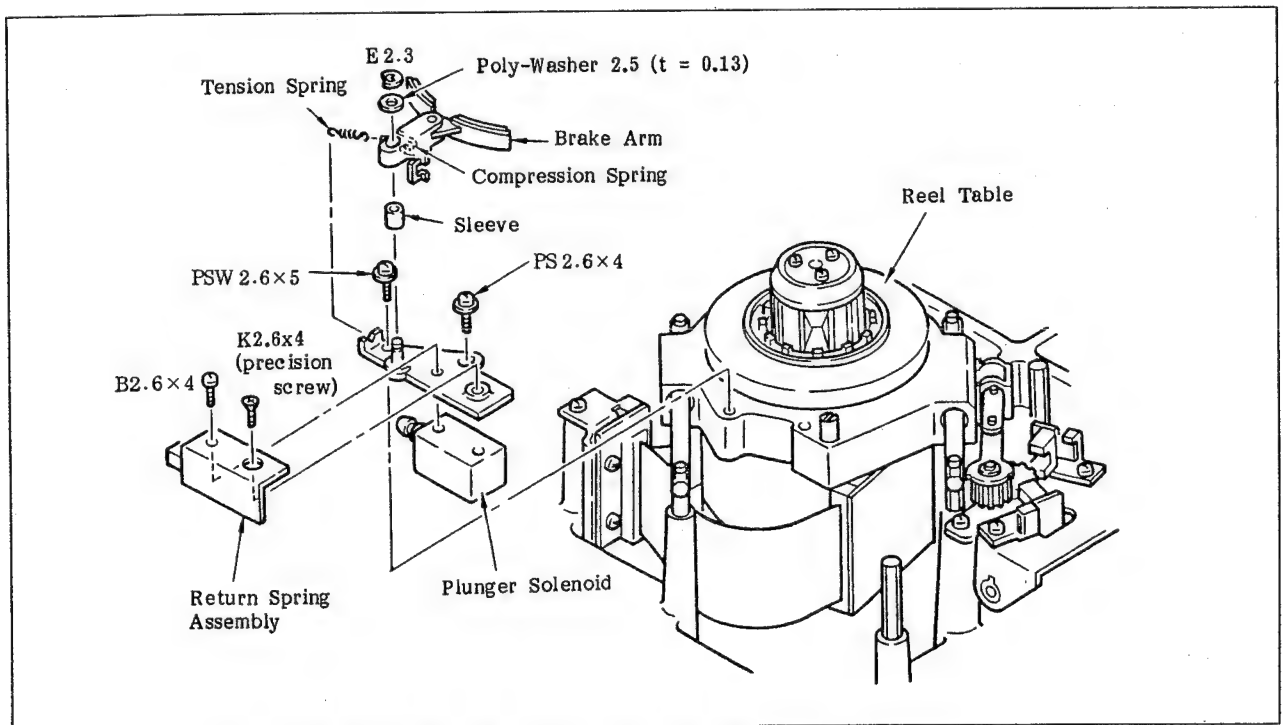

Fig. 6-23 Replacing the Brake Arm and the Plunger Solenoid



Adjusting the Brake Torque

8. Mount the brake arm assembly so that the one-millimeter diameter hole looks as if it were contact with the brake arm when viewed from the top, as shown in Figure 6-35, and then fasten it firmly with screw (B).
9. After replacement of the S brake arm, confirm that more than half of the hole is covered with the brake arm when the reel table is rotated clockwise (in the case of replacement of the T brake arm, when the reel table is rotated counterclockwise). If more than half of the hole is not covered, perform the following step.
10. Loosen screw (B) enough so that the brake arm assembly can be moved slightly in the direction of the arrow, as shown in the upper drawing of Figure 6-35, and then tighten screw (B). Perform step 9 again.
11. Tighten the two screws, (A) and (B), securely.
12. Rotate the reel table clockwise (in case of the T brake arm, rotate the reel table counterclockwise) so that more than half of the hole is covered with the brake arm. Confirm that the compression spring in the brake arm still has room to move when the brake arm is pushed in the direction of the arrow, as shown in the lower drawing of Figure 6-35. If the spring has no room to move, loosen screw (B) and slightly move the brake arm assembly in the opposite direction of the arrow shown in the upper drawing and then tighten screw (B). Then, perform step 9 again.
13. Mount the cassette compartment and adjust its position by referring to section 6-4.

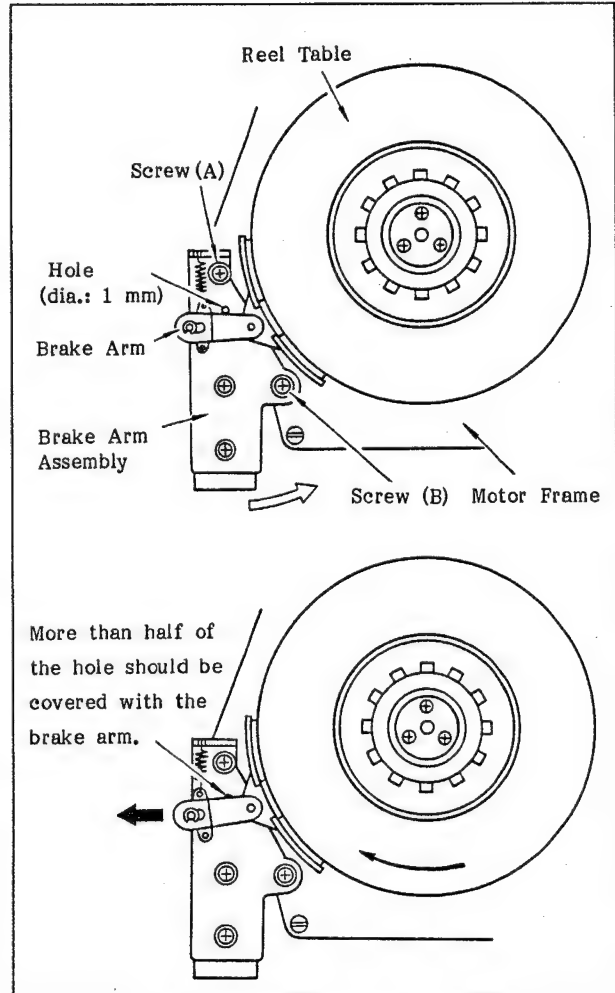

Fig. 6-35 Adjusting the Brake Torque

6-8. REPLACEMENT OF THE REEL MOTOR SHIFT COMPONENTS
COMPONENTS

Background Knowledge

- A. Refer to Figure 6-36 concerning the replacement of the reel motor shift components. They can be easily replaced. This section will describe the procedures for making the adjustments after replacement.
- B. Refer to section 6-4 for mounting the cassette compartment.

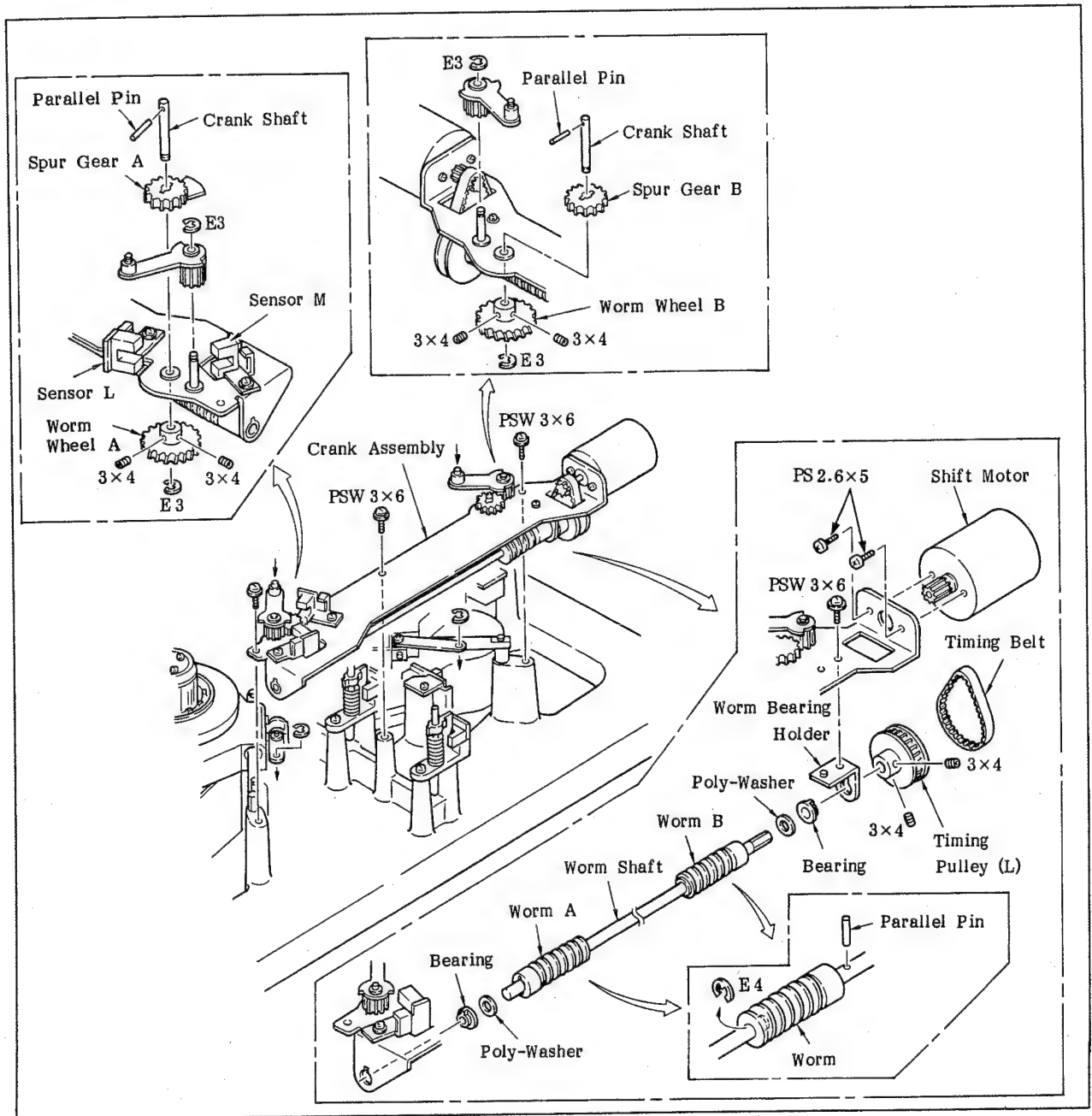

Fig. 6-36 Replacing the Reel Motor Shift Components

6-8-1. Replacement of the Timing Pulley

1. Unscrew the six screws that hold the cassette compartment and remove it.
2. Remove the timing belt.
3. Remove the stay shown in Figure 6-39.
4. Unscrew the two screws that hold the shift motor and remove it.
5. Loosen the two set screws (3 x 4) that hold the timing pulley and remove it.
6. Replace the timing pulley with a new one by inserting it so that the D cut surfaces of the worm shaft match the two tap holes.
7. Insert a 0.5 mm thickness gauge between the bearing and the timing pulley as shown in Figure 6-37, and fasten the timing pulley by securing with the two set screws (3 x 4) while pushing the timing pulley towards the bearing.
8. Replace the shift motor and fasten it with the two screws (PS2.6 x 5), and reinstall the stay that was removed in step 3.
9. Set the timing belt on the larger pulley first, and then set it on the smaller pulley, as shown in Figure 6-38.
10. Reinstall the cassette compartment by referring to section 6-4.

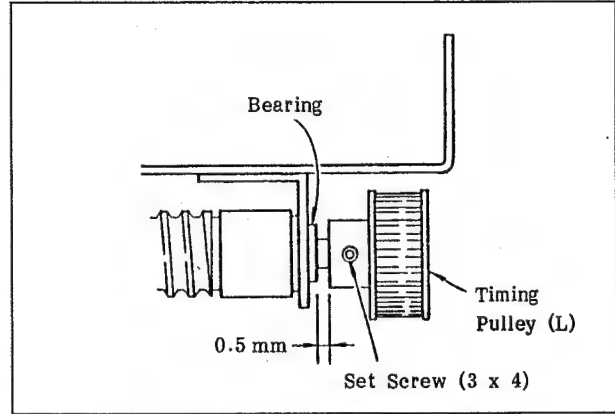

Fig. 6-37 Attaching the Timing Pulley

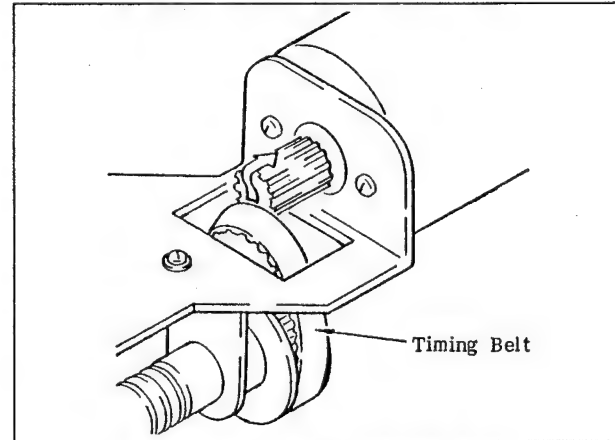

Fig. 6-38 Attaching the Timing Belt

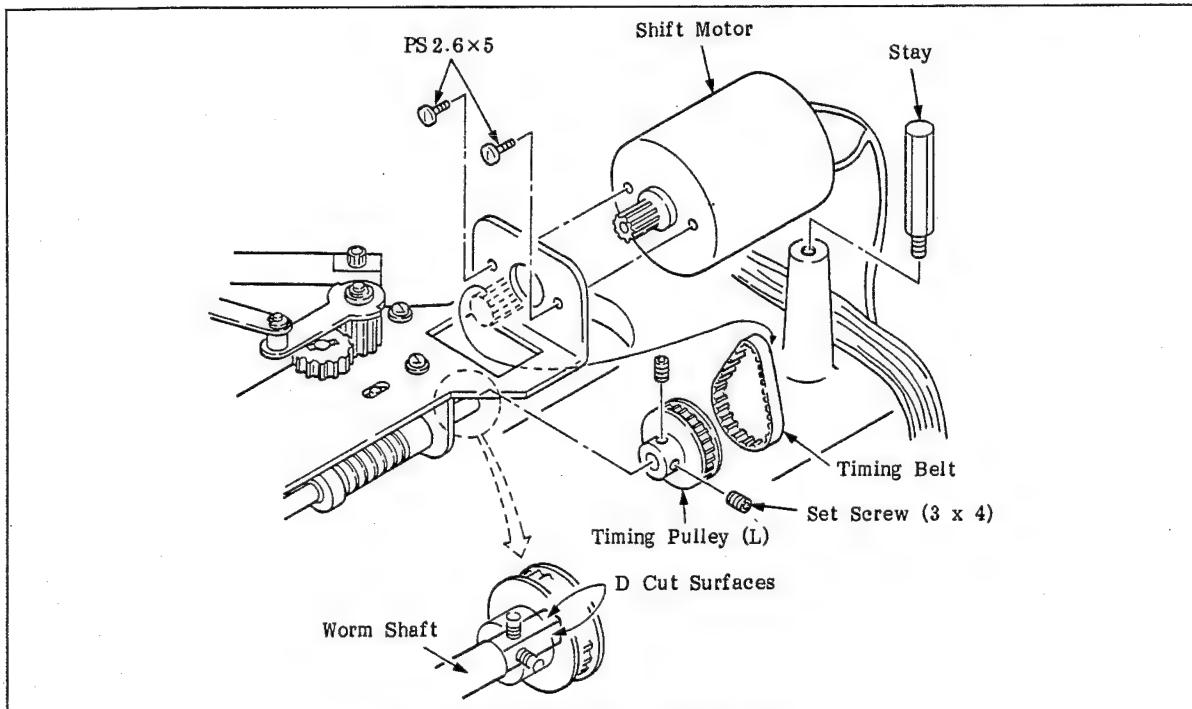

Fig. 6-39 Replacing the Timing Pulley

6-8-2. Replacement of Spur Gear (A or B)

Background Knowledge

- A. When replacing the spur gear with a new one, also replace the crankshaft on which the gear is mounted, so that the phase can be matched accurately. (Refer to Figure 6-36.)
- B. The worm wheel can also be replaced according to the following procedure.

Replacement

1. Unscrew the six screws that hold the cassette compartment and remove it.
2. Remove the crank assembly by referring to Figure 6-36.
3. Remove the E ring (E3) from the crankshaft, and then unscrew the two set screws (3 x 4) that hold the worm wheel.
4. Remove the parallel pin from the crankshaft and insert it into the new crankshaft.
5. Replace spur gear (A or B) with a new one, and then turn the crank arm in the direction of the arrow shown in the drawing (Figure 6-40 in case of spur gear A, or Figure 6-41 in case of spur gear B). Assemble the components so that the two tap holes of worm wheel (A or B) are in the positions as shown in the figures.
Note: Leave the two set screws (3 x 4) loose enough to allow the spur gear to move.
6. Mount the crank assembly on the machine by referring to Figure 6-36.

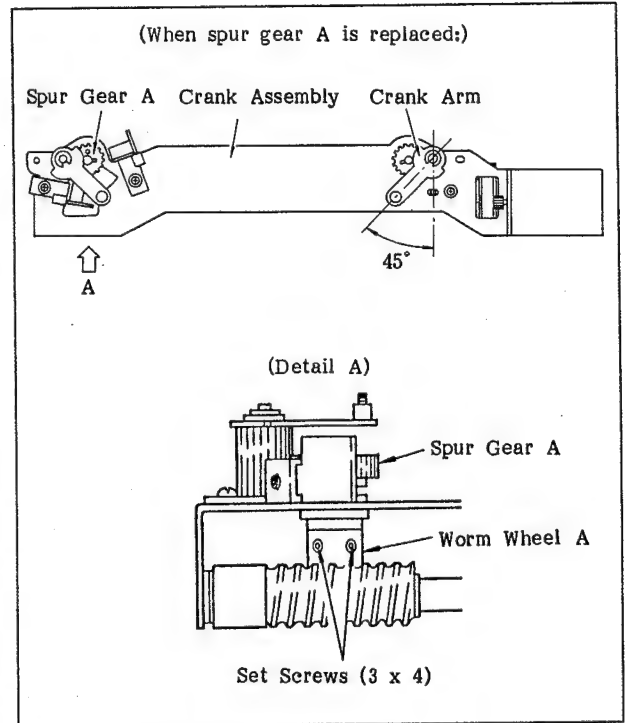

Fig. 6-40 Replacing Spur Gear A

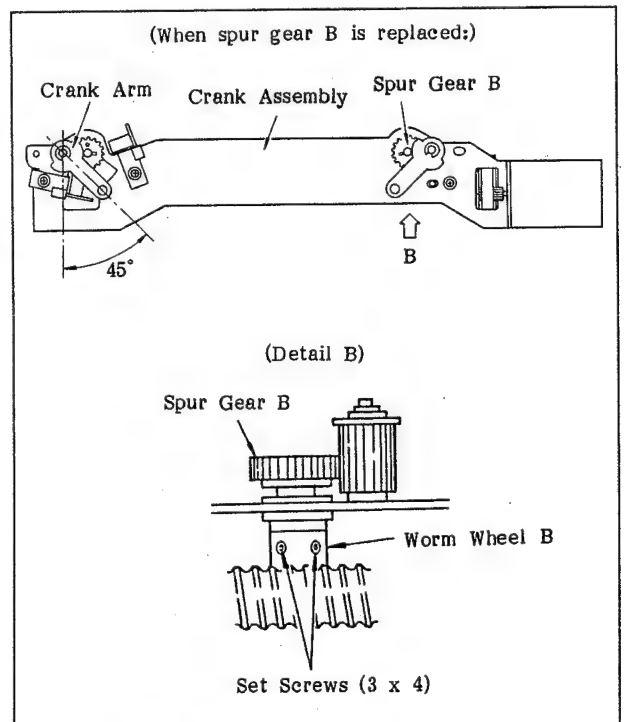

Fig. 6-41 Replacing Spur Gear B



Adjustment of the Phase

7. Shift the reel motor to the M cassette position by rotating the timing pulley (L) manually.
8. Set the worm wheel so that the amounts of the limiter spring compression of the S-side and T-side (Cs and Ct) is more than 0.5 mm, and then slightly tighten the set screws that hold the worm wheel.
9. Shift the reel motor to the L cassette position by rotating the timing pulley (L) manually.
10. Confirm that the amounts of the limiter spring compression of the S-side and the T-side is more than 0.5 mm. If it is, tighten the two set screws that hold the worm wheel securely. If it is not, repeat the procedure from step 7.

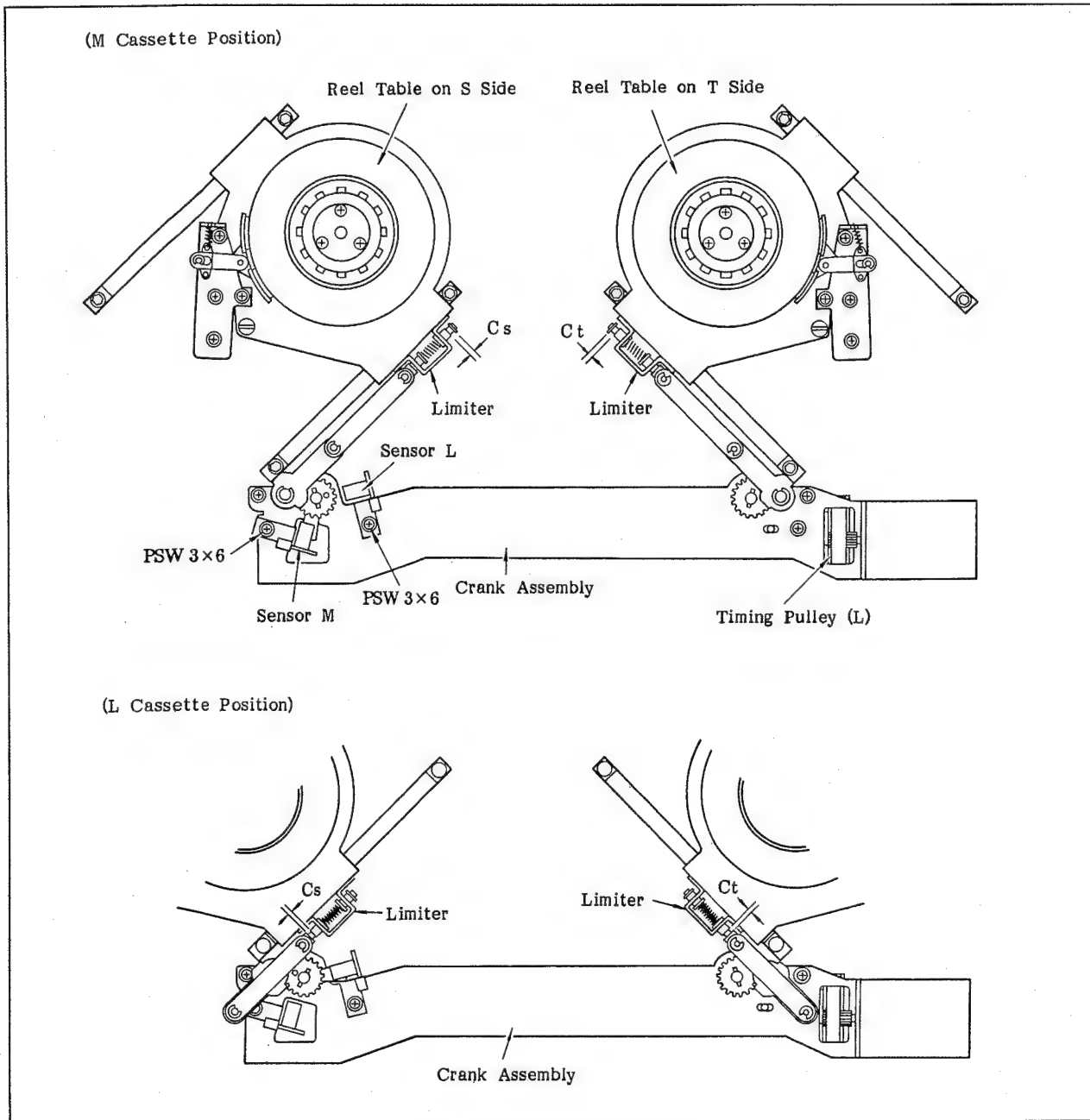

Fig. 6-42 Adjusting the Phase

Adjustment of the Position of the Sensor

11. Turn the power of the machine on.
12. Press the **TEST**, **F3**(CHECKER), **F1**(CONTINUE), **F3**(C), **4**, **SET**, **F6**(F), **0**, **SET** keys on the control panel in that order.
13. Rotate the timing pulley (L) manually and set the reel motor so that the amount of the limiter compression (Cs or Ct, whichever is smaller) is between 0.5 and 1.0 mm in the position for the M cassette.
14. Loosen the screw that holds the sensor M. Move the sensor M and stop it when the indication "a" on the control panel shown in the upper drawing of Figure 6-43 changes from 0 to 1. Fasten the sensor M securely at that position.
15. Rotate the timing pulley (L) manually and set the reel motor so that the amount of the limiter compression (Cs or Ct, whichever is smaller) is between 0.5 and 1.0 mm in the position for the L cassette.
16. Loosen the screw that holds the sensor L. Move the sensor L and stop it when the indication "b" on the control panel shown in the lower drawing of Figure 6-43 changes from 1 to 0. Fasten the sensor L securely at that position.
17. Attach the cassette compartment by referring to section 6-4.

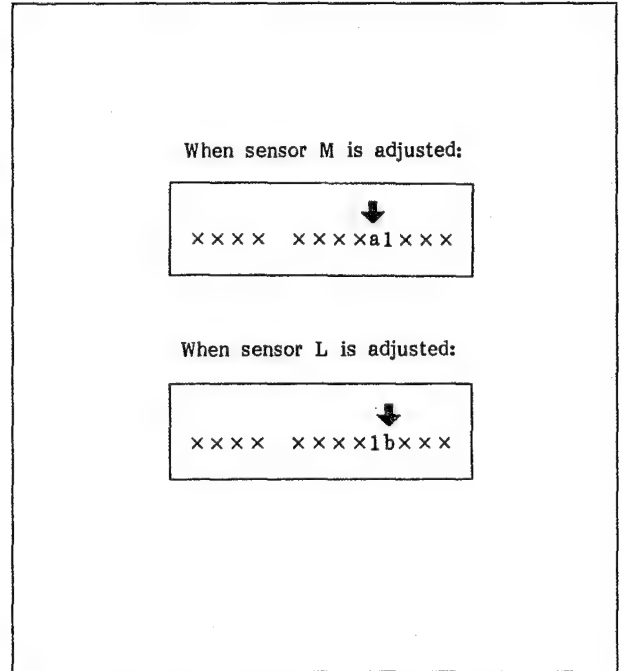

Fig. 6-43 Adjusting the Sensor Position



6-8-3. Replacement of the Worm

Background Knowledge

A. Refer to the following procedure also in replacing the worm shaft or bearing.

Replacement

1. Unscrew the six screws that hold the cassette compartment and remove it.
2. Remove the crank assembly by referring to Figure 6-36.
3. Remove the timing belt, shift motor, and timing pulley (L) in that order.
4. Remove the worm bearing holder and replace the worm with a new one.
5. Turn the S-side and T-side crank arms into the directions shown in Figure 6-44. Then, assemble the worm, worm shaft, worm bearing holder, and poly-washer bearing.
6. Insert the timing pulley (L) so that the D cut surfaces of the worm shaft match the two tap holes of the timing pulley. Then, insert a 0.5 mm thickness gauge between the bearing and timing pulley (L) and fasten the timing pulley by securing with two set screws while pushing the timing pulley (L) into the bearing.
7. Attach the shift motor and fasten it with two screws (PS2.6 x 5), and then set the timing belt.
8. Loosen the two set screws that hold the S-side worm wheel.

Adjusting the Phase

9. Adjust the phases of the S and T reel tables by performing steps 7 to 10 in section 6-8-2.

Adjusting the Sensor Position

10. Adjust the positions of the sensor M and the sensor L by performing steps 11 to 16 in section 6-8-2.
11. Attach the cassette compartment by referring to section 6-4.

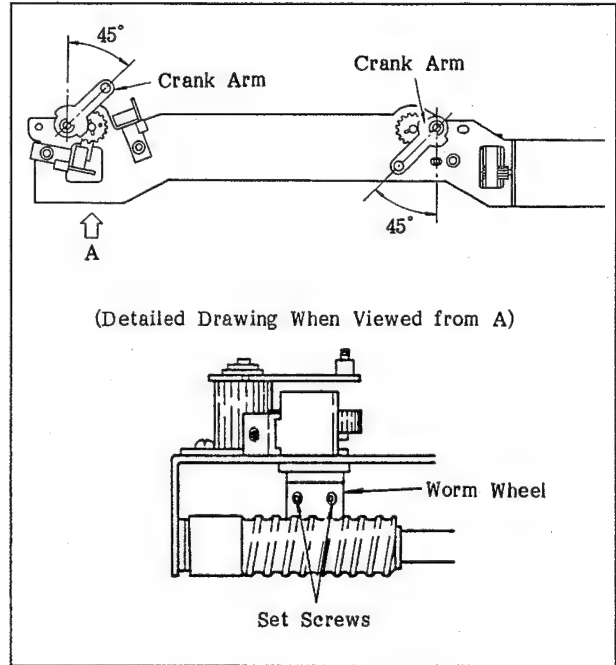

Fig. 6-44 Replacing the Worm

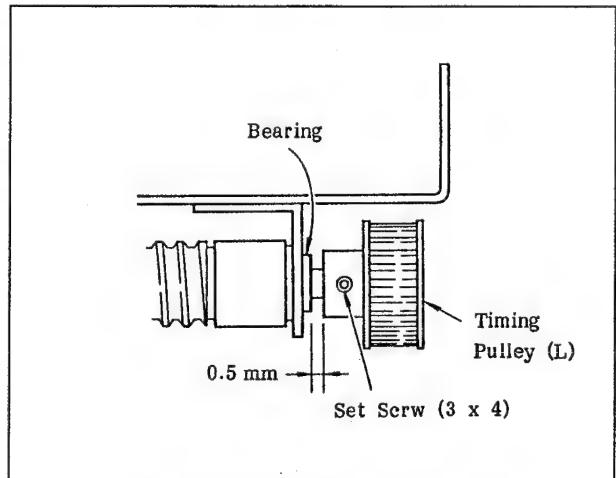

Fig. 6-45 Mounting the Timing Pulley

6-9. REPLACEMENT OF THE S GUIDE BLOCK

Background Knowledge

- A. Refer to this section for replacement of guide roller S5 and its components. Replacement can also be made in the same way. But in this case, it is not necessary to check the zenith of the S5 guide.
- B. Use the following tools for replacement.
- . Guide S5 Zenith Check Tool: J-6252-360-A
 - . Reel Table Height Adjustment Tool: J-6252-190-A
 - . Slant Check Master: J-6252-730-A
 - . Reel Plate: J-6251-170-A

Preparation that must be made before replacing

1. Place the guide S5 zenith check tool on the slant check master and push the guide S5 zenith check tool in the direction of the arrow as shown in Figure 6-46-1. Then, adjust the dial gauge so that the pointer points at 0.
2. Remove the cassette compartment by referring to section 6-4.

Replacement

3. Replace the S guide block by referring to Figure 6-46-2. (Replacement can be made easily, so the detailed procedure will not be explained here.)

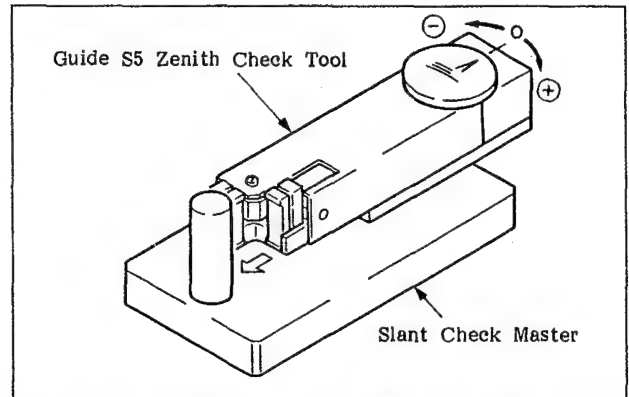

Fig. 6-46-1 Preparation that Must be Made before Making Adjustment

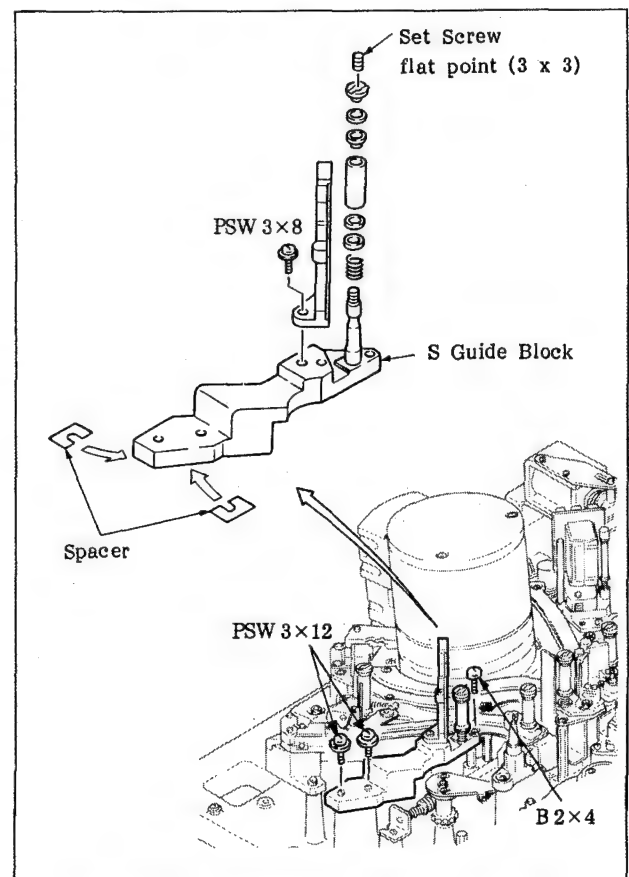

Fig. 6-46-2 Replacement of the S Guide Block

Adjustment of the inclination of the S5 guide roller

4. Check that the movement of the pointer of the dial gauge in both directions X and Y meets the following specification when the inclination of the S5 guide roller is measured by the guide S5 zenith check tool as shown in Figure 6-47.

Spec.: $\pm 20 \mu\text{m}$ in both directions X and Y

5. If the specification is not met, loosen the screws shown in Figure 6-47 by two or three turns and insert the spacer as shown in Figure 6-46-2 and again tighten the two screws firmly, and then check the inclination in step 4.

Spacer

| Thickness (μm) | Part Number |
|-----------------------------|--------------|
| 10 | 3-715-319-01 |
| 20 | 3-715-319-11 |
| 30 | 3-715-319-21 |
| 50 | 3-715-319-31 |

Adjustment of the height of the S5 guide roller

6. Adjust the height of the S5 guide roller by rotating the cap so that the upper flange of the S5 guide roller matches the reel table height adjustment tool as shown in Figure 6-48.
7. Tighten the set screw located on the top of the cap firmly, and then check the height of the upper flange again. If it is not satisfied, perform step 6 again.
8. Attach the cassette compartment by referring to section 6-4.

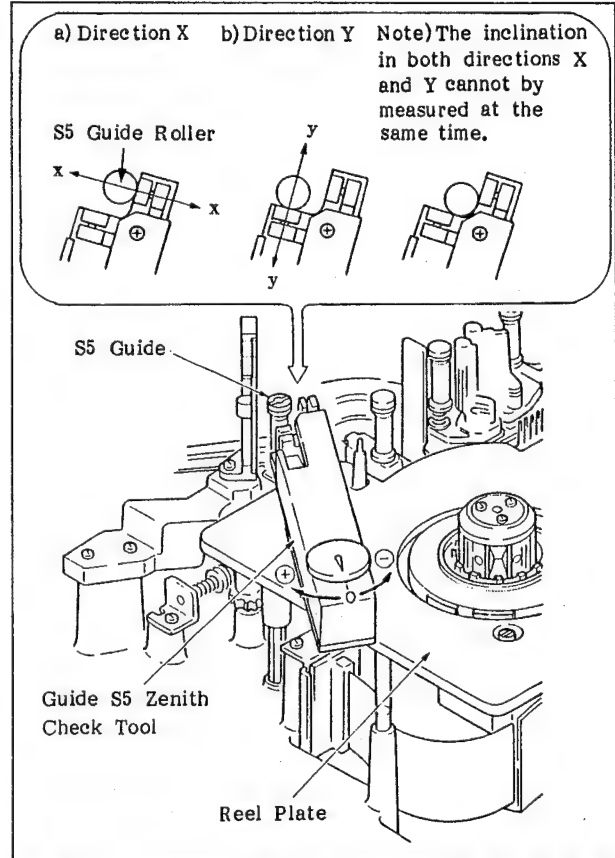

Fig. 6-47 Adjustment of the Inclination of the S5 Guide Roller

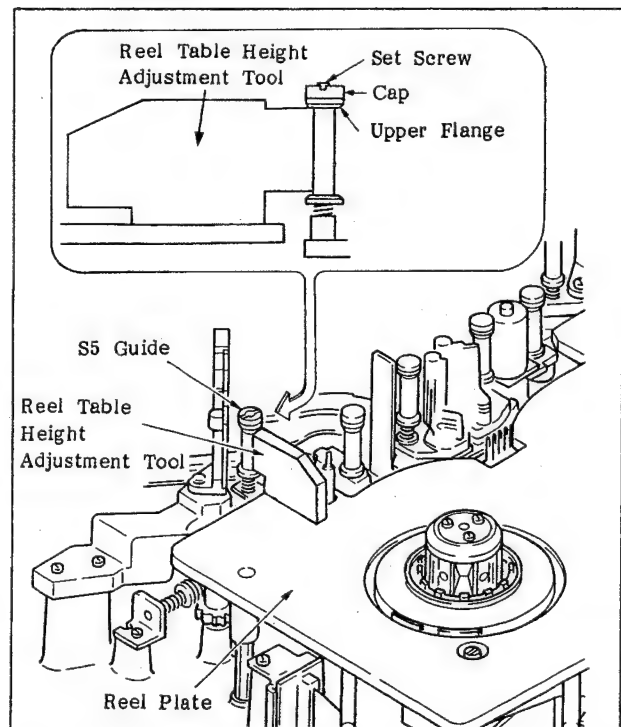

Fig. 6-48 Adjustment of the Height of the S5 Guide Roller

6-10. REPLACEMENT OF THE S DRAWER SLIDER

Background Knowledge

Use the following tool for adjustment to be made after replacement.

S Plate Adjustment Tool: J-6252-200-A

Replacement

1. Rotate the threading motor manually to set the S drawer block in threading condition and remove the SS rail as shown in Figure 6-49.
2. Rotate the threading motor manually to back the S drawer block a little. Then, remove the S drawer block assembly by rotating it as shown in Figure 6-49.
3. Replace the S drawer block by referring to Figure 6-49.
4. Attach the components by performing steps 1 and 2 in reverse order and apply grease to the places shown in Figure 6-49.

Note 1: Be careful when applying grease. If grease adheres to the guide roller, flange, or other portions, completely wipe it off.

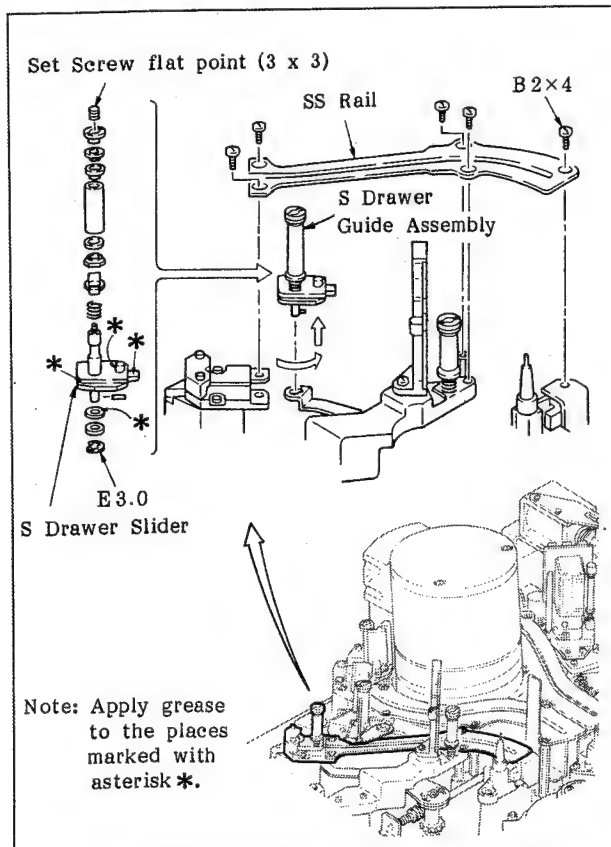

Fig. 6-49 Replacement of the S Drawer Slider

Note 2: Attach the SS rail by referring to adjustment 3 "Adjustment of the Position for Attaching the SS Rail" of section 6-13-1.

Adjustment of the clearance between pin and retainer block

5. Set in the threading condition so that there is a clearance between the retainer block and the pin on the S drawing of Figure 6-50(a).
6. Check that clearance A between the S drawer block and the retainer block, shown in Fig. 6-50 (a), is 10 to 40µm by using the following spacers. If it is not, adjust it by replacing the spacer, shown in Fig. 6-50, with one of a different thickness.

Spacer

| Thickness (µm) | Part Number |
|----------------|--------------|
| 10 | 3-716-722-01 |
| 20 | 3-716-722-11 |
| 30 | 3-716-722-21 |

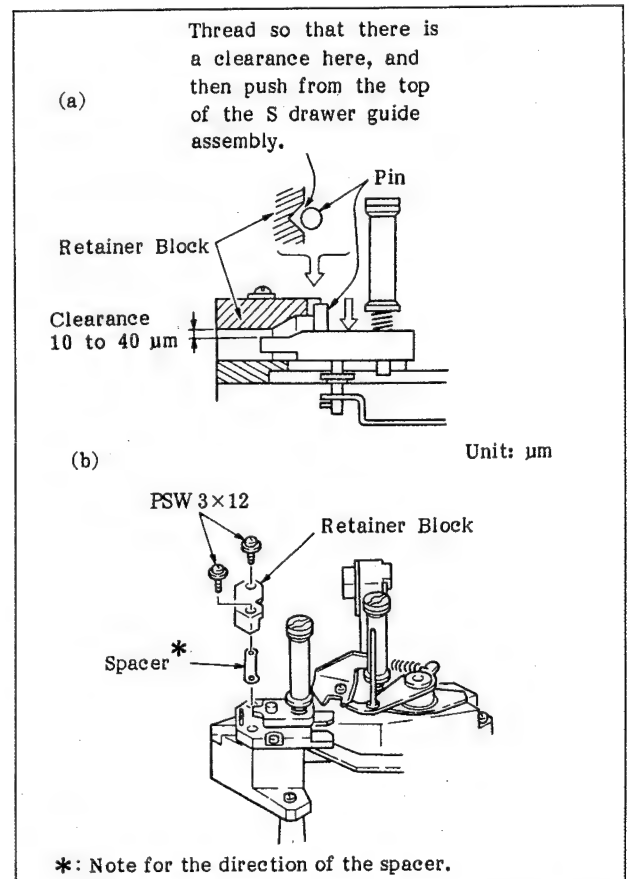

Fig. 6-50 Adjustment of the Clearance between the Retainer Block and the S Drawer Block



Adjustment of the inclination of the S4 guide roller

- 7. Rotate the threading motor manually so that the pin of the S drawer block is in contact with the retainer block.
- 8. Push the S plate tool so that it fits tightly with the S3 guide roller as shown in Figure 6-51(a). Then, check that the clearance between the S4 guide roller and the S plate tool is less than 50 μ m in both upper and lower portions of the S4 guide roller when the S4 guide roller fits together with the S plate tool. If it is not satisfied, adjust it by inserting a spacer as shown in the figure.

Spacer

| Thickness (μ m) | Part Number |
|----------------------|--------------|
| 10 | 3-715-319-1 |
| 20 | 3-715-319-11 |
| 30 | 3-715-319-21 |
| 50 | 3-715-319-31 |

- 9. In a similar manner, check that the clearance between the S4 guide roller and the S plate tool is less than 50 μ m when the S plate tool fits tightly with the S3 guide roller as shown in Figure 6-51 (b). If it is not satisfied, adjust it by inserting a spacer as shown in the figure.
- 10. Make the following adjustment after replacing.
 - 9-2. Adjustment of the Tape Transport

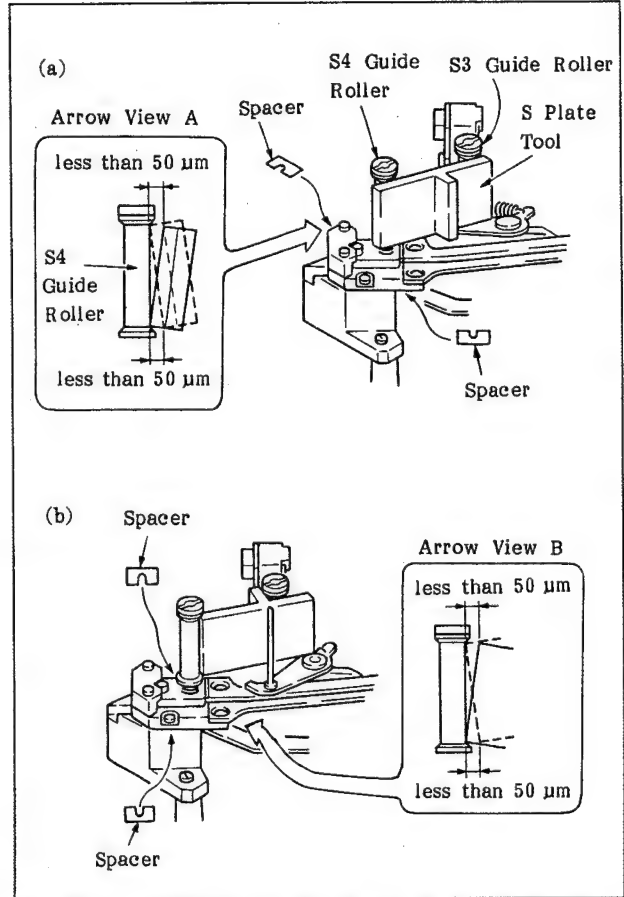

Fig. 6-51 Adjustment of the Inclination of the S4 Guide Roller

6-11. REPLACEMENT OF THE TENSION REGULATOR

Background Knowledge

- A. Refer to Figure 6-52 when replacing the components of the tension regulator. Adjustments to be made after replacement can be made in a manner similar to that of assembling.
- B. Use the following tools for making this adjustment.
 - . S Plate Tool: J-6252-200-A
 - . Tension Arm Bending Tool: J-6253-300-A (J-6041-650-A)

Replacement

1. Remove the 6P connector, CN717, from the mother board.
2. Remove the tension regulator, or the component, and replace it with a new one by referring to Figure 6-52.
3. Reassemble the removed component and attach it to the machine.

Note: Be careful of the position of the notch and the pins, as shown in the upper drawing of Figure 6-52, when attaching the tension regulator assembly.
4. Connect the connector, CN717, that was removed in step 1.

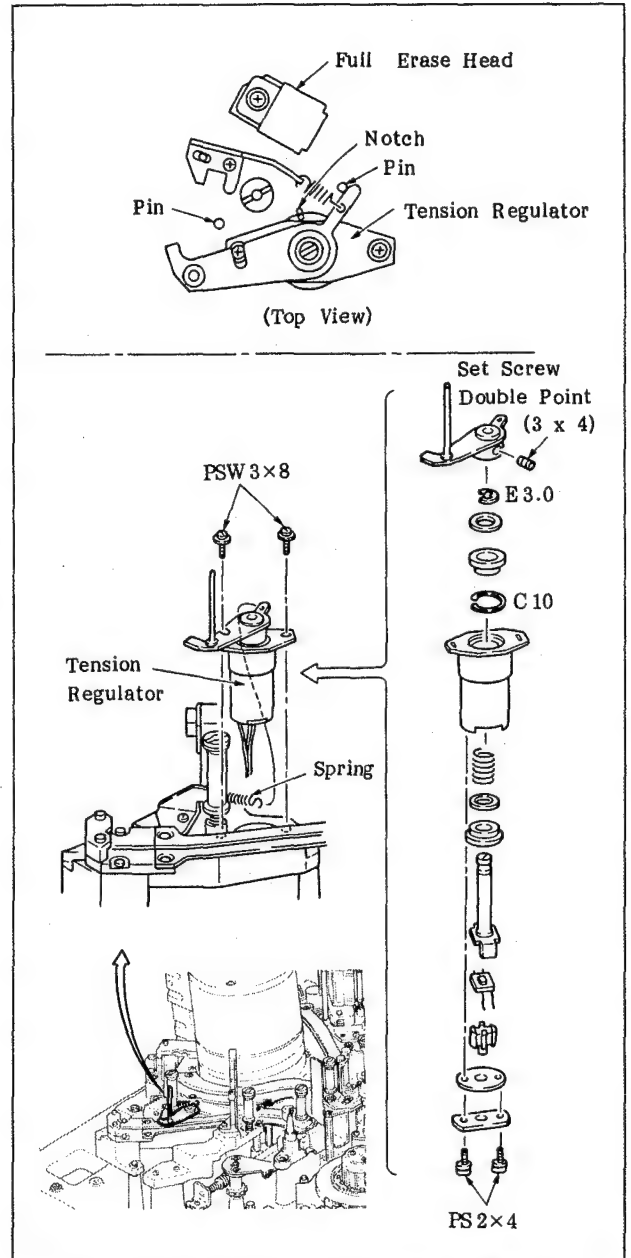

Fig. 6-52 Replacement of the Tension Regulator



Adjustment of the Inclination of the Tension Arm shaft

5. Push the S plate tool so that it fits against the S3 guide roller without clearance, as shown in Figure 6-53(a).

Then, check that the clearance between the tension regulator shaft and the S plate tool in both, the upper and the lower portions is less than $50\ \mu\text{m}$. If it is not, adjust it by bending the portion shown in Figure 6-54 by the tension arm bending tool.

6. In a similar manner, check that the clearance between the tension regulator shaft and the S plate tool is less than $50\ \mu\text{m}$ when the S plate tool fits against the S3 guide roller without clearance, as shown in Figure 6-53(b). If it is not, adjust it by bending the portion shown in Figure 6-54.

7. Make the following checks or adjustments.

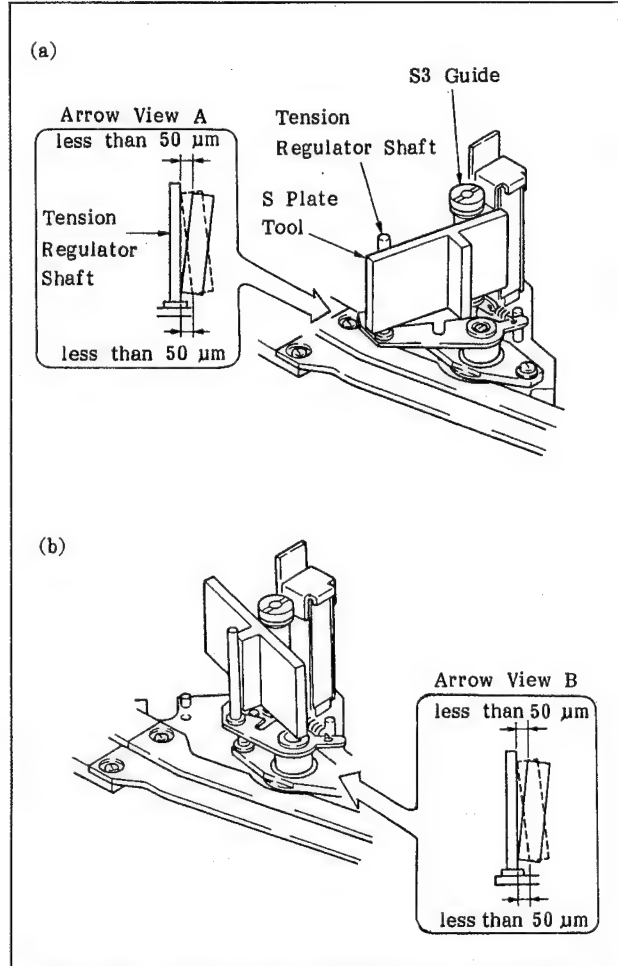
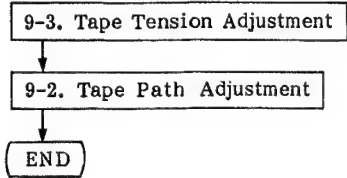

Fig. 6-53 Check of the Inclination of the Tension Arm Shaft

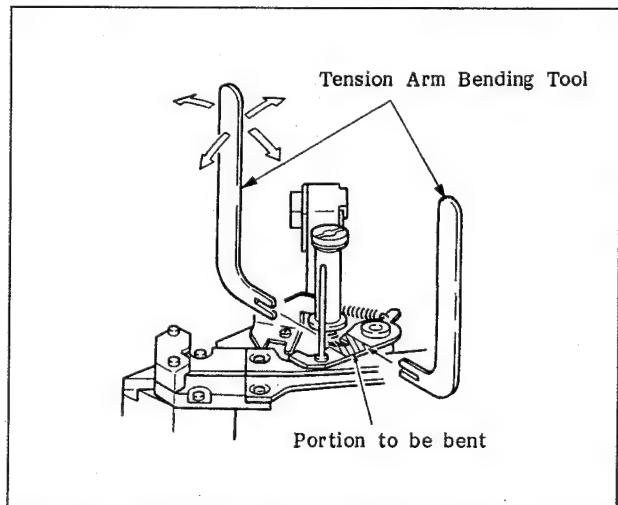

Fig. 6-54 Adjustment of the Inclination of the Tension Arm Shaft

6-12. REPLACEMENT OF THE FULL ERASE HEAD

Replacement

1. Remove the connector, CN434, from the full erase head.
2. Unscrew the screw that holds the full erase head assembly and remove the assembly.
3. Remove the erase head from the full erase head assembly by referring to Figure 6-55.
4. Replace the full erase head with a new one and attach it by performing steps 1 through 3 in reverse order.

Note: To attach the shield case, lightly fix it with one screw (PSW3 x 12) by pushing the shield case in the direction of the white arrow shown in Figure 6-56. (Tighten the screw once, then loosen it by two or three turns.)

Adjustment

5. Thread the tape.
 6. Adjust the full erase head assembly by moving it in the direction of the black arrows shown in Figure 6-56 so that the tape is in contact with the center of the head, and then tighten the screw firmly.
- Note:** Check that the tape is not in contact with the edge of the head.

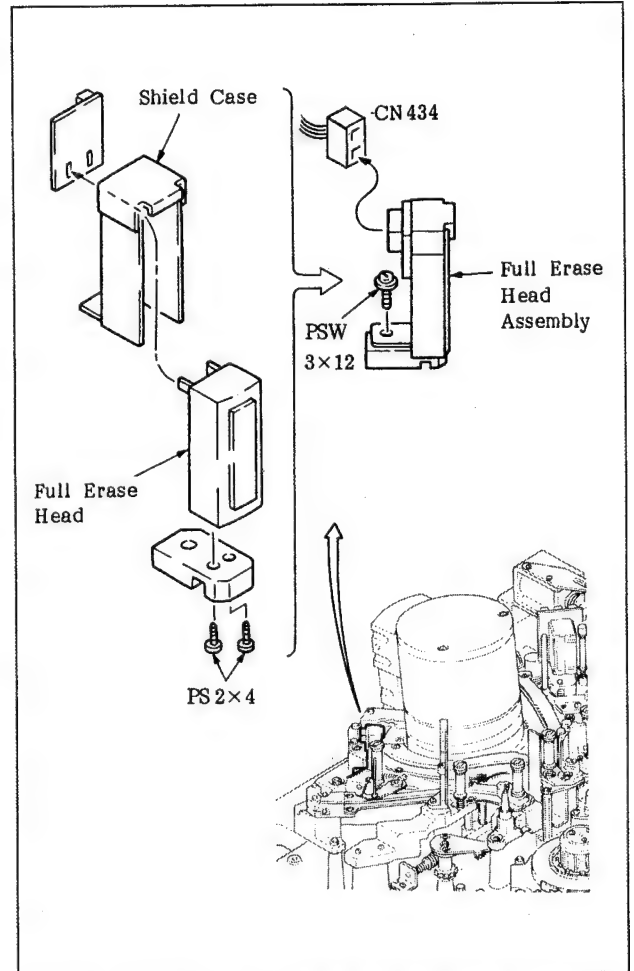

Fig. 6-55 Replacement of the Full Erase Head

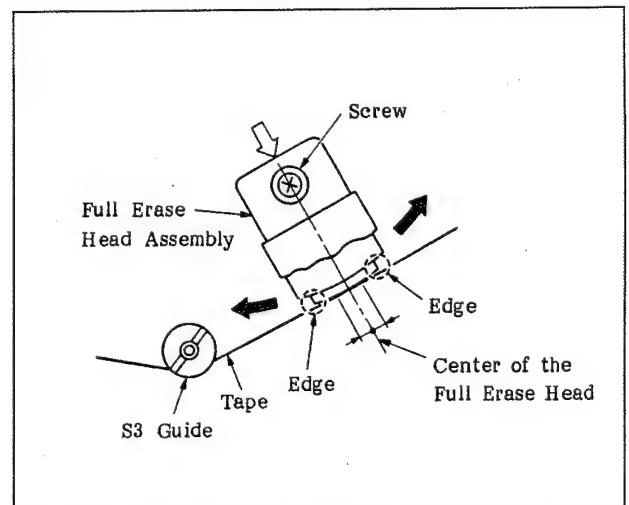

Fig. 6-56 Adjustment of the Position of the Full Erase Head

6-13. Mechanical Components for Threading

6-13-1. Adjustment made after the replacement of the mechanical components for threading

Background Knowledge

This section describes the necessary adjustment that must be made after the mechanical components have been removed or have been replaced with new ones.

Adjustment 1. Adjustment of Clearance between the Link Wheel and the Worm Gear

Use the following tool for adjustment:

Wire clearance gauge

Part Number: J-6152-450-A

- a. Loosen screw S or screw T by two or three turns.
 - b. Insert the 0.3 mm wire clearance gauge between the worm gear and the S/T worm wheel. Tighten screws S/T firmly while pushing the brackets in the direction shown by the arrows in Figure 6-57.
 - c. Remove the 0.3 mm wire clearance gauge, and then check that 0.5 mm wire clearance gauge cannot be inserted in that clearance.
 - d. Rotate the threading motor manually and check that the drive shaft rotates smoothly.
 - e. Loosen the two screws shown in Figure 6-58, and adjust the position of the S or T rotary link by rotating the threading motor manually so that the S drawer block pin touches the retainer block and the T5 guide arm touches the arm stopper at the same time.
- Check that the two screws are approximately at the center of the slotted holes of the rotary link respectively. If they are not, remove the screws and change the engagement position of the S/T wheels and the worm gear. Then repeat this step from the beginning.
- f. Apply grease to the worm gear that meshes with the S and T wheels.

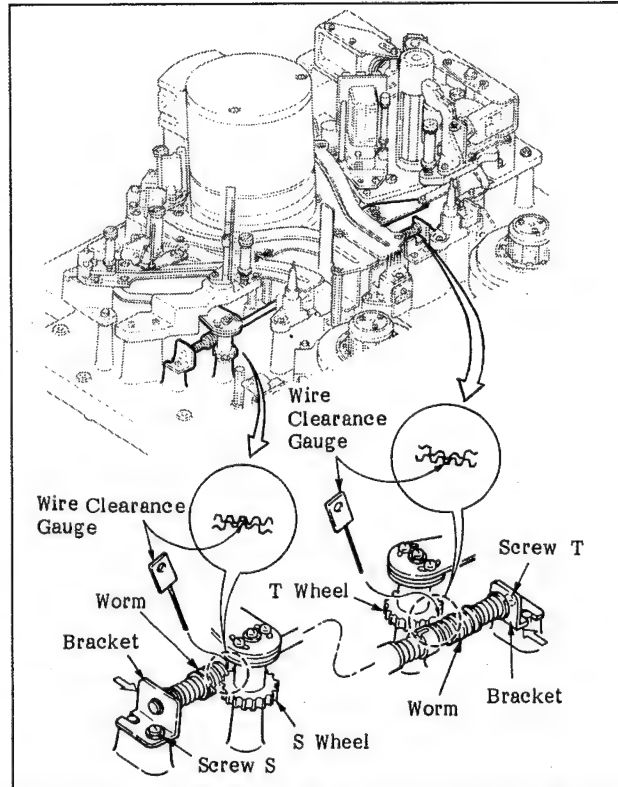

Fig. 6-57. Adjustment of the Clearance between the Link Wheel and the Worm Gear

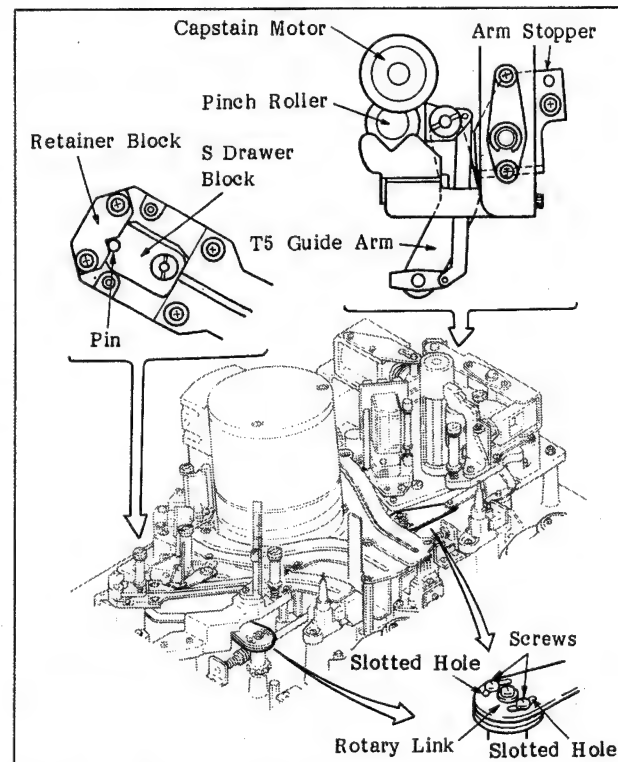

Fig. 6-58. Adjustment of the Position of the S or T Rotary Link

Adjustment 2. Adjustment of the Drive Shaft and Gear H

Use the following tool for adjustment:

Wire clearance gauge.

Part Number: J-6152-450-A

- a. Adjust the position by rotating the threading motor manually so that the S4 guide block, the T5 guide arm, the entrance slant guide block, and the exit slant guide block touch each stopper at the same time (each limiter starts to function), as shown in the four top views in Figure 6-59. If they do not touch at the same time, detach gear H from gear I, and turn the driving shaft manually so that the block touch each stopper at the same time.
- b. Remove the T rail.
- c. Insert the 0.5 mm diameter wire clearance gauge between gear I and gear H, as shown in Figure 6-60. Then, tighten the two screws firmly while pushing gear H in the direction of the black arrow. Remove the wire clearance, and check that the same wire clearance gauge (0.5 mm dia.) can be inserted in the same position smoothly.
- d. Remove the 0.5 mm wire clearance gauge. Then, check that the 0.7 mm wire clearance gauge cannot be inserted in that position.
- e. Attach the T rail and perform adjustment 4.

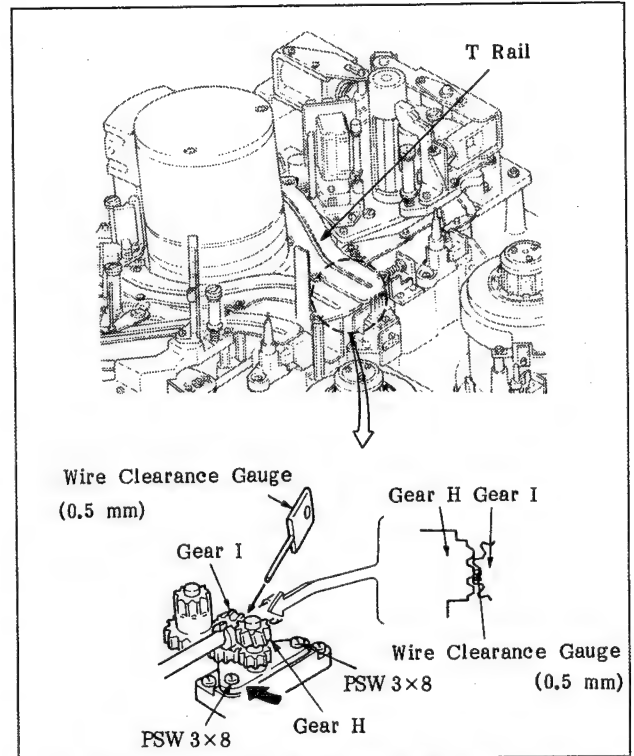

Fig. 6-60. Adjustment of the Drive Shaft and Gear H

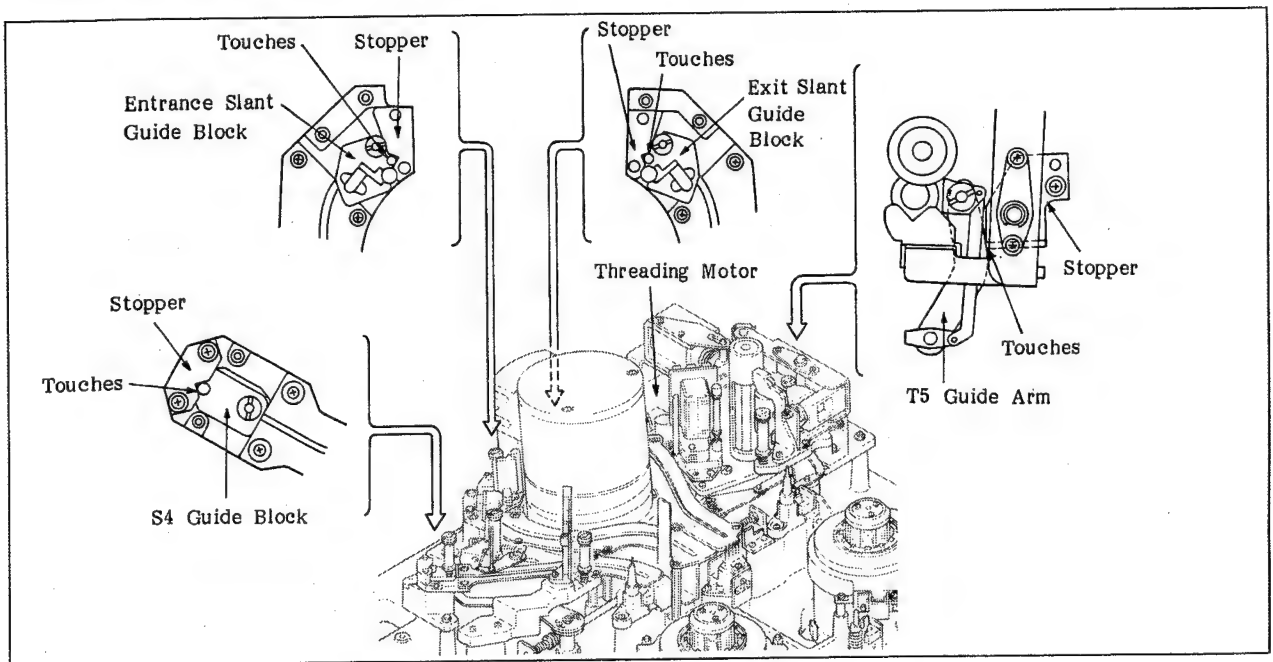

Fig. 6-59. Preparations Made before Adjustment



Adjustment 3. Adjustment of the Position for Attaching the SS Rail

Use the following tool for adjustment:

Guide rail adjustment tool

Part Number: J-6251-160-A

- a. Rotate the threading motor manually so that the S4 guide comes to the position shown in Figure 6-61.
- b. Tighten the five screws that hold the SS rail firmly, and then loosen them by one or two turns.
- c. Place the guide rail adjustment tool in the position shown in Figure 6-61 and push it in the direction of the white arrow.
- d. Tighten the attached five screws firmly while pushing the SS rail in the direction of the black arrows.

Note: Tighten the screws with a torque of 2 kg-cm.

- e. Check that the guide rail adjustment tool can be moved smoothly around the joint portion of the S drawer guide block and the SS rail.

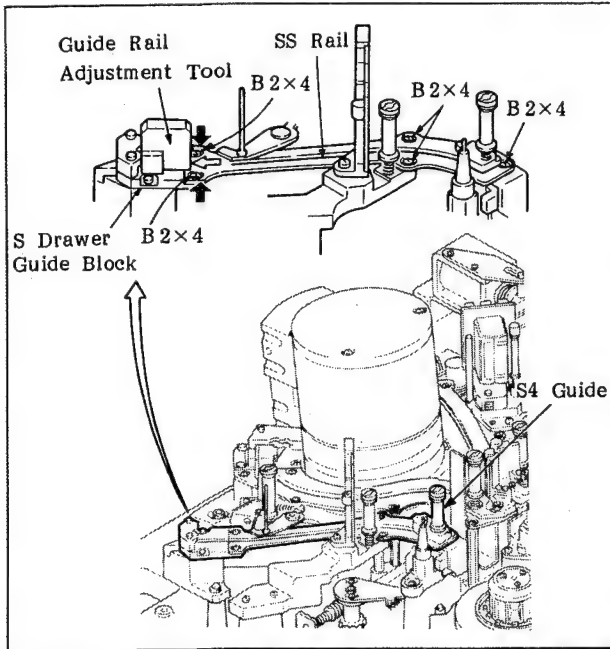

Fig. 6-61. Adjustment of the Attaching Position of the SS Rail

Adjustment 4. Adjustment of the Position of the S and T Rails

Use the following tool for adjustment:

Guide rail adjustment tool

Part Number: J-6251-160-A

Be careful not to damage the rotary head when making this adjustment.

- a. Rotate the threading motor manually so that the entrance and exit slant guide blocks become unthreaded.
- b. Tighten the screws that hold the S and T rails firmly, and then loosen them by one or two turns.
- c. Place the guide rail adjustment tool in the position shown in Figure 6-62, and then push it in the direction of the white arrow.

- d. Tighten the attached screws firmly, while pushing the S and T rails in the directions of the black arrows.

Note: Tighten the screws with a torque of 2 kg-cm.

- e. Check that the guide rail adjustment tool can be moved smoothly around the joint portion of the S/T rail blocks and the S/T rails.

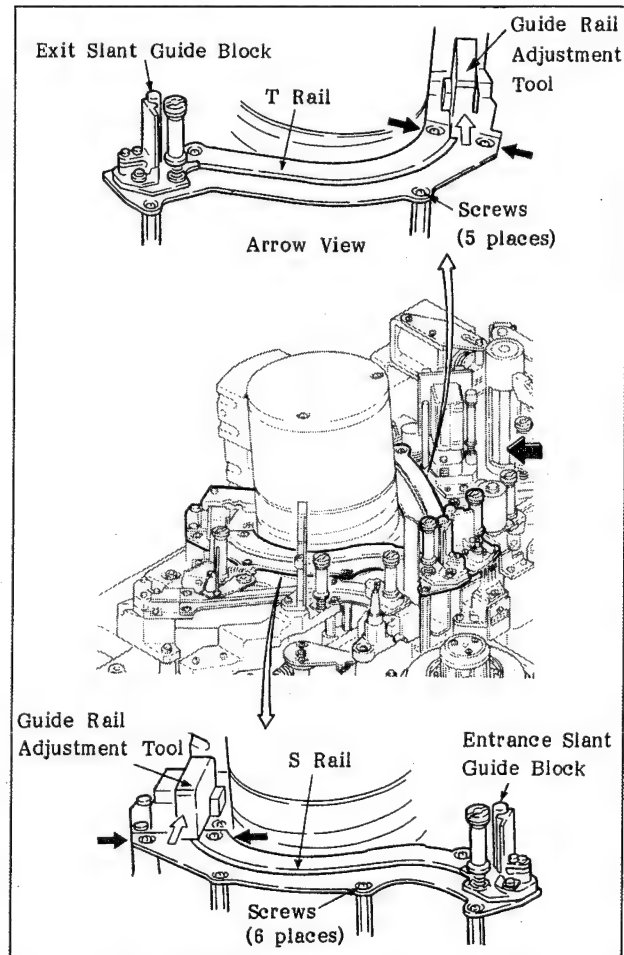

Fig. 6-62. Adjustment of the Position of the S/T Rails

Adjustment 5. Adjustment of the Address of the Potentiometer in Threading Condition

Background Knowledge

It is necessary to perform adjustment 6 (Adjustment of the Address of the Potentiometer in the Unthreading Condition) when this adjustment is performed.

Use the following tool for adjustment:

Dental mirror

Part Number: 7-723-902-00

- a. Turn the power on. Then, press the **TEST**, **F3** (CHECKER), and **F1** (CONTINUE) keys on the control panel in that order to set the machine in CHECKER mode.
- b. Press the **F7** (\$), **A**, **8**, **A**, **1**, **SET** keys on the control panel in that order.
- c. Check that "A8A1-E0" is indicated on the display. If it is not, press the **E**, **0**, and **SET** keys on the control panel in that order, and then go to step d. When it is indicated, press the **SET** key and then go to step g.
- d. Press the **F10** (NVW) and **SET** keys on the control panel.
- e. Press the **/** key after confirming that "A8A1-E0" is indicated on the display.
- f. Confirm that "PUSH NVWR SW" is indicated on the display, and press the switch S1 (NVWR SW) on the SP-01 board.
- g. Press the **F3** (C), **4**, **SET**, **F6** (F), **2**, **SET**, and **<** keys on the control panel in that order to set the machine in threading condition without loading a cassette tape.
- h. Place the dental mirror in a position where the threading gear and the banana link can be observed, as shown in Figure 6-63.
- i. Rotate the threading motor manually so that the edge of the banana link coincides with the marker position on the threading gear.
- j. Check that the two-digit number (address of the potentiometer) shown on the display is "E0 + 1", as shown in Figure 6-63. If it is not satisfied, loosen the two screws (PSW3 x 8) that hold the potentiometer, and then adjust it by rotating the potentiometer. Tighten the two screws firmly after adjustment.
- k. Press the **>** key on the control panel to set the machine in the unthreading condition.
- l. Press the **<** key on the control panel to set the machine in the threading condition again.
- m. Check again that the address of the potentiometer is "E0 + 1" by performing steps h and i. If it is not, adjust the position of the potentiometer.

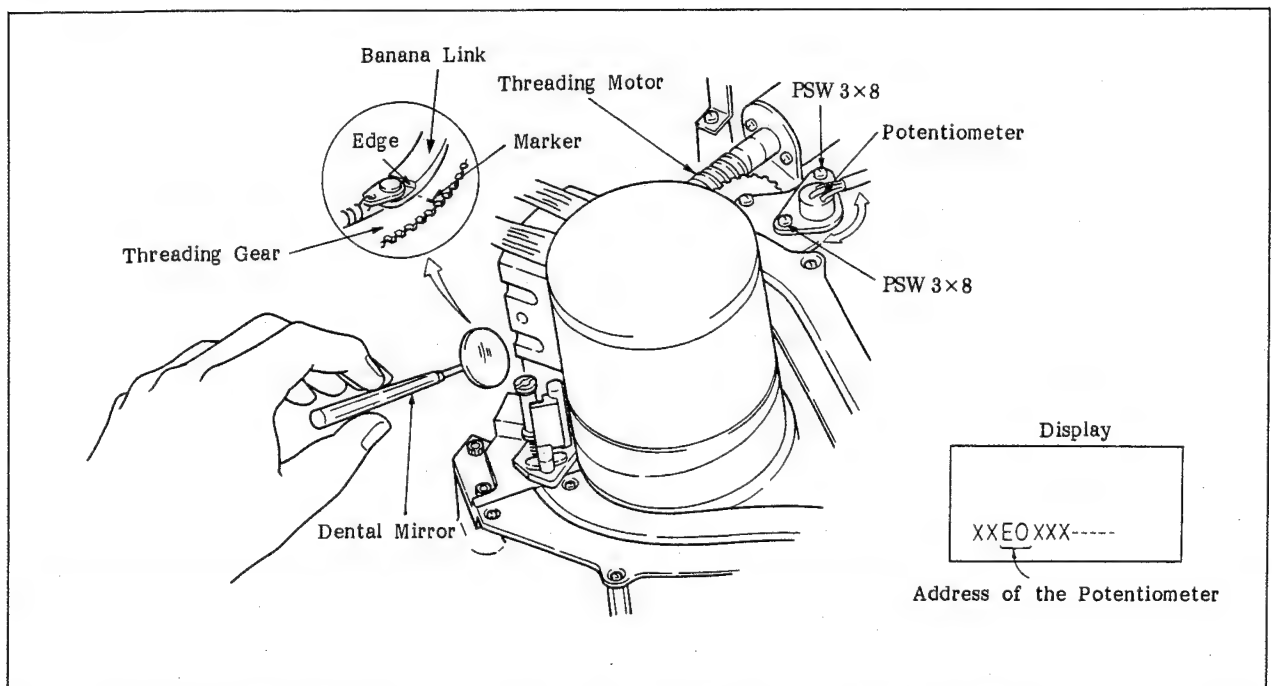

Fig. 6-63. Adjustment of the Address of the Potentiometer in Threading Condition

Adjustment 6. Adjustment of the Address of the Potentiometer in Unthreading Condition

- a. Turn the power on, and then press the **TEST**, **F3** (CHECKER), and **F1** (CONTINUE) keys on the control panel in that order to set the machine in CHECKER mode.
- b. Press the **F3** (C), **4**, **SET**, **F6** (F), **2**, **SET**, and **>** keys on the control panel in that order to set the machine in unthreading condition.
- c. Check that pin S is in contact with pin T as shown in Figure 6-63. If it is not, rotate the threading motor manually so that pin S becomes in contact with pin T.
- d. Remember the two-digit number on the display, shown in Figure 6-64.
- e. Press the **F7** (\$), **A**, **8**, **0**, **SET** keys on the control panel in that order.
- f. Input the value in which 2 has been added to the data obtained in step d, and then press the SET key.
- g. Press the **F10** (NVW) and **SET** keys on the control panel.
- h. Check that "A8A0-□□" (1-byte data that was inputted in step f) is indicated on the display, and then press the **/** key.
- i. Check that "PUSH NVWR SW" is indicated on the display, and then press switch S1 (NVWR SW) on the SP-01 board.

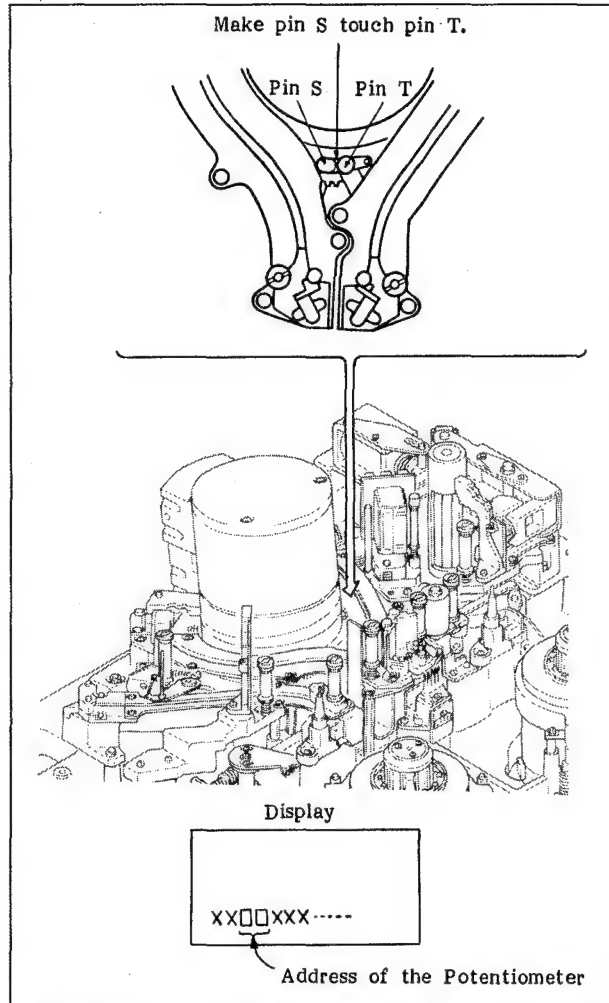

Fig. 6-64. Adjustment of the Address of the Potentiometer in Unthreading Condition



6-13-2. Replacement of Link Wheels S/T

Replacement

1. Rotate the threading motor manually so that the rotary links S/T are in the positions shown in Figure 6-65.
2. Replace link wheel S with a new one by referring to Figure 6-66, and link wheel T by referring to Figure 6-67.

Adjustment

3. Perform adjustment 1 (adjustment of the clearance between the link wheel and the worm gear) in section 6-13-1.

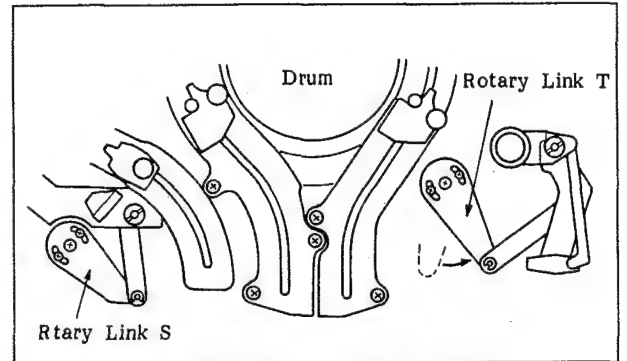

Fig. 6-65. Replacement of Link Wheels S/T

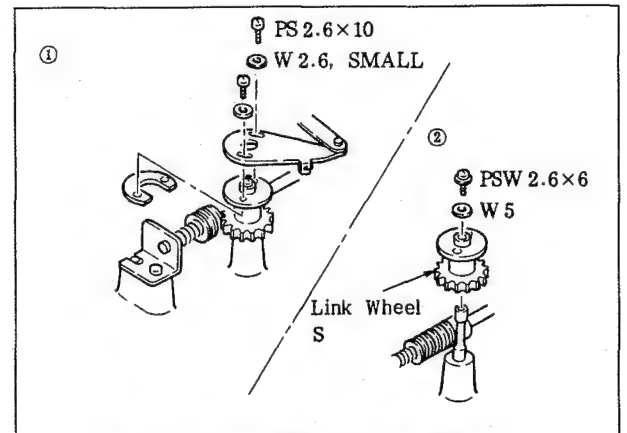

Fig. 6-66. Replacement of Link Wheel S

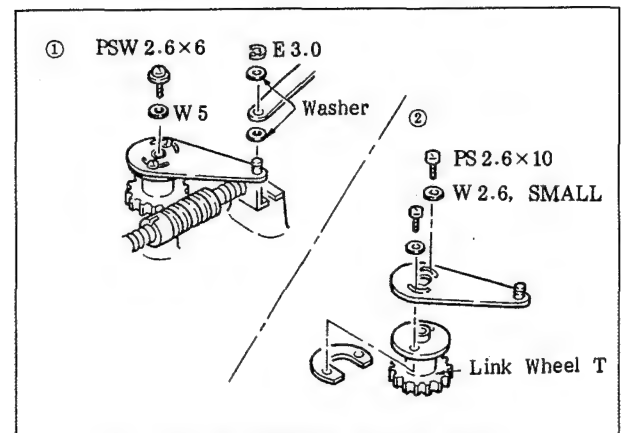

Fig. 6-67. Replacement of Link Wheel T



6-13-3. Replacement of Components of the Drive Shaft Assembly

Replacement

1. Remove the S and T rails, and the drive shaft assembly by referring to Figure 6-68.
2. Replace the necessary components of the drive shaft assembly by referring to Figure 6-69.
3. Attach the components that were removed by referring to Figures 6-68 and 6-69.

Note: Tighten the screws (B2 x 4) that hold the S and T rails with a torque of 2 kg-cm.

Adjustment

4. Perform the following adjustments in section 6-13-1.
Adjustment 1. Adjustment of the clearance between the link wheel and the worm gear
Adjustment 2. Adjustment of the drive shaft and gear H
Adjustment 4. Adjustment of the position of the S and T rails

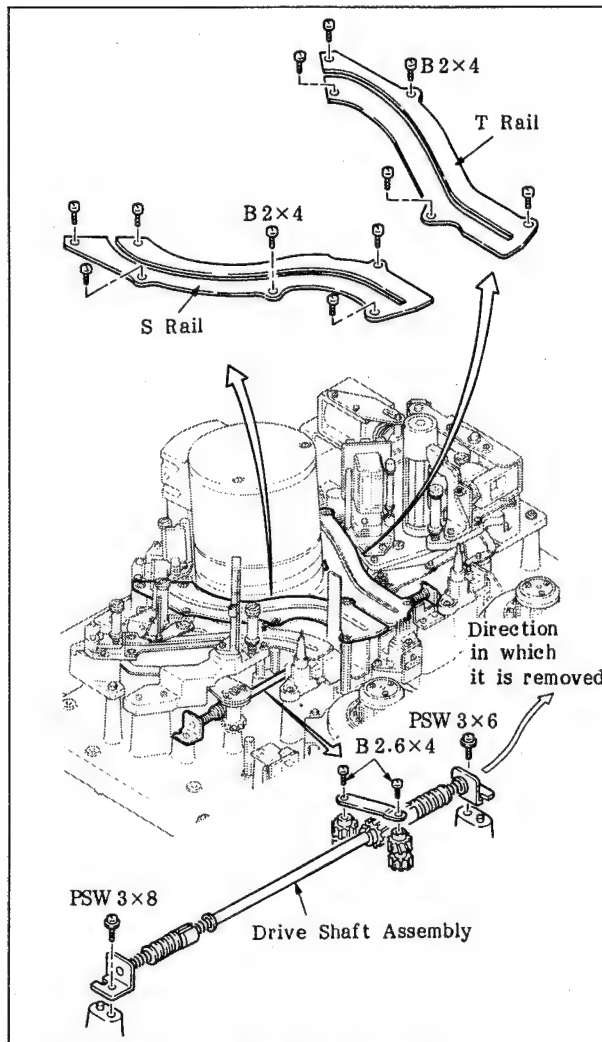

Fig. 6-68 Remove the Drive Shaft Assembly

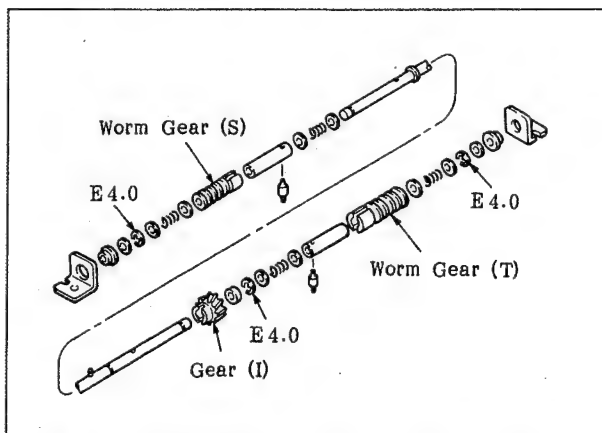

Fig. 6-69 Replacement of the Drive Shaft Assembly

6-13-4. Replacement of Gears H and G

Replacement

1. Remove the H/G gear assembly by referring to Figure 6-70.
2. Replace the necessary components of the H/G gear assembly.
3. Attach the removed components.

Note: Tighten the screws (B2 x 4) that hold the T rail with a torque of 2 kg-cm.

Adjustment

4. Make the following adjustments by referring to section 6-13-1.
 - Adjustment 2. Adjustment of the drive shaft and gear H
 - Adjustment 4. Adjustment of the position of the S and T rails

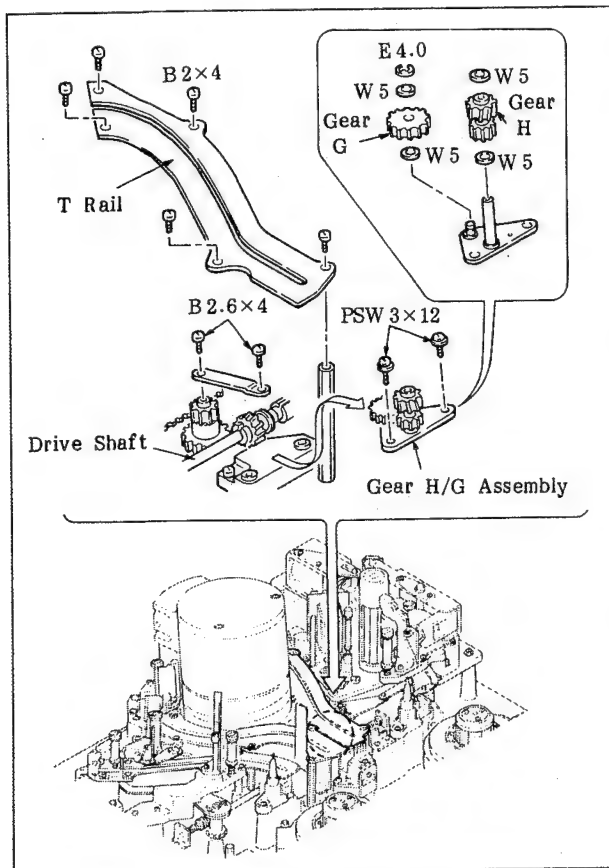

Fig. 6-70 Remove the H/G Gear Assembly

6-13-5. Replacement of Components of the Gear Box Assembly

Background Knowledge

Use the following tool for replacement.

Wire Clearance Gauge Set
Part Number: J-6152-450-A

1. Unscrew the two screws as shown in Figure 6-71, and then remove the threading motor assembly.
2. Unscrew the three screws, and then remove the gear box assembly.
3. Replace the necessary components with new ones by referring to Figure 6-72.

Note: When the potentiometer or gear E has been replaced with a new one, attach it so that the head of the potentiometer shaft and the edge of gear E are on the same side, as shown in the detailed drawing of Figure 6-72.

4. Attach the gear box assembly to the machine.
5. Attach the threading motor assembly to the machine.
6. Insert the 0.3 mm diameter wire clearance gauge between gear A and the worm gear as shown in Figure 6-73, and then tighten the two screws (PSW3 x8) firmly while pushing the threading motor assembly in the direction of the arrow. Check that the 0.5 mm diameter wire clearance gauge cannot be inserted in that clearance.
7. Check that the entrance and exit slant guide blocks are in contact with each stopper at the same time as shown in Figure 6-74. If it is not, adjust it by rotating the gears in the directions of the black arrows while pushing the gear box assembly in the direction of the white arrow.

After completion of the adjustment, tighten the three screws (PSW3 x 8) firmly.
8. Adjust the position of the potentiometer by referring to adjustments 5 and 6 in section 6-13-1.

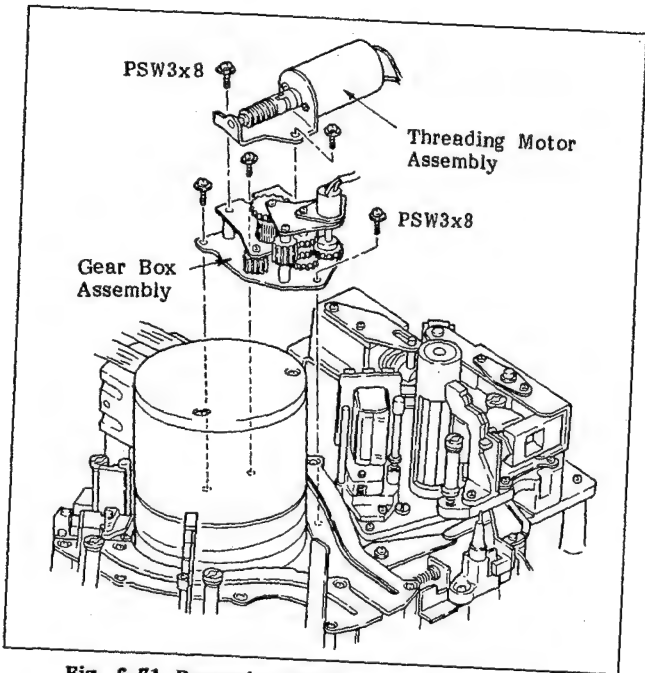

Fig. 6-71 Removing the Gear Box Assembly

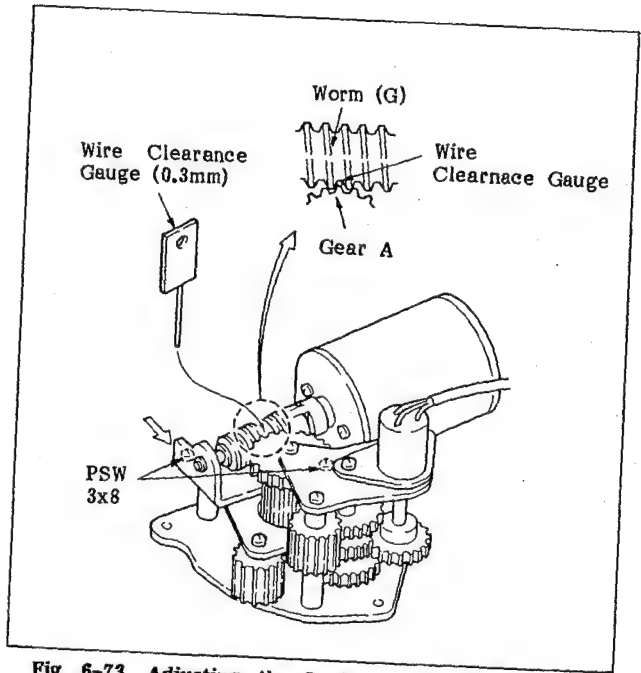

Fig. 6-73 Adjusting the Position of the Threading Motor Assembly

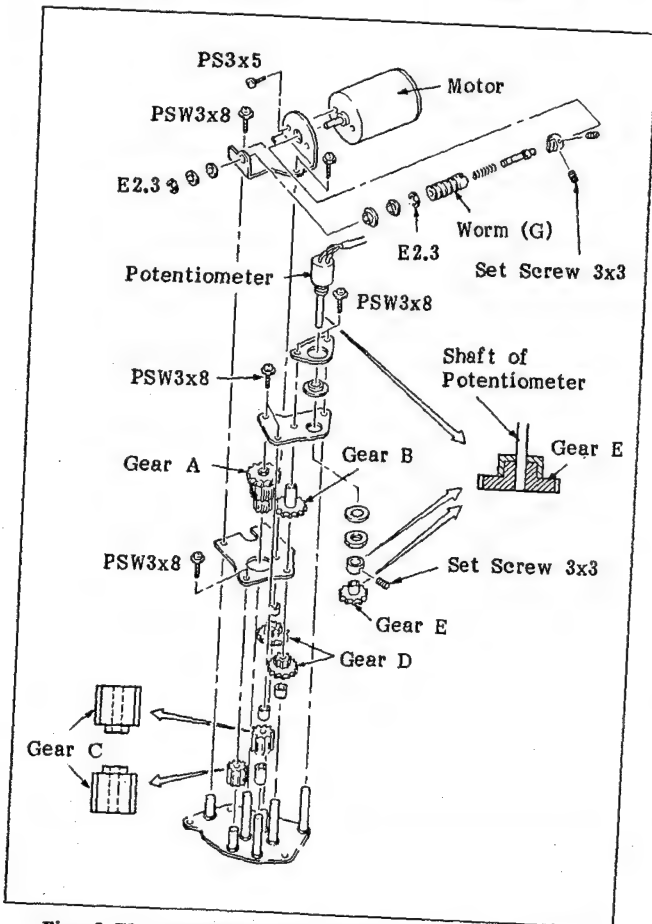

Fig. 6-72 Replacing the Components of the Gear Box Assembly

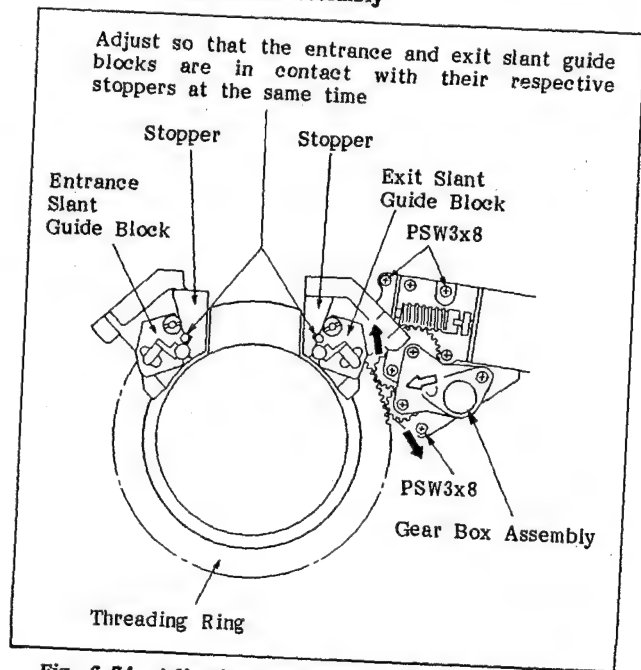

Fig. 6-74 Adjusting the Position of the Gear Box Assembly

6-14. CAPSTAN MOTOR

6-14-1. Replacement of the Capstan Motor

Background Knowledge

A. Use the following tools for making the adjustments.

Reel Plate: J-6251-170-B

Guide T6 Zenith Check Tool: J-6252-370-A

Capstan Shaft Adjustment Tool: J-6253-180-A

Slant Check Master: J-6252-730-A

B. Adjust the guide T6 zenith check tool before using it by referring to section 2-9.

C. When checking the inclination of the T6 guide, push the guide T6 zenith check tool against the guide carefully so that the probe does not touch either the upper or the lower flange. (Figure 6-75)

Replacement

1. Remove the connectors from the end sensor, the solenoid, and the stationary head assembly, and then disconnect the leads from the stationary head assembly.

2. Check whether there are spacers between the capstan base and the screw hole.

3. Remove the three screws that hold the capstan base and the two screws that hold the solenoid shown in Figure 6-76. When there are spacers, make sure to note the types and the number of spacers, and their positions.

Note: When placing the capstan motor assembly on the table as shown in Figure 6-77, make sure that no force is placed on the capstan.

4. Remove the three screws that hold the capstan motor and replace it with a new one, then tighten the screws again.

5. Attach the capstan motor assembly to the machine by referring to Figure 6-76. If spacers were used before removal, place them in their original positions.

6. Connect the leads and the connector that were removed in step 1.

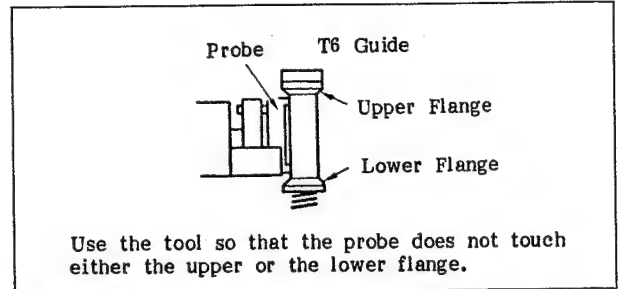

Use the tool so that the probe does not touch either the upper or the lower flange.

Fig. 6-75 Precautions on the Usage of the Guide T6 Zenith Check Tool

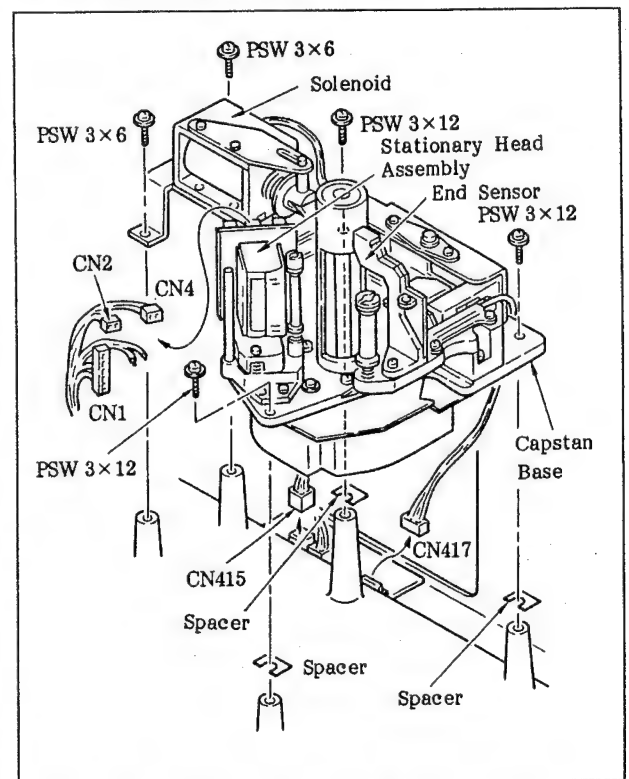

Fig. 6-76 Remove the Capstan Motor Assembly

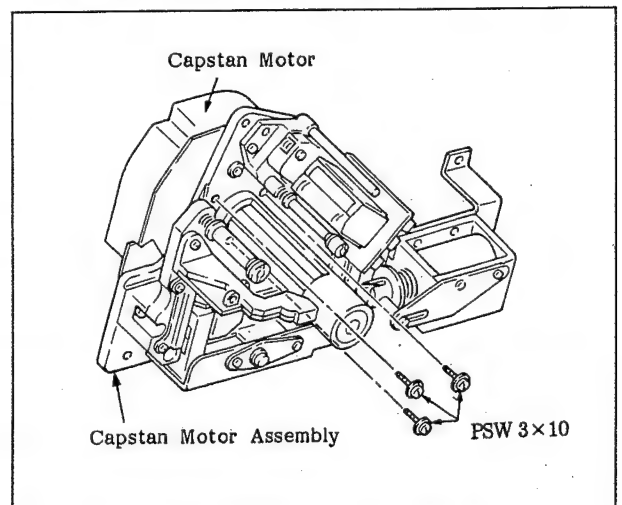

Fig. 6-77 Replacement of the Capstan Motor

Adjustment of the Capstan Motor Shaft

7. Remove the pinch press arm, END sensor, and harness holder by referring to Figure 6-78.
8. Set the reel plate.
9. Measure the inclination of the T6 guide in directions x and y and note the results.
10. Clean the surface of the V groove of the capstan shaft adjustment tool and the capstan shaft.
11. Install the capstan shaft adjustment tool by pushing it onto the capstan shaft and then lifting it up until it touches the housing. (Figure 6-80)
12. Push the guide T6 zenith check tool against the capstan shaft adjustment tool, as shown in Figure 6-81, and then check that the inclinations in the x and y directions meet the following specifications.
Spec. Direction x: $\pm 10 \mu\text{m}$
Direction y: $\pm 10 \mu\text{m}$
13. If they do not, insert spacers in the places shown in the Figure 6-76 and then check the inclinations in step 12 again.

Spacer

| Thickness (μm) | Part Number |
|-----------------------------|--------------|
| 10 | 3-715-470-32 |
| 20 | 3-715-470-22 |
| 50 | 3-715-470-12 |
| 100 | 3-715-470-02 |

14. Remove the capstan shaft adjustment tool from the capstan shaft.
15. Measure the inclinations of the T6 guide in the x and y directions by referring to Figure 6-79. Check that the differences between the values measured here and the values measured in step 9 are within $\pm 5\mu\text{m}$.
16. If they are not, adjust the inclinations of the T6 guide by referring to section 6-15-9, "Replacement of the T Roller Base".
17. Replace the pinch press arm, END sensor, and harness holder, which were removed in step 7, in their original positions.

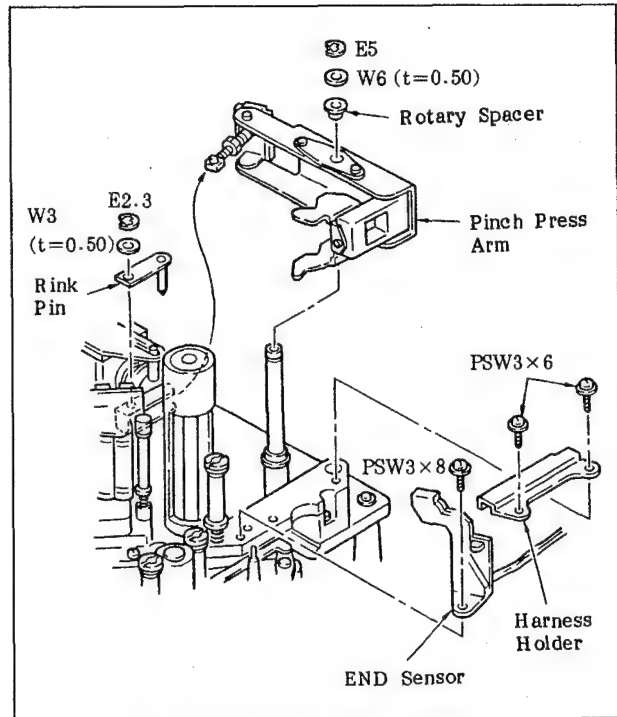

Fig. 6-78 Removal of the Parts

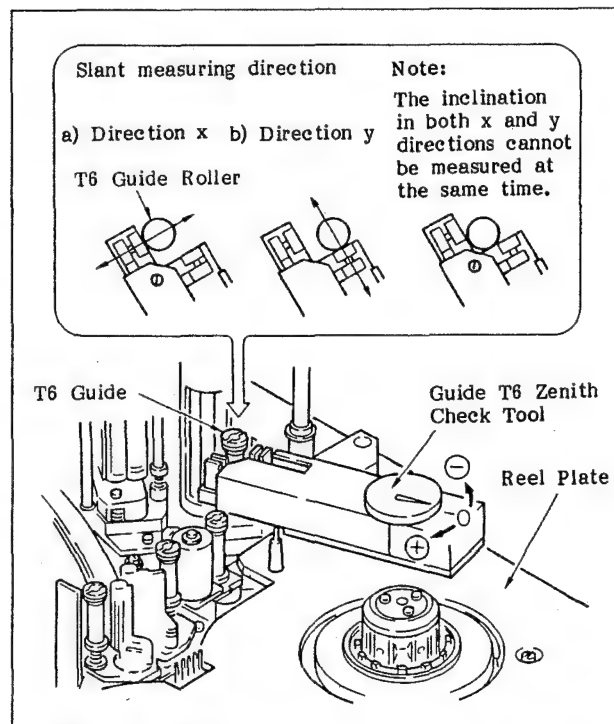

Fig. 6-79 Check the Inclination of the T6 Guide

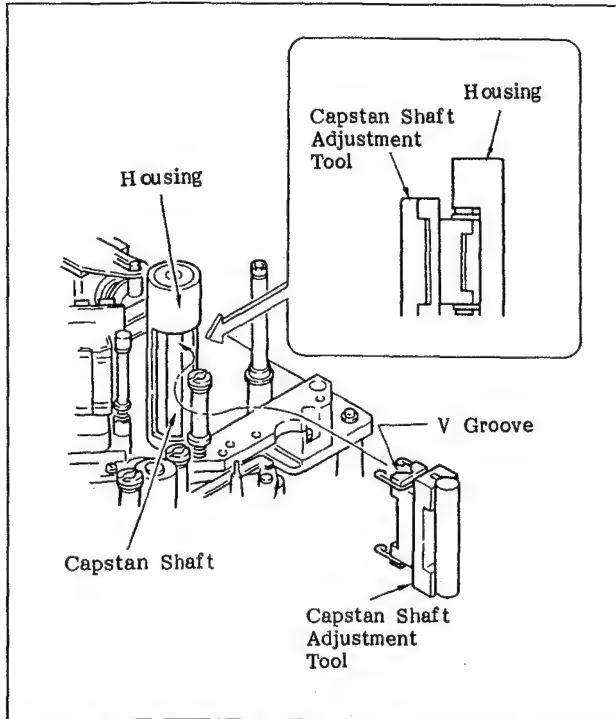

Fig. 6-80 Installing the Capstan Shaft Adjustment Tool

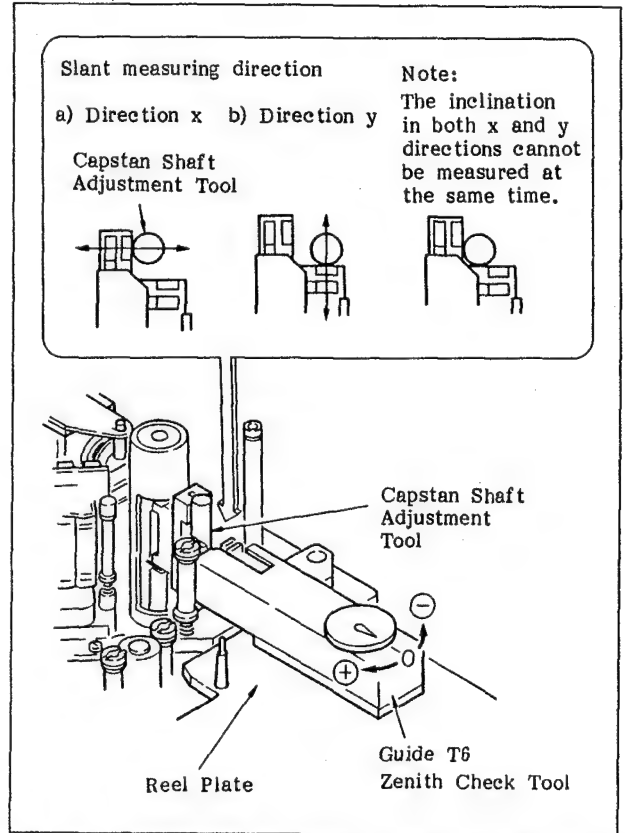
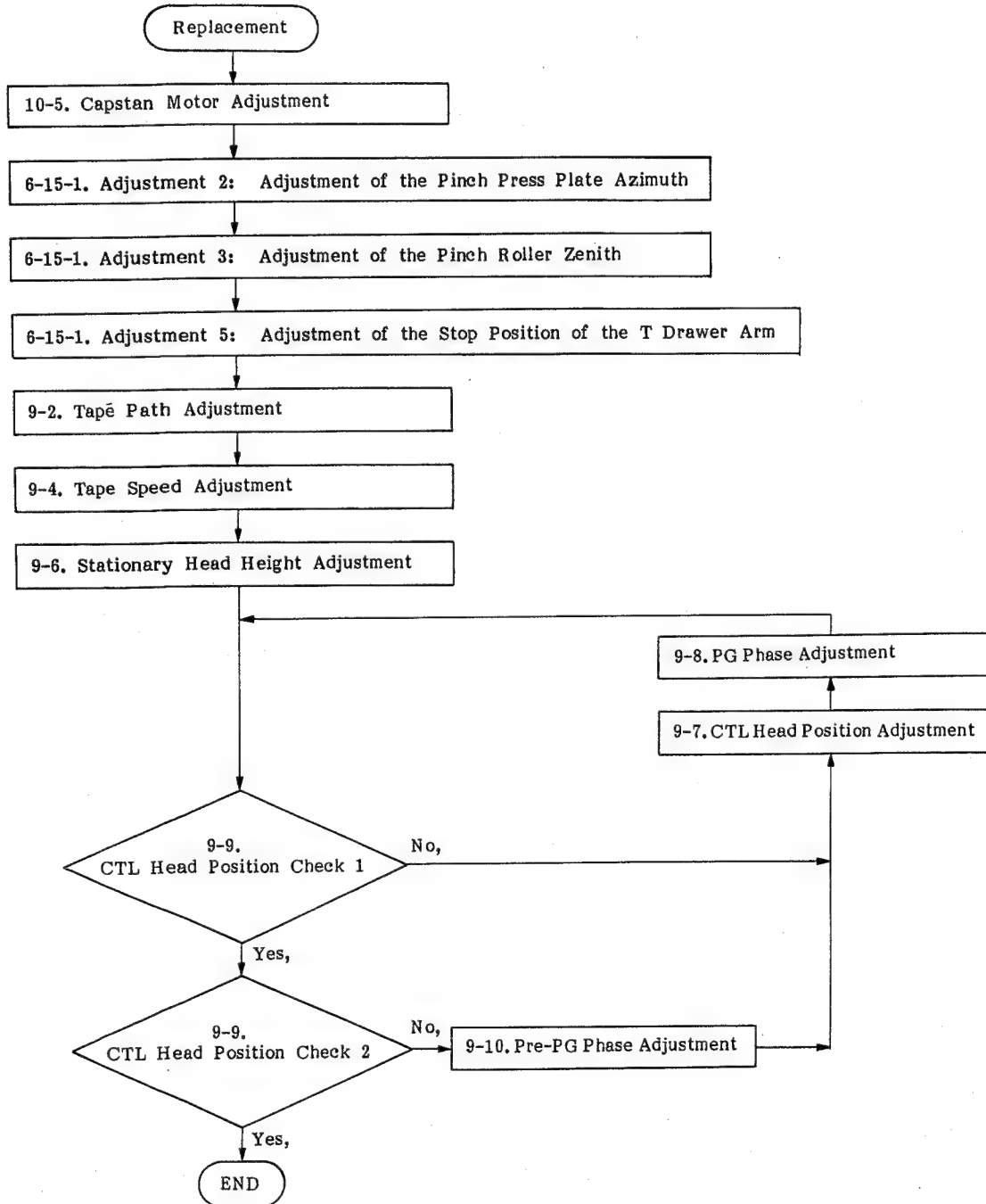

Fig. 6-81 Measuring the Deviation of the Capstan Shaft

6-14-2. Adjustment to be Made after Replacing the Capstan Motor



6. PARTS REPLACEMENT AND ADJUSTMENT

6-15. PINCH ROLLER

6-15-1. Adjustments Made after Replacing the Mechanical Parts of the Pinch Roller

Adjustment 1. Adjustments of the Inclination and the Height of the T5 Guide

Background Knowledge

A. Use the following tools for making the adjustments.

Reel Plate: J-6251-170-A

Reel Table Height Adjustment Tool: J-6252-190-A

Guide S5 Zenith Check Tool: J-6252-360-A

Slant Check Master: J-6252-730-A

B. Adjust the guide S5 zenith check tool before using it by referring to section 2-9.

Adjusting the Inclination

a. Remove the pinch press arm, END sensor, and harness holder by referring to Figure 6-82.

b. Rotate the threading motor manually to set it in threading condition.

c. Push the T5 guide in the direction of the arrow with your finger, as shown in Figure 6-83, and then insert a 4 to 6mm thickness spacer between the T drawer arm and the arm stopper.

Note: Use paper for the spacer.

d. Move the reel motor in the M cassette position and then set the reel plate.

e. Push the guide S5 zenith check tool against the T5 guide, as shown in Figure 6-84. Check that the inclinations in the x and y directions meet the following specifications.

Spec.: Direction x: 0 to +20 μ m

Direction y: \pm 20 μ m

If they do not, insert spacers in the positions shown in Figure 6-85 and then check again that the above specifications are met.

Spacer

| Thickness (μ m) | Part Number |
|----------------------|--------------|
| 10 | 3-715-319-01 |
| 20 | 3-715-319-11 |
| 30 | 3-715-319-21 |
| 50 | 3-715-319-31 |

- f. Remove the spacer that was inserted in step c.
- g. Rotate the threading motor manually to set it in unthreading condition.
- h. Replace the pinch press arm, END sensor, and harness holder, which were removed in step a, in their original positions.

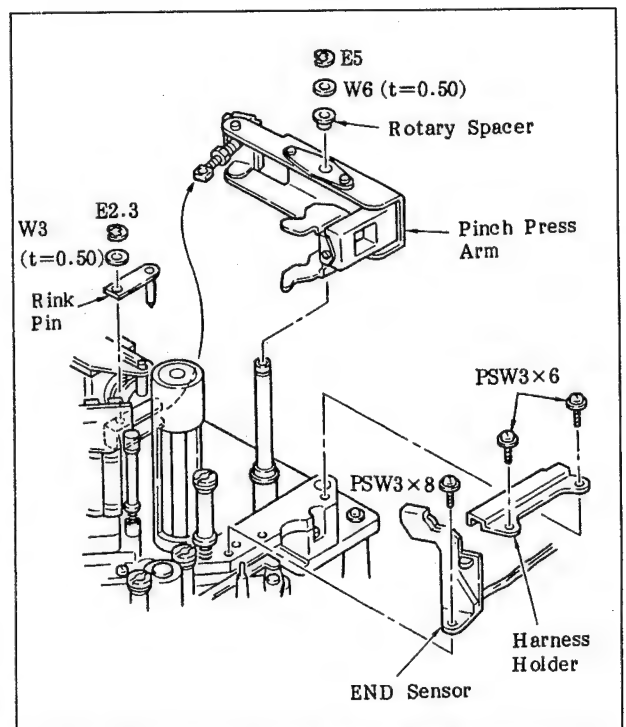

Fig. 6-82 Preparation before Making the Adjustments (1)

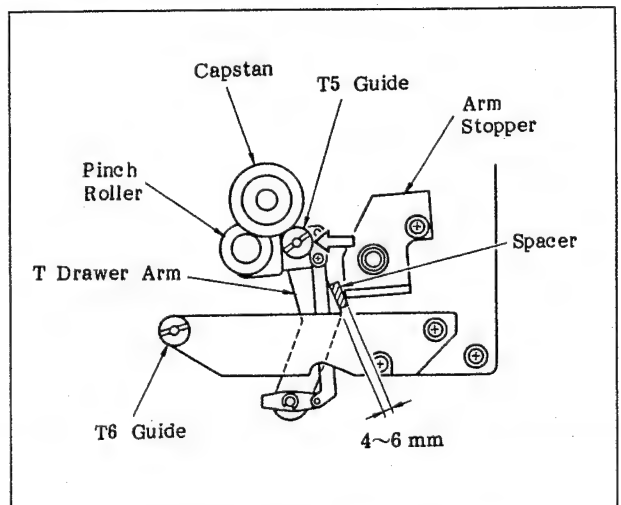

Fig. 6-83 Preparation before Making the Adjustments (2)



Adjusting the Height

- i. Push the reel table height adjustment tool against the T5 guide, as shown in Figure 6-86. Check that the reel table height adjustment tool touches the lower flange.
- If it does not, loosen the set screw of the T5 guide shown in Figure 6-84, and then adjust the height of the lower flange by rotating the flange holder.
- j. Tighten the set screw and then check it again in step i.

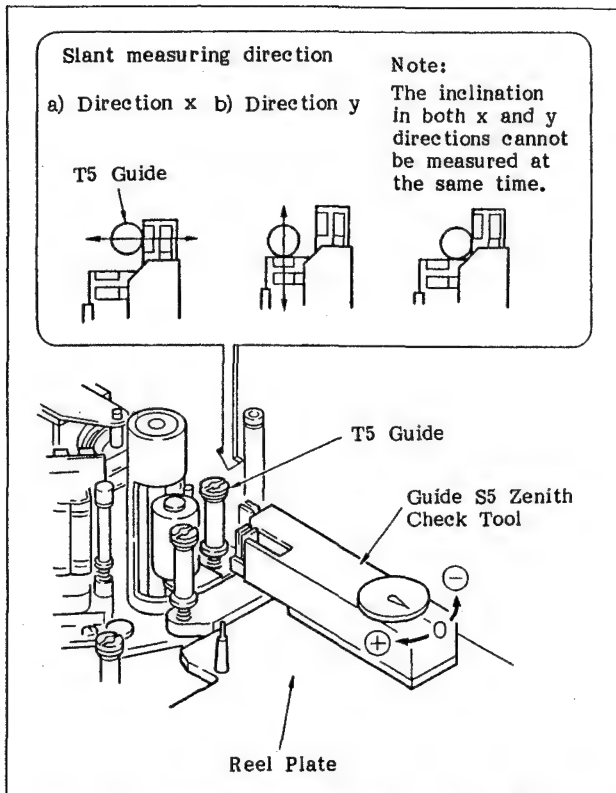

Fig. 6-84 Checking the Inclination of the T5 Guide

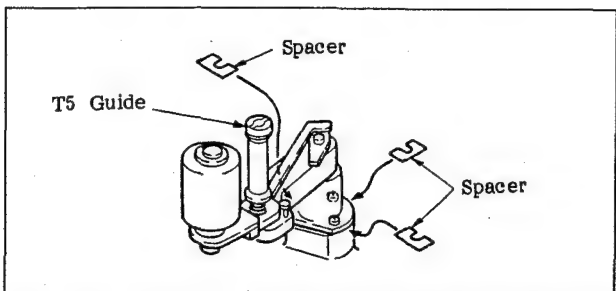

Fig. 6-85 Adjustment of the Inclination of the T5 Guide

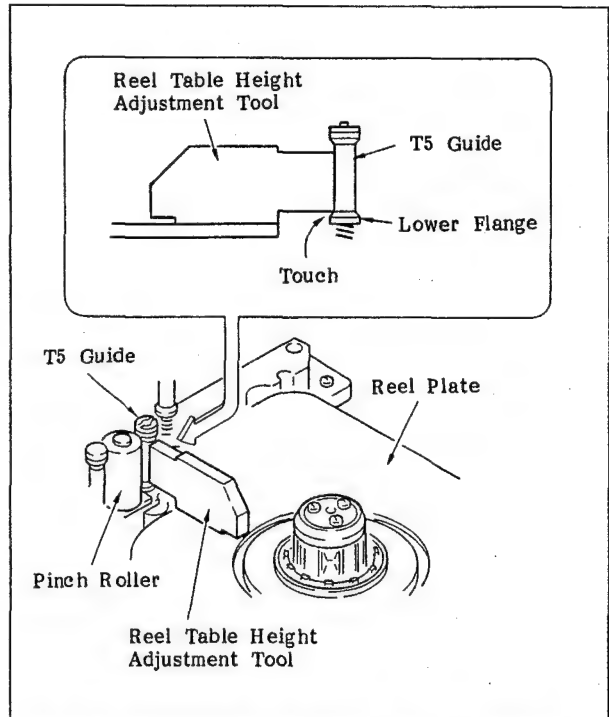

Fig. 6-86 Checking the Height of the T5 Guide

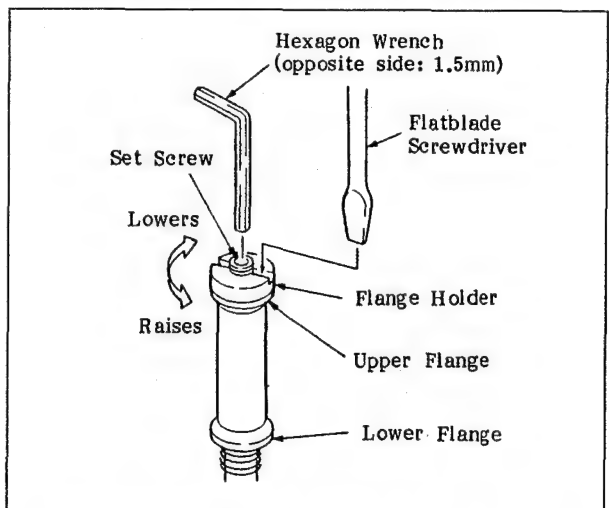

Fig. 6-87 Adjusting the Height of the T5 Guide

Adjustment 2. Adjustment of the Pinch Press Plate Azimuth

Use the following tool for making the adjustment.

Pinch Roller Check Tool: J-6251-850-A

- a. Attach the Pinch roller check tool to the capstan, as shown in Figure 6-88.

Note: Do not move the tool up and down after it has been attached to the capstan.

- b. Check that the two lamps of the pinch roller check tool light at the same time. When they do, go to step d. If they do not, make the following adjustment.
 - c. Loosen one of the two screws that hold the arm adjustment plate shown in Figure 6-88. Make the adjustment by inserting a flat blade screw driver into the square hole shown in the figure and rotating it. After completion of the adjustment, check again the pinch roller plate azimuth in step b.
 - d. Set the pinch roller check tool in the position shown in Figure 6-89(1). Slide the tool in the direction of the black arrow while slightly pressing the pinch solenoid. Make a note of how the lights work at this time. (For instance, "the red lamp lights, and then the green lamp lights.")
 - e. Set the pinch roller check tool in the position shown in Figure 6-89(2). Slide the tool in the direction of the black arrow while slightly pressing the pinch solenoid. Check that the lamps light in the reverse order of step d. When they do, go to step g. If they do not, make the following adjustment.
 - f. Make the adjustment by inserting a flat blade screwdriver into the square hole shown in Figure 6-88 and by rotating it a little. After completing the adjustment, repeat the procedure from step d.
 - g. If the two screws that hold the arm adjustment plate have been loosened, tighten them firmly and then perform the checks of steps d and e.
 - h. When the two screws that attach the arm adjustment plate have been loosened, apply glue to the head of the screws.
 - i. Remove the pinch roller check tool that was attached to the capstan.
- Note: Be sure not to move the tool up and down when removing it.**

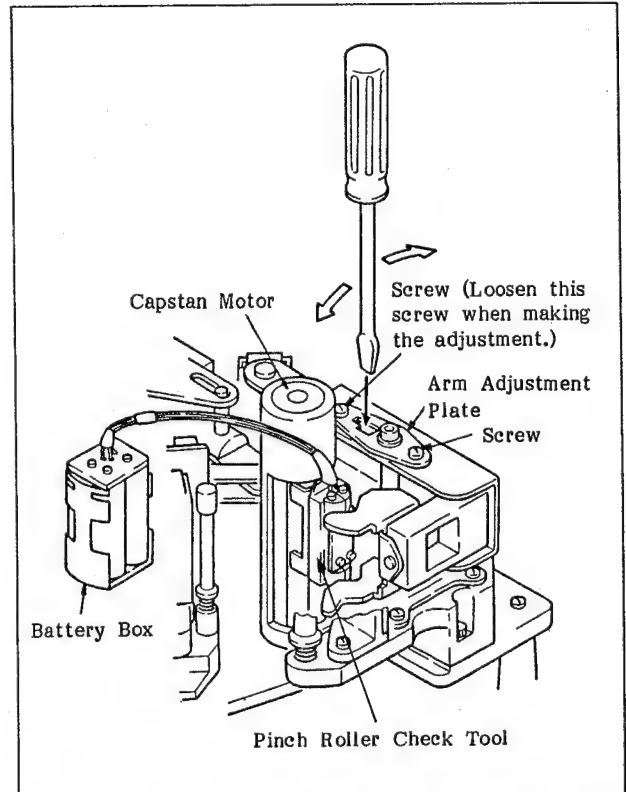

Fig. 6-88 Fine Adjustment of the Pinch Roller Plate Azimuth

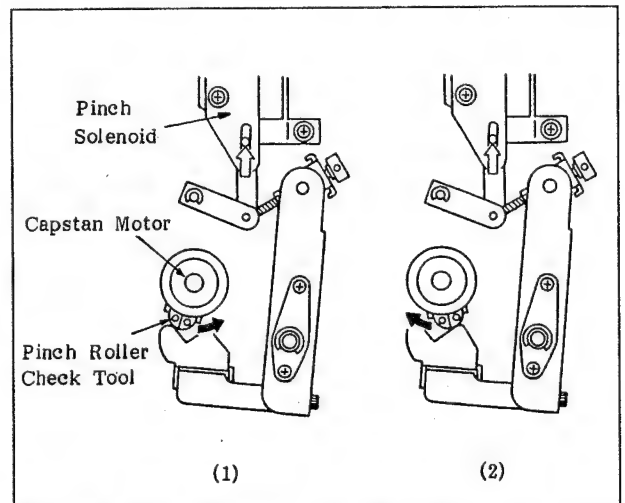

Fig. 6-89 Fine Adjustment of the Pinch Roller Plate Azimuth



Adjustment 3. Adjustment of the Pinch Roller Zenith

- a. Turn the power on. Then, press the **TEST**, **F3** (CHECKER), and **F1** (CONTINUE) keys on the control panel in that order to set the machine in CHECKER mode.
- b. Press the **F3** (C), **4**, **SET**, **F6** (F), **2**, **SET**, and **<** keys on the control panel in that order to set the machine in the threading status without loading the cassette tape.
- c. Press the **F6** (F), **3**, and **TEST** keys on the control panel in that order. Then press the **<** + **>** keys to push the pinch roller against the capstan once and then to separate them.
- d. Bring the pinch roller close to the capstan slowly by pushing the pinch solenoid by a hand. Check that the inclination of the pinch roller and the capstan meets the specification shown in Figure 6-90 when the pinch roller starts to rotate. When they do, go to step k. If they do not, make the following adjustments.
- e. Press the **F6** (F), **2**, **SET** and **>** keys on the control panel in that order to set the T arm in approximately a half-threading condition.
- f. Remove the set screws (C2x5) that hold the PS guide assembly and move the assembly in the direction of the arrow, as shown in the figure. (Figure 6-91)
If the PS guide assembly cannot be moved, turn the flange holder counterclockwise to move up the T5 guide.
- g. Loosen the three set screws that hold the pinch support plate, shown in Figure 6-92. Insert spacer(s) of the appropriate thickness, shown in the following table, between the pinch support plate and the pinch block. Then tighten the three set screws.

Spacer

| Thickness (µm) | Part Number |
|----------------|--------------|
| 10 | 3-715-319-01 |
| 20 | 3-715-319-11 |
| 30 | 3-715-319-21 |
| 50 | 3-715-319-31 |

- h. Return the PS guide assembly to its original position and fasten it slightly with the set screws.
- i. Press the **<** key on the control panel to set it in threading condition. Then check the zenith of the pinch roller by performing steps c and d.

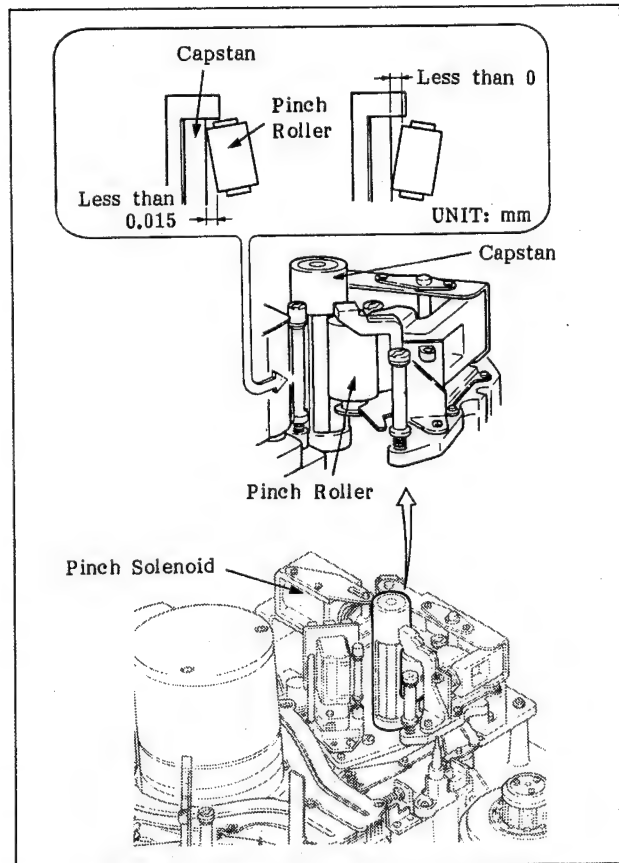

Fig. 6-90 Check the Pinch Roller Zenith

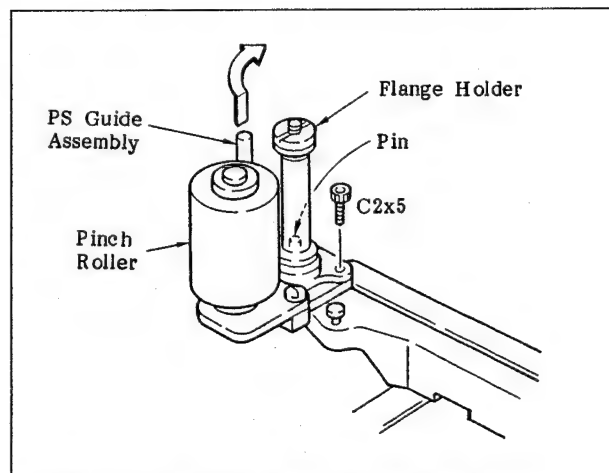

Fig. 6-91 Movement of the PS Guide Assembly

- j. Press the **F6** (F), **2**, and **SET** keys on the control panel to set the T arm in approximately a half threading status.
- k. When the three screws that hold the pinch support plate have been loosened for making the adjustment, apply retaining compound to the heads of the three screws.
- l. Tighten the set screws that temporarily fasten the PS guide assembly securely.
- m. Perform Adjustment 1, "Adjustment of the inclination and the Height of the T5 Guide," when the flange holder of the T5 guide is moved in step f.

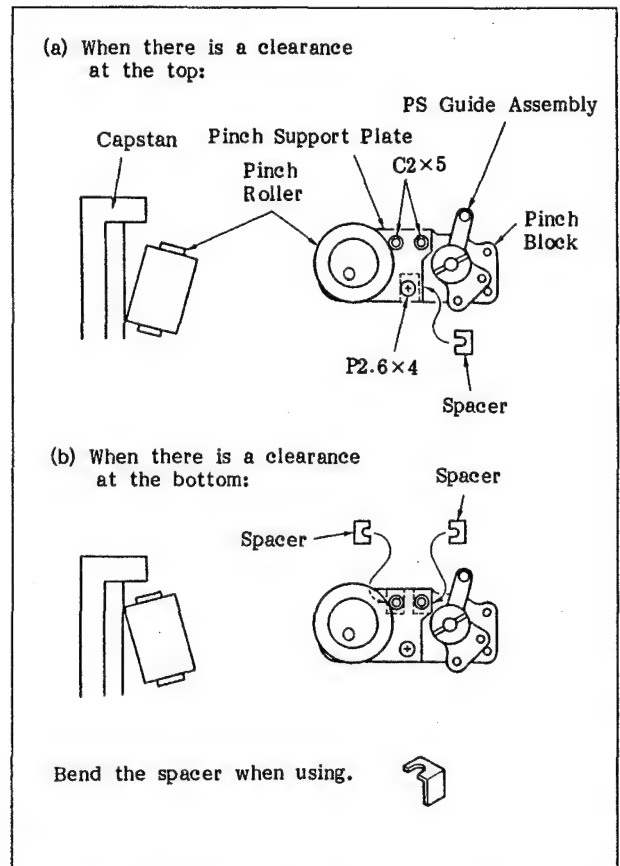

Fig. 6-92 Adjustment of the Tilting of the Pinch Roller

Adjustment 4. Adjustment of the Pinch Roller Azimuth

Use the following tools for making the adjustment.

Reel Plate: J-6251-170-B

Reel Table Height Adjustment Tool: J-6252-190-A

Thickness Gauge: J-6041-670-A

- a. Remove the pinch press arm, END sensor, harness holder, and the connector (CN417) of the END sensor, by referring to Figure 6-93.
- b. Turn on the power of the machine. Press the **TEST**, **F3** (CHECKER) and **F1** (CONTINUE) keys on the control panel in that order to set the machine in checker mode.
- c. Press the **F3** (C), **4**, **SET**, **F6** (F), **0**, **SET** and **>** keys on the control panel in that order to set the reel motor in the M cassette position.
- d. Set the reel plate.
- e. Press the **F6** (F), **2**, **SET** and **<** keys on the control panel in that order to set it in threading condition without loading a cassette tape.
- f. Place the reel table height adjustment tool against the pinch roller, as shown in Figure 6-94. In case there is no gap at the top nor bottom as shown in Fig. A, azimuth adjustment is unnecessary. So move on to the step 0. If there is a gap at either top or bottom, however, azimuth adjustment is required. So implement the following procedures.

Note: Support the reel table height adjustment tool with your fingers because it is not set firmly.
- g. Press the **>** key on the control panel to set it in approximately a half-threading condition.
- h. Remove the screws (C2x5) that hold the PS guide assembly and then move the PS guide assembly in the direction of the arrow. (Figure 6-95)
If the PS guide assembly does not move, rotate the flange holder counterclockwise to move up the T5 guide.
- i. Loosen the three screws that hold the pinch support plate, shown in Figure 6-96. Then, insert the appropriate thickness of the spacer, shown below, between the pinch support plate and the pinch block and tighten the three screws firmly.

Spacer

| Thickness (μm) | Part Number |
|----------------|--------------|
| 10 | 3-715-319-01 |
| 20 | 3-715-319-11 |
| 30 | 3-715-319-21 |
| 50 | 3-715-319-31 |

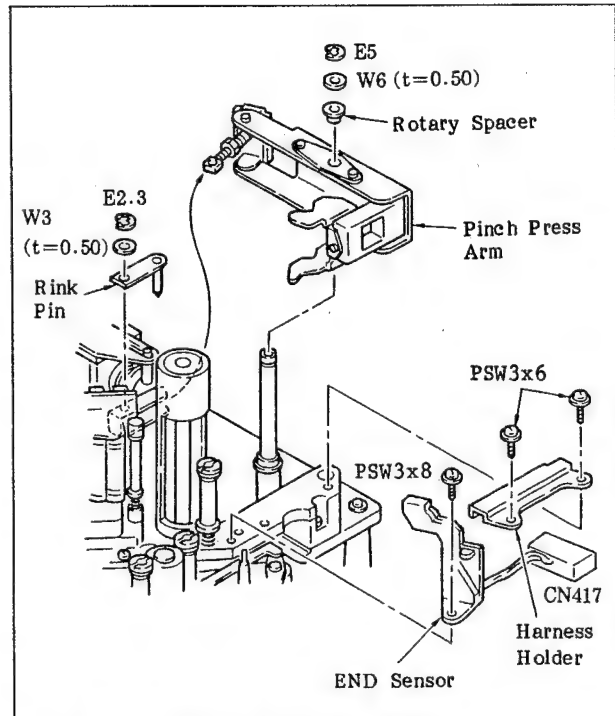

Fig. 6-93 Preparation before Making the Adjustments

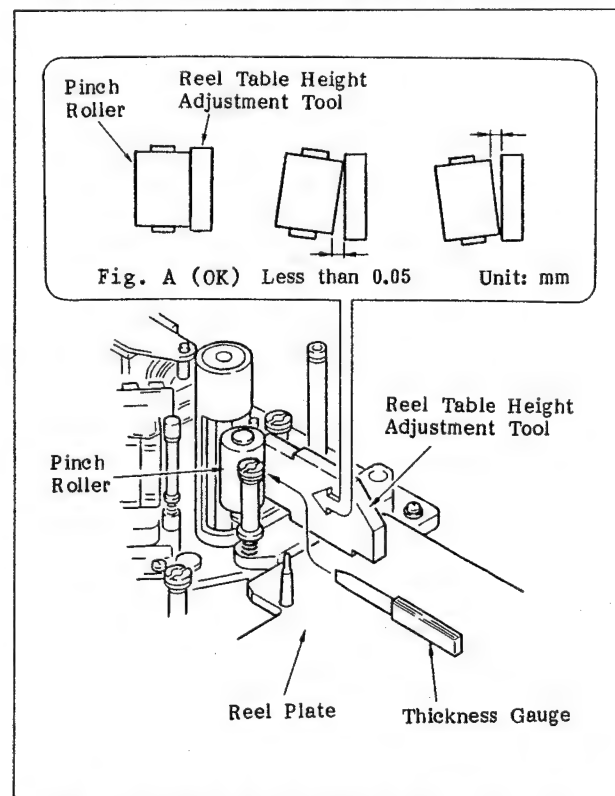





Fig. 6-94 Check of the Azimuth of the Pinch Roller

- j. Return the PS guide to its original position and then fasten it slightly with the set screws.
- k. Press the  key on the control panel to set it in threading condition. Perform step f and then check the azimuth of the pinch roller again.
- l. Press the  key on the control panel to set it in approximately a half unthreading condition.
- m. When the three screws that hold the pinch support plate have been loosened for making the adjustment, apply glue to the heads of the three screws.
- n. Tighten the set screws that fasten the PS guide assembly temporarily.
- o. Press the  key on the control panel to set it in unthreading END condition.
- p. If the flange holder of the T5 guide was moved in step h, perform Adjustment 1, "Adjustment of the inclination and the Height of the T5 Guide".
- q. Return the pinch press arm, END sensor, harness holder, and the connector (CN417) of the END sensor that was removed in step a to their original position.

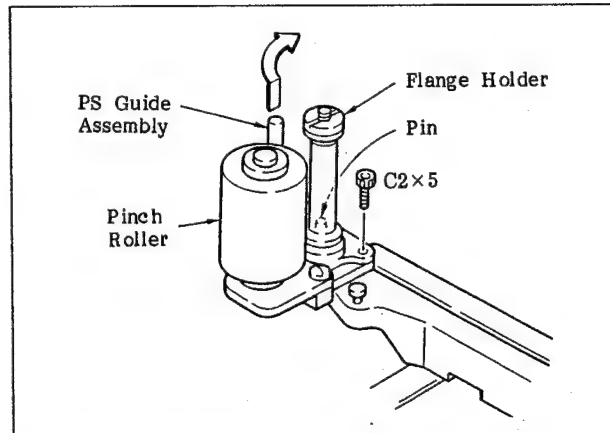

Fig. 6-95 Movement of the PS Guide Assembly

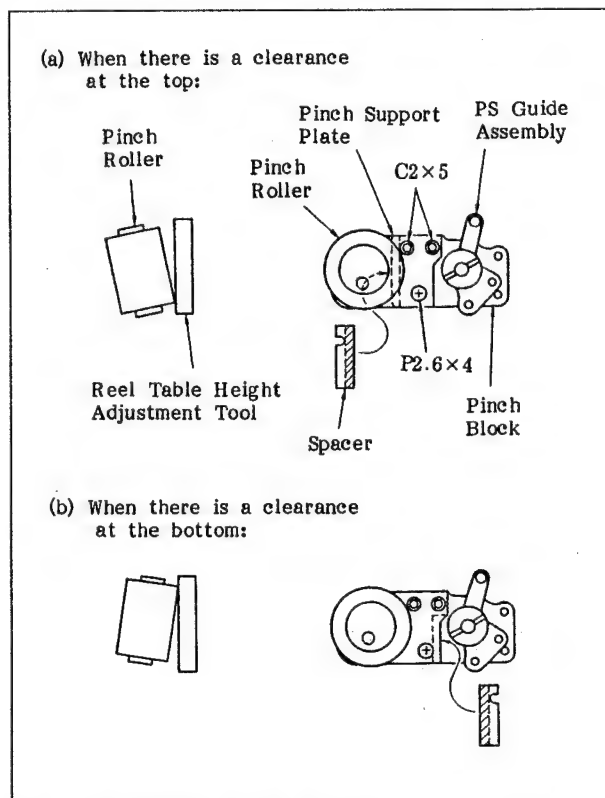

Fig. 6-96 Adjustment of the Azimuth of the Pinch Roller



Adjustment 5. Adjustment of the Stop Position of the T Drawer Arm

- a. Turn the power on. Then, press the **TEST**, **F3** (CHECKER), and **F1** (CONTINUE) keys on the control panel in that order to set the machine in CHECKER mode.
- b. Press the **F3** (C), **4**, **SET**, **F6** (F), **2**, **SET**, and **<** keys on the control panel in that order to set the machine in the threading status without loading the cassette tape.
- c. Loosen the screw that holds the arm stopper.
- d. Push up the pinch solenoid so that the pinch roller fits against the capstan. Bring the arm stopper into contact with the T drawer arm in this condition, and then tighten the screw that holds the arm stopper firmly.
- e. Check that the rotary link does not move when the pinch solenoid is pushed up several times. If it does, repeat the procedure from step c.
- f. Apply glue to the screw that holds the arm stopper.
- g. Press the **F6** (F), **2**, **SET**, and **<** keys on the control panel in that order to set it in the unthreading status.
- h. Perform step b again to set it in threading condition.
- i. Check that the S drawer block pin touches the retainer block and the T drawer arm touches the arm stopper at the same time, as shown in Figure 6-98. If they do not, loosen the two screws that hold the rotary link on the T drawer arm side and adjust the position of the rotary link.
- j. Press the **F12** (EXIT) key on the control panel to terminate the checker mode.

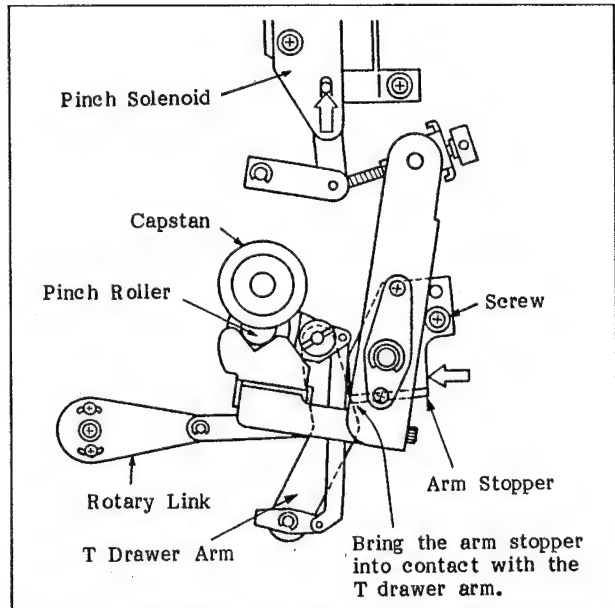

Fig. 6-97 Adjustment of the Stop Position of the T Drawer Arm

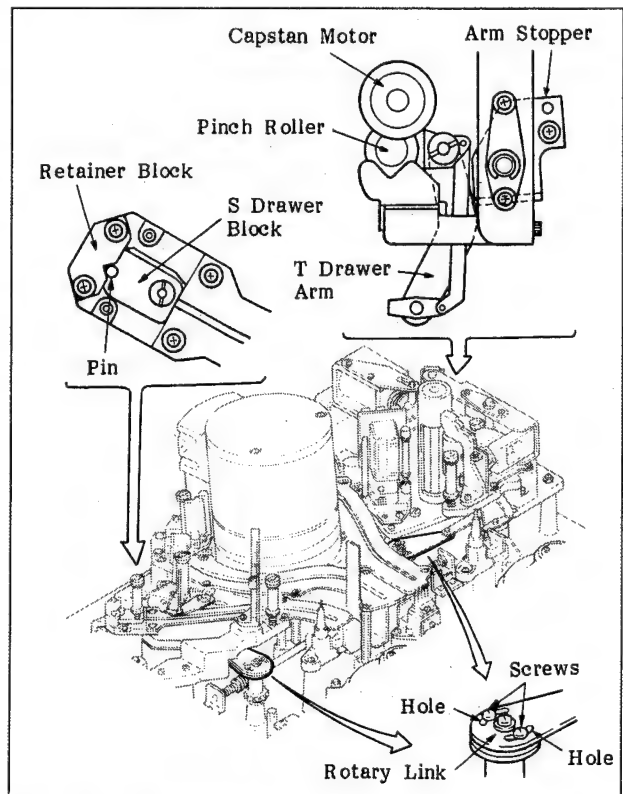

Fig. 6-98 Adjustment of the Position of the Rotary Link

Adjustment 6. Adjustment of the Pinch Roller Pressure

Use the following tool for making the adjustment.

Pinch Roller Adjustment Tool: J-6251-210-A

- a. Turn the power on. Then, press the **TEST**, **F3**-(CHECKER), and **F1**(CONTINUE) keys on the control panel in that order to set the machine in CHECKER mode.
- b. Press the **F3**(C), **4**, **SET**, **F6**(F), **2**, **SET**, and **<** keys on the control panel in that order to set the machine in the threading status without loading the cassette tape.
- c. Press the **F6**(F), **3**, and **SET** keys on the control panel in that order, then press the **<** and **>** keys or **F3** key to push the pinch roller against the capstan.

- d. Check that there is a 0.2mm to 0.4mm clearance between the press link and the press limiter, as shown in Figure 6-99. If there is, go to step f. If there is not, make the following adjustments.
- e. Loosen the set screw that holds the press limiter and adjust the limiter so that there is a clearance between it and the press arm link. After completion of the adjustment, tighten the set screw. Then, check the clearance in step d again.

Note: Tighten the set screw with a torque of 7 to 10kg-cm.

- f. Set the pinch roller adjustment tool as shown in Figure 6-93.
- g. Push the pinch roller adjustment tool in the direction of the arrow shown in the figure to separate the pinch roller from the capstan. Wait until the pinch roller stops rotating. Then, bring the pinch roller close to the capstan again. Read the value of the torque when the pinch roller starts to rotate again. Check that the value of the torque is equal to the following specification. If it is, go to step i. If it is not, make the following adjustment.

Spec.: 4.5 ± 0.5 kg-cm

- h. Adjust the value of the torque with the stopper nut shown in Figure 6-99. Then, repeat step g.
- i. Remove the adjustment tool and press the **F6**(F), **2**, **SET**, and **>** keys in that order to set the machine in the unthreading status.
- j. Press the **F12**(EXIT) key on the control panel to terminate.

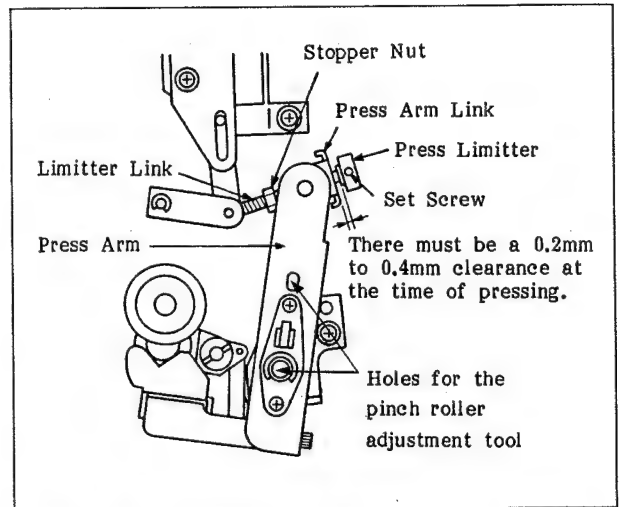

Fig. 6-99 Adjustment of the Pinch Roller Pressure

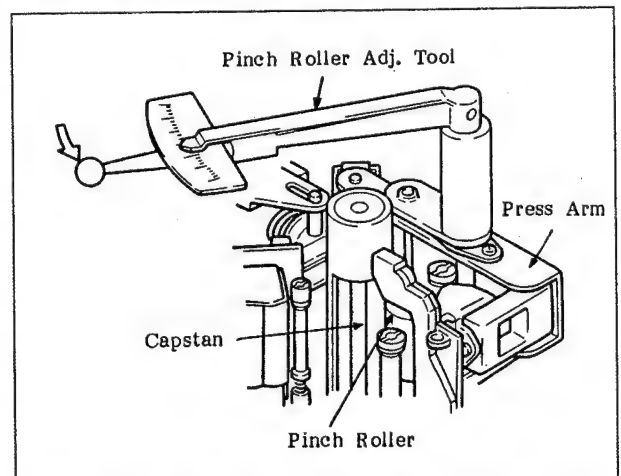

Fig. 6-100 Measurement of the Pinch Roller Pressure



Adjustment 7. Adjustment of the Pinch Press Limiter

- a. Turn the power on. Then, press the **TEST**, **F3** (CHECKER), and **F1** (CONTINUE) keys on the control panel in that order to set the machine in CHECKER mode.
- b. Press the **F3** (C), **4**, **SET**, **F6** (F), **2**, **SET**, and **<** keys on the control panel in that order to set the machine in the threading status without loading the cassette tape.
- c. Press the **F6** (F), **3**, and **SET** keys on the control panel in that order.
- d. Press the **<** + **>** keys on the control panel to push the pinch roller onto the capstan.
- e. Check that the clearance between the press limiter and the press arm link is 0.2 to 0.4 mm. If it is, go to step g. If it is not, make the following adjustment.
- f. Press the **<** key on the control panel to separate the pinch roller from the capstan. Loosen the set screw (3x4) that holds the press limiter. Adjust the position of the press limiter. Tighten the set screw and then perform steps d and e again.
- g. Press the **<** + **>** keys on the control panel. Perform step e again to check the clearance. If it is satisfied, go to the next step.
- h. Press the **F6** (F), **2** and **SET** keys on the control panel in that order. Check that the pinch press plate does not touch the flange when the threading and unthreading conditions are repeated by pressing the **>** and **<** keys.
- i. Press the **>** key on the control panel to set it in the unthreading status.
- j. Press the **F12** key on the control panel to terminate the CHECKER mode.

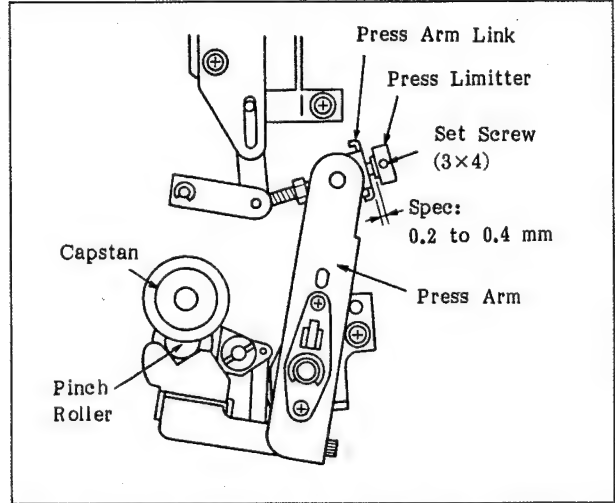

Fig. 6-101 Adjustment of the Pinch Press Limiter

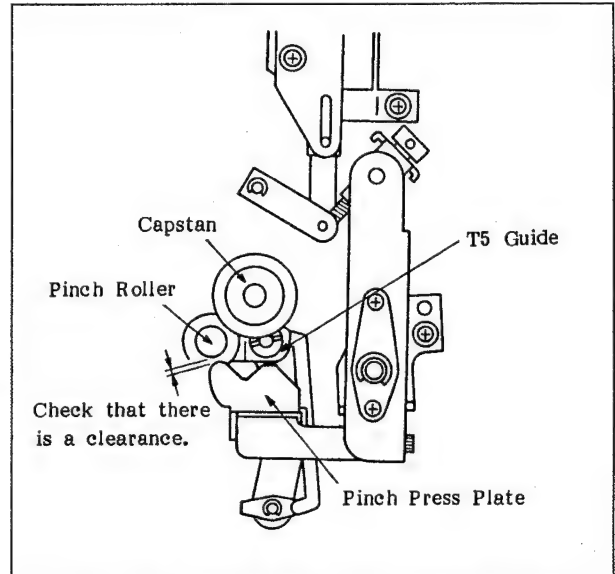

Fig. 6-102 Check of the Pinch Solenoid Stroke

6-15-2. Replacement of the Pinch Roller

1. Remove the pinch roller, replace it with a new one, and attach it again by referring to Figure 6-103.
2. Make the following adjustments.

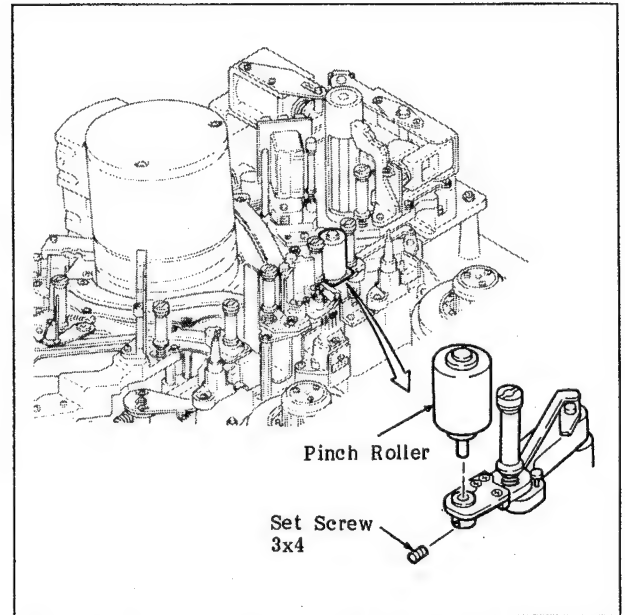
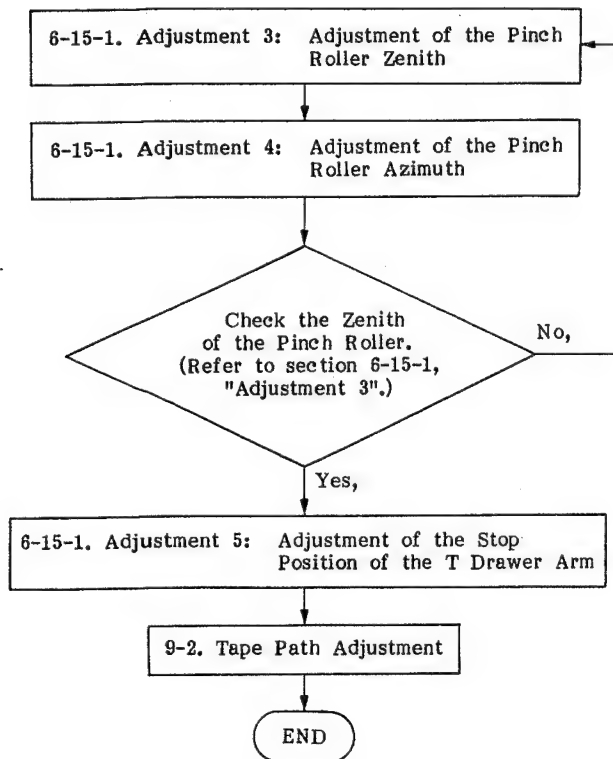

Fig. 6-103 Replacement of the Pinch Roller

6-15-3. Replacement of the Pinch Block

1. Remove the pinch block by referring to Figure 6-104.
 2. Replace the pinch block with a new one and attach it again.
- Note:** Be careful of the direction for attaching the torsion spring.
3. Push the pinch roller in the direction of the arrow shown in Figure 6-105. Check that the pinch roller returns to its original position when it is released.
 4. Make the following adjustments.

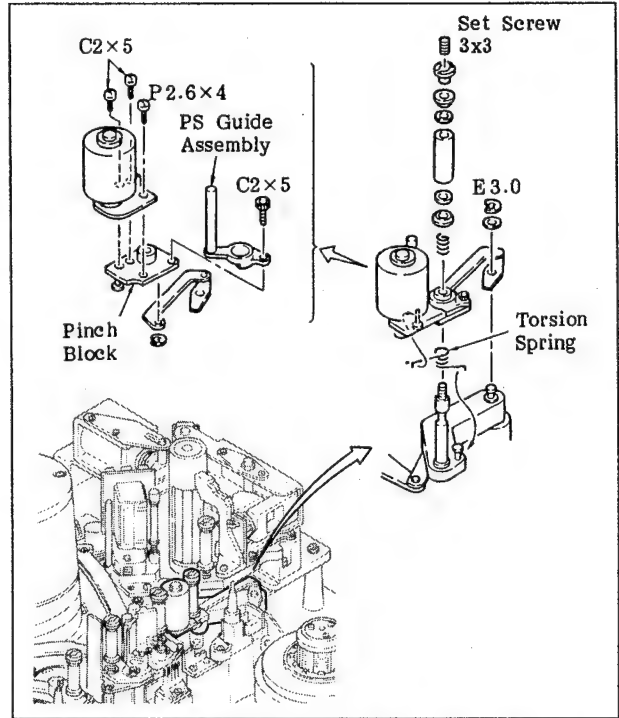
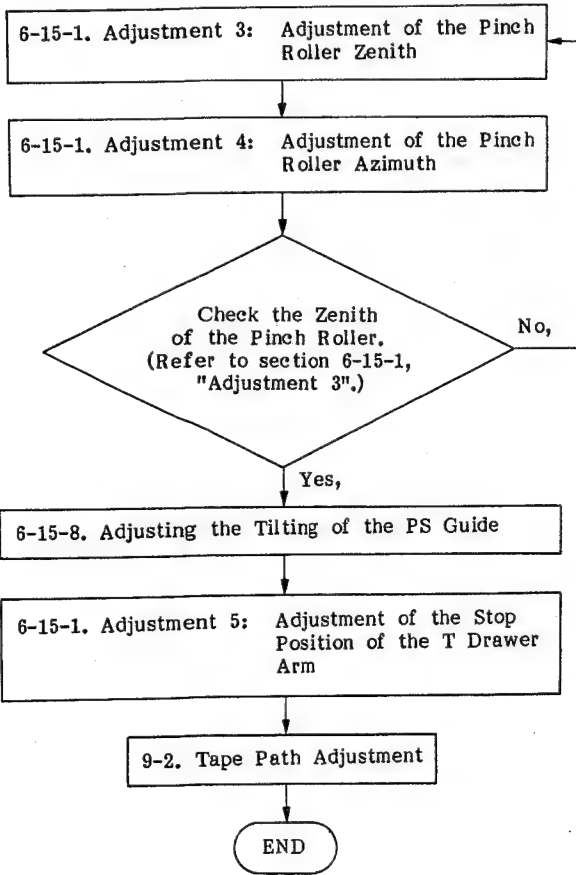

Fig. 6-104 Replacement of the Pinch Block

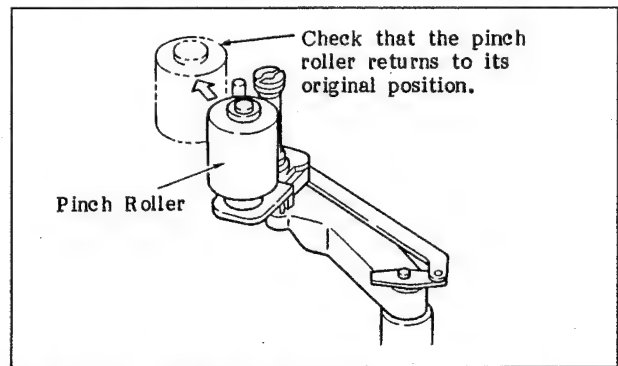

Fig. 6-105 Checking the Operation of the Pinch Roller

6-15-4. Replacement of the Components of the Pinch Roller

Background Knowledge

A. The following components may be replaced.

- . Press Block
- . Pinch Press Plate
- . Arm Adjustment Plate
- . Pinch Press Arm

B. Use the following tool.

- . Thickness Gauge: J-6041-670-A

1. Remove the pinch press arm assembly by referring to Figure 6-106.
2. Remove the component that needs to be replaced and replace it with a new one by referring to Figure 6-107.

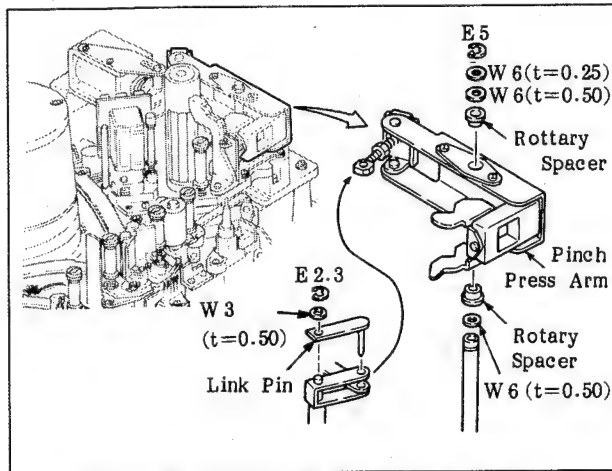

Fig. 6-106 Removal of the Pinch Press Arm

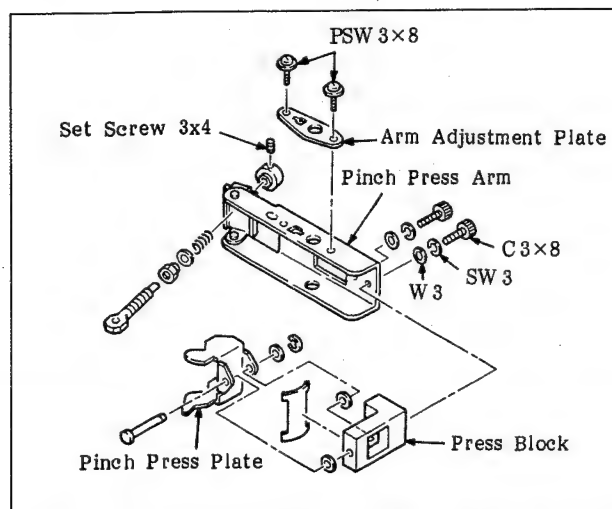

Fig. 6-107 Replacement of the Components of the Pinch Roller

Adjustment of the Position of the Pinch Press Plate

Note: Make the following adjustments when the pinch press plate or the press block has been replaced.

3. Measure clearance d with a thickness gauge when the pinch press plate is pushed against the press block without inserting a spacer between them as shown in the sectional drawing of Figure 6-108.

Determine the thickness of spacers (1), (2), and (3) by using the table according to the value of clearance d . Then, assemble the pinch press plate and the press block.

Spacer

| Thickness (mm) | Part Number |
|----------------|--------------|
| 0.13 | 3-701-439-01 |
| 0.25 | 3-701-439-11 |

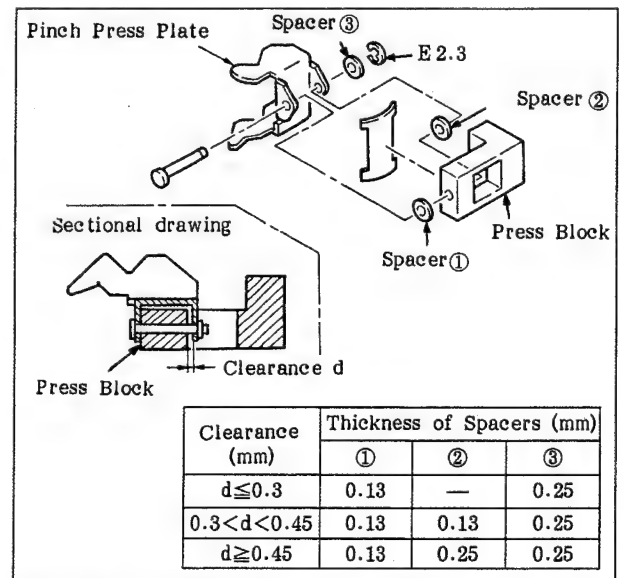

Fig. 6-108 Adjustment of the Position of the Pinch Press Plate

Adjustment of the Position for Assembling the Press Block

Note: Make the following adjustments when the pinch press arm has been removed from the press block.

4. Adjust so that the parallelism of the end face of the pinch press arm and the surface of the press block is within 0.2 mm when assembled.
5. Attach the pinch press arm assembly to the machine by referring to Figure 6-106.
6. Make the following adjustments.

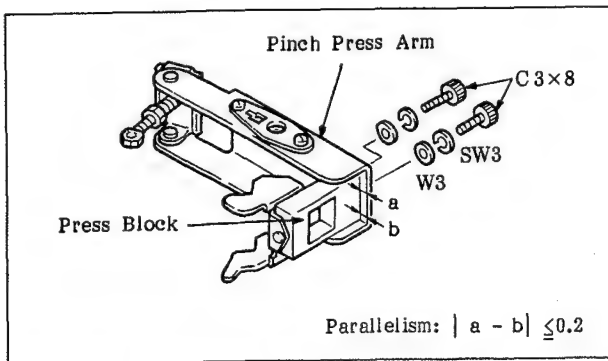
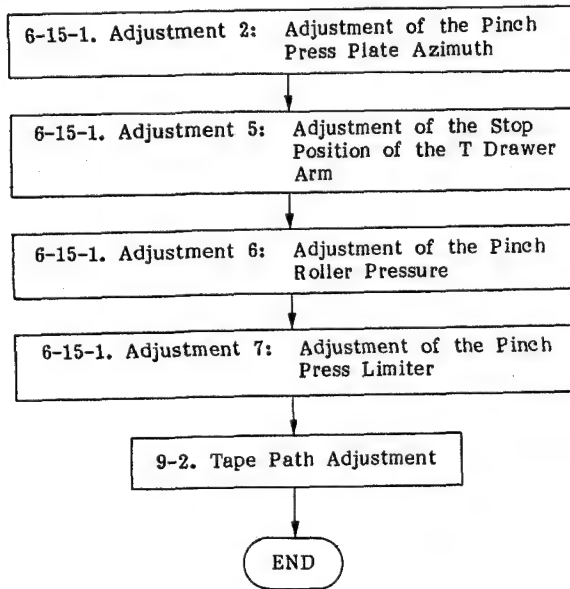

Fig. 6-109 Adjustment of the Position for Assembling the Press Block

6-15-5. Replacement of the Limiter Link

1. Remove the limiter link by referring to Figure 6-110.
2. Replace the limiter link with a new one and attach it again.
3. Make the following adjustments.

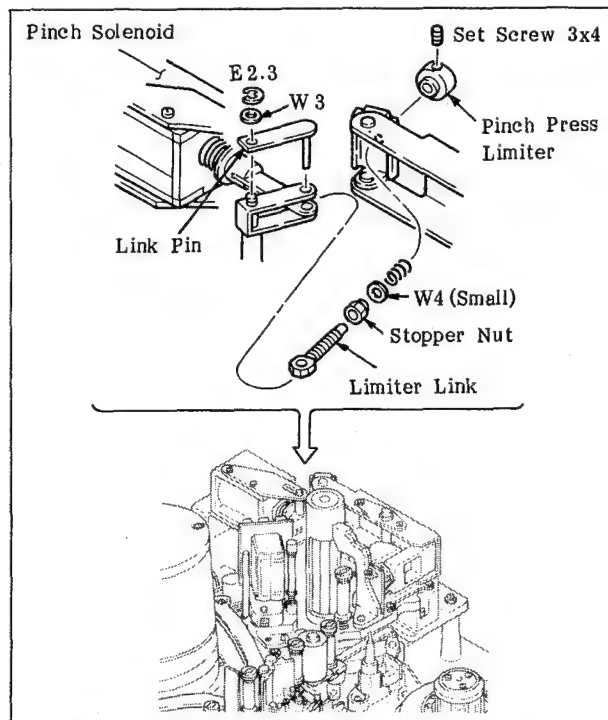
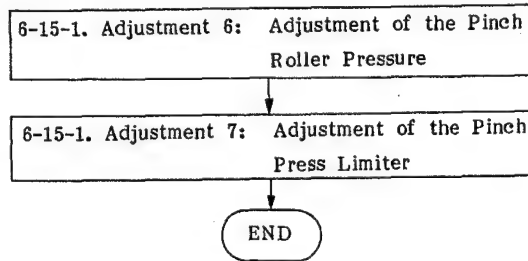

Fig. 6-110 Replacement of the Limiter Link

6-15-6. Replacement of the Arm Stopper

1. Remove the arm stopper by referring to Figure 6-111.
2. Replace the arm stopper with a new one and attach it again.
3. Make the following adjustments.

6-15-1. Adjustment 5: Adjustment of the Stop Position of the T Drawer Arm

END

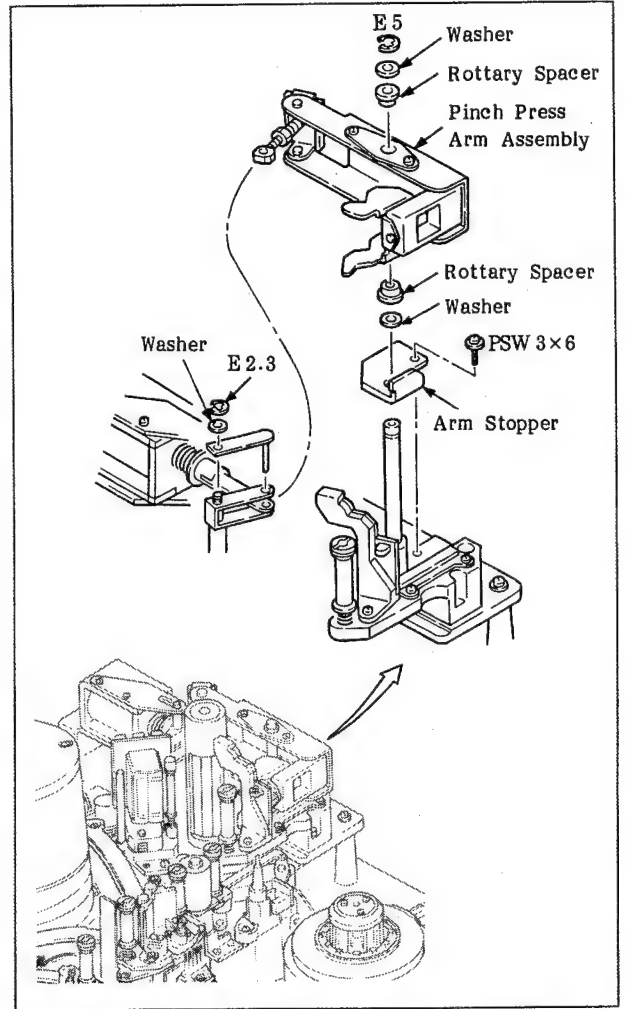

Fig. 6-111 Replacement of the Arm Stopper

6-15-7. Replacement of the Arm

1. Remove the arm assembly by referring to Figure 6-112.
2. Remove the arm from the arm assembly by referring to Figure 6-113.
3. Replace the arm with a new one and attach the removed components in the reverse order.
4. Make the following adjustments.

- | |
|---|
| 6-15-1. Adjustment 1: Adjustment of the Inclination of the T5 Guide |
| 6-15-1. Adjustment 3: Adjustment of the Pinch Roller Zenith |
| 6-15-1. Adjustment 4: Adjustment of the Pinch Roller Azimuth |
| 6-15-1. Adjustment 5: Adjustment of the Stop Position of the T Drawer Arm |

9-2. Tape Path Adjustment

END

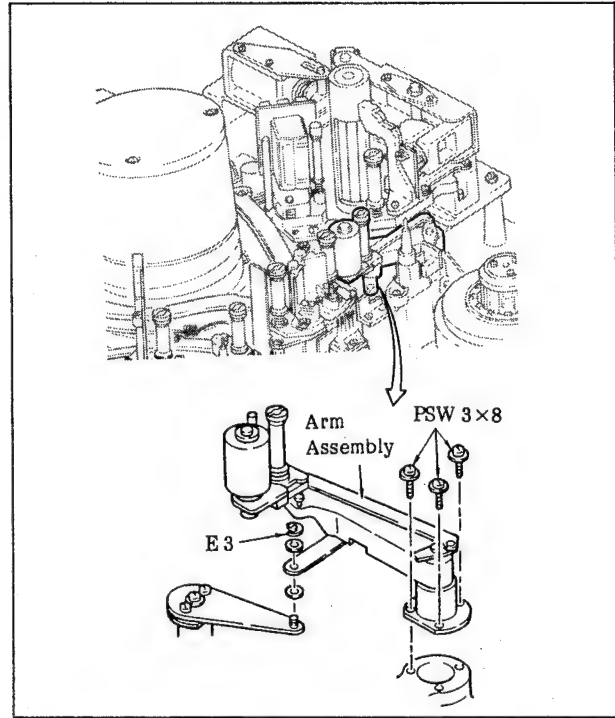

Fig. 6-112 Removing the Arm Assembly

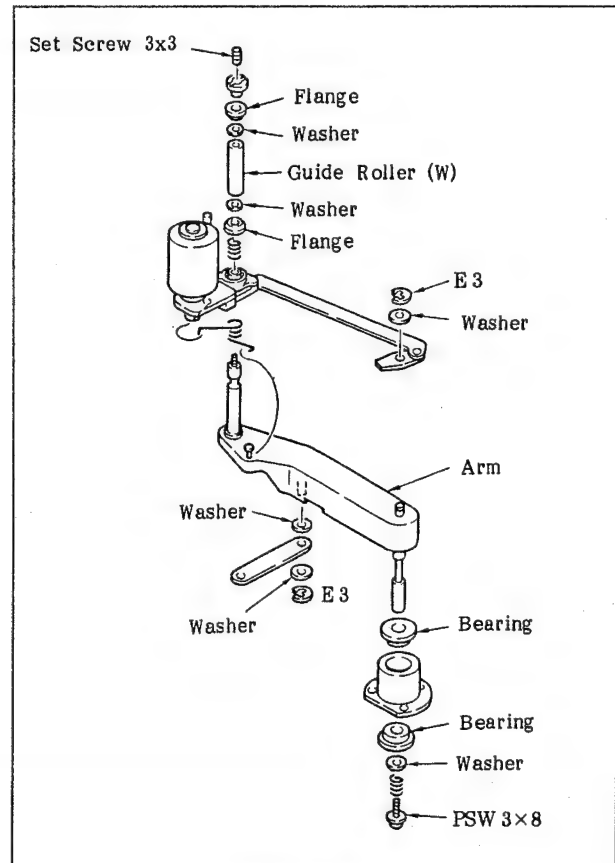

Fig. 6-113 Replacing the Arm

6-15-8. Replacement of the PS Guide Assembly

Background Knowledge

Use the following tools for making the adjustments after replacing the parts.

Reel Plate: J-6251-170-B

Reel Table Height Adjustment Tool: J-6252-190-A

S Plate Tool: J-6252-200-A

Replacement

1. Remove the PS guide assembly by referring to Figure 6-114.
2. Replace the PS guide assembly with a new one when installing. Turn it clockwise to remove the play, and then tighten it.

Note: Tighten the set screw with a torque of 3.5kg-cm.

Adjustment of the Tilting of the PS Guide

3. Place the S plate tool against the T5 guide, as shown in Figure 6-115, and make sure that any gap, which may occur at the top or bottom between the guide and the tool, is less than 100 μ m. If it is not, adjust it by pushing the top edge of the PS guide to bend the arm section.

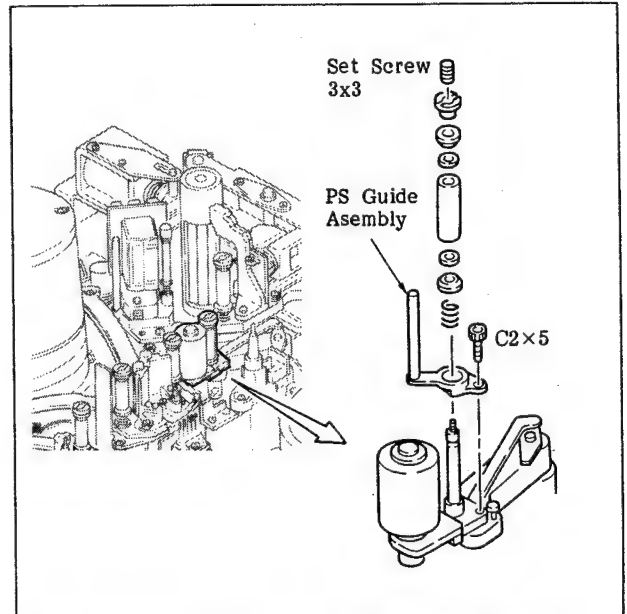

Fig. 6-114 Replacement of the PS Guide Assembly

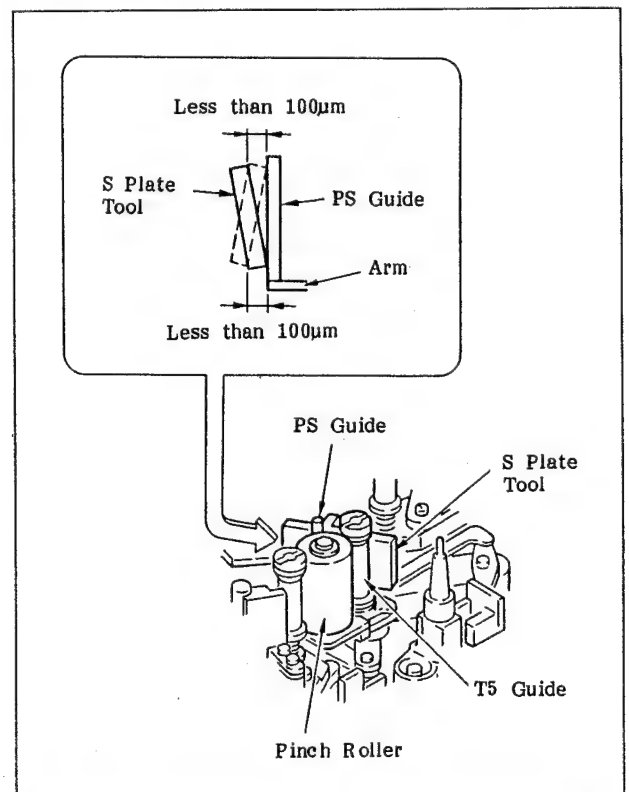

Fig. 6-115 Adjustment of the Tilting of the PS Guide

Adjustment of the Position of the PS Guide Assembly

4. Turn on the power of the machine. Press the **TEST**, **F3** (CHECKER) and **F1** (CONTINUE) keys on the control panel in that order to set the machine in checker mode.
5. Press the **F3** (C), **4**, **SET**, **F6** (F), **2**, **SET** and **<** keys on the control panel in that order to set it in threading condition without loading a cassette tape.
6. Press the **F6** (F), **3** and **SET** keys on the control panel in that order.
7. Press the **+** **>** keys to push the pinch roller against the capstan.
8. Check that there is more than a 0.5mm clearance between the housing of the capstan motor and the PS guide. If there is, go to step 11. If there is not, perform the following steps.
9. Press the **<** key on the control panel to separate the pinch roller from the capstan.
10. Loosen the three set screws that hold the capstan motor and rotate the housing counterclockwise slightly, and then tighten the set screws. Check the clearance again by performing steps 7 and 8.

Note: Do not rotate the housing excessively. It may destroy the adjustment mode in step 17.
11. Press the **F6** (F), **2**, **SET** and **>** keys on the control panel in that order to set it in unthreading condition.
12. Adjust the height of the T5 guide according to section 6-15-1, "Adjustment 1".
13. Remove the reel plate.
14. Press the **=**, **0** and **SET** keys on the control panel in that order to set the machine in normal condition.
15. Set the M cassette in threading condition.
16. Check that the PS guide is in contact with the tape. (Figure 6-117)
17. Push the pinch solenoid by hand. Check that there is more than a 0.5mm clearance between the housing of the capstan motor and the tape. (Figure 6-117)
18. Perform section 9-2, "Tape Transportation Adjustment".

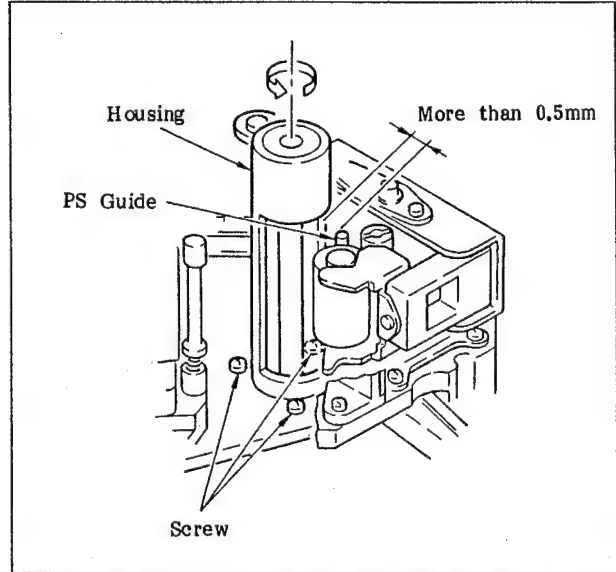

Fig. 6-116 Adjustment of the Position of the PS Guide Assembly (1)

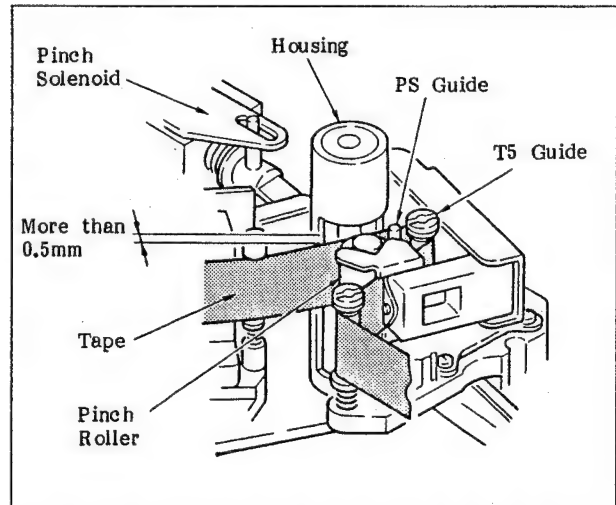

Fig. 6-117 Adjustment of the Position of the PS Guide Assembly (2)

6-15-9. Replacement of the T Roller Base

Background Knowledge

A. This procedure can also be used for replacing the T guide base assembly.

B. Use the following tools for making the adjustments.

Reel Plate: J-6251-170-B

Guide T6 Zenith Check Tool: J-6252-370-A

Slant Check Master: J-6252-730-A

1. Adjust the guide T6 zenith check tool by referring to section 2-9 before replacing the T roller base.
2. Remove the T guide base assembly by referring to Figure 6-118.
3. Remove the T roller base from the T guide base assembly.
4. Replace the T roller base with a new one and attach it again.
5. Place the T guide base assembly so that it matches the guide pin. Then, slightly tighten the two screws (C3 x 12) with washer (W3) and spring washer (SW3) to hold the T guide base assembly.
6. Set the T guide base assembly at the center of its play and mark the position of the T roller base as shown in Figure 6-119.
7. Check that the reel table is at the M cassette position. If it is at the L cassette position, set the reel table in the M cassette position by rotating the shift motor manually.
8. Set the reel plate.
9. Remove the END sensor. (Figure 6-118)
10. Check that the inclination in the direction x or y meets the following specification by placing the guide T6 zenith check tool against the T6 guide.

Spec.: X: $\pm 20 \mu\text{m}$
Y: -40 to -60 μm

Note: Check that the probe of the guide T6 zenith check tool is not touching the flange. If it is, adjust the height of the T6 guide.
11. If it is not met, insert one of the following spacers in the place shown in Figure 6-118.

Spacer

| Thickness (μm) | Part Number |
|-----------------------------|--------------|
| 10 | 3-715-319-01 |
| 20 | 3-715-319-11 |
| 30 | 3-715-319-21 |
| 50 | 3-715-319-31 |

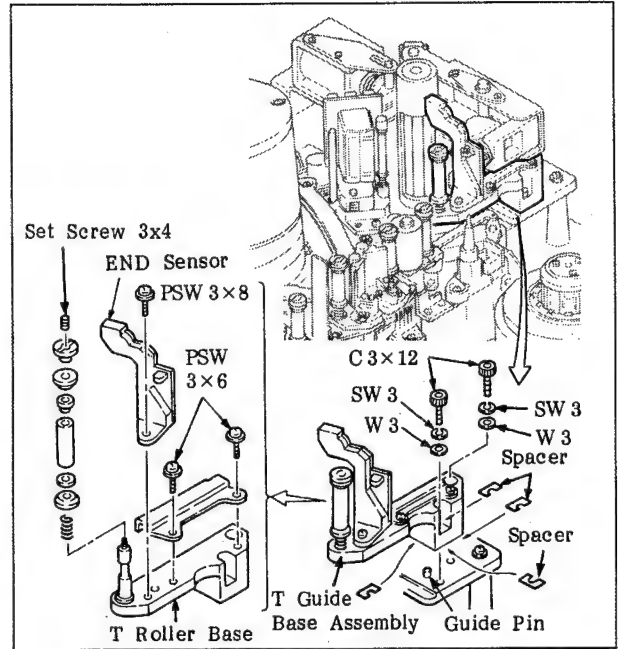

Fig. 6-118 Replacement of the T Roller Base

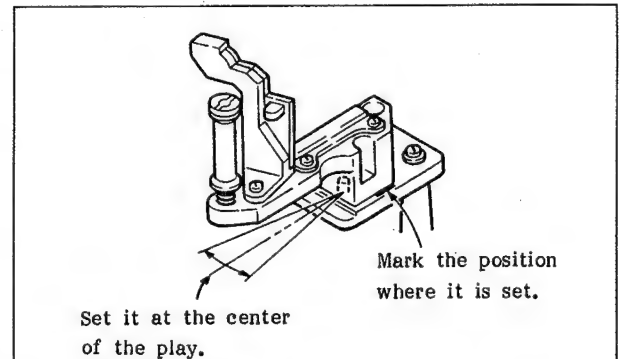

Fig. 6-119 Adjustment of the Position of the T Guide Base Assembly

Adjustment of the Height of the T6 Guide

12. Push the reel table height adjustment tool against the T6 guide, as shown in Figure 6-121. Check that the tool is in contact with the upper flange. If it is not, adjust it by loosening the set screw that holds the T6 guide and by rotating the flange holder, as shown in Figure 6-122.
13. Tighten the set screw and then perform step 12 again.
14. Install the END sensor with the set screw (PSW3x8) and remove the reel plate.
15. Make the following adjustment.

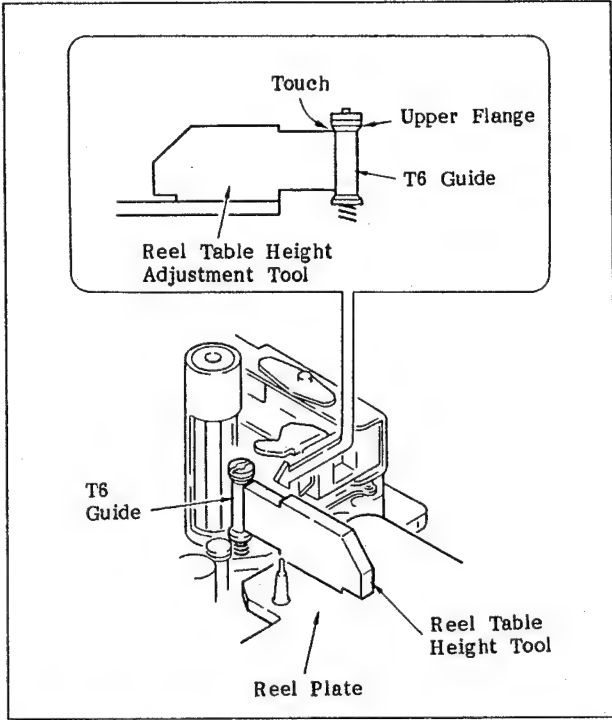
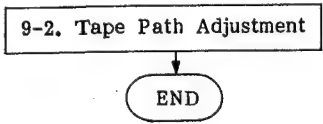

Fig. 6-121 Check of the Height of the T6 Guide

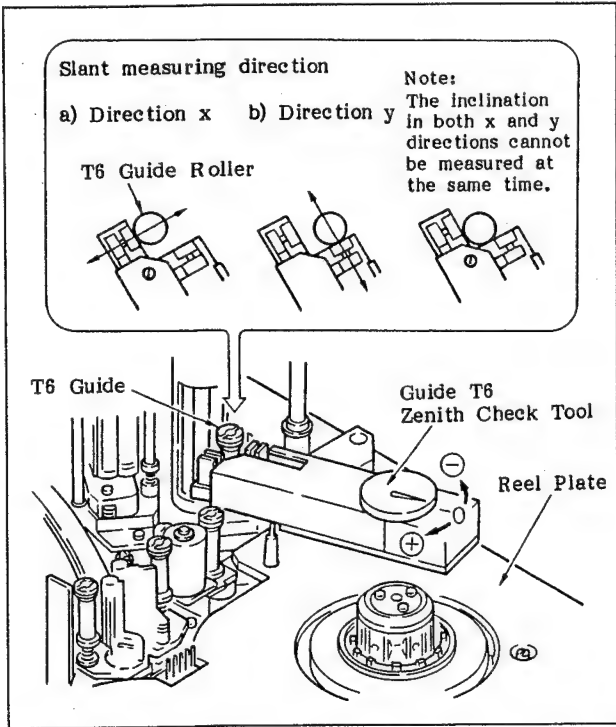

Fig. 6-120 Measurement of the Inclination of the T6 Guide

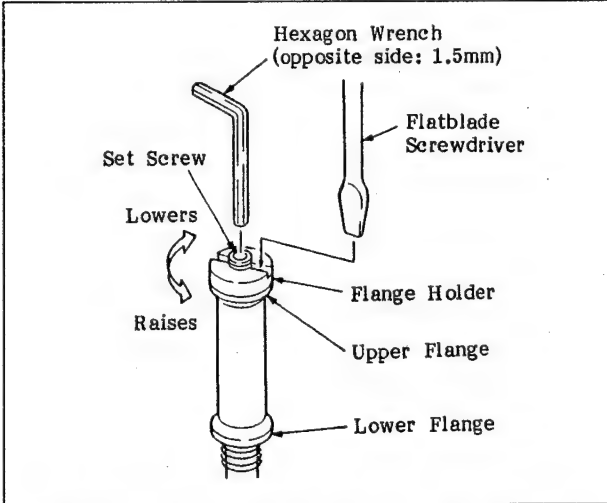

Fig. 6-122 Adjustment of the Height of the T6 Guide

6-15-10. Replacement of the T6 Guide Roller

Background Knowledge

Use the following tools for making the adjustments.

Reel Plate: J-6251-170-B

Reel Table Height Adjustment Tool: J-6252-190-A

T6 Guide Gauge: J-6253-030-A

Replacement

1. Remove the guide roller by rotating the flange holder and replace the guide roller with a new one. (Figure 6-123)

Adjustment

2. Push the T6 guide gauge against the T6 guide, as shown in Figure 6-124. Check the clearance between the T6 guide and the T6 guide gauge.
3. If it is not satisfied, adjust it by changing the number of spacers (R) (Sony Part No. 3-715-809-11), shown in Figure 6-123.

Note: At least one spacer (R) must be inserted between the lower flange and the guide roller.

4. Check that the guide roller rotates smoothly and then perform step 2 again.
5. Shift the reel motor to the M cassette position and then set the reel plate.
6. Push the reel table height adjustment tool against the T6 guide by referring to Figure 6-121. Check that the tool is in contact with the upper flange. If it is not, adjust it by loosening the set screw and rotating the flange holder.
7. Tighten the set screw and perform step 6 again.
8. Remove the reel plate.

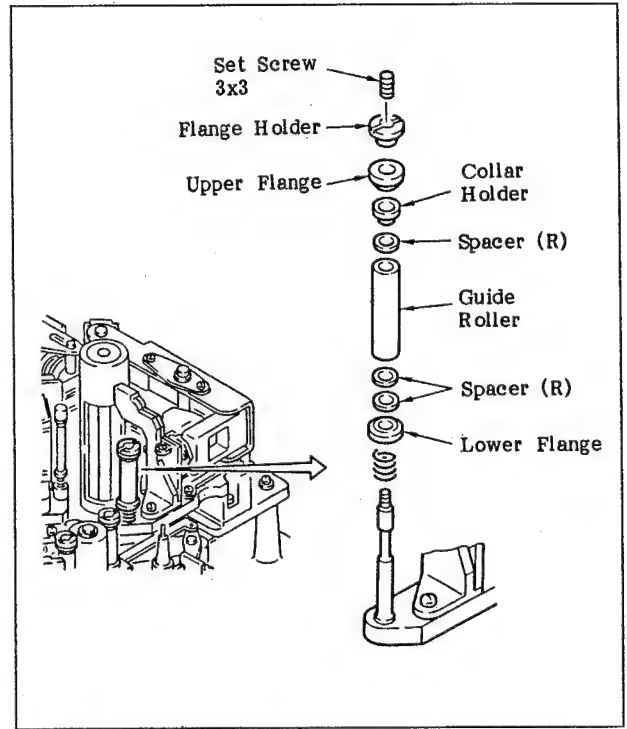

Fig. 6-123 Replacement of the T6 Guide Roller

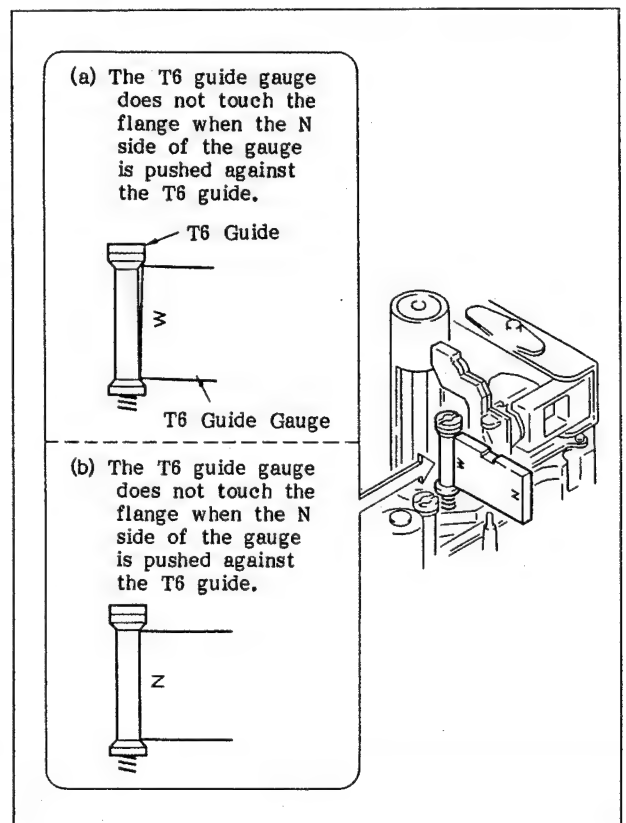

Fig. 6-124 Adjustment of the T6 Guide Roller

6-16. STATIONARY HEAD

6-16-1. Replacement of the Stationary Head

Background Knowledge

Use the following tool for replacement.

Flat plate: J-6252-300-A

1. Disconnect the three connectors and leads from the stationary head assembly.
2. Unscrew the two screws that hold the stationary head assembly and remove the assembly.
3. Remove the stationary head and replace it with a new one by referring to Figure 6-125.

Note: If spacers have been inserted between the fixed head and the base, or between the capstan plate and the fixed head base before replacement of the fixed head, make sure that the same spacers are inserted in the same positions after replacement.

4. Place the flat plate between the parallel pin and the stationary head as shown in Figure 6-126.
5. Tighten the two screws (P2.6 x 4) to hold the head while pushing it in the direction of the arrow as shown in Figure 6-126.
6. Reattach the removed components by referring to Figure 6-125.
7. Attach the stationary head assembly to the machine and connect the removed leads and connectors.

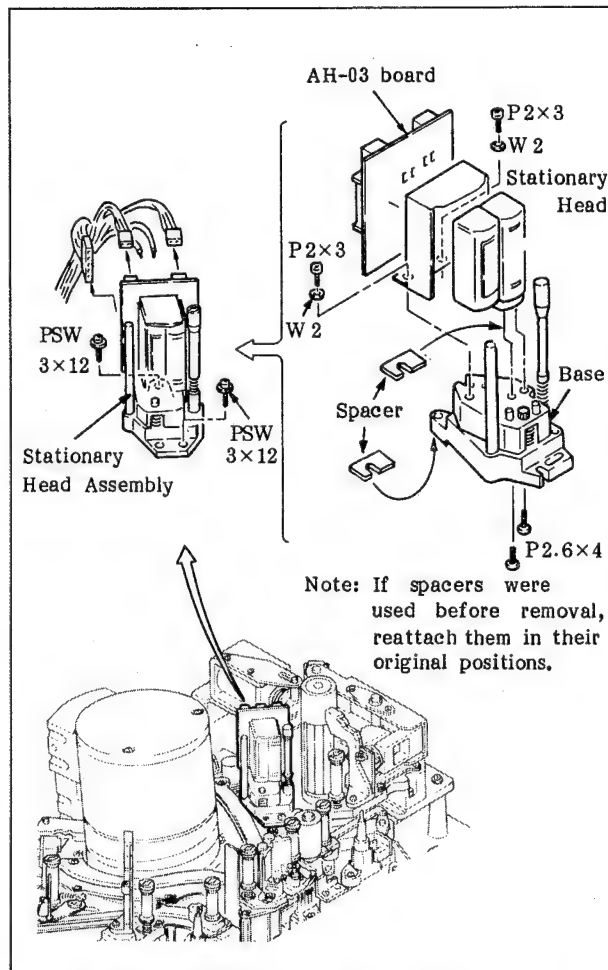

Fig. 6-125 Replacement of the Stationary Head

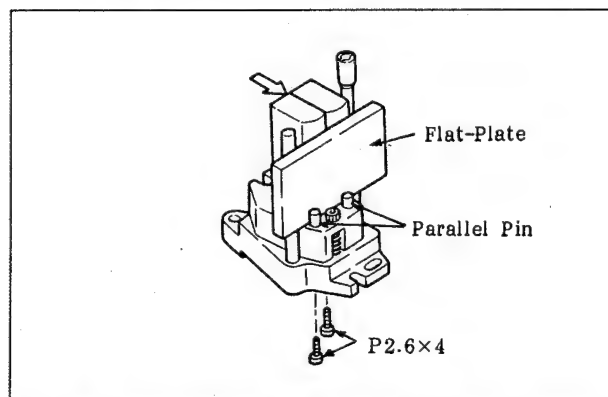
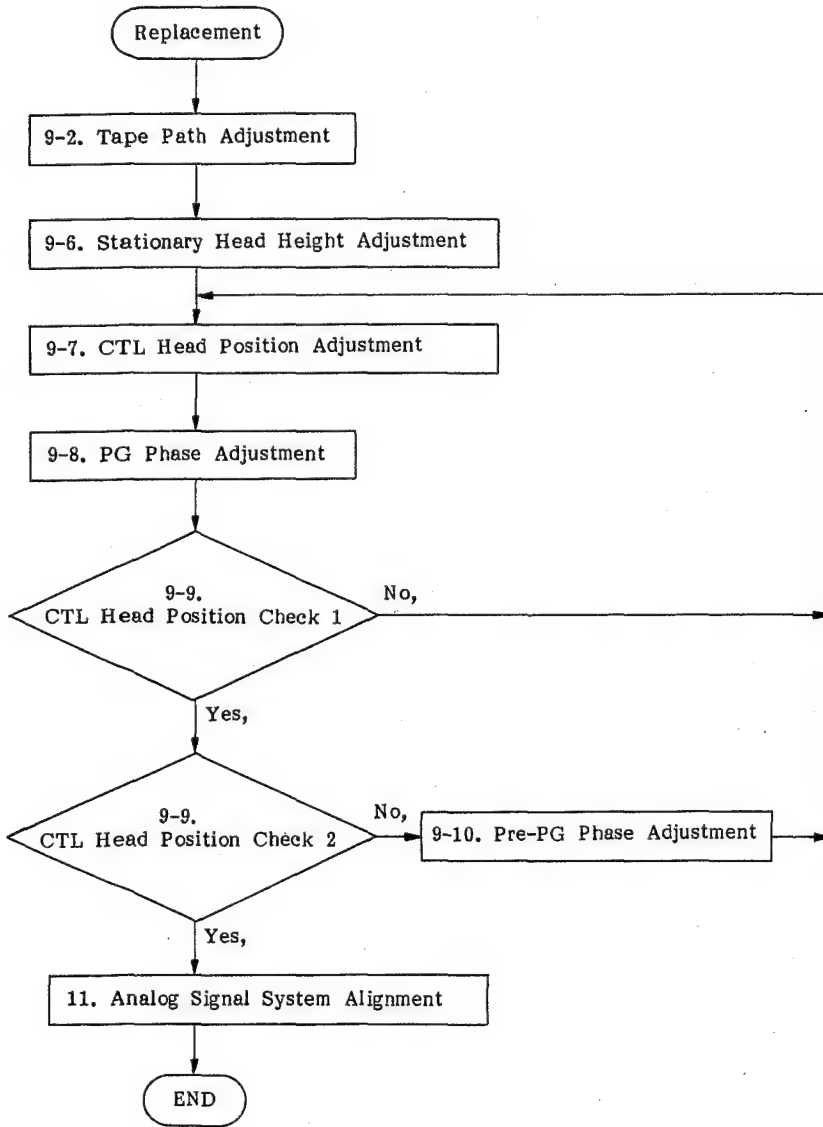
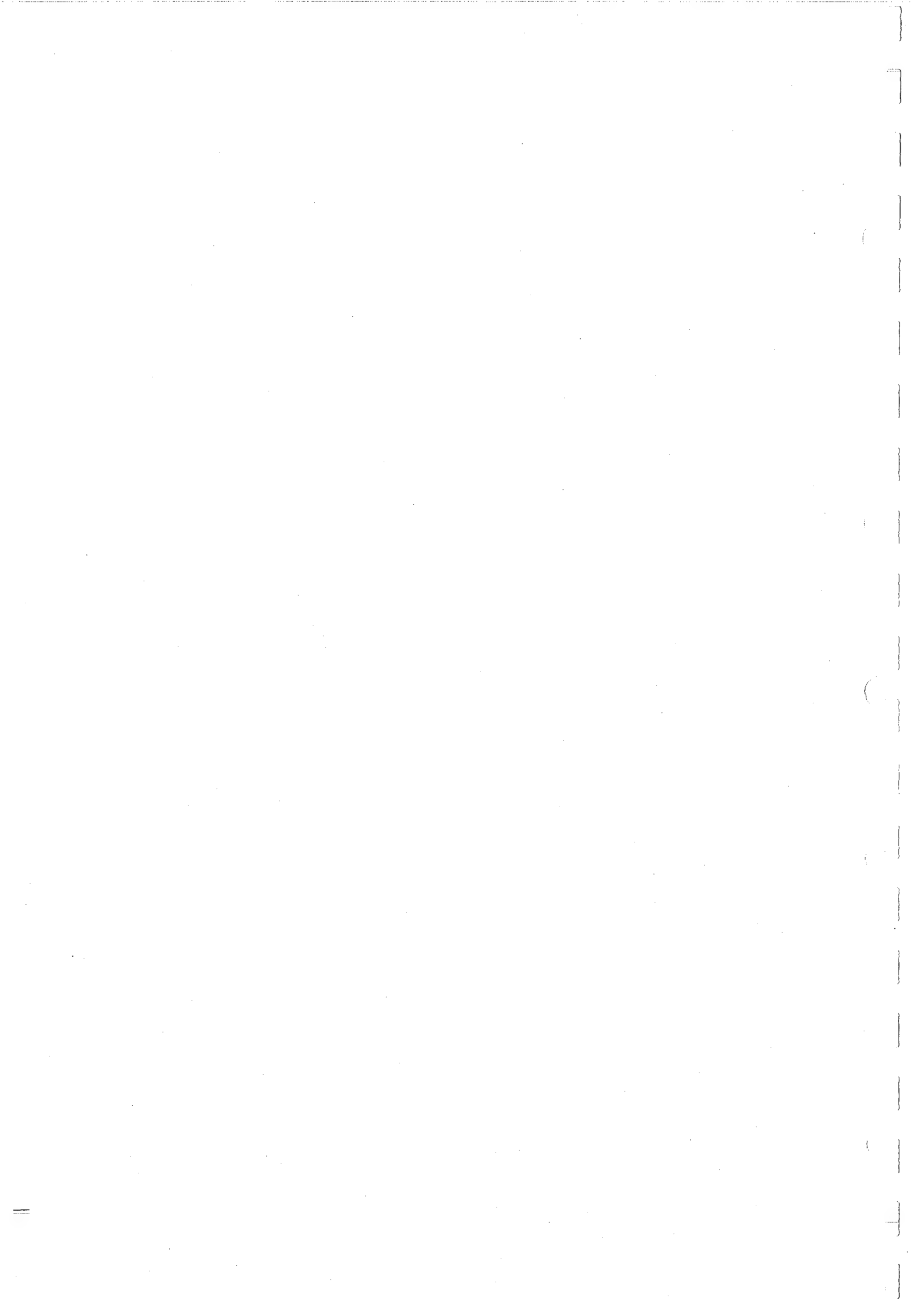

Fig. 6-126 Adjustment of the Position of the Stationary Head

6-16-2. Adjustment to be Made after Replacing the Stationary Head

Make the following adjustment when the stationary head assembly has been replaced.





SECTION 7 GENERAL INFORMATION FOR ALIGNMENT

7-1. INDEX OF ALIGNMENT COMPONENTS

AE-05 BOARD

| | Section |
|--------------------------------------|---------|
| LV101:CUE BIAS RESONANCE | 11-7 |
| LV201:TC BIAS RESONANCE | 11-7 |
| LV501:CUE ERASE RESONANCE | 11-8 |
| LV502:TC ERASE RESONANCE | 11-8 |
| LV503:FULL/CTL ERASE RESONANCE | 11-8 |
| | |
| RV101:D MIX LEVEL | 11-4 |
| RV102:CUE CMR | 11-2 |
| RV103:CUE REC PRESET LEVEL | 11-3 |
| RV104:CUE REC LEVEL | 11-12 |
| RV105:CUE REC EQ | 11-13 |
| | |
| RV106:CUE BIAS LEVEL | 11-10 |
| RV107:CUE PB EQ LEVEL | 11-8 |
| RV108:CUE PB PRESET LEVEL | 11-7 |
| RV109:CUE METER LEVEL | 11-6 |
| RV201:TC REC LEVEL | 11-14 |
| | |
| RV202:TC BIAS LEVEL | 11-10 |
| RV203:TC CANCEL WFM | 11-15 |
| RV204:TC CANCEL PHASE | 11-15 |
| RV205:TC PB LEVEL | 11-9 |
| RV206:TC COMPARE LEVEL | 11-16 |
| | |
| RV301:CTL REC LEVEL | 11-14 |
| RV303:TC CANCEL LEVEL | 11-15 |
| RV304:CTL PB LEVEL | 11-9 |
| RV305:CTL COMPARE LEVEL | 11-16 |
| RV501:CUE ERASE LEVEL | 11-11 |
| | |
| RV502:TC ERASE LEVEL | 11-11 |
| RV503:FULL/CTL ERASE LEVEL | 11-11 |

CT-74 BOARD

| | Section |
|------------------------------------|---------|
| RV1: SWITCHING CURRENT LIMIT | 8-5 |

DET-3 BOARD

| | Section |
|--------------------------------|---------|
| RV1: DIAL PUSE AMP (CHA) | 13-3 |
| RV2: DIAL PUSE AMP (CHB) | 13-3 |

LO-05 BOARD

| | Section |
|-----------------------------------|---------|
| RV1: CUE OUTPUT LEVEL | 11-5 |
| RV2: TIME CODE OUTPUT LEVEL | 11-5 |
| RV3: MONITOR R OUTPUT LEVEL | 11-5 |
| RV4: MONITOR L OUTPUT LEVEL | 11-5 |

PC-36 BOARD

| | Section |
|-------------------------------|---------|
| RV1: SENSOR SENSITIVITY | 10-8 |

PS-139 BOARD

| | Section |
|--------------------------------|---------|
| RV1: +15V OUTPUT VOLTAGE | 13-2 |
| RV2: +15V CURRENT LIMIT | 13-2 |
| RV3: +5V OUTPUT VOLTAGE | 13-2 |
| RV4: +5V CURRENT LIMIT | 13-2 |

RE-32 BOARD

| | Section |
|--|---------|
| RV1: +12V OUTPUT VOLTAGE | 8-3 |
| RV2: +12V CURRENT LIMIT | 8-4 |
| RV3: -12V OUTPUT VOLTAGE | 8-3 |
| RV4: -12V CURRENT LIMIT | 8-4 |
| RV5: -5V OUTPUT VOLTAGE | 8-3 |
| RV6: -5V CURRENT LIMIT | 8-4 |
| RV7: +5V OUTPUT VOLTAGE | 8-2 |
| RV8: +5V RIPPLE | 8-2 |
| RV9: +5V CURRENT LIMIT | 8-2 |
| RV10: +14V & +40V OUTPUT VOLTAGE | 8-7 |

RE-44 BOARD

| | Section |
|--------------------------------|---------|
| RV1: ENCODER PULSE AMP B | 13-4 |
| RV2: ENCODER PULSE AMP A | 13-4 |

RF-15 BOARD (); -11,-12

| | Section |
|----------------------------------|---------|
| LV1(L3): A-CH PB EQ LPF | 12-3 |
| LV2(L4): B-CH PB EQ LPF | 12-3 |
| LV3(L5): C-CH PB EQ LPF | 12-3 |
| LV4(L6): D-CH PB EQ LPF | 12-3 |
| | |
| RV1: ADVANCE A/B-CH WINDOW | 12-2 |
| RV2: ADVANCE C/D-CH WINDOW | 12-2 |
| RV3: A-CH ENVELOPE LEVEL | 12-5 |
| RV4: B-CH ENVELOPE LEVEL | 12-5 |
| RV5: C-CH ENVELOPE LEVEL | 12-5 |
| | |
| RV6: D-CH ENVELOPE LEVEL | 12-5 |
| RV7: A-CH PB EQ OFFSET | 12-3 |
| RV8: B-CH PB EQ OFFSET | 12-3 |
| RV9: C-CH PB EQ OFFSET | 12-3 |
| RV10: D-CH PB EQ OFFSET | 12-3 |

RV11: A-CH ADVANCE PB OF ENVELOPE LEVEL

| | |
|---|------|
| 12-5 | |
| RV12: B-CH ADVANCE PB OF ENVELOPE LEVEL | 12-5 |
| RV13: C-CH ADVANCE PB OF ENVELOPE LEVEL | 12-5 |
| RV14: D-CH ADVANCE PB OF ENVELOPE LEVEL | 12-5 |

RS-23 BOARD

| | Section |
|-------------------------------------|---------|
| RV1: DAC OFFSET | 10-3 |
| RV2: DAC GAIN | 10-2 |
| RV3: ANALOG REFERENCE VOLTAGE | 10-2 |

7-2. EQUIPMENT REQUIRED

1. Oscilloscope

TEKTRONIX Type 465B or Equivalent

2. Digital Voltmeter

Effective digits; more than 4 1/2 digits
Accuracy; less than 0.02% ±1 count

3. Extender; EX-129 (Supplied with DVR-1000)

SONY Part No. A-6001-011-A

4. Alignment Tape SONY Part No.

525/60 System; BR-5-1A 8-960-070-01

625/50 System; BR-5-1B 8-960-070-51

5. DC Ammeter

Range; 10A

6. Audio Distortion Analyzer

HEWLETT PACKARD Type 8903A or Equivalent

7. Processor

SONY DVPC-1000

8. IC Test Clip

Type TC-16: SONY Part No. J-6041-770-A

Type TC-20: SONY Part No. J-6041-780-A

Manufacture:

AP PRODUCTS INCORPORATED

P.O.Box 697, 72 Corwin Drive

Peinesville, Ohio 44077, U.S.A.

Tel: (216) 354-2101

When connection the test probe to the terminal of DIP integrated circuit, these clips are convenient. Type TC-16 is for DIP 14-pin or 16-pin IC and Type TC-20 is for 18-pin or 20-pin IC.

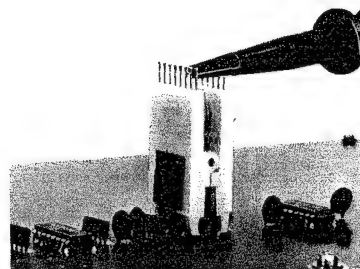

7-3. CONNECTIONS

CONNECTION 1.

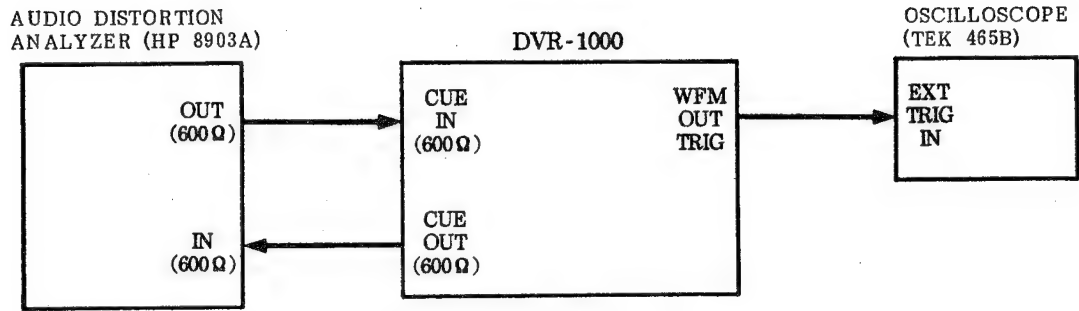

CONNECTION 2.

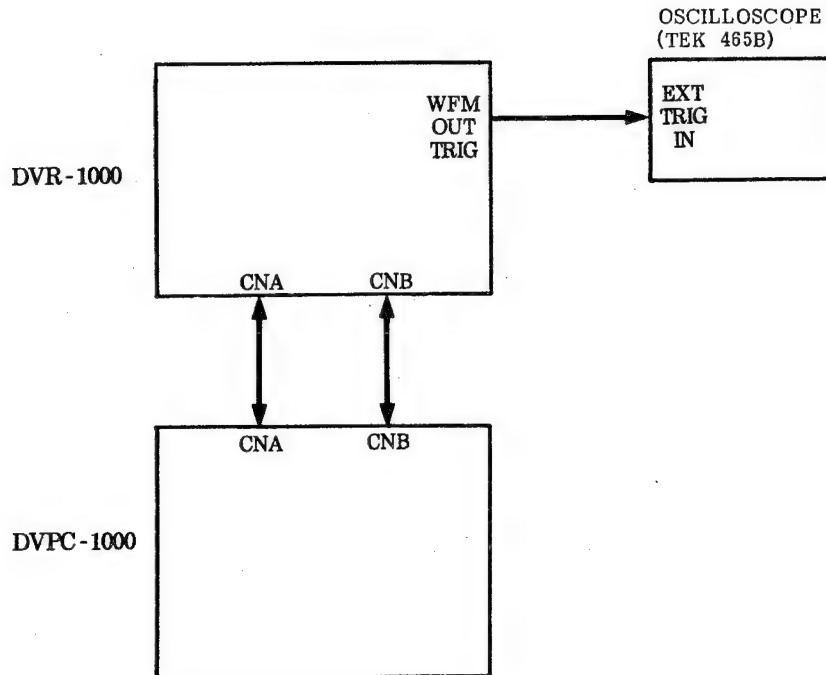

7-4. INITIAL SETTING OF THE SWITCHES/JUMPERS

POWER SUPPLY

S002: VOLTAGE SELECTOR.....Depend on usage

CONNECTOR PANEL

S003: INPUT IMPEDANCE SELECT SW.....Depend on usage

S004: INPUT IMPEDANCE SELECT SW.....Depend on usage

CP-106 BOARD

S1: RESET SW.....Used for testing

IF-138 BOARD

S1: RESET SW.....Used for testing

SY-69 BOARD

S1: SETUP SW.....Used for testing

RF-15 BOARD (Board No. 1-620-901-11)

JP5: ADVANCE HEAD TEST.....OPEN

RF-15 BOARD (Board No. 1-620-901-12)

JP1/2:ADVANCE HEAD TEST.....JP2

SP-01 BOARD

S1: SYSTEM RESET SW.....Used for testing

S2: NOVDRAM WR SW.....Used for testing

S3: MOTOR ALL OFF SW (NORMAL/HOLD)...NORMAL



7. GENERAL INFORMATION FOR ALIGNMENT

SECTION 8 POWER SUPPLY ALIGNMENT

CT-74 board (component side)

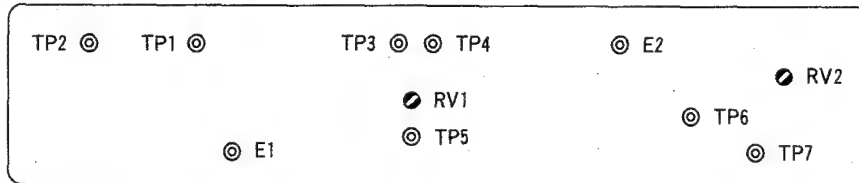

RE-32 board (component side)

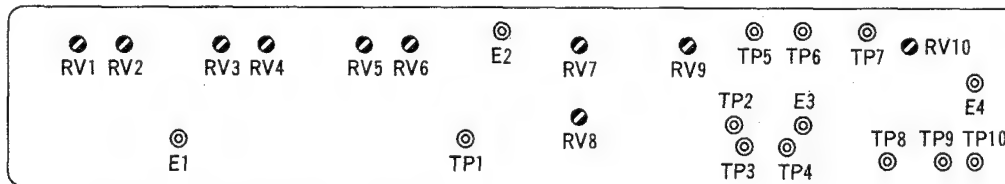

The RE-32 and CT-74 board adjustments can be performed from the holes shown in the figure below with the power supply removed from the main unit. The power supply cover should be removed following the procedure in Section 2-4-4 if the adjustments are to be carried out while observing the waveforms at the TP pins inside.

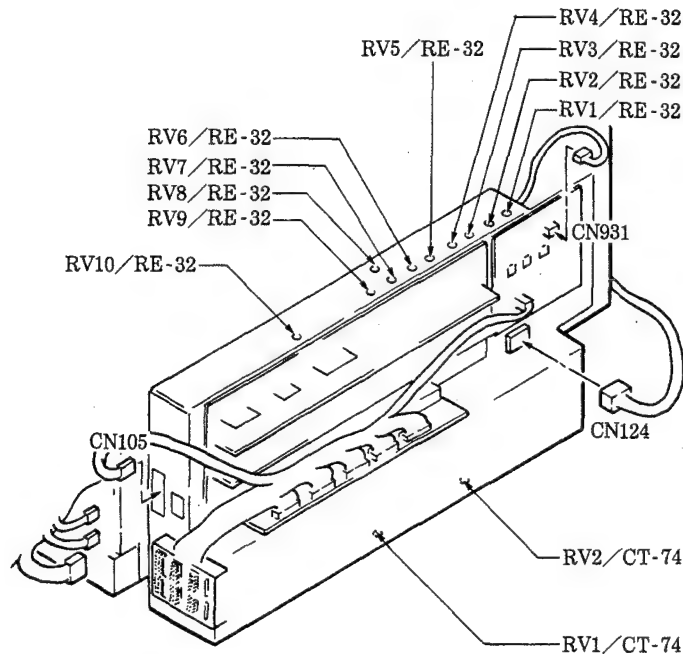

Notes:

- (1) Read the precautions concerning the power supply area in Section 2-3 before proceeding to inspect and adjust the power supply area.
- (2) Adjustment of the supply voltage should be avoided unless it is quite clear that such adjustment is necessary.
- (3) When any of the variable resistors below have been replaced, set them to the following positions before proceeding to adjust them.

CT-74 board

RV1 Mechanical center

RE-32 board

RV1 Mechanical center
RV2 Clockwise fully
RV3 Mechanical center
RV4 Clockwise fully
RV5 Mechanical center
RV6 Clockwise fully
RV7 Clockwise fully
RV9 Mechanical center
RV10 Mechanical center

8-1. POWER SUPPLY ALIGNMENT SEQUENCE

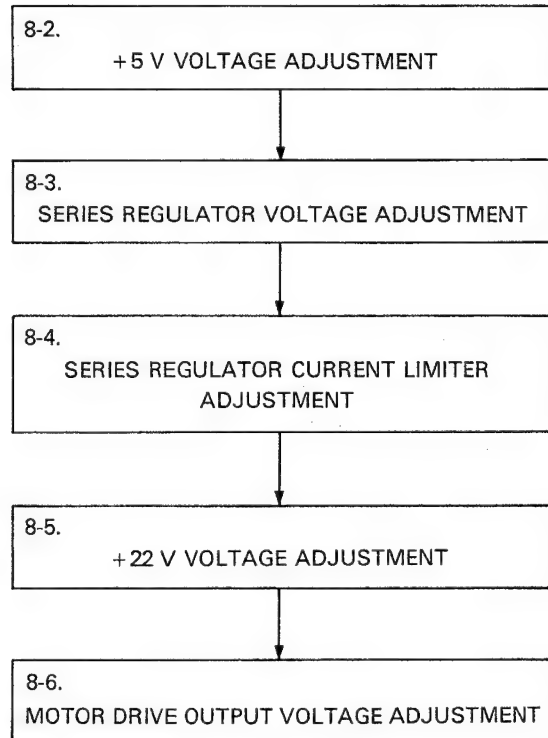

8-2. +5 V VOLTAGE ADJUSTMENT

Equipment: Digital voltmeter, oscilloscope
DVR-1000 mode; STOP

Step 1: +5 V Output voltage adjustment

Switch on the power and adjust the +5 V voltage.

CN728 pin 1/MB-133 = $+5.00 \pm 0.02$ V dc

RV7/RE-32

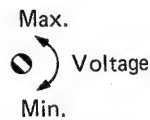

Step 2. +5 V Ripple adjustment

Adjust the ripple to its minimum while observing the oscilloscope.



Step 3:

Note: Proceed with the adjustment below only when RV9 has been replaced. Otherwise, RV9 should not be touched.

Perform the adjustment in (1) if it is possible to obtain the maximum load resistance indicated below.

Perform (2) if this value cannot be obtained.

Resistance: 0.2 to 0.25 ohm

Rated power: 150 W min.

- (1) a. Switch off the power and disconnect CN124 and CN108.
- b. Set RV9/RE-32 to its mechanical center point.
- c. Connect the maximum load resistance across W101 and W103 on the PS-138 board.
- d. Switch on the power and check on the oscilloscope that a voltage of approximately +5 V is output to W103.
- e. Rotate RV9/RE-32 gradually to the clockwise and stop at the point where the W103 output drops sharply.
- f. Switch off the power and connect CN124 and CN108.

PS-138 (soldering side)

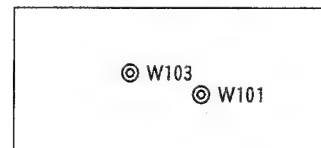

- (2) Adjust RV9/RE-32 to the position indicated in the figure below.

2 scale units from maximum clockwise position

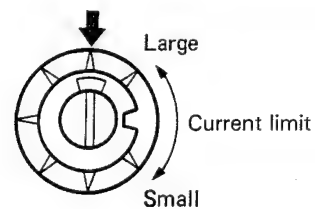

8-3. SERIES REGULATOR VOLTAGE ADJUSTMENT

Equipment; Digital voltmeter
DVR-1000 mode; STOP

Adjustment

CN728 pin 5/MB133 = $+12.00 \pm 0.05V$ dc
 ⊗RV1/RE-32
CN728 pin 4/MB133 = $-12.00 \pm 0.05V$ dc
 ⊗RV3/RE-32
CN728 pin 2/MB133 = $-5.00 \pm 0.02V$ dc
 ⊗RV5/RE-32

(RV1, 3, 5)

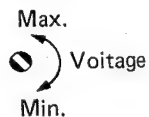

8-4. SERIES REGULATOR CURRENT LIMITER ADJUSTMENT

Equipment; DC ammeter, Extension board EX-129
DVR-1000 mode; STOP

Note:

RV2, 4 and 6 on the RE-32 board should be adjusted as below only when the variable resistor question have been replaced. Otherwise, they should not be touched.

Step 1:

Switch off the power and disconnect the connectors and the circuit boards below:

CN108 (from PS-138 board) RS-23 board
RF-15 board SP-01 board
AE-05 board SY-69 board
CD-35 board

Step 2:

Insert the EX-129 extension circuit board into any of the above six circuit boards and switch on the power.

Step 3: +12 V Current limiter adjustment

Connect the (+) terminal on the DC ammeter to the +12 V TP terminal on the EX-129 extension board and the (-) terminal to the GND TP terminal.

Spec.; Current value = 1.8 ± 0.1 A

⊗RV2/RE-32

Step 4: -12 V Current limiter adjustment

Connect the (+) terminal on the DC ammeter to the GND TP terminal on the EX-129 extension circuit board and the (-) terminal to the -12 V TP terminal.

Spec.; Current value = 1.8 ± 0.1 A

⊗RV4/RE-32

Step 5: -5 V Current limiter adjustment

Connect the (+) terminal on the DC ammeter to the GND TP terminal on the EX-129 extension circuit board and the (-) terminal to the -5 V TP terminal.

Spec.; Current value = 3.3 ± 0.1 A

⊗RV6/RE-32

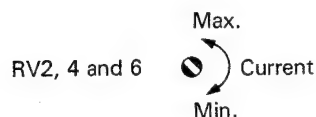

Step 6:

Switch off the power, disconnect the EX-129 extension board and re-connect the connectors and circuit boards which were disconnected in Step 1.



8-5. +22 V VOLTAGE ADJUSTMENT

Equipment; Digital voltmeter
DVR-1000 mode; STOP

Step 1:

Switch off the power and disconnect the following connectors from the circuit boards:

CN108 (PS-138 board)

CN728 (MB-133 board)

CN730 (MB-133 board)

Step 2: +22 V Voltage adjustment

Switch on the power and proceed with the +22 V voltage adjustment.

CN204 pin 1A/FP-24 = $+22.0 \pm 0.1$ V dc

RV2/CT-74

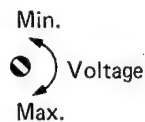

Step 3:

Switch off the power and re-connect the connectors which were disconnected in Step 1.

8-6. MOTOR DRIVE OUTPUT VOLTAGE ADJUSTMENT

Equipment; Digital voltmeter
DVR-1000 mode; STOP

Adjustment; +14 V Output voltage

CN105 pin 1A or 1B/PS-138 = $+15.0 \pm 0.1$ V dc

RV10/RE-32



SECTION 9 TAPE PATH SYSTEM ALIGNMENT

This section describes how to adjust the tape transport system. Refer to the flowchart below for detecting nonconformity in the system and for adjusting the parts that affect tape running are replaced.

9-1. FLOWCHART FOR ADJUSTMENT

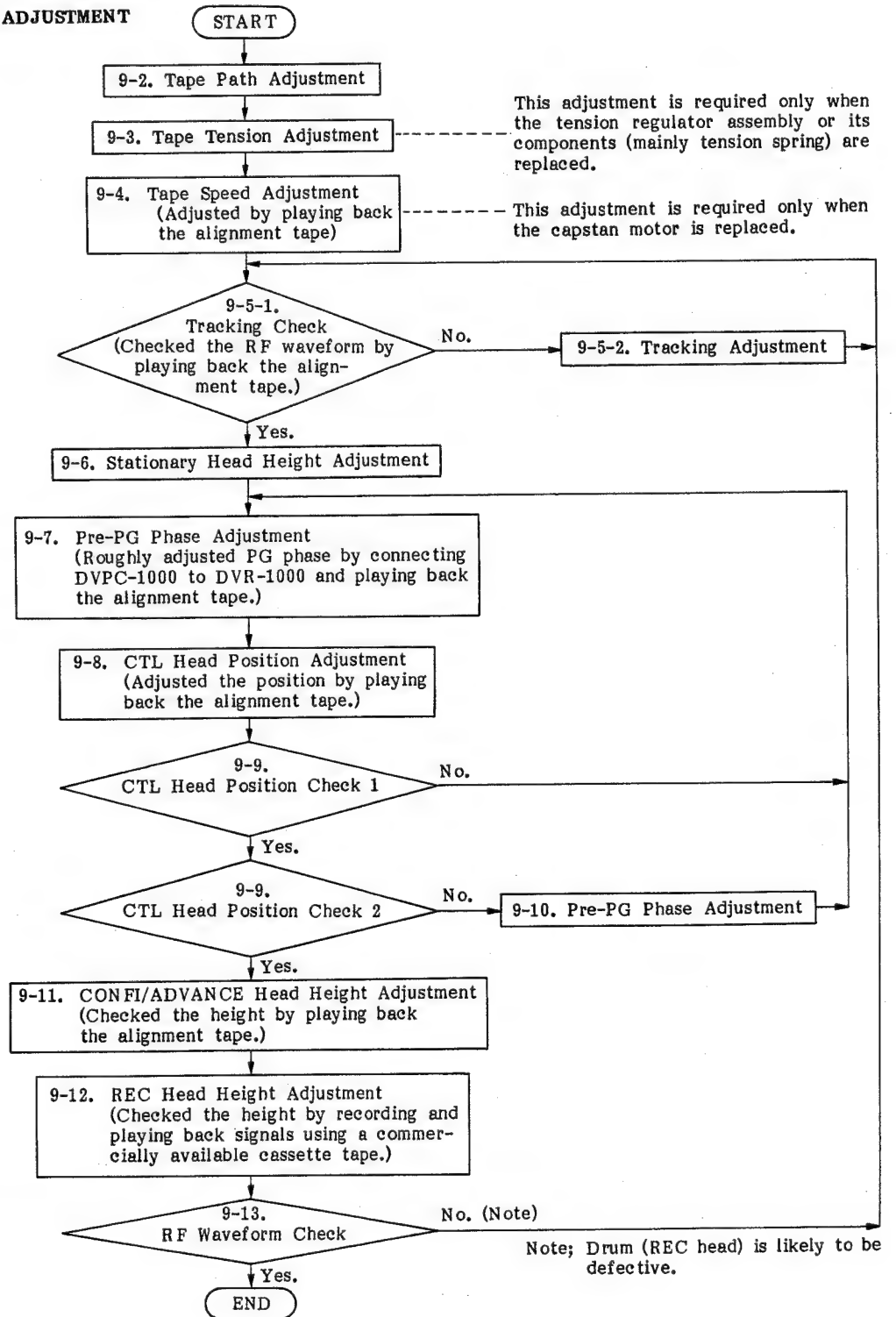

9-2. TAPE PATH ADJUSTMENT

Background knowledge

- A. It is required that the tape touches the reel flanges lightly and curls very little around the flanges of the guides while the tape is running.
- B. It is necessary that the above-mentioned conditions are also met in FF (+40 fast forward), REW (-40 re-wind), REC VAR +1/4 fast forward, and VAR -1/4 rewind modes.
- C. The entrance and exit slant guides are not adjusted here.

Checking the tape path

1. Thread a cassette tape with a little reel flange play, whose winding is not slackened or irregular, and whose edges are not scratched or wrinkled, into the unit.
2. Set the unit in SHUTTLE +1 FF mode and then check the tape transport in the following places.

- ① S reel: The tape touches the reel flange very little while running.
- ② S5 guide: The tape is in contact with the upper and lower flanges of the guide, but curls very little.
- ③ S4 guide: The tape touches the lower flange of the guide, but curls very little around the edges.
- ④ S3 guide: The tape touches the lower flange of the guide, but curls very little around the edges.
- ⑤ S2 guide: The tape touches the upper flange of the guide, but curls very little around the edges.
- ⑥ Drum: The tape runs along the lead and does not float or come off from the lead.
- ⑦ T2 guide: The tape touches the upper flange of the guide, but curls very little around the edges.
- ⑧ T4 guide: The tape touches the upper and lower flanges of the guide, but curls very little around the edges.
- ⑨ PS guide: The tape is in contact with the guide, but no wrinkling occurs.
- ⑩ T5 guide: The tape touches the lower flange of the guide, but curls very little around the edges.
- ⑪ T6 guide: The tape touches the upper and lower flanges of the guide, but curls very little around the edges.
- ⑫ T reel: The tape touches the reel flange very little while running.

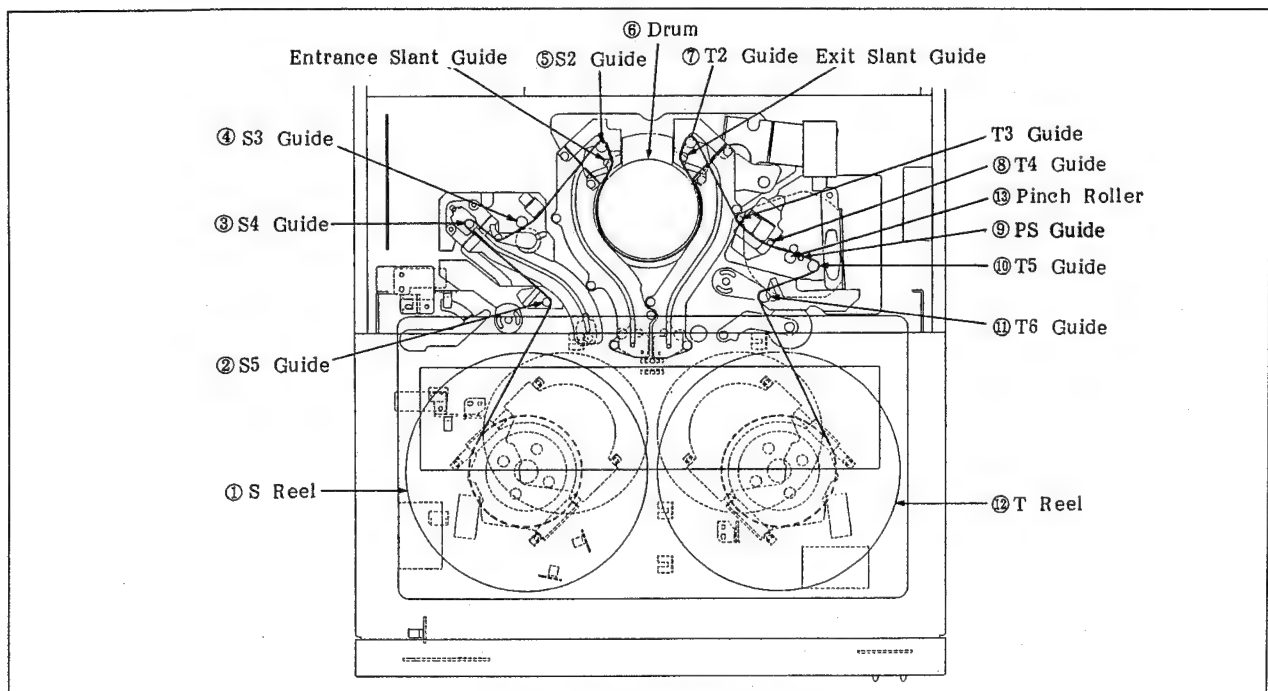

Fig. 9-1 Tape Transport Check

3. If the tape path does not satisfy the above-mentioned items, adjust it according to the adjustment procedure.
4. Set the unit in SHUTTLE -1 FF mode and then check the items of Step 2.
5. Set the unit in REC mode, in VAR +1/4 forward mode, and in VAR -1/4 rewind mode in that order, and then, check the following items in addition to the items of Step 2.
- ⑬ The tape must not be wrinkled around the pinch roller.
6. If the transport does not satisfy the items ① through ⑬, adjust it according to the adjustment procedure.

Adjustment of the height of the guides

The standard height of the guides are indicated in Fig. 9-2. When parts are replaced or when the height of the guides has been changed greatly, adjust the height of each guide as shown in the figure below before installing the part.

Note 1: Do not adjust the heights of the guides unnecessarily. Especially, do not adjust the heights of the entrance and exit slant guides, except when the tracking adjustment is being performed.

Note 2: Refer to the corresponding adjustment section for adjusting the stationary head assembly, full erase head, tension regulator, and pinch roller.

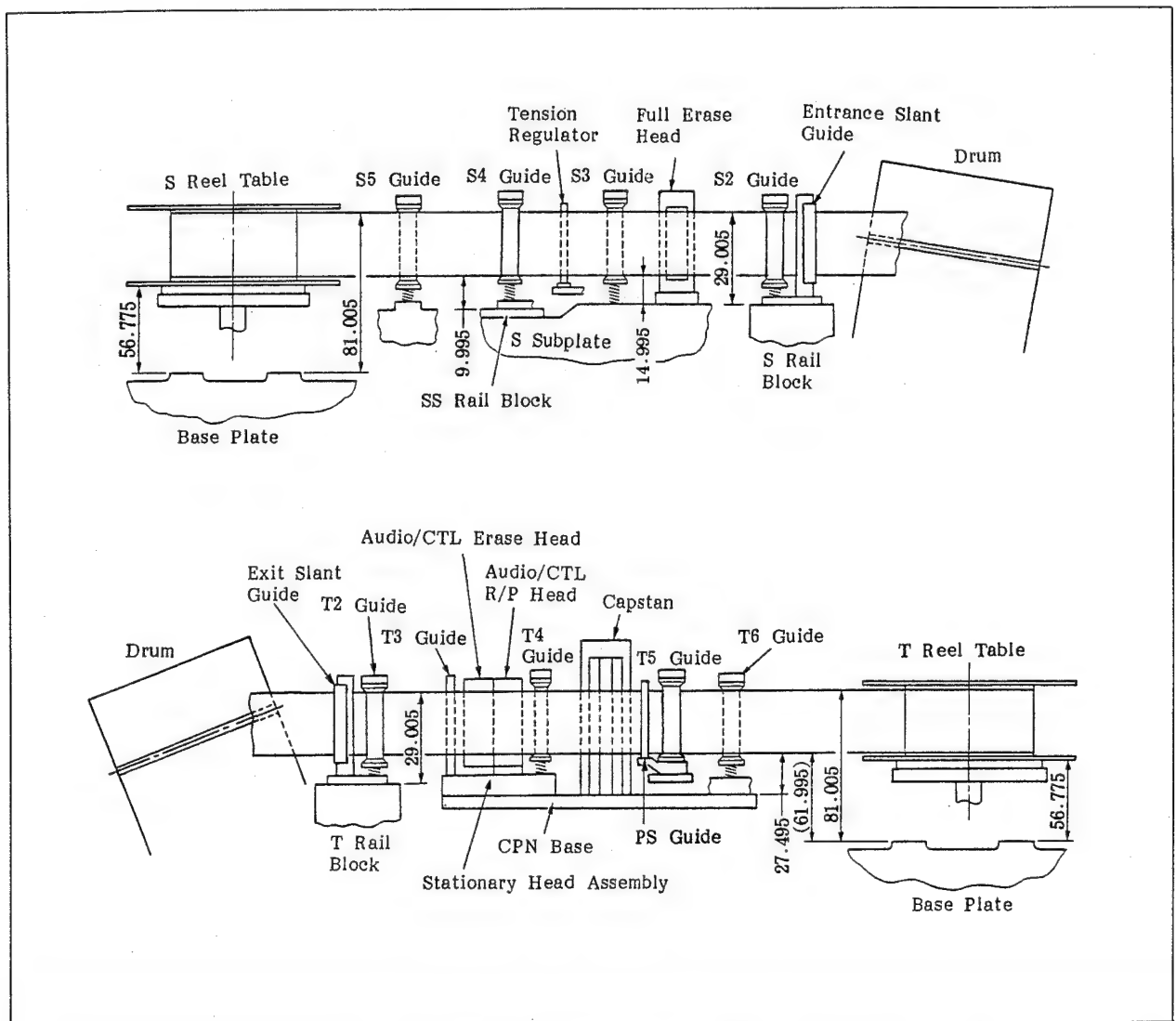

Fig. 9-2 Height of Guides



Adjusting the height of the S and T reel tables

Note: This adjustment does not necessary to perform in usual tape path adjustment. If the tape contacts with reel flange strongly, adjust the reel height referring to the section 6-6 (Reel Motor Replacement). However, if the tape still contacts with the flange strongly even after adjustment, perform the following adjustment.

1. Loosen the set screws A and B with a hexagon wrench (opposite side: 2mm).
2. Push the reel table down lightly in the direction of the arrow, as shown in the figure. Then, adjust the height by turning the set screw C with a hexagon wrench (opposite side: 1.5 mm) so that the tape runs without touching the flange surface.
3. Tighten the set screws A and B.

Note: If the tape touches the reel flange even after this adjustment, check the following.

- ① Whether or not one of the reel flanges of the cassette is deformed.
- ② Whether or not the sheet of the reel table is deformed or whether some foreign material is stuck to it.
- ③ Whether or not an unusual noise is generated by the reel motor.

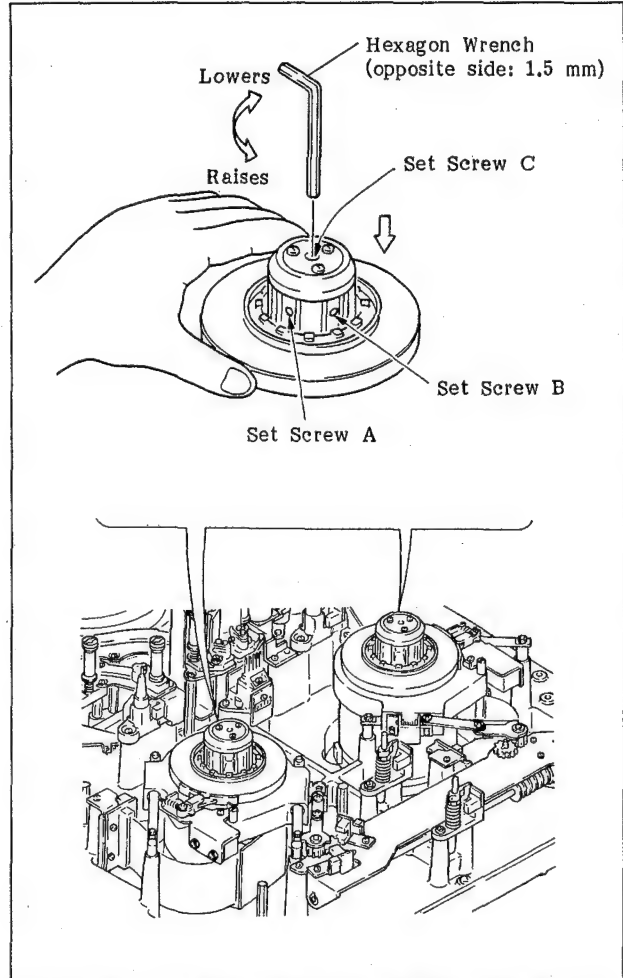

Fig. 9-3 Height Adjustment of Reel Tables

Adjustment of the height of the guide rollers (S5, S4, S3, S2, T2, T5, T6)

Note: Do not adjust the S2 and T2 guides in the usual tape path adjustment unnecessarily.

1. Loosen the set screw.
2. Adjust the height of the guide rollers by turning the flange holder of the guide roller with a flatblade screwdriver as shown in the figure.
 - ① Adjust the height of the S5, the S2, the T2, and the T6 guide rollers so that the tape touches the upper flange slightly when running. (Refer to the tape path check section for the details.)
 - ② Adjust the height of the S4, the S3, and the T5 guide rollers so that the tape touches the lower flange slightly when running. (Refer to the tape path check section for the details.)

3. Tighten the set screw that was loosened in Step 1.

Note: If a large amount of powder drops from the tape, check the ceramic flange. When powder is dropping from a ceramic flange, rotate the flange so that the tape is in contact with another portion of the flange. If powder drops even after that, replace the ceramic flange with a new one.

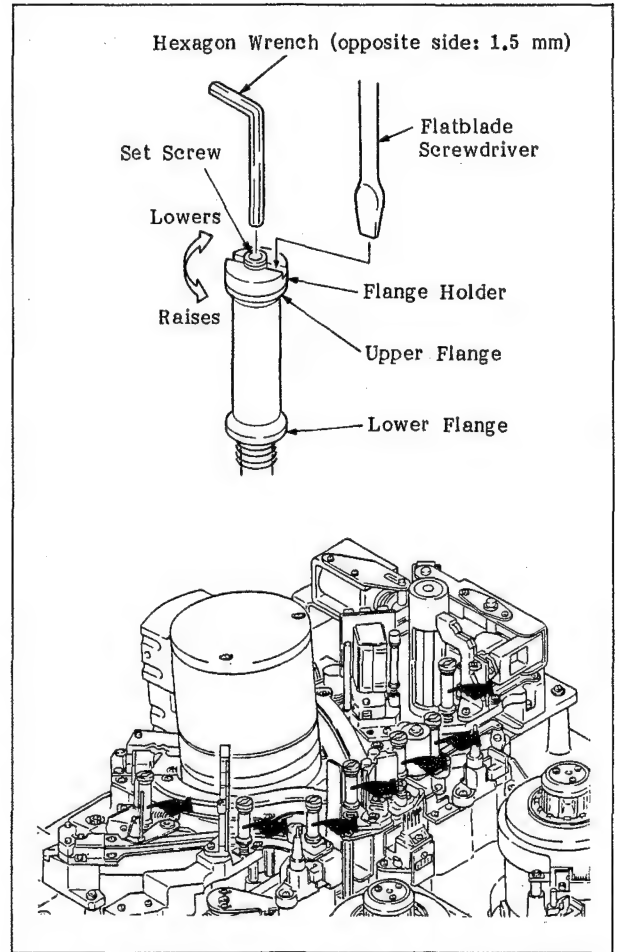

Fig. 9-4 Adjustment of the Height of Guide Rollers

Adjusting the height of the guide post (T4)

1. Loosen the set screw.
2. Adjust the height of the guide post by turning the flange holder of the guide with a flatblade screwdriver so that the tape touches the lower flange slightly when running and so that it does not curl very little along the edges.
3. Tighten the set screws.

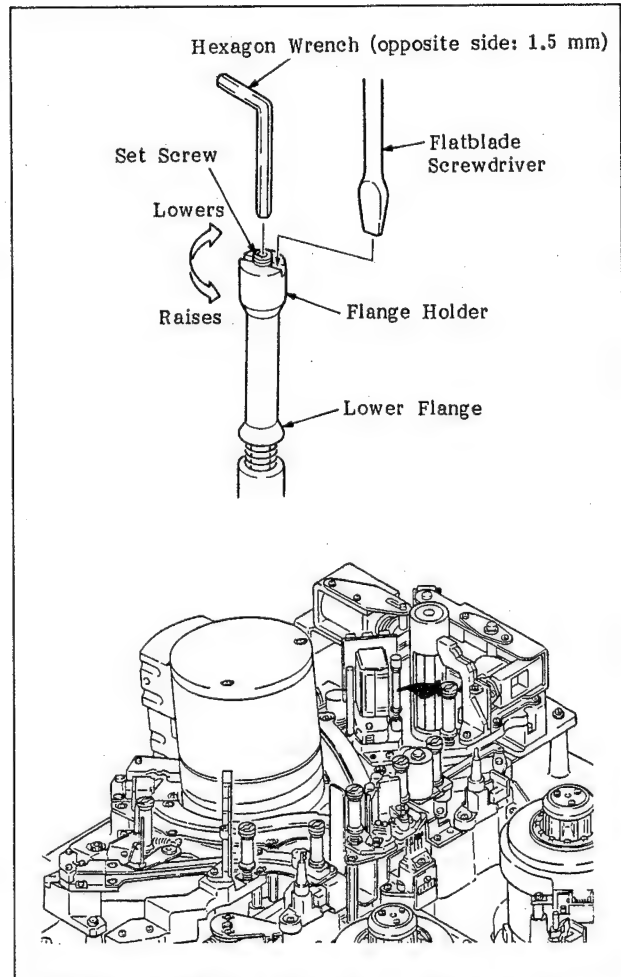

Fig. 9-5 Height Adjustment of the Guide Post



9-3. TAPE TENSION ADJUSTMENT

Background knowledge

- A. The tape tension in REC and PLAY modes are adjusted here. The tape tension around the drum in REC and PLAY modes are determined by the S reel motor, the tension regulator, and the capstan motor.
- B. Prepare the following tool for this adjustment.
 - . Tension adjustment tool (JB-5187): J-6251-870-A
 - . Extension Board (EX-129): A-6011-011-A
- C. If the tape tension is not adjusted by the following procedure and the DME that is built in the tension regulator assembly is considered to be defective, replace the whole tension regulator assembly. Also, in case the components, such as the tension regulator shaft are worn down or damaged, replace the whole tension regulator assembly.
- D. This adjustment is required only when the tape tension between the S2 and the S3 guides in REC mode does not meet the specification ($30\text{ g} \pm 3\text{ g}$) or when the tension spring for the tension regulator is replaced.

Adjusting the position

1. Pull out the RS-23 board.
2. Turn the power of the unit on. Then, press the **TEST**, the **F3** (CHECKER), the **F1** (CONTINUE) keys on the control panel in that order to set the unit in checker mode.
3. Press the **F3** (C), the **4**, the **SET**, the **F6** (F), the **2**, the **SET**, and the **<** keys in that order to set the unit in threading condition without threading a cassette tape.
4. Loosen the two set screws (+PSW 3 x 8) that hold the tension regulator by one or two turns. Match the groove of the tension regulator to the groove of the S plate, as shown in Fig. 9-6-1 and then tighten the set screws.
5. Put the tension adjustment tool over the upper flange of the guide roller and tighten the fixing knob while pushing the tool down. (Fig. 9-6-1)

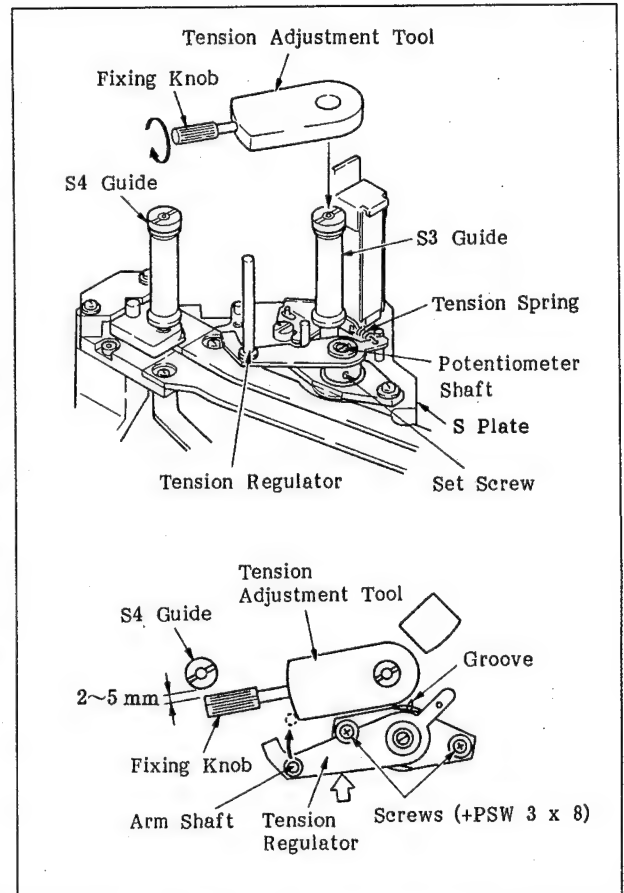

Fig. 9-6-1 Tape Tension Adjustment

Rough adjustment

6. Loosen the set screw of the tension regulator.
7. Connect a digital voltmeter between GND and pin 1 (+) of the ICE4/RS-23 board.
8. Rotate the potentiometer shaft clockwise slowly with a screwdriver and find the point where the indicated value of the digital voltmeter changes from the positive value to the negative value. Then obtain the central value (V) from the maximum value and the minimum value.
9. Push the position indicated by the arrow to push the arm shaft of the tension regulator against the tension adjustment tool, as shown in the top view of Fig. 9-6-1. Adjust by rotating the potentiometer shaft so that the indicated value of the digital voltmeter satisfies the following specification.

Standard: Central value (V) $\pm 50\text{mV}$

10. Tighten the set screw of the tension regulator that was loosened in step 6.
11. Check that the indicated value increases when the arm shaft is separated from the tension adjustment tool. If the indicated value decreases, loosen the set screw of the tension regulator and rotate the potentiometer shaft counterclockwise by 90 degrees. Perform Steps 8 through 11 again.
12. Push the arm shaft of the tension regulator against the tension adjustment tool. Check that the indicated value satisfies the following specification.
Standard: Central value (V) $\pm 150\text{mV}$
13. If it does not, adjust it by rotating the potentiometer shaft by 180 degrees or replacing the potentiometer shaft.

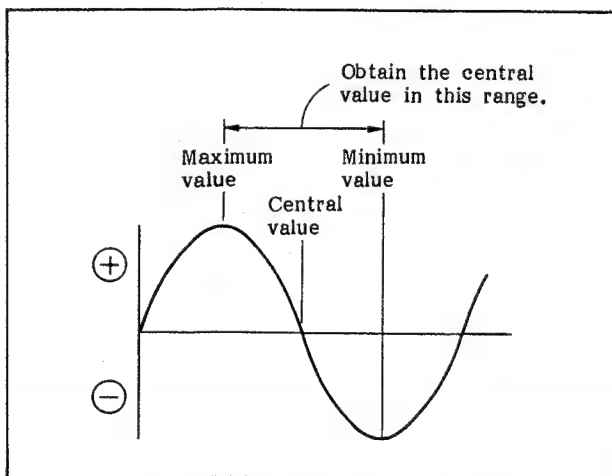

Fig. 9-6-2 Indicated Value of the Digital Voltmeter

Fine adjustment

14. Loosen the two set screws (+PSW 3 x 8) that hold the tension regulator by one or two turns and then push the arm shaft of the tension regulator against the tension adjustment tool. (Fig. 9-6-1)
15. Adjust so that the indicated value of the digital voltmeter satisfies the following specification by inserting the screwdriver in the groove, shown in the top view of Fig. 9-6-1, and rotating it. If the adjustment cannot be made, repeat Steps 4 through 15.

Standard: Central value (V) $\pm 50\text{mV}$

16. Tighten the two set screws (+PSW 3 x 8) after the adjustment. Check again that the indicated value of the digital voltmeter satisfies the specification. If it does not, loosen the two set screws and make the adjustment again. When it does, remove the digital voltmeter.
17. Press the **[F5]** (E), **[F2]** (B) and **[SET]** keys on the control panel in that order to indicate the tension regulator output on the display of the control panel.

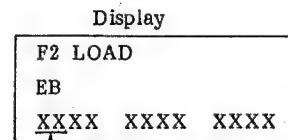

Output value of the tension regulator

18. Press the **[F7]** (\$), **[F7]** (\$), **[F1]** (A), **[8]**, **[9]**, **[0]** and **[SET]** keys on the control panel in that order. The following message will be displayed.

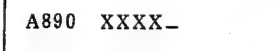

19. Push the arm shaft of the tension regulator against the tension adjustment tool, as shown in the top view of Fig. 9-6-1.
20. Change the current data until the output value of the tension regulator satisfies the following specification.

Standard: 51 - 55

When the output value is small, increase the value of the data, and when it is large, decrease it. When it satisfies the specification, press the **[SET]** key.

21. Press the **F10** (NVW) and **SET** keys on the control panel. Press the **/** key and hold it down until "PUSH NVWR SW" is indicated on the display. When "PUSH NVWR SW" is displayed on the display, press the SW2 (NVWR) on the SP-01 board. Check that "READY" is indicated on the display.
22. Remove the tension adjustment tool.

30 g weight adjustment

23. Place the hole of the roller of the tension adjustment tool over the pin of the S plate assembly and fix them with one set screw (+P3x6). (Fig. 9-7)
 24. Place the tension adjustment tool with its 30 g weight on the S4 guide and set the tape portion as shown in Fig. 9-8, then press the string over the roller.
 25. Check to see that the weight (30 g) does not touch other parts. Lift the weight 2 to 3 mm by hand, and then, drop it. Repeat this action three times.
 26. Loosen the set screw (+PS 2.6 x 6) shown in the top view of Fig. 9-8 for 1/4 to 1/2 turn, then adjust the output value of the tension regulator by turning the adjusting top so that it becomes the following standard.
- Standard: 4E - 58**
27. Tighten the loosened set screw (+PS 2.6 x 6), then check to see that the output value of the tension regulator meets the standard. If it does not, go back to Step 24 and adjust it again.
 28. Remove the weight of the tension regulator and apply adhesives to the head of the tightened set screw.

70 g weight adjustment

29. Place the tension adjustment tool with its 70 g weight on the S4 guide and set the tape portion as shown in Fig. 9-9, then pass the string over the roller.
 30. Check to see that the weight (70 g) does not touch other parts. Lift the weight 2 to 3 mm by hand, and then, drop it. Repeat this action three times.
 31. Check to see that the output value of the tension regulator meets the following standard. If it does not, repeat the procedure from Step 24. If it still does not meet the standard even after readjustment, perform the gain adjustment described below, or replace the spring shown in the top view of Fig. 9-8, then repeat the procedure from Step 24.
- Standard: A2 - B6**

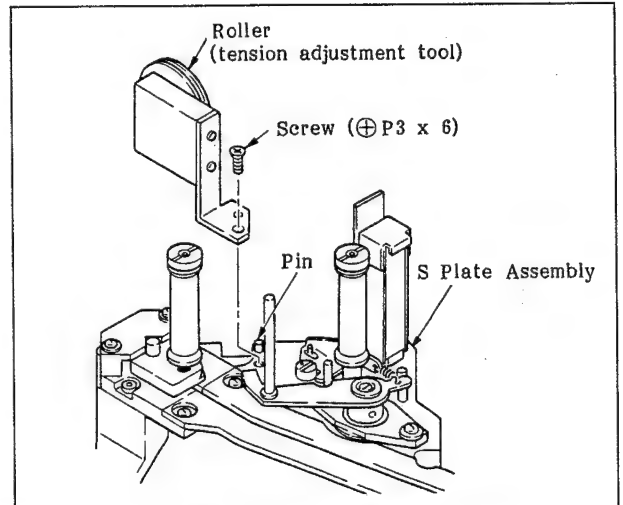

Fig. 9-7 Installation of the Roller

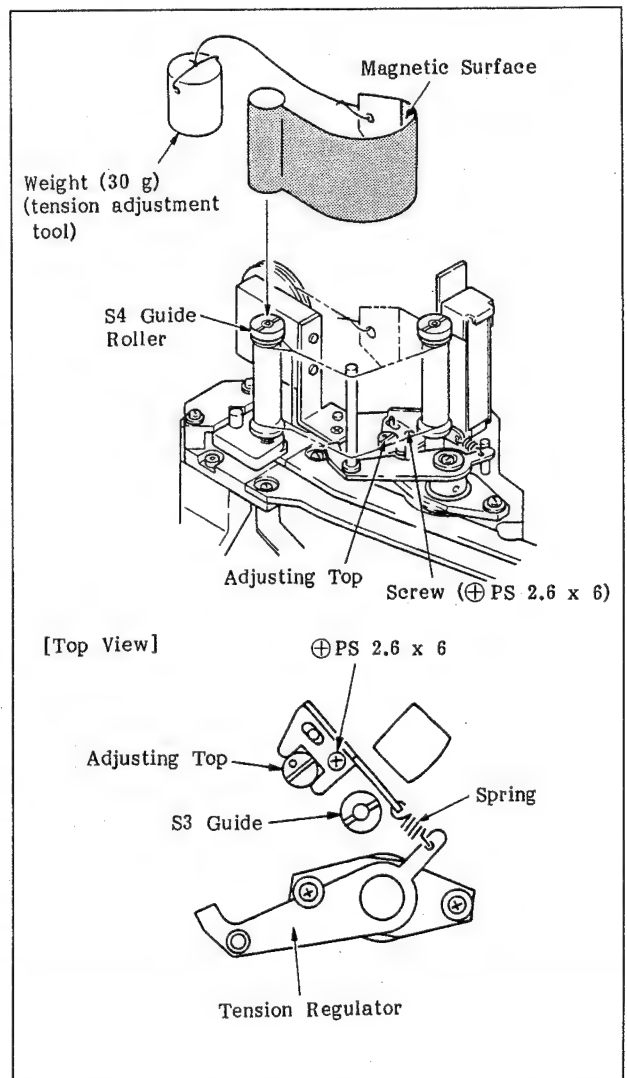

Fig. 9-8 Adjustment of the Tension Using a 30g Weight

Gain adjustment

- Place the tension adjustment tool with its 70g weight on the S4 guide and press the **TEST**, the **F3** (CHECKER), the **F1** (CONTINUE), the **F7** (\$), the **F1** (A), the **8**, the **9**, the **2**, and the **SET** keys on the control panel in that order. The data is indicated on the display as shown below.

```
A892 XX_
      ↑ Current data
```

- Input a byte data that has been changed approximately $\pm 10H$ in the current data, then press the **BS** key. Repeat this procedure until the output value of the tension regulator becomes the following standard. When it does, press the **SET** key.

Standard: A2 - B6

When the output value is larger than B6, increase the value of the data, and when it is smaller than A2, decrease the value of the data. When the following specification is met, press the **SET** key.

- Perform Steps 24 and 25. Then, perform Step 26 and confirm that the output value meets the standard. If it does, go to step (7). If it does not, perform the following step.
- Press the **F7** (\$), the **F7** (\$), the **F1** (A), the **8**, the **9**, the **0**, and the **SET** keys on the control panel in that order. The data is indicated on the display as shown.

```
A890 XXXX_
      ↑ Current data
```

- After inputting a word data that has been changed approximately $\pm 1000H$ in the current data, press the **BS** key. Repeat this procedure until the output value of the tension regulator meets the following standard. When it does, press the **SET** key.

Standard: 4E - 58

- Perform Steps 29 and 30. Then, perform Step 31 and confirm that the output value meets the standard. If it does not, repeat the procedure from Step ① .

- Press the **F10** (NVW) and the **SET** keys on the control panel in that order. Keep pressing the **/** key until "PUSH NVWR SW" is displayed. The addresses that might be indicated before "PUSH NVWR SW" is displayed are:

A890 XX-XX, A891 XX-XX (These addresses might be displayed when Steps ④ , ⑤ , and ⑥ are performed.) A892 XX-XX, A8FE XX-XX, A8FF XX-XX

Check to see that other than these addresses are not displayed. Then, press SW2(NVWR) on the SP-01 board. Confirm that "READY" is indicated on the display.

- Remove the weight and the roller that were set in Step 23.

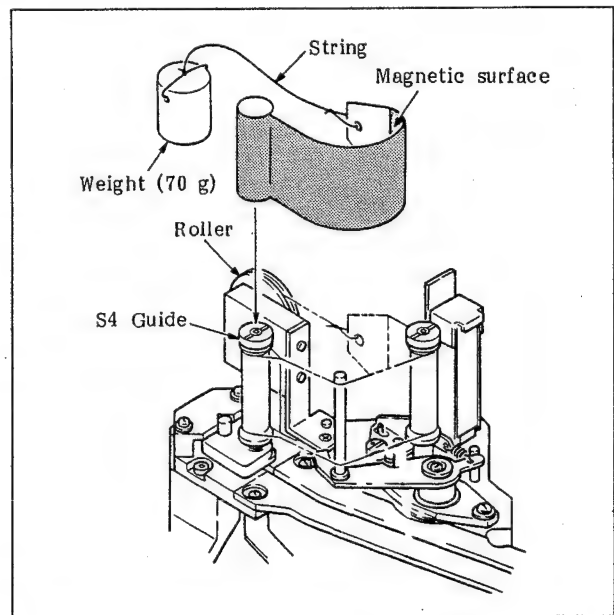

Fig. 9-9 Adjusting the Tension Using a 70 g Weight



9-4. TAPE SPEED ADJUSTMENT

Background knowledge

- A. The tape speed of REC mode is adjusted here.
- B. This adjustment is required only when the tape speed is not normal or when the capstan motor is replaced.
- C. Use the following alignment tape for making the adjustments.
 - . Alignment Tape: 8-960-070-01 (525/60)
 - 8-960-070-51 (625/50)

Confirmation and adjustment

1. Turn on the power and then playback the alignment tape.
2. Press the **TEST**, the **F3** (CHECKER), the **F1** (CONTINUE), **F3** (C), the **F2** (B), the **SET**, the **F7** (\$), and the **SET** keys on the control panel in that order.
3. Adjust the value indicated at the place on the display of the upper portion of Fig. 9-10 marked by X by using the **<** or **>** key so that it fluctuates around 0000.
4. When the optimum value is obtained, press the **SET** key.
5. Set the unit in STOP mode, then press the **EJECT** key and remove the cassette.

Note: Make sure not to turn the power off at this time.
6. Press the **F10** (NVW) and the **SET** keys on the control panel in that order. Then, keep pressing the **/** key until "PUSH NVWR SW" is indicated on the display. The addresses that might be indicated before "PUSH NVWR SW" is displayed are: "A8C0 XX-XX", "A8FE XX-XX", "A8FF XX-XX"
Check to see that other than these addresses are not displayed.
7. Press SW2(NVWR SW) on the SP-01 board.
8. Check to see that "READY" is displayed.

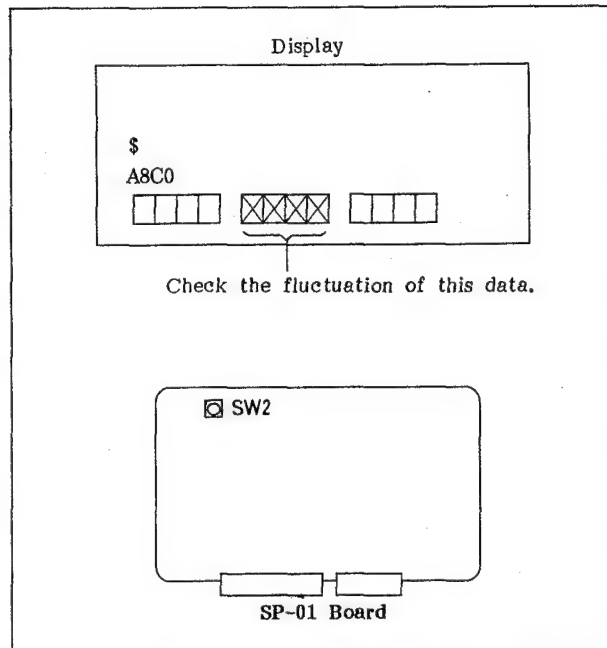

Fig. 9-10 Tape Speed Adjustment

9-5. TRACKING ADJUSTMENT

9-5-1. Tracking Check

Background knowledge

- A. In case the scanner assembly has been replaced, before performing the tracking check, make sure to perform a running-in operating in REC mode for about 20 minutes to improve the contact condition of the head and tape.
- B. Prepare the following alignment tape for this adjustment.
 - . Alignment tape: 8-960-070-01 (for 525/60)
 - 8-960-070-51 (for 625/50)
 - . BNC-UM cable: J-6264-360-A
1. Connect an oscilloscope to TP8 (Ach) of the RF-15 board, and connect TP6 (PG pulse) of the CD-35 board to the scope as the trigger input with the BNC-UM cable.
2. Thread the alignment tape.
3. Press the **TEST**, the **F2** (RF) and the **F1** (CONTINUE) keys on the control panel in sequence.
4. Check to see that "<<Test: RF VARIABLE MODE>>" is displayed. If it is displayed, set the machine in the RF VARIABLE MODE by pressing the **F1** (VAR) Key.
5. Press the **F7** (PB EQUALIZE CH.A), the **F8** (AGC), the **F8** (AGC) Keys on the control panel in sequence, and check to see that the AGC Of CH.A is set to OFF.
6. Play back the tape path adjustment portion of the alignment tape.
7. Make sure that the tape contacts the upper flange of the S2 and T2 guides slightly and curls very little. If these conditions are not satisfied, perform the adjustment section first.
8. Adjust the RF amplitude until it becomes maximum by turning the tracking knob.
9. Make sure that the RF waveform satisfies the standard shown in Fig. 9-11. If it does not, perform the adjustment section first. Make sure that the upper and lower envelopes of the RF waveform are parallel each other when the tracking knob is turned back and forth. If it does not, perform the tracking adjustment.
10. Adjust the RF amplitude until it becomes maximum again by turning the tracking knob. Then, push the tracking knob in, making sure that the RF waveform does not change at this time. If it does, perform the CTL head position adjustment.
11. Press the **F8** (AGC) Key so that the AGC is set to ON.

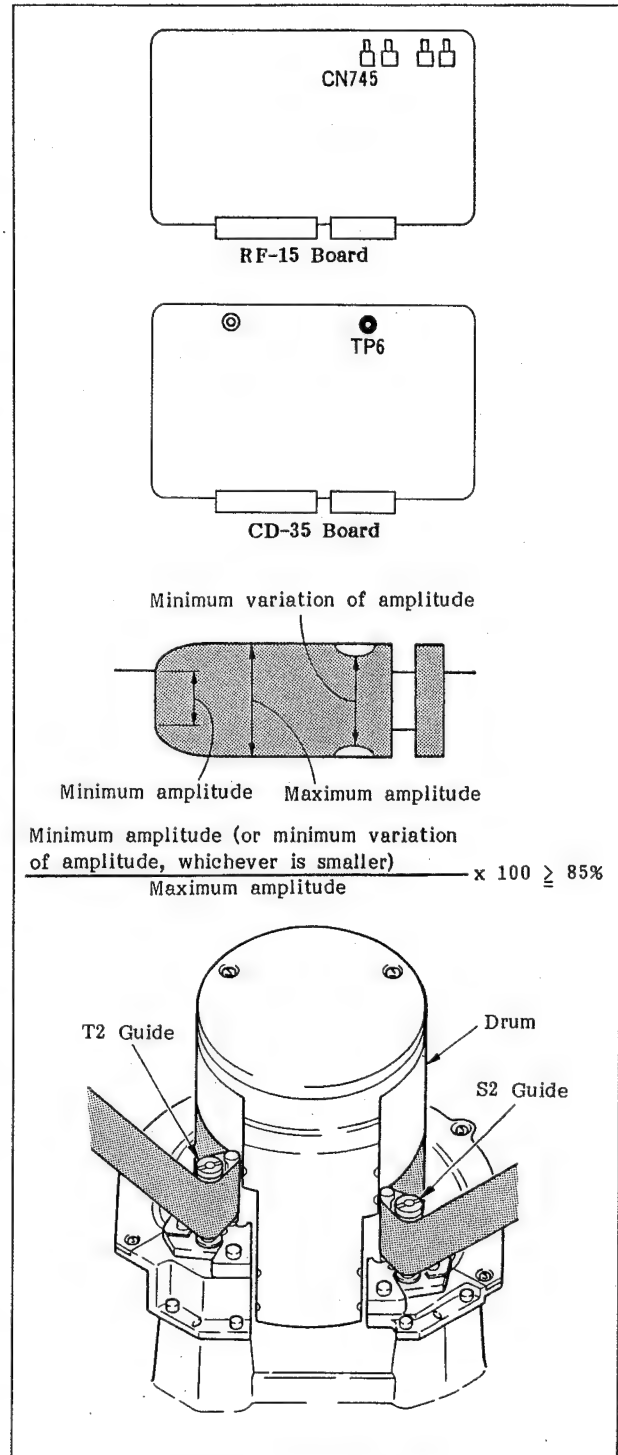

Fig. 9-11 Tracking Check

9-5-2. Tracking Adjustment

Background knowledge

- A. The purpose of this adjustment is to ensure the compatibility of the recorded tape by adjusting the contact of the head with the tape correctly so that the head traces the recorded pattern of the alignment tape properly.
- B. Use an alignment tape that is not wrinkled along the edges or scratched.
- C. Tracking is checked with the RF waveform and its adjustment is mainly performed as follows.

The waveform at the tape entrance side is adjusted by changing the inclination of the entrance slant guide and the height of the S2 guide.

The waveform at the tape exit side is adjusted by changing the inclination of the exit slant guide and the height of the T2 guide.

D. Points for adjustment

- ① Before adjusting the inclination of the entrance and exit slant guides, check the direction to move the guide by pushing it slightly with your finger.
- ② Refer to the drawing for the relation of the direction of the rotation and inclination of the inclination adjusting screws of the slant guides.
- ③ Use a hexagon wrench (opposite side: 1.5 mm) for the adjusting screws.
- ④ The inclination adjusting screws (a) and (b), and (c) and (d), should be adjusted at the same time.

Preparation before adjustment

1. Connect an oscilloscope to CN745 (Ach) of the RF-15 board with the BNC-UM cable, and connect TP6 (PG pulse) of the CD-35 board to the scope as the trigger input.
2. Thread the alignment tape.
3. Press the **[TEST]**, the **[F2](RF)** and the **[F1](CONTINUE)** keys on the control panel in sequence.
4. Check to see that "<<Test: RF VARIABLE MODE>>" is displayed. If it is displayed, set the machine in the RF VARIABLE MODE by pressing the **[F1](VAR)** Key.
5. Press the **[F7](PB EQUALIZE CH.A)**, the **[F8](AGC)**, the **[F8](AGC)** keys on the control panel in sequence, and check to see that the AGC of CH.A is set to OFF.
6. Play the tape path adjustment portion of the alignment tape.
7. Adjust the RF amplitude until it becomes approximately 4/5 of the maximum value by turning the tracking knob.

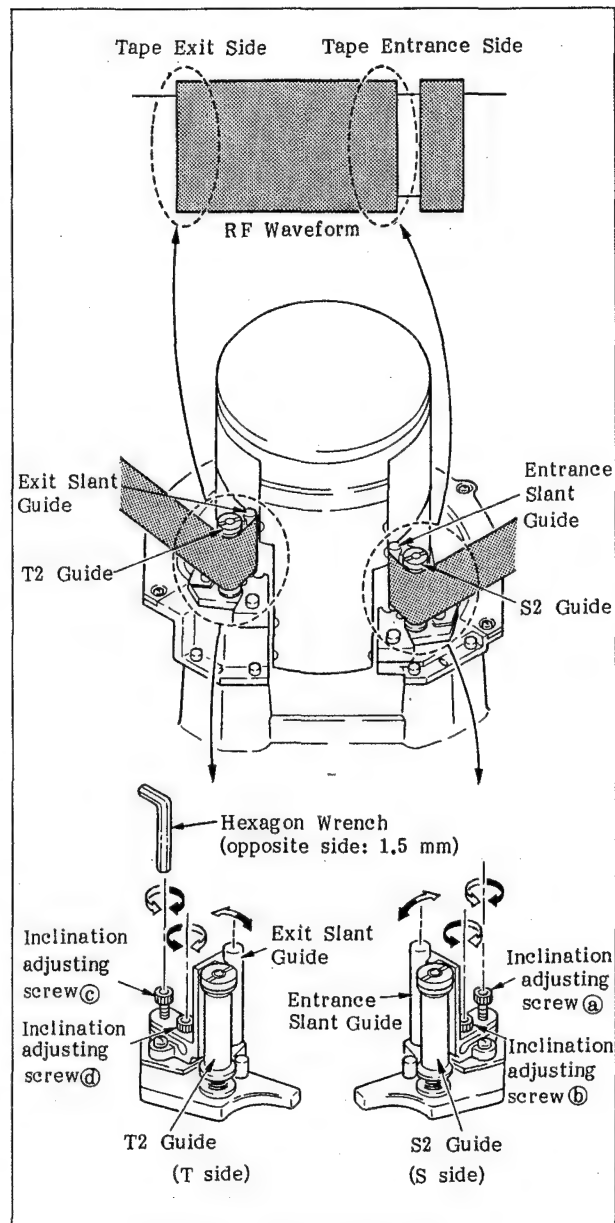

Fig. 9-12 Tracking Adjustment

Adjustments of the height of the S2 guide and the inclination of the entrance slant guide

8. Loosen the set screw in the upper portion of the S2 guide.
9. Adjust the RF waveform of the tape entrance side until it becomes flattest by turning the flange holder of the S2 guide with a flatblade screwdriver.
10. Tighten the set screw with a torque of approximately 3 to 4 kg-cm.
11. Make sure that the tape touches the upper flange of the S2 guide, but does not curl. If it curls, repeat the procedure from Step 8.
12. If the RF waveform does not become flat by adjusting the height of the S2 guide, perform the following inclination adjustment.
13. Find the place where the RF waveform becomes flat by pressing the portion (U) or (L) shown in the lower portion of Fig. 9-13.
14. If the RF waveform becomes flatter when the portion (L) is pressed, turn the inclination adjusting screws (a) and (b) in the A direction, and if the RF waveform becomes flatter when the portion (U) is pressed, turn the inclination adjusting screws (a) and (b) in the B direction to flatten the RF waveform and minimize the fluctuation.
15. Make sure that the upper and lower envelopes of the RF waveform at the tape entrance side are parallel each other when the tracking knob is turned back and forth. If it does not, repeat the procedure from Step 8.
16. Make sure that the tape touches the upper flange of the S2 guide and does not curl. If these conditions are not satisfied, repeat the procedure from Step 8.

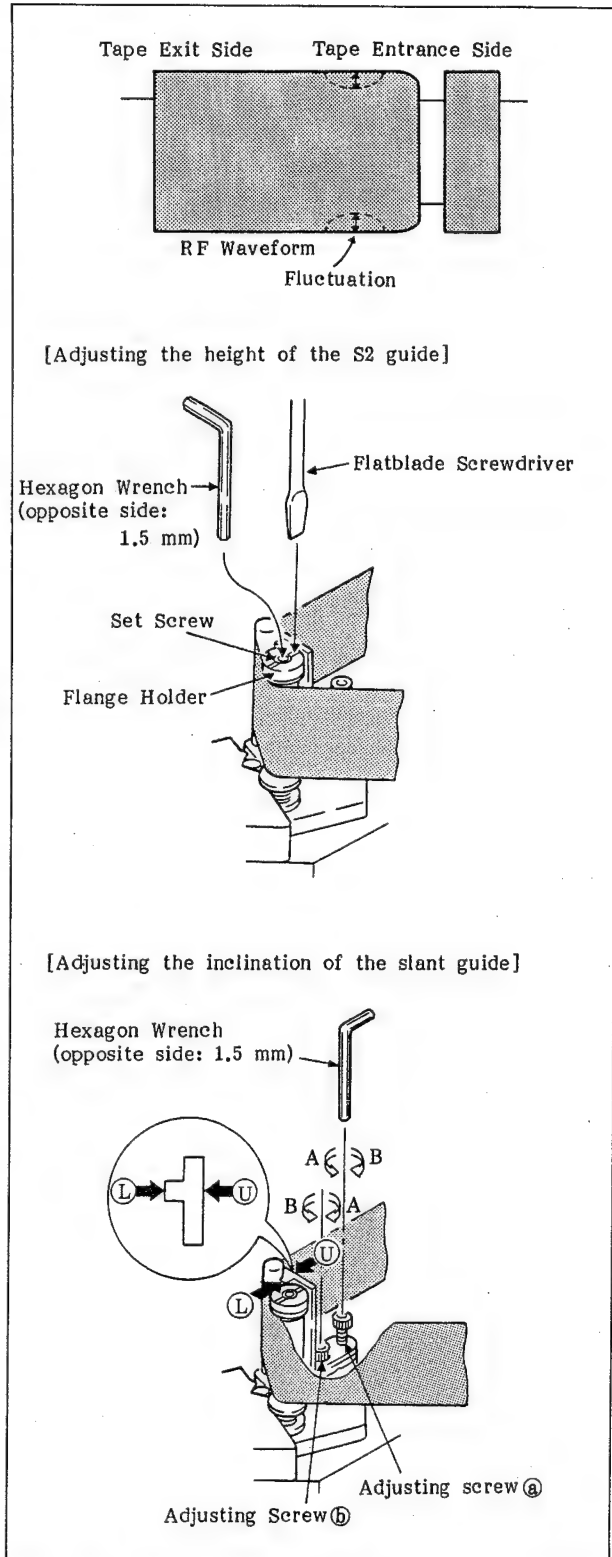

Fig. 9-13 Adjustments of the Height of the S2 Guide and the Inclination of the Entrance Slant Guide

Adjustments of the height of the T2 guide and inclination of the exit slant guide

17. Loosen the set screw of the upper portion of the T2 guide.
18. Adjust the RF waveform of the tape exit side by turning the flange holder of the T2 guide with a flatblade screwdriver so that it becomes flattest.
19. Tighten the set screw with a torque of approximately 3 to 4 kg-cm.
20. Confirm that the tape touches the upper flange of the T2 guide, but does not curl. If it curls, repeat the procedure from Step 17.
21. If the RF waveform does not become flat by adjusting the height of the S2 guide, perform the following inclination adjustment.
22. Find the place where the RF waveform becomes flat by pressing the portion (U) or (L) shown in the lower portion of Fig. 9-13.
23. If the RF waveform becomes flatter when the portion (L) is pressed, turn the inclination adjusting screws (c) and (d) in the direction of B, and if the RF waveform becomes flatter when the portion (U) is pressed, turn the inclination adjusting screws (c) and (d) in the direction of A to flatten the RF waveform and minimize the fluctuation.
24. Make sure that the upper and lower envelopes of the RF waveform at the tape exit side are parallel each other when the tracking knob is turned back and forth. If it does not, repeat the procedure from Step 17.
25. Make sure that the tape touches the upper flange of the T2 guide and does not curl. If these conditions are not satisfied, repeat the procedure from Step 17.
26. Set AGC to ON by performing steps 3 and 5.

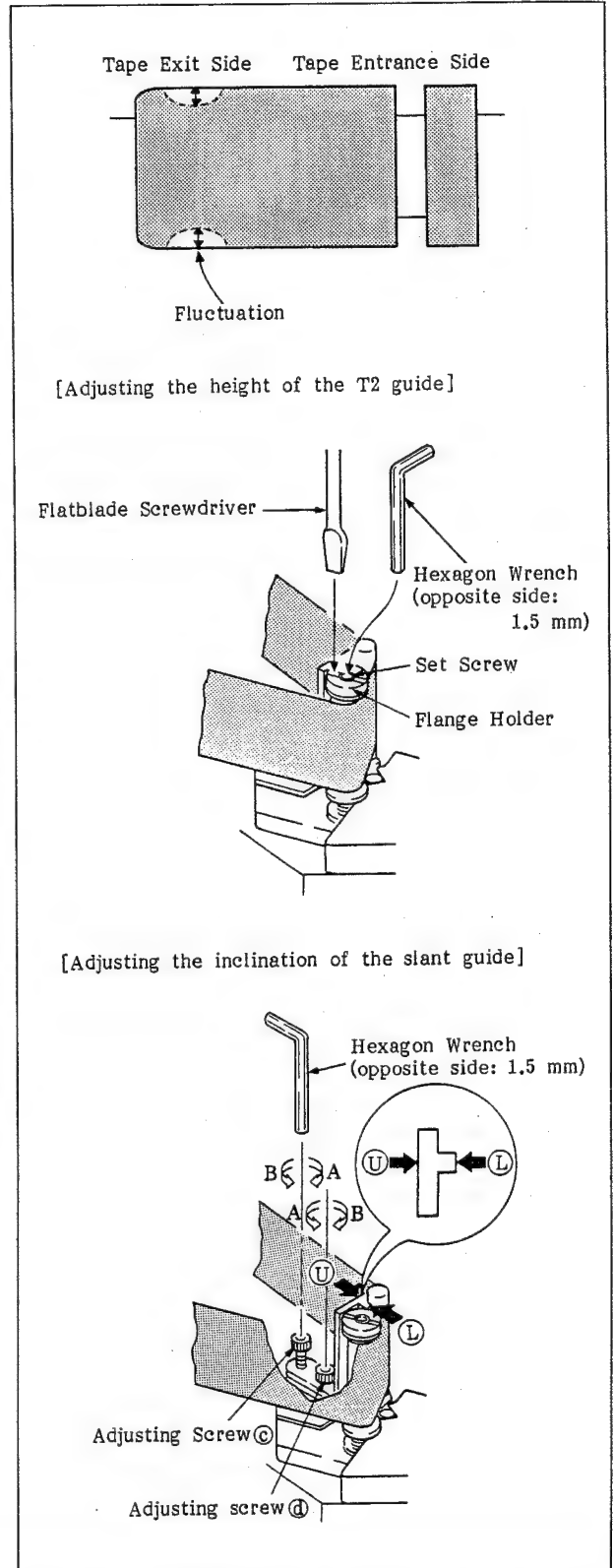

Fig. 9-14 Adjustments of the Height of the T2 Guide and the Inclination of the Exit Slant Guide

9-6. STATIONARY HEAD HEIGHT ADJUSTMENT

1. Connect an oscilloscope to TP306 on the AE-05 board.
2. Play back the tape path adjustment portion of the alignment tape.
3. Loosen the height locking screw.
4. Turn the height adjusting screw until the waveform displayed on the oscilloscope becomes maximum. Then, turn it counterclockwise from that position (in the direction to raise the height of the head) and stop turning it just before the waveform drops.
5. Tighten the height locking screws.
6. Set the unit in STOP mode, press the 'EJECT' button, and remove the tape.

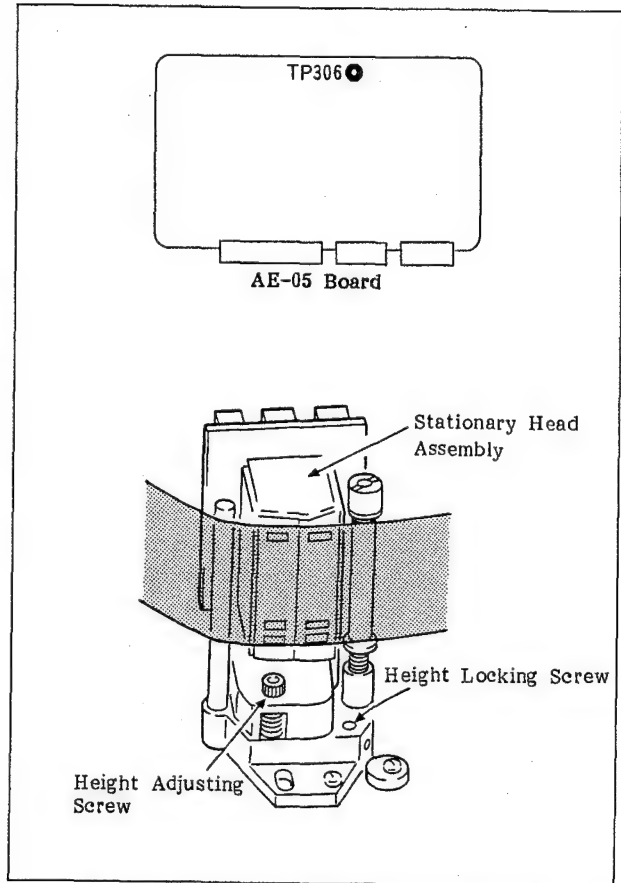

Fig. 9-15 Stationary Head Height Adjustment

9-7. CTL HEAD POSITION ADJUSTMENT

Background knowledge

- A. If the CTL head is not installed in the proper position, a tape recorded by another machine may not play back satisfactorily.
- B. If the CTL head is moved, the PG phase changes greatly. Always adjust the PG phase whenever the CTL head position is adjusted.

Adjustment

1. Connect CN745 (A ch) on the RF-15 board and the oscilloscope with an BNC-UM cable and connect TP3 (FRAME pulse) on the SP-01 board as the trigger input.
2. Thread the alignment tape.
3. Press the **TEST**, the **F2** (RF) and the **F1** (CONTINUE) keys on the control panel in sequence.
4. Check to see that "<<Test: RF VARIABLE MODE>>" is displayed. If it is displayed, set the machine in the RF VARIABLE MODE by pressing the **F1** (VAR) key.
5. Press the **F7** (PB EQUALIZE CH.A), the **F8** (AGC), the **F8** (AGC) keys on the control panel in sequence, and check to see that the AGC of CH.A is set to OFF.
6. Play back the CTL head position adjusting section (0 min. 00 sec. to 2 min. 00 sec.) of the alignment tape.
7. Loosen the screw A, shown in the top view of Fig.9-16, which is one of the two screws that hold the stationary head assembly, and the set screw of the AU stopper.
8. Set the tracking knob in FIX status.
9. Adjust the RF amplitude until it becomes maximum by inserting an eccentric screwdriver in the adjusting hole and turning it.
10. Tighten the two screws of the stationary head assembly securely.
11. Set the tracking knob in VAR status and adjust the RF amplitude until it becomes maximum.
12. Check to see that the RF amplitude does not change when the tracking knob is changed from VAR status to FIX status when the RF amplitude becomes maximum. If it changes, loosen the two screws that fix the stationary head assembly, and then, repeat the procedure from Step 9.
13. Push the AU stopper against the stationary head assembly by rotating it clockwise and then tighten the set screws. Set the machine in STOP mode.
14. Press the **F8** (AGC) key on the control panel to turn on AGC of CH.A.
15. Press the **EJECT** button to remove the alignment tape.

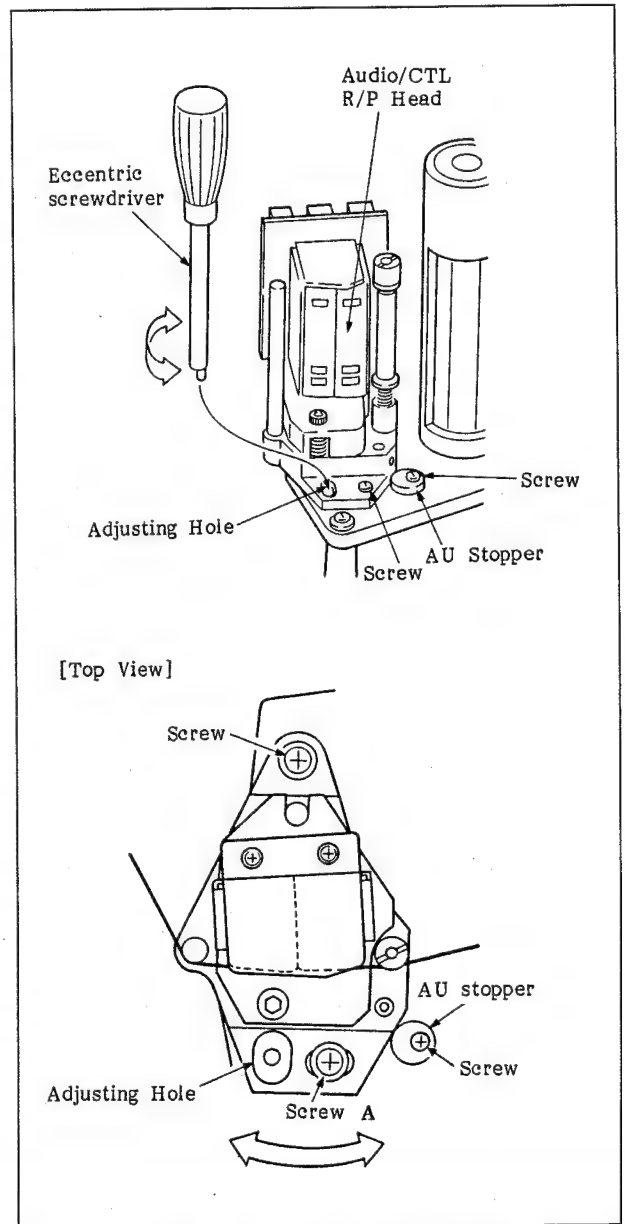

Fig. 9-16 CTL Head Position Adjustment

9-8. PG PHASE ADJUSTMENT

Background knowledge

It is necessary to adjust the PG phase to match the timing of the drum rotation and the DVPC-1000 signal processing.

Confirmation and Adjustment

1. Connect the CN-A and the CN-B connectors of DVR-1000 and DVPC-1000, with the specified cables.
2. Turn the power on and thread the alignment tape.
3. Connect TP-3 on the TG-28 board of the DVPC-1000 and CN745(CH.A) on the RF-15 board to the oscilloscope with the BNC-UM cable.
4. Press the **TEST**, the **F2** (RF) and the **F1** (CONTINUE) keys on the control panel in sequence.
5. Check to see that "<<Test: RF VARIABLE MODE>>" is displayed. If it is displayed, set the machine in the RF VARIABLE MODE by pressing the **F1** (VAR) Key.
6. Press the **F7** (PB EQUALIZE CH.A), the **F8** (AGC), the **F8** (AGC) keys on the control panel in sequence, and check to see that the AGC of CH.A is set to OFF.
7. Play back the PG phase adjusting section (8 min. 00 sec. to 10 min. 00 sec.) of the alignment tape.
8. Press the **TEST**, the **F3** (CHECKER), the **F1** (CONTINUE), the **F3** (C), the **9**, the **F7** (\$), the **F7** (\$), and the **SET** keys on the control panel in that order. Then, adjust the RF waveform displayed on the oscilloscope so that it meets the standard shown in the figure by pressing the **<** or the **>** key.
9. When an appropriate data is found, press the **SET** key to set the machine in STOP mode.
10. Press the **F10** (NVW) and the **SET** keys on the control panel in that order. Then, keep pressing the **∏** key until "PUSH NVWR SW" is displayed. The addresses that might be indicated before "PUSH NVWR SW" is displayed are: "A8D0 XX-XX", "A8D1 XX-XX", "A8D2 XX-XX", "A8FE XX-XX", "A8FF XX-XX"
Check to see that other than these addresses are not displayed.
11. Press SW2(NVWR SW) on the SP-01 board.
12. Check to see that "READY" is displayed.
13. Set the AGC to CN by performing steps 4 through 6.
14. Press the **EJECT** button and remove the cassette.

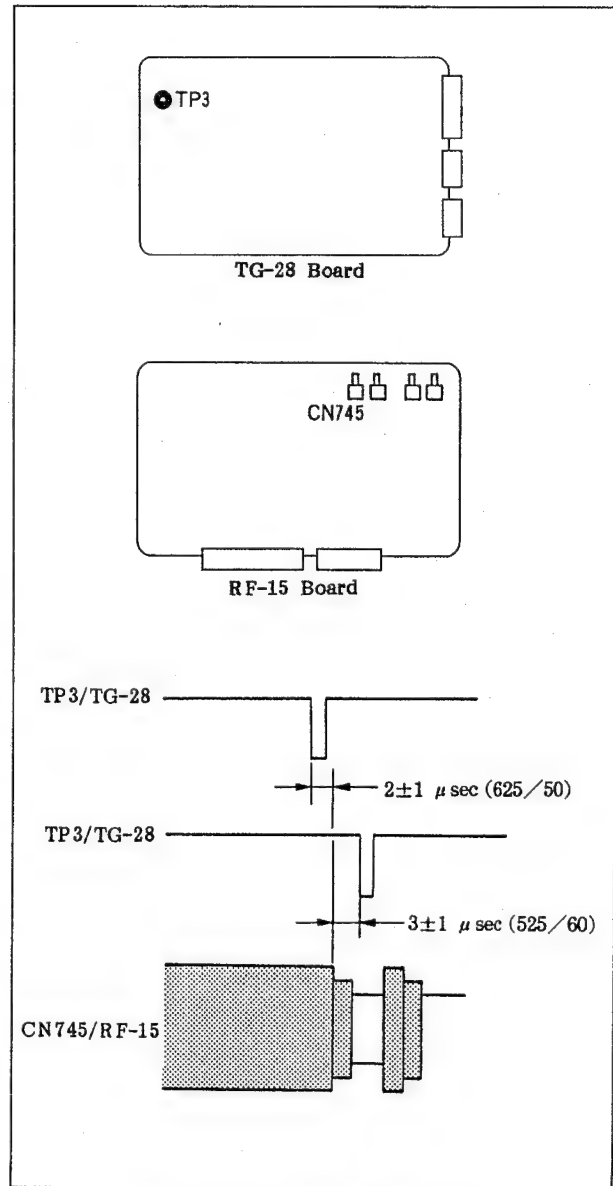

Fig. 9-17 PG Phase Adjustment

9-9. CTL HEAD POSITION CHECK

Background knowledge

When the amount of the PG phase adjustment is large, the position of the CTL head may shift. It is necessary to check the position of the CTL head when the adjustments of the PG phase are made.

CTL head position check 1

1. Connect the CN-A and CN-B connectors of DVR-1000 and DVPC-1000 with the specified cable.
2. Connect CN745 (A ch) on the RF-15 board and an oscilloscope with a BNC-UM cable and connect TP3 (FRAME pulse) on the SP-01 board as a trigger input.
3. Thread the alignment tape.
4. Press the **TEST**, the **F2** (RF) and the **F1** (CONTINUE) keys on the control panel in sequence.
5. Check to see that "<<Test: RF VARIABLE MODE>>" is displayed. If it is displayed, set the machine in the RF VARIABLE MODE by pressing the **F1** (VAR) key.
6. Press the **F7** (PB EQUALIZE CH.A), the **F8** (AGC), the **F8** (AGC) keys on the control panel in sequence, and check to see that the AGC of CH.A is set to OFF.
7. Play back the CTL head position adjusting section (0 min. 00 sec. to 2 min. 00 sec.) of the alignment tape.
8. Set the tracking control to VAR and maximize the RF amplitude. Check that the RF amplitude does not change even if the tracking control is set to FIX. If it changes, repeat the adjustments from step 7 in Section 9-7 "CTL Head Position Adjustment". If it does not change, perform CTL Head Position Check 2.

CTL head position check 2

9. Set the tracking control to FIX and play back the CTL head position adjusting section (0 min. 00 sec. to 2 min. 00 sec.) of the alignment tape. Check that the phases of CN745/RF-15 and TP3/SP-01 satisfy the specifications, shown in the figure.
10. If it does not, set the machine to STOP mode and press the **EJECT** button to remove the cassette. Then repeat the adjustments in section 9-10 "Pre-PG Phase Adjustment".

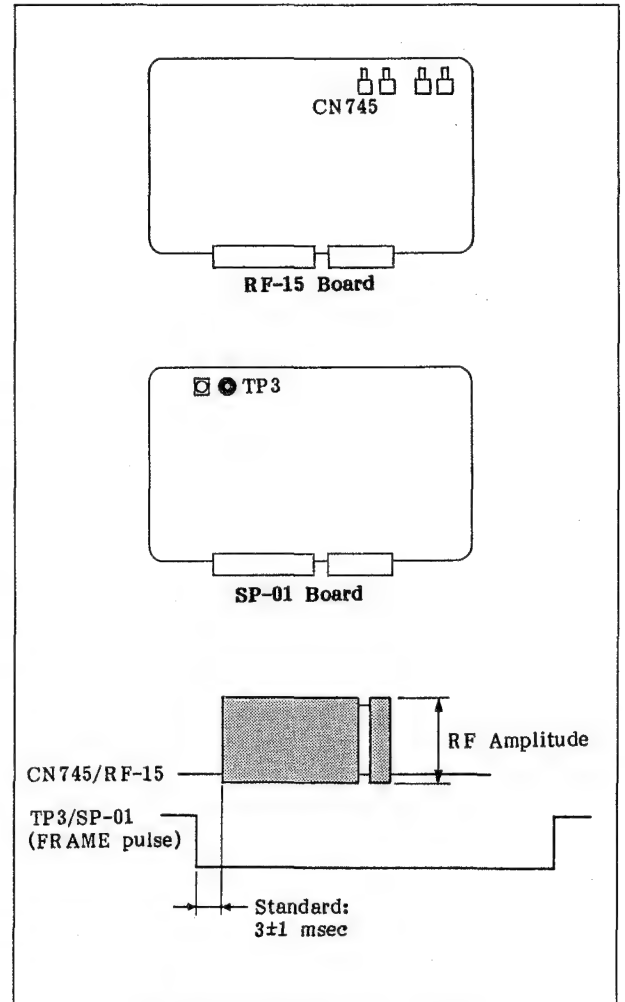

Fig. 9-18 CTL Position Check

9-10. PRE-PG PHASE ADJUSTMENT

Background knowledge

The PG coil and REC 1ch of the rotary head of the drum are positioned within a deviation of ± 10 degrees.

1. Connect the CN-A and CN-B connectors of DVR-1000 and DVPC-1000 with the specified cable and then turn on the power.
2. Loosen the screws which secure the AU stopper and stationary head assembly. Adjust the position of screw 'A' shown in the top view of Fig. 9-16 by inserting an eccentric screwdriver into the adjusting slot and turning the screwdriver so that screw 'A' comes to the center of the slot.
3. Tighten the screws which secure the stationary head assembly.
4. Turn the AU stopper clockwise until it touches the stationary head assembly, then tighten the fixing screw.
5. Connect CN745 (A ch) on the RF-15 board and an oscilloscope with a BNC-UM cable and connect TP3 (FRAME pulse) on the SP-01 board as a trigger input.
6. Thread the alignment tape.
7. Press the **TEST**, the **F2** (RF) and the **F1** (CONTINUE) keys on the control panel in sequence.
8. Check to see that "<<Test: RF VARIABLE MODE>>" is displayed. If it is displayed, set the machine in the RF VARIABLE MODE by pressing the **F1** (VAR) key.
9. Press the **F7** (PB EQUALIZE CH.A), the **F8** (AGC), the **F8** (AGC) keys on the control panel in sequence, and check to see that the AGC of CH.A is set to OFF.
10. Set the tracking control to FIX and playback the CTL position adjusting section (0 min. 00 sec. to 2 min. 00 sec.) of the alignment tape.
11. Press the **TEST**, the **F3** (CHECKER), the **F1** (CONTINUE), the **F7** (\$), the **F1** (A), the **8**, the **F4** (D), the **0** and the **SET** keys on the control panel in that order.
12. Adjust the the phases of CN745/RF-15 and TP3/SP-01 so that they satisfy the specifications shown in Fig. 9-20 and the RF amplitude becomes maximum by pressing the **<** or the **>** key. When the specifications are met, press the **SET** key to set the machine in STOP mode.

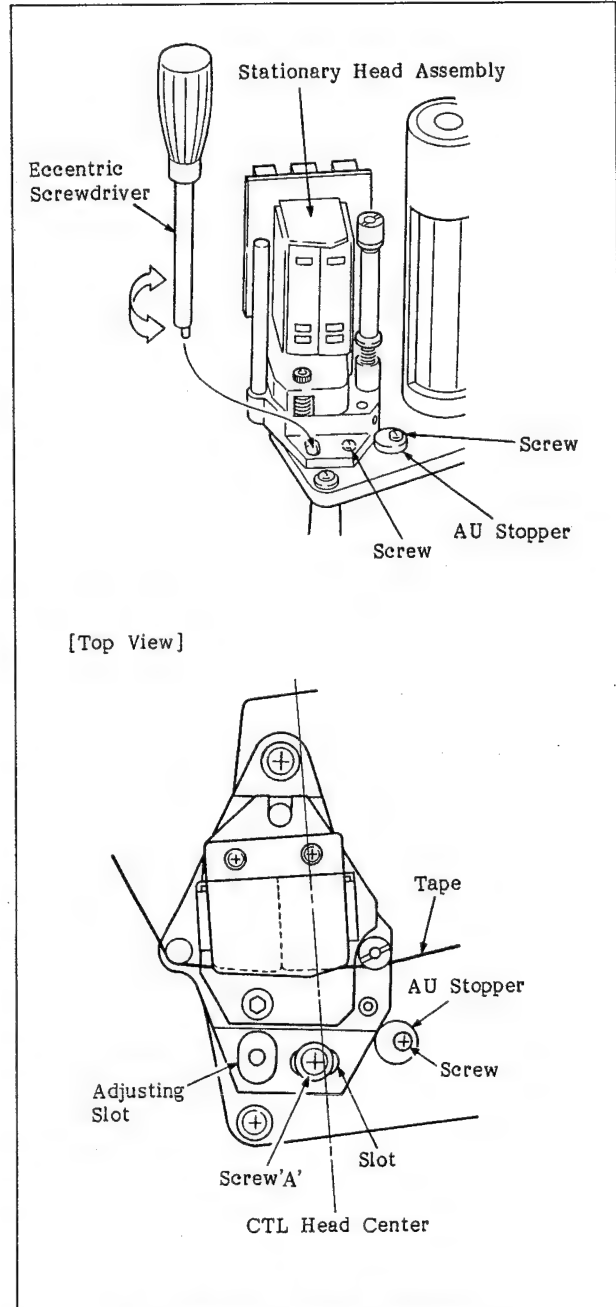

Fig. 9-19 Pre-PG Phase Adjustment (1)

13. Press the **F10** (NVW) and the **SET** keys on the control panel in that order, then keep pressing the **/** key until "PUSH NVWR SW" is displayed. The addresses that might be indicated before "PUSH NVWR SW" is displayed are: "A8D0 XX-XX", "A8FE XX-XX", "A8FF XX-XX"
Check to see that other than these addresses are not displayed.
14. Press SW2(NVWR SW) on the SP-01 board.
Check to see that "READY" is displayed.
15. Perform Steps 7 through 9 to turn on AGC.
16. Press the **EJECT** button and remove the cassette.

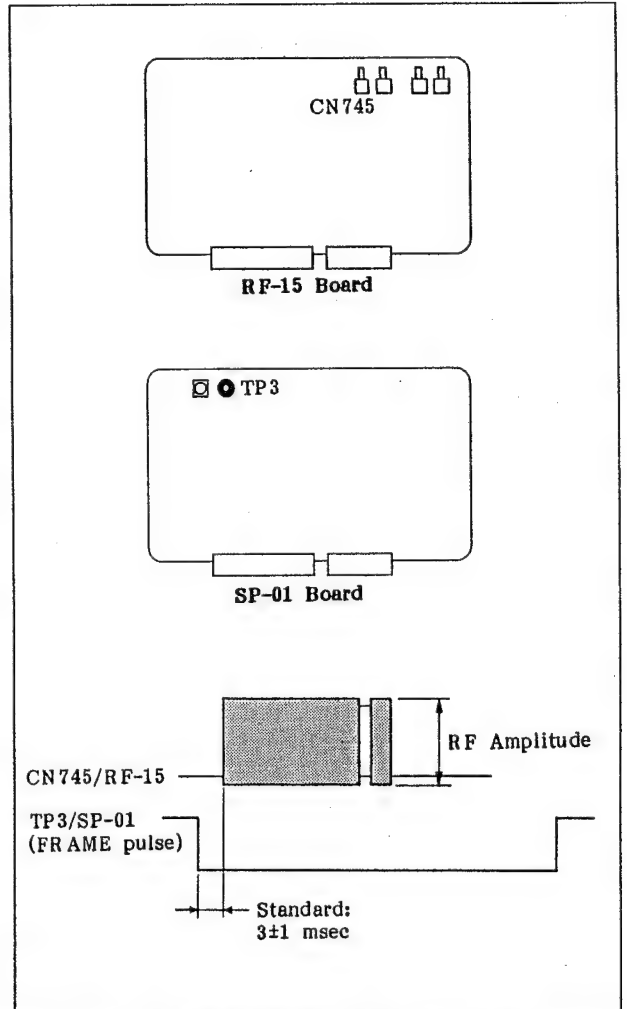

Fig. 9-20 Pre-PG Phase Adjustment (2)

9-11. CONF/ADVANCE HEAD HEIGHT ADJUSTMENT

Background knowledge

A. Do not adjust the height of the CONF Ach head. If the RF waveform when the tracking control of CONF Ach is set in FIX status does not match the maximum RF waveform, repeat the procedure from the CTL head position adjustment.

Note: All the adjustments has to be made again when A ch is moved because the CTL and PG positions are adjusted with the basis of A ch.

B. Pay careful attention when adjusting the RF waveform because it changes greatly with only a slight rotation of the adjusting screw.

1. Unscrew the two screws and remove the drum cover.
2. Connect CN745 (Ach) on the RF-15 board and TP306 (CTL PB) on the AE-05 board to the oscilloscope with the BNC-UM cable and connect TP3 (PG pulse) on the CD-35 board as the trigger input.
3. Thread the alignment tape.
4. Press the **TEST**, the **F2** (RF) and the **F1** (CONTINUE) keys on the control panel in sequence.
5. Check to see that "<<Test: RF VARIABLE MODE>>" is displayed. If it is displayed, set the machine in the RF VARIABLE MODE by pressing the **F1** (VAR) key.
6. Press the **F7** (PB EQUALIZE CH.A), the **F8** (AGC), the **F8** (AGC) keys on the control panel in sequence, and check to see that the AGC of CH.A is set to OFF.
7. Play back the tracking check portion of the alignment tape. Set the tracking control in VAR status and adjust the RF amplitude until it becomes maximum. Then, check to see that the RF amplitude or CTL pulse position does not change even if the tracking control is set to FIX status.
8. Perform the same check by connecting the oscilloscope to CN746 (Beh), to CN747 (Cch), and to CN748 (Dch).
9. If it changes, adjust the height of the corresponding CONF/ADVANCE head in the following procedure.

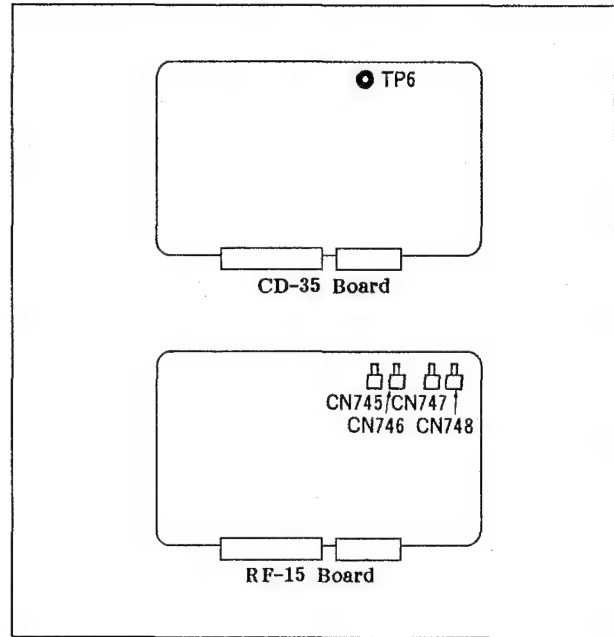

Adjustment

10. The arrangement of the rotary head is shown in the top view of Fig. 9-23.
11. Rotate the shaded portion with your finger so that the head to be adjusted matches the adjusting slot A.
12. Adjust the height of the scanner assembly with a flatblade screwdriver by inserting it into the height adjusting slot and rotating it as shown in the figure.

Note:

- . If the CTL pulse shifts to left when the tracking control is set to FIX, turn the flatblade screwdriver clockwise.
 - . If the CTL pulse shifts to right when the tracking control is set to FIX, turn the flatblade screwdriver counterclockwise.
13. Perform steps 6 to 8 to check the height of the head again.
 14. Fix the Drum cover with the two screws (+B3 x 8).
 15. Set the AGC to ON by pressing the **F8** (AGC) on the control panel.

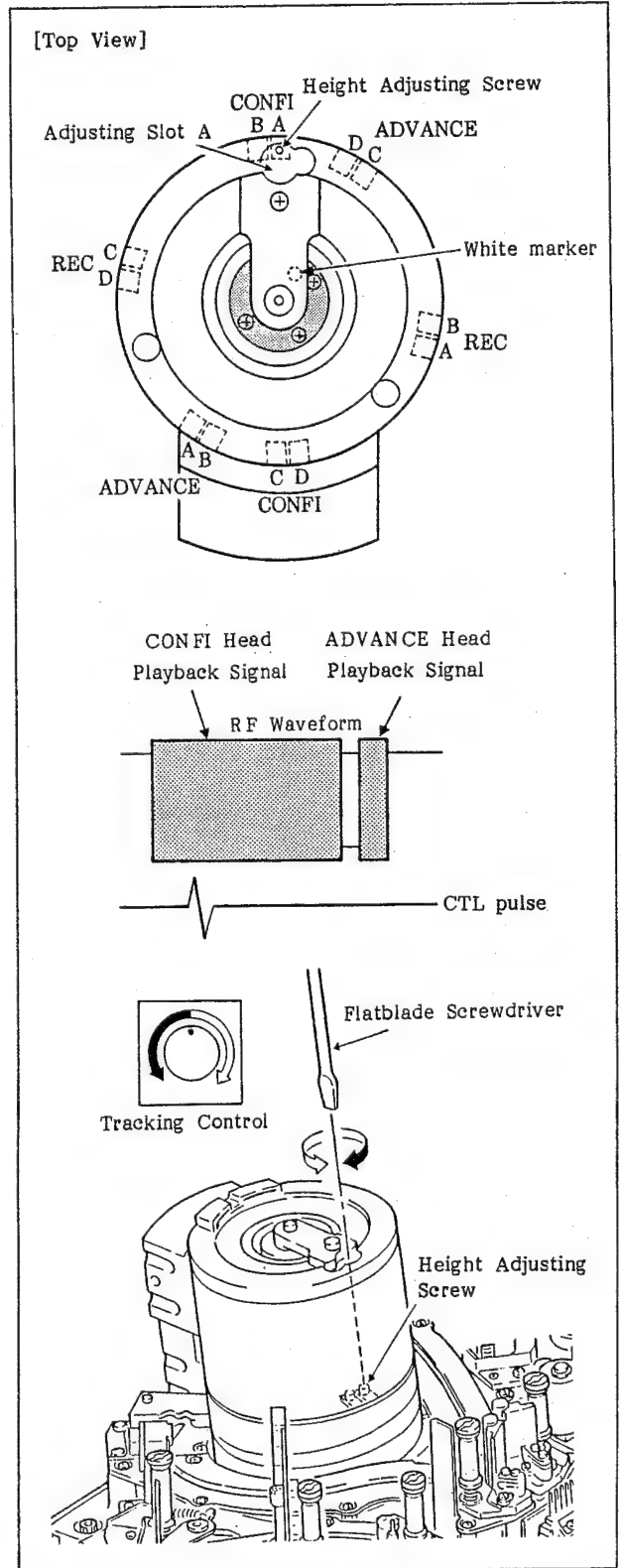

Fig. 9-21 CONF/ADVANCE Head Height Adjustment

9-12. REC HEAD HEIGHT ADJUSTMENT

Background knowledge

Pay careful attention when adjusting the RF waveform because it changes greatly with only a slight rotation of the adjusting screw.

1. Unscrew the two screws to remove the drum cover.
2. Connect CN745 (Ach) on the RF-15 board and TP306 on the AE-05 board to an oscilloscope with the BNC-UM cable and connect TP6 (PG pulse) on the CD-35 board as the trigger input.
3. Press the **TEST**, the **F2** (RF) and the **F1** (CONTINUE) keys on the control panel in sequence.
4. Check to see that "<<Test: RF VARIABLE MODE>>" is displayed. If it is displayed, set the machine in the RF VARIABLE MODE by pressing the **F1** (VAR) key.
5. Press the **F7** (PB EQUALIZE CH.A), the **F8** (AGC), the **F8** (AGC) keys on the control panel in sequence, and check to see that the AGC of CH.A is set to OFF.
6. Thread a commercially available cassette tape in the unit and record the video and audio signals.
7. Play back the recorded portion, then set the tracking control in VAR status and maximize the RF amplitude. Then, check that the RF amplitude or CTL pulse position does not change even if the setting of the tracking control is changed in FIX status.
8. Perform the same check by connecting the oscilloscope to CN746 (Bch), to CN747 (Cch), and to CN748 (Dch).
9. If the RF waveform changes, adjust the height of the REC head by the following procedure.

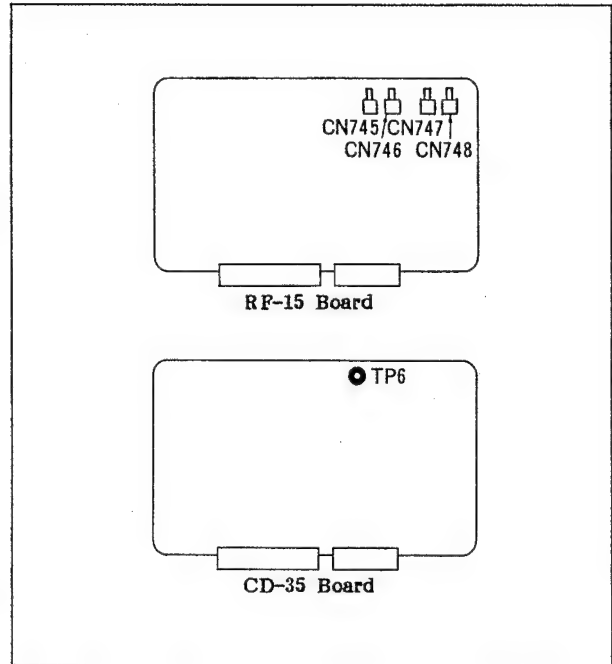

Adjustment

10. Arrangement of the rotary head is shown in the top view of Fig. 9-21.
11. Rotate the shaded portion with your finger so that the head to be adjusted matches the adjusting slot A.
12. Adjust the height of the scanner assembly with a flatblade screwdriver by inserting it into the adjusting slot A and turning the height adjusting screw.

Note:

- . If the CTL pulse shifts to left when the tracking control is set to FIX, turn the flatblade screwdriver counterclockwise.
- . If the CTL pulse shifts to right when the tracking control is set to FIX, turn the flatblade screwdriver clockwise.

13. Perform steps 7 to 9 to check the height of the head again.
14. Fix the drum cover with the two screws (+B3 x 8).
15. Set the AGC to ON by pressing the **F8** (AGC) on the control panel.

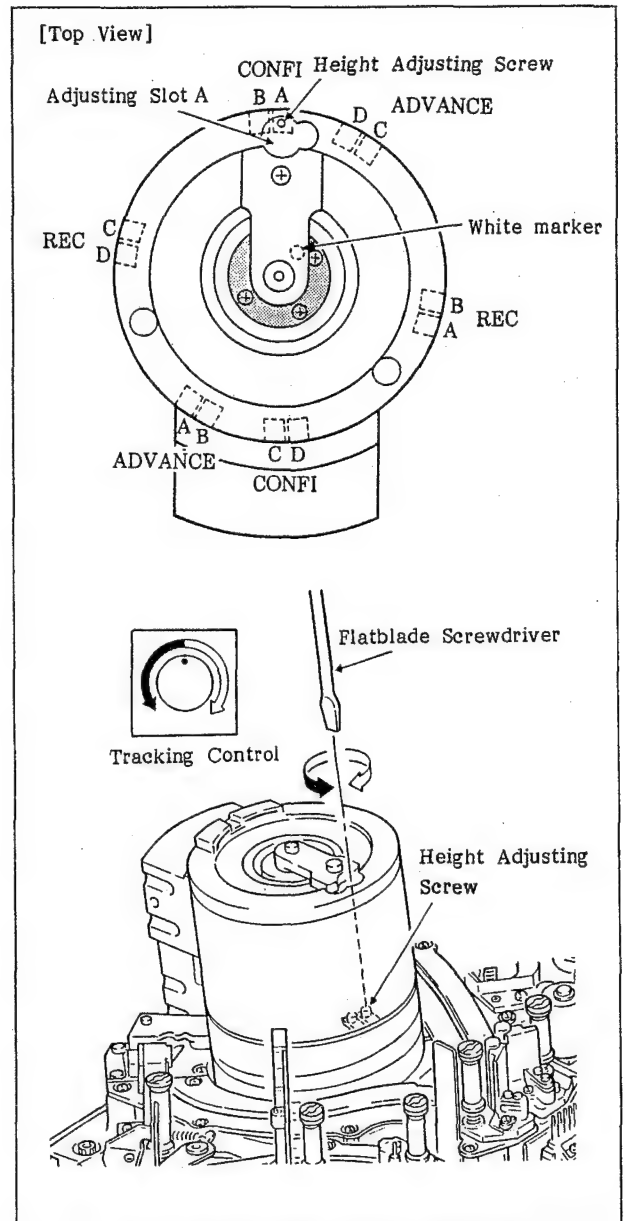

Fig. 9-22 REC Head Height Adjustment

9-13. SELF RECORD/PLAYBACK RF WAVEFORM CHECK

Background knowledge

In tracking adjustment, it is necessary that both the played-back waveform of the alignment tape and the played-back waveform of the self recorded signals meet the standard.

1. Connect CN745 (Ach) on the RF-15 board to an oscilloscope with the BNC-UM cable and connect TP6 (PG pulse) on the CD-35 board as the trigger input.
2. Load a commercially available cassette tape in the unit and record the video and audio signals.
3. Press the **TEST**, the **F2**(RF) and the **F1**(CONTINUE) keys on the control panel in sequence.
4. Check to see that "<<Test: RF VARIABLE MODE>>" is displayed. If it is displayed, set the machine in the RF VARIABLE MODE by pressing the **F1**(VAR) key.
5. Press the **F7**(PB EQUALIZE CH.A), the **F8**(AGC), the **F8**(AGC) keys on the control panel in sequence, and check to see that the AGC of CH.A is set to OFF.
6. Play the recorded portion and check that the RF waveform meets the standard.
7. If it does not, repeat the procedure from the tracking adjustment of Section 9-5.
8. Set the AGC to ON by pressing the **F8**(AGC) key on the control panel.
9. Perform the same check by connecting the oscilloscope to CN746 (Bch), to CN747 (Cch), and to CN748 (Dch).

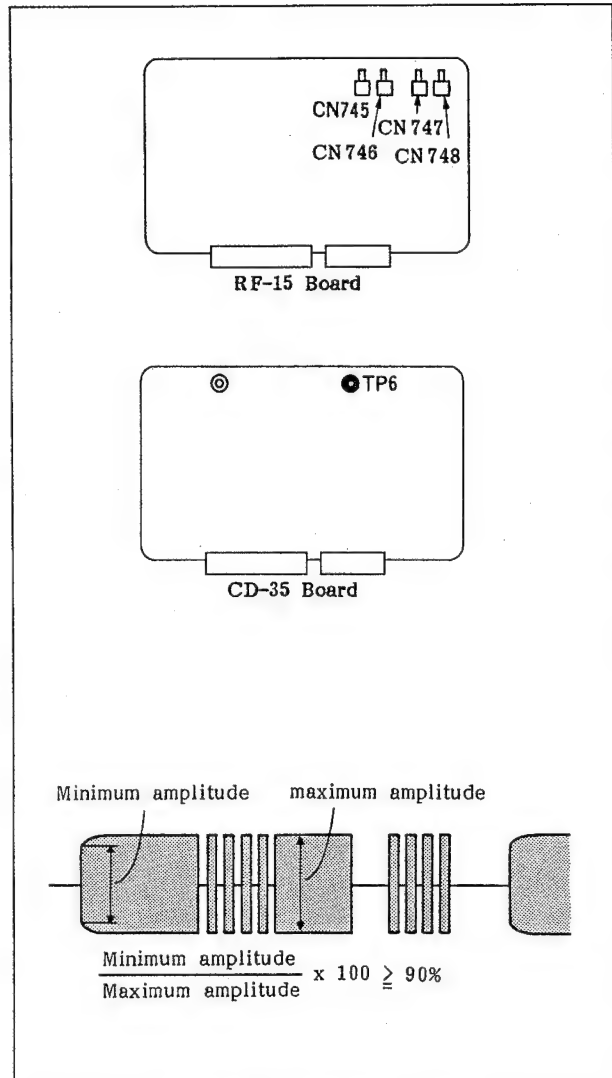
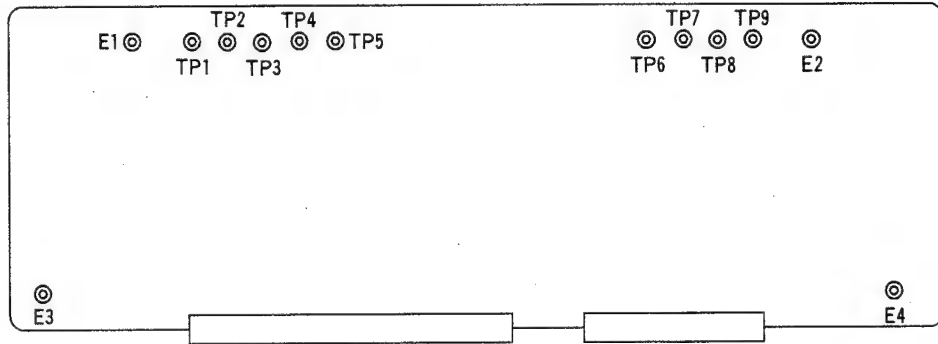

Fig. 9-23 RF Waveform Check

SECTION 10 SERVO SYSTEM ALIGNMENT

CD-35 board (component side)



RS-23 board (component side)

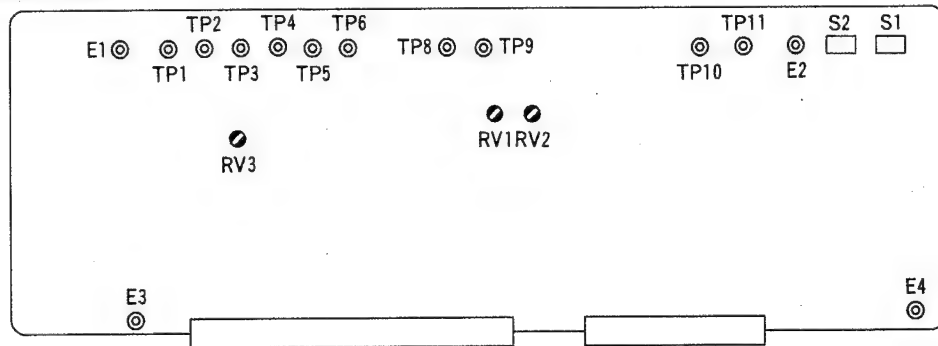

SP-01 board (component side)

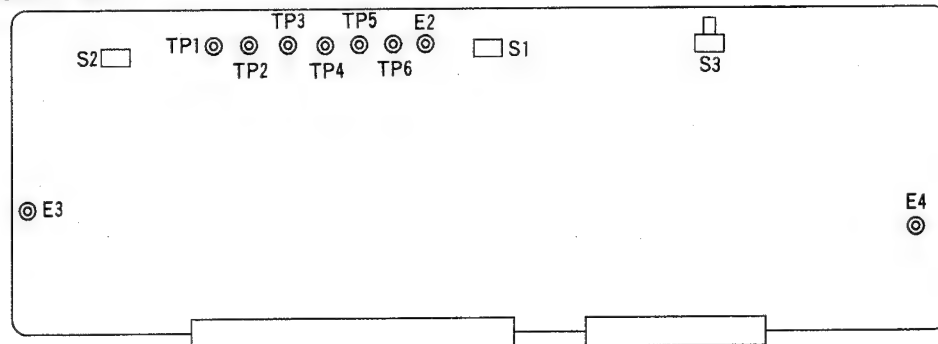

PC-36 board (component side)

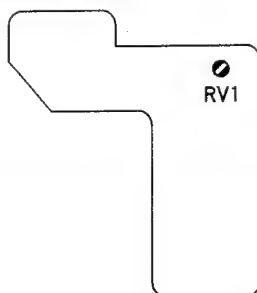

10-1. SERVO SYSTEM ALIGNMENT SEQUENCE

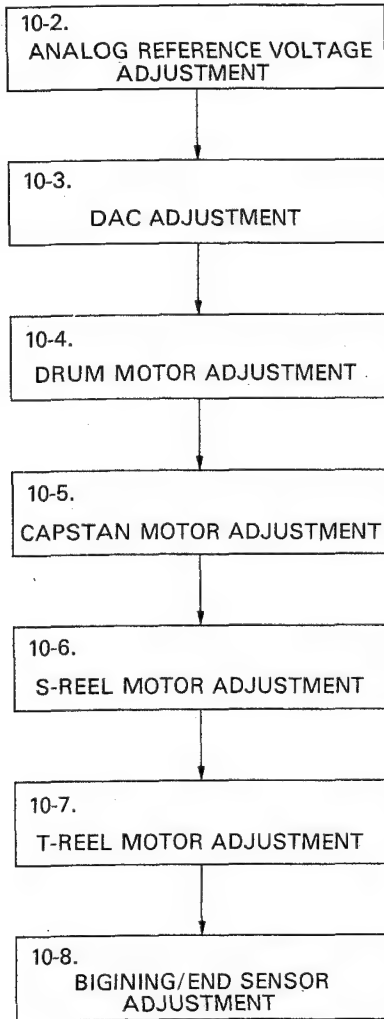

10-2. ANALOG REFERENCE VOLTAGE ADJUSTMENT

Connection; See Connection 1, Section 7-3.
Equipment; Digital voltmeter
Mode of DVR-1000;
Cassette OUT
Setting of Switches & Controls;
Same as Section 7-4

Adjustment

Pin 22C/CN720/RS-23 = $+3.30 \pm 0.01$ V
RV3/RS-23



10-3. DAC ADJUSTMENT

Connection; See Connection 1, Section 7-3.

Equipment; Oscilloscope,
Digital voltmeter

Mode of DVR-1000;
Cassette OUT

Setting of Switches & Controls;
Same as section 7-4.

Description of control panel keys

TEST ; TEST menu key

F1 to **F12** ; Function key

The symbol in parenthesis is the command assigned to each function key.

; CURSOR NEXT key

When press the CURSOR NEXT key () and CURSOR key (or) simultaneously, release the CURSOR key before the CURSOR NEXT key release.

, ; CURSOR keys

Others; 20-KEY section keys

Step 1.

Switch the power OFF, and extend the RS-23 board using the EX-129 extension board.

Step 2.

Switch the power ON, and perform the following operation from the control panel.

TEST ; TEST MENU SELECT

F3 (CHECKER); CHECKER MODE SET

F1 (CONTINUE)

F3 (C), **5**, **SET** ; TEST MODE, DAC CHECK & ADJ.

Step 3. DAC offset adjustment

Press the and keys simultaneously.

Adjustment; RS-23 board

TP6 = 0.00 ± 0.01 V

RV1

Step 4. DAC level adjustment

Press the key.

Adjustment; RS-23 board

TP6 = 3.30 ± 0.01 Vdc

RV2

Step 5. DAC linearity check

Press the key. Observe the output waveform at TP6 of the RS-23 board, and confirm that it is a stepped waveform as shown below.

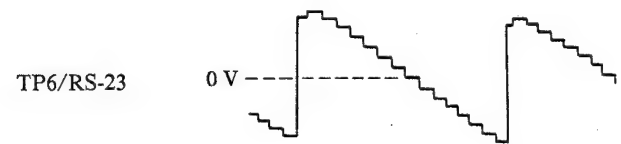

Step 6.

Switch the power OFF, and return the RS-23 board to its original position.

10-4. DRUM MOTOR ADJUSTMENT

Connection; See Connection 1, Section 7-3.
 Equipment; Oscilloscope
 Mode of DVR-1000;
 Cassette OUT
 Setting of Switches & Controls;
 Same as Section 7-4

Description of control panel keys

TEST ; TEST menu key
F1 to **F12** ; Function keys. The symbol in parenthesis is the command assigned to each function key.
 ; CURSOR NEXT key
 When press the CURSOR NEXT key () and CURSOR key (or) simultaneously, release the CURSOR key before the CURSOR NEXT key release.
, ; CURSOR keys
 Others; 20-KEY section keys

Step 1.

Switch the power OFF, and extend the CD-35 board using the EX-129 extension board.

Step 2.

Switch the power ON, and perform the following operation from the control panel.

TEST ; TEST MENU SELECT
F3 (CHECKER); CHECKER MODE SET
F1 (CONTINUE)
F3 (C), **4**, **SET** ; TEST MODE, MECHA CHECK MODE
F6 (F), **4**, **SET** ; DRUM MOTOR CHECK

Step 3. FG check

Press the key and key simultaneously and the drum will rotate. Check the output waveforms at pins 27B and 27C of edge connector CN718 of the CD-35 board.

CD-35 Board Edge Connector;

27B/CN718
 27C/CN718

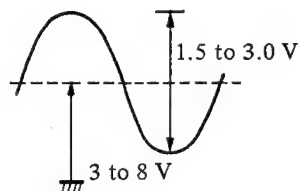

Step 4. Rotation check

Perform the following operations from the control panel, and check the display on the control panel.

When the key is pressed ... xxxx x1xxxxxB
 When the key is pressed ... xxxx x0xxxxxB

Step 5.

Perform the following operations from the control panel.

F8 (=), **0**, **SET** ; SYSTEM RESET
TEST ; TEST MENU SELECT
F3 (CHECKER); CHECKER MODE SET
F1 (CONTINUE)
F3 (C), **F1** (A), **SET** ; CAP/DRUM V-LOOP ADJ.
F3 (C), **F4** (D), **SET** ; DRUM VELOCITY CONTROL ADJ.

Step 6. PG check

Press the key and key simultaneously, and the drum will rotate. Check the output waveforms at pin 26 of edge connector CN718 of the CD-35 board.

CD-35 Board Edge Connector

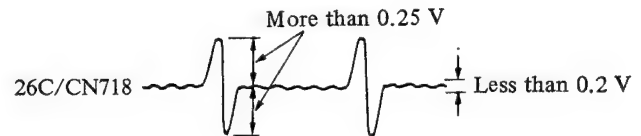

Step 7. FG-PG phase adjustment

Press the **F3** (C), **9**, and **SET** keys on the control panel and the drum will stop.

Press the **0** key and **2** key simultaneously, and the drum will rotate. Next, press the **0** key and wait for about 10 seconds. Adjustment will then start automatically.

Step 8. V-LOOP adjustment

Perform the following operations from the control panel.

SET

F3 (C), **F4** (D), **SET**; The drum will stop.

Press the **0** key and **2** key simultaneously and the drum will rotate. Next, press the **F1** (A) key and wait for about 10 seconds. Adjustment will then start automatically.

Step 9. V-LOOP check

Perform the following operations from the control panel.

SET

F3 (C), **F1** (A), **SET**; The drum will stop.

Press the **0** key and **2** key simultaneously, and the drum will rotate. Check the following items.

Check:

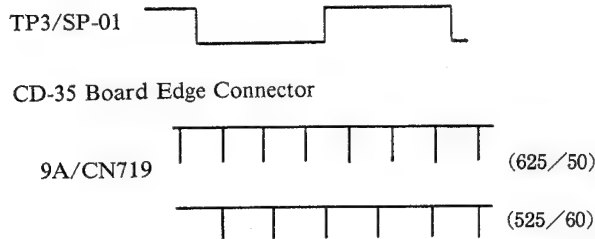

The waveforms of pin 9A/CN719/CD-35 must be static with respect to TP3/SP-01. The phases need not be in line, however.

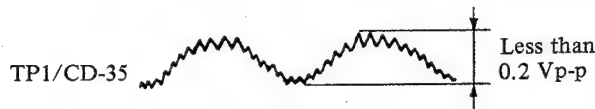

Function Control Panel

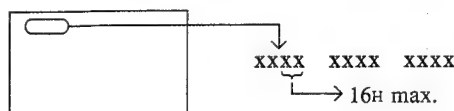

Step 10.

Perform the following operations. Check the indication on the control panel.

When the **0** key and **2** key are pressed simultaneously;

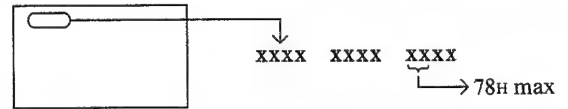

When the **0** key and **2** key are pressed simultaneously;

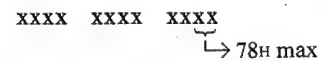

Repeat the above operations about five times, and check the display. Finally, press the **0** key and **2** key simultaneously to stop the drum.

Step 11. NOVRAM WRITE

Press the **F10** (NVW) key followed by the **SET** key. Next, press the **0** key until the message "PUSH NVWR SW" is displayed on the control panel. The NOVRAM address and data will be displayed on the control panel. If an address other than the addresses below is displayed, switch the power OFF then repeat Step 2.

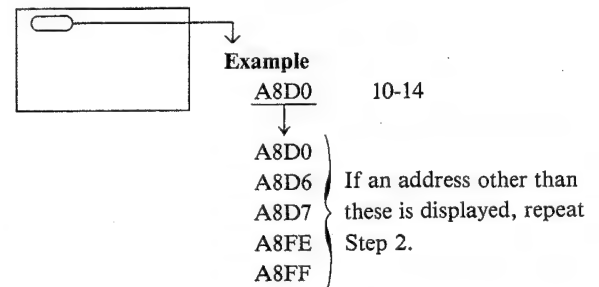

Step 12.

Press the NOVRAM WRITE switch S2/SP-01 and confirm that "READY" is displayed on the control panel.







Step 13.

Switch the power OFF, and return the CD-35 board to its original position.

10-5. CAPSTAN MOTOR ADJUSTMENT

Connection; See Connection 1, Section 7-3.
 Equipment; Oscilloscope
 Mode of DVR-1000;
 Cassette OUT
 Setting of switches & controls;
 Same as section 7-4.



Description of control panel keys

- TEST** ; TEST menu key
- F1** to **F12** ; Function keys
 The symbole in parenthesis is the command assigned to each function key.
-  ; CURSOR NEXT key
 When press the CURSOR NEXT key () and CURSOR key ( or ) simultaneously, release the CURSOR key before the CURSOR NEXT key release.
- ,  ; CURSOR keys
- Others; 20-KEY section keys

Step 1.
 Switch the power OFF, and extend the CD-35 board using the EX-129 extension board.

Step 2.
 Switch the power ON, and perform the following operation from the control panel.

- TEST** ; TEST MENU SELECT
- F3** (CHECKER); CHECKER MODE SET
- F1** (CONTINUE)
- F3** (C), **4**, **SET** ; TEST MODE, MECHA CHECK MODE
- F6** (F), **8**, **SET** ; CAPSTAN FG ADJ.

Step 3. FG Adjustments and checks
 Press the  key and  key simultaneously. The capstan motor will rotate and automatic adjustment will start. Upon completion of automatic adjustment, "READY" will be displayed on the control panel.
 Check the output waveforms at pins 29B and 29C of edge connector CN718 of the CD-35 board respectively.

CD-35 Board Edge Connector

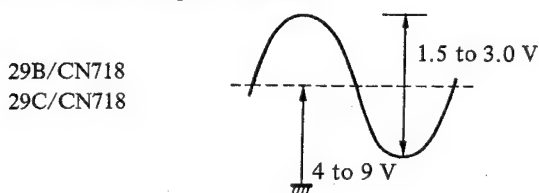



Step 4. Rotation check

Perform the following operations from the control panel.

F6 (F), **5**, **SET**

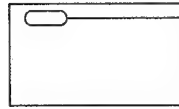
Check the display on the control panel when the following keys are pressed.



When  key is pressed ... xxxx 0xxxxxxxB

When  key is pressed ... xxxx 1xxxxxxxB

Step 5. NOVRAM WRITE

Press the **F10** (NVW) key followed by the **SET** key. Next, press the  key until the message "PUSH NVWR SW" is displayed on the control panel. The NOVRAM address and data will appear on the control panel. If an address other than the addresses below is displayed, switch the power OFF then repeat Step 2.

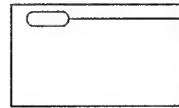

Example

A880 00-80

- A880
- A881
- A882
- A883
- A88E
- A8FF

If an address other than these is displayed, repeat the above procedure from Step 2.

Step 6.

Press the NOVRAM WRITE switch S2/SP-01 and confirm that "READY" is displayed on the control panel.

Step 7. V-LOOP adjustment

Perform the following operations from the control panel.

- F8** (=), **0** ; SYSTEM RESET
- TEST** ; TEST MENU SELECT
- F3** (CHECKER); CHECKER MODE SET
- F1** (CONTINUE)
- F3** (C), **F1** (A), **SET** ; CAPSTAN V-LOOP ADJ.
- F3** (C), **F3** (C), **SET** ; CAPSTAN VELOCITY CONTROL ADJ.
- ▷**, **F1** (A); AUTO ADJ.

Check



Step 8. NOVRAM WRITE

Press the key and key simultaneously. Press the **F10** (NVW) followed by the **SET** key. Next, press the key until the message "PUSH NVWR SW" is displayed on the control panel. The NOVRAM address and data will appear on the control panel. If an address other than the addresses below is displayed, switch the power OFF then repeat Step 2.

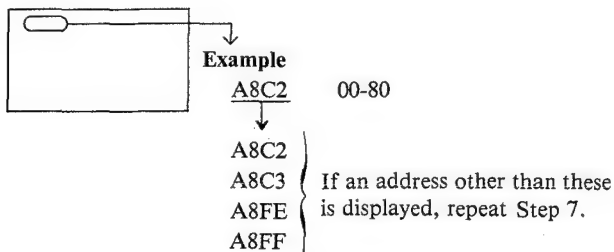

Step 9.

Press the NOVRAM WRITE switch S2/SP-01, and confirm that "READY" is displayed on the control panel.

Step 10. Capstan FG Level Adjustment

Condition: TAPE OUT

1. Perform the following operations from the control panel.

- TEST**, **CHECKER**, **CONTINUE**, **A**, **0**, **6**, and **SET**

AUTO CHECK will start. When it is completed, "OK" is indicated on the display. Then go to the next Step. If "NG" is indicated on the display, press the **A**, **0**, **6**, and **SET** keys again. Repeat this operation until "OK" is indicated on the display. Normally, "OK" will be indicated before this operation is repeated more than three times. If "NG" is still indicated even after this operation is repeated 10 times, check FG of the capstan motor.

Standard ← Display

If these two byte data increase steadily or decrease steadily, the level is getting close to "OK" state.

| | | |
|---------|----------|------------|
| Example | 8080 | 8080 |
| | ↓ | ↓ |
| | 8F8E | 8672 |
| | ↓ | ↓ |
| | 9D9E | 7983 |
| | ↓ | ↓ |
| | (Normal) | (Abnormal) |

2. Write into NOVRAM. Operation is the same as before.

NVW, **SET**,

The addresses which can be indicated on the display are as follows.

A88C, A88D, A8FE, A8FF

If addresses other than these are indicated on the display, turn the power off again and start from the beginning.

Step 11.

Switch the power OFF, and return the CD-35 board to its original position.

10-6. S-REEL MOTOR ADJUSTMENT

Connection; See Connection 1, Section 7-3.

Equipment; Oscilloscope

Mode of DVR-1000;

Cassette OUT

Setting of switches & controls;

See Section 7-4.

Description of control panel keys

TEST ; TEST menu keys

F1 to **F12** ; Function keys

The symbol in parenthesis is the command assigned to each function key.

□ ; CURSOR NEXT key

When press the CURSOR NEXT key (**□**) and CURSOR key (**◀** or **▶**) simultaneously, release the CURSOR key before the CURSOR NEXT key release.

◀, **▶** ; CURSOR keys

Others; 20-KEY section keys

Step 1.

Switch the power OFF, and extend the RS-23 board using the EX-129 extension board.

Step 2.

Switch the power ON, and perform the following operation from the control panel.

TEST ; TEST MENU SELECT

F3 (CHECKER); CHECKER MODE SET

F1 (CONTINUE)

F3 (C), **4**, **SET** ; TEST MODE, MECHA CHECK MODE

F6 (F), **9**, **SET** ; S-REEL FG ADJ.

Step 3. FG Adjustments and Checks

Press the **□** and **▶** keys simultaneously. The reel motor will rotate, and automatic adjustment will start.

Upon completion of adjustment, "READY" will be displayed on the function control panel. Measure the output voltage waveforms at pins 29B and 29C of the CN720 edge connector of the RS-23 board respectively.

RS-23 Board Edge Connector

29B/CN720
29C/CN720

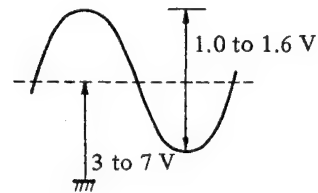

Step 4. Rotation check

Perform the following operations from the control panel.

F6 (F), **6**, **SET**

Press the **◀** key and confirm that the S-REEL motor rotates counterclockwise. Press the **▶** key and confirm that the motor rotates clockwise.

Step 5. Torque adjustment

Perform the following operation from the control panel.

F3 (C), **0**, **SET**

T, **0**, **SET**

Check the data displayed on the control panel.

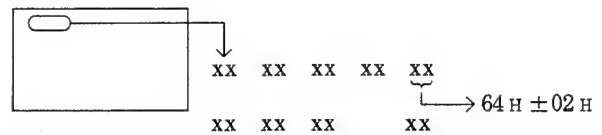

If the displayed data is not within $64H \pm 02H$, repeat the following operation until the correct data is displayed.

T, **1**, **SET**

Step 6. NOVRAM WRITE

Press the **F10** (NVW) followed by the **SET** key. Next, press the **/** key until the message "PUSH NVWR SW" is displayed on the control panel. The NOVRAM address and data will appear on the control panel. If an address other than the addresses below is displayed, switch the power OFF then repeat Step 2.

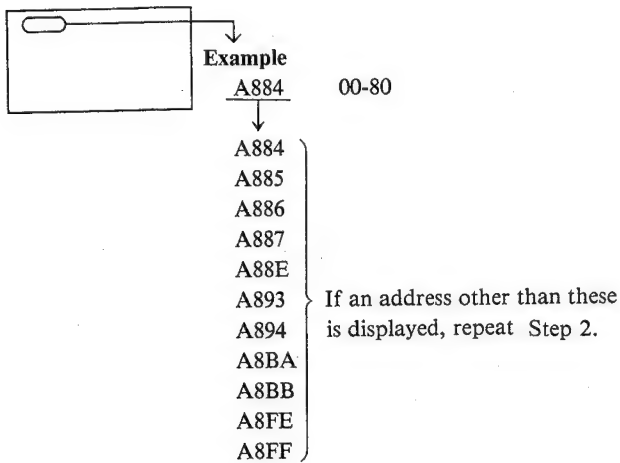

Step 7.

Press the NOVRAM WRITE switch S2/SP-01, and confirm that "READY" is displayed on the control panel.

Step 8.

Switch the power OFF, and return the RS-23 board to its original position.

10-7. T-REEL MOTOR ADJUSTMENT

Connection; See Connection 1, Section 7-3.
 Equipment; Oscilloscope
 Mode of DVR-1000;
 Cassette OUT
 Setting of switches & controls;
 See Section 7-4.

Description of control panel keys

TEST; TEST menu key
F1 to **F12**; Function keys
 The symbol in parenthesis is the command assigned to each function key.
□; CURSOR NEXT key
 When press the CURSOR NEXT key (**□**) and CURSOR key (**◀** or **▶**) simultaneously, release the CURSOR key before the CURSOR NEXT key release.
◀, **▶**; CURSOR keys
 Others; 20-KEY section keys

Step 1.

Switch the power OFF, and extend the RS-23 board using the EX-129 extension board.

Step 2.

Switch the power ON, and perform the following operation from the control panel.

TEST; TEST MENU SELECT
F3 (CHECKER); CHECKER MODE SET
F1 (CONTINUE)
F3 (C), **4**, **SET**; TEST MODE, MECHA CHECK MODE
F6 (F), **F1** (A), **SET**; T-REEL FG ADJ.

(10-7. T-REEL MOTOR ADJUSTMENT)

Step 3. FG check

Press the and keys simultaneously. The reel motor will rotate, and automatic adjustment will start. Upon completion of adjustment, "READY" will be displayed on the function control panel. Measure the output voltage waveforms at pins 28B and 28C of the CN720 edge connector of the RS-23 board respectively.

RS-23 Board Edge Connector

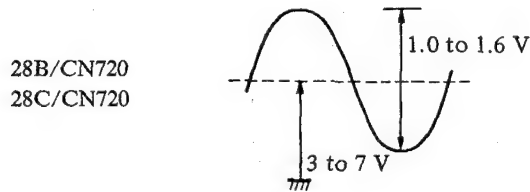

Step 4. Rotation check

Perform the following operations from the control panel.

(F), ,

Press the key and confirm that the T-REEL motor rotates counterclockwise. Press the key and confirm that the motor rotates clockwise.

Step 5. Torque adjustment

Perform the following operations from the control panel.

(C), ,

, ,

Check the data displayed on the control panel.

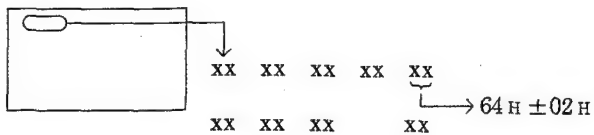

If the displayed data is not within $64H \pm 02H$, repeat the following operation until the correct data is displayed.

, ,

Step 6. NOVRAM WRITE

Press the (NVW) followed by the key. Next, press the key until the message "PUSH NVWR SW" is displayed on the control panel. The NOVRAM address and data will appear on the control panel. If an address other than the addresses below is displayed, switch the power OFF then repeat Step 2.

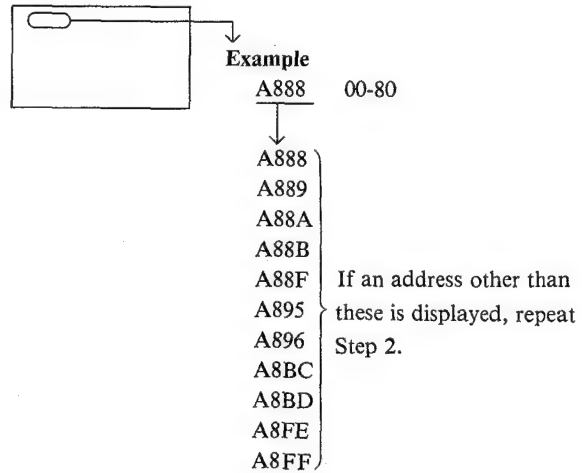

Step 7.

Press the NOVRAM WRITE switch S2/SP-01, and confirm that "READY" is displayed on the control panel.

Step 8.

Switch the power OFF, and return the RS-23 board to its original position.

10-8. TAPE BEGINNING/END SENSOR ADJUSTMENT

Connection; See Connection 1, Section 7-3

Mode of DVR-1000;

Cassette OUT

Setting of switches & controls;

Same as Section 7-4.

Description of control panel keys

TEST; TEST menu key

F1 to **F12**; Function keys

The symbol in parenthesis is the command assigned to each function key.

□; CURSOR NEXT key

When press the CURSOR NEXT key (**□**) and CURSOR key (**◀** or **▶**) simultaneously, release the CURSOR key before the CURSOR NEXT key release.

◀, **▶**; CURSOR keys

Others; 20-KEY section keys

Step 1.

Perform the following operations from the control panel.

TEST; TEST MENU SELECT

F3 (CHECKER); CHECKER MODE SET

F1 (CONTINUE)

F5 (E), **F1** (A), **SET**; BEGINNING/END SENSOR DATA READ

Step 2. Adjustment

Perform the following adjustment while observing the data displayed on the control panel.

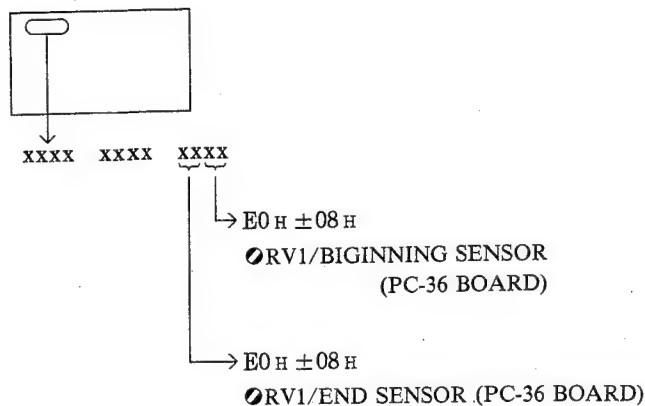

Step 3.

Press **F12** (EXIT).



SECTION 11 ANALOG SIGNAL SYSTEM ALIGNMENT

AE-05 board (component side)

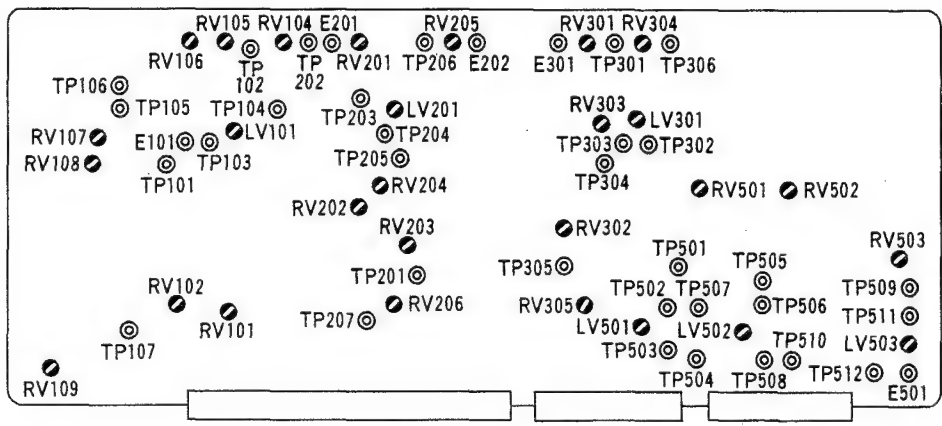

LO-05 board (component side)

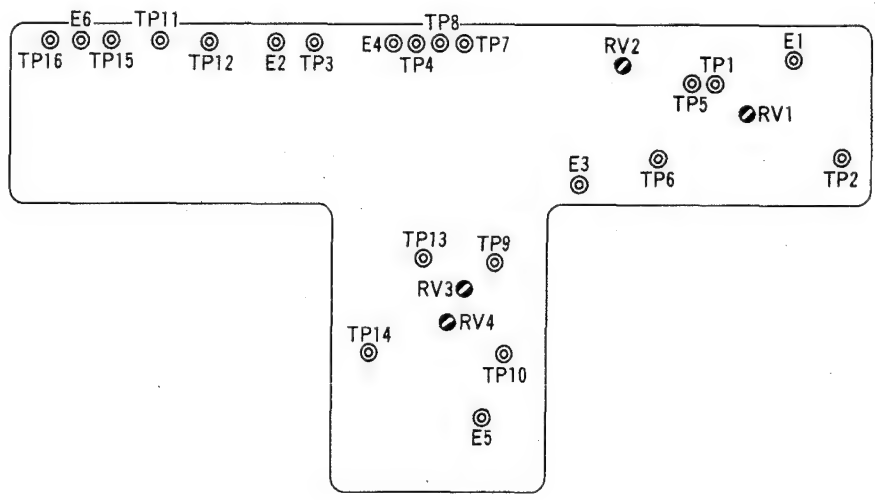

11-1. ANALOG SIGNAL SYSTEM ALIGNMENT PROCEDURE

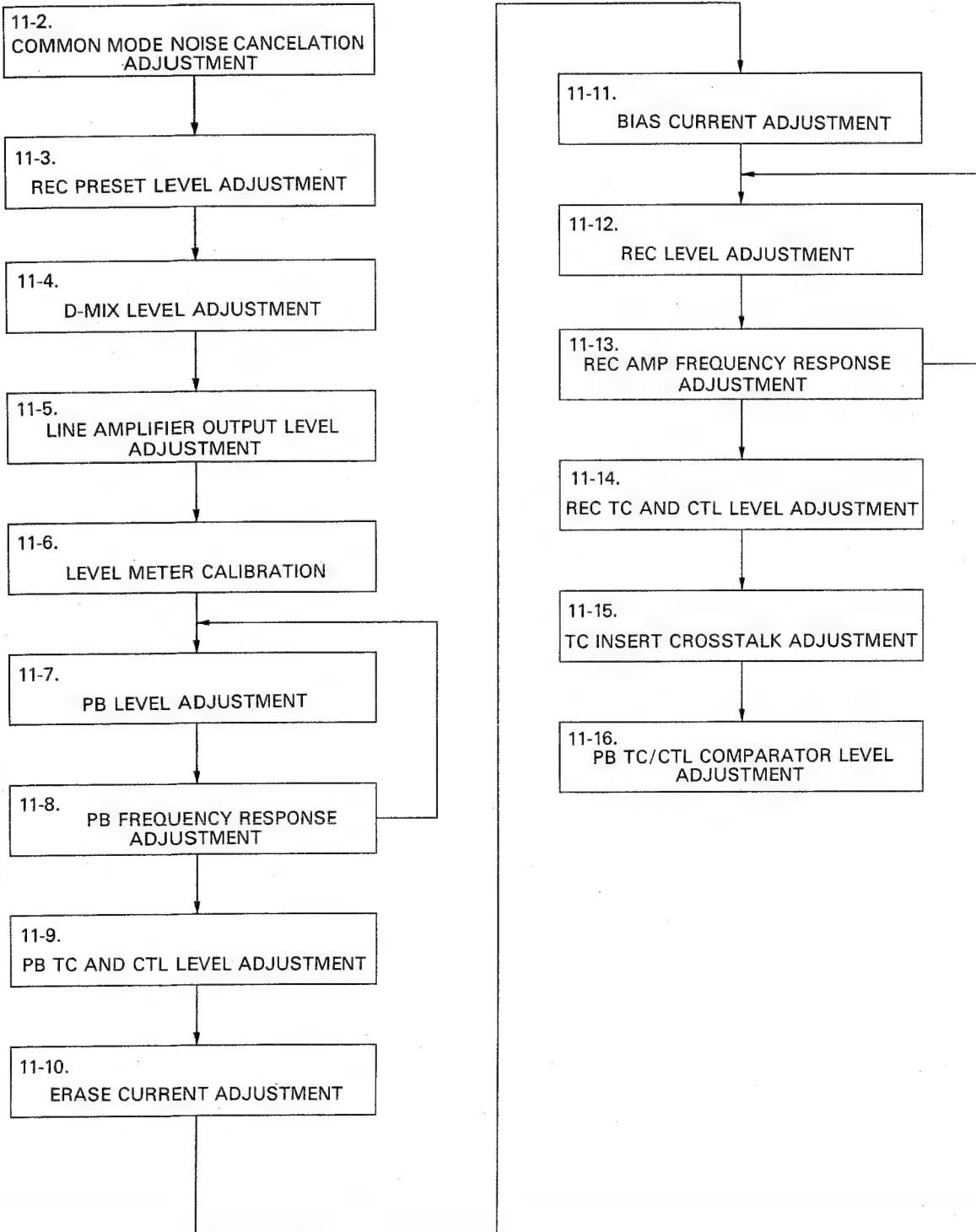

11. ANALOG SIGNAL SYSTEM ALIGNMENT



11-2. COMMON MODE NOISE CANCELATION ADJUSTMENT

Connection; See Connection 1, Section 7-3.
Equipment; Audio distortion meter
Mode of DVR-1000;
STOP
Setting of Switches & Controls;
CUE INPUT IMPEDANCE SW/CN PNL.;
600 ohm
CUE INPUT SOURCE sel/SETUP MENU/
FUNCTION CONT. PNL.; LINE
For other settings same as section 7-4.
Input signal (CUE IN);
1 kHz/ +8 dBm (unbalance input)

Step 1.

Extend the AE-05 board using the EX-129 extension board.

Step 2.

Short circuit pins 12c and 12b of CN713 on the extension board.

Step 3.

Input 1 kHz/ +8 dBm unbalance signal to CUE IN connector.

Step 4. Common mode noise cancelation adjustment

TP101-E101/AE-05 = less than -75 dBm
RV102/AE-05

Step 5.

Remove the jumper and return the AE-05 board to its original position.

11-3. REC PRESET LEVEL ADJUSTMENT

Connection; See Connection 1, Section 7-3.
Equipment; Audio distortion meter
Mode of DVR-1000;
STOP
Setting of Switches & Controls;
CUE INPUT IMPEDANCE SW/CN PNL.;
600 ohm
CUE INPUT SOURCE sel/SETUP MENU/
FUNCTION CONT. PNL.; LINE
For other settings same as section 7-4.
Input signal (CUE IN); 1 kHz/ +8 dBm

Step 1.

Input 1 kHz/ +8 dBm to CUE IN connector.

Step 2. REC preset level adjustment

TP101-E101/AE-05 = -26.0 ± 0.1 dBm
RV103/AE-05

11-4. D-MIX LEVEL ADJUSTMENT

Connection; See Connection 1, Section 7-3.
Equipment; Audio distortion meter
Mode of DVR-1000;
STOP
Setting of Switches & Controls;
CUE INPUT IMPEDANCE SW/CN PNL.;
600 ohm
CUE INPUT SOURCE sel/SETUP MENU/
FUNCTION CONT. PNL.; D-MIX
For other settings same as section 7-4.
Input signal (CUE IN);
1 kHz/ +8 dBm

Adjustment

TP101-E101/AE-05 = -26.0 ± 0.1 dBm
RV101/AE-05

11-5. LINE AMPLIFIER OUTPUT LEVEL ADJUSTMENT

Connection; See Connection 1, Section 7-3.
 Equipment; Audio distortion meter
 Mode of DVR-1000;
 STOP
 Setting of Switches & Controls;
 CUE INPUT IMPEDANCE SW/CN PNL.;
 600 ohm
 CUE INPUT SOURCE sel/SET UP MENU/
 FUNCTION CONT. PNL.; LINE
 TC REG INT/EXT select/TC & CHAR
 MENU/FUNCTION CONT. PNL.; INT
 For other settings same as Section 7-4.

Input signal (CUE IN); 1 kHz/+8 dBm

Adjustment

CUE OUT connector = $+8.0 \pm 0.1$ dBm
 ⓄRV1/LO-05
 MONITOR OUT L connector = $+8.0 \pm 0.1$ dBm
 ⓄRV4/LO-05
 MONITOR OUT R connector = $+8.0 \pm 0.1$ dBm
 ⓄRV3/LO-05
 TIME CODE OUT connector = 1.20 ± 0.01 Vrms
 (600-ohm load)
 ⓄRV2/LO-05

11-6. LEVEL METER CALIBRATION

Connection; See Connection 1, Section 7-3.
 Mode of DVR-1000;
 STOP
 Setting of switches & controls;
 CUE INPUT IMPEDANCE SW/CN PNL.;
 600 ohm
 CUE INPUT SOURCE sel/SET UP MENU/
 FUNCTION CONT. PNL.; LINE
 For other setting same as section 7-4.

Input signal (CUE IN);
 1 kHz/+8 dBm

Adjustment

CUE level meter = 0.0 ± 0.5 dBm
 ⓄRV109/AE-05

11-7. PB LEVEL ADJUSTMENT

Connection; See Connection 1, Section 7-3.
 Equipment; Audio distortion meter
 Mode of DVR-1000;
 PLAY (alignment tape playback)
 Setting of Switches & Controls;
 Same as section 7-4.

Adjustment

Play back 1 kHz/0 VU part of alignment tape.
 CUE OUT connector = $+8.0 \pm 0.1$ dBm
 ⓄRV108/AE-05

11-8. PB FREQUENCY RESPONSE ADJUSTMENT

Connection; See Connection 1, Section 7-3.
 Equipment; Audio distortion meter
 Mode of DVR-1000;
 PLAY (alignment tape playback)
 Setting of Switches & Controls;
 Same as section 7-4.

Step 1.

Play back 7 kHz/-10 VU part of alignment tape and confirm as follow.

CUE OUT connector = -2.0 ± 0.1 dBm

If not, perform the following procedures.

1. Press the **LEVEL ADJ** key.
2. Press the **F6** (CUE) key. Confirm that the function display for the **F6** key is inverted.
3. Press the **UNITY/VAR** button to change the function display for the **F6** key to VAR.
4. Turn the ADJUSTMENT control of the control panel and adjust as follows;

CUE OUT connector = -2.0 ± 0.1 dBm
 ⓄADJUSTMENT control/
 FUNCTION CONT. PNL.

Step 2.

Play back 10 kHz/-10 VU part of alignment tape.
 CUE OUT connector = $-2.0^{+1.5}_{-3.0}$ dBm
 ⓄRV107/AE-05

Step 3.

After adjustment, perform PB Level Adjustment of Section 11-7.

11-9. PB TC AND CTL LEVEL ADJUSTMENT

Connection; See Connection 1, Section 7-3.
 Equipment; Oscilloscope
 Mode of DVR-1000; PB (alignment tape playback)
 Setting of Switches & Controls; Same as section 7-4.

Step 1.

Play back alignment tape and perform the following adjustments.

Step 2. PB TC level adjustment

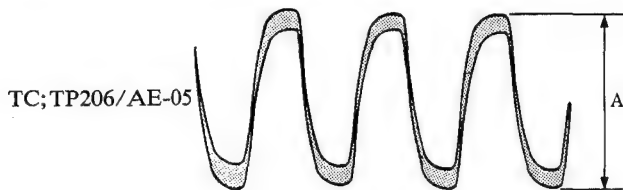

$A = 5.0 \pm 0.3 \text{ Vpp}$
 ⓄRV205/AE-05

Step 3. PB CTL level adjustment

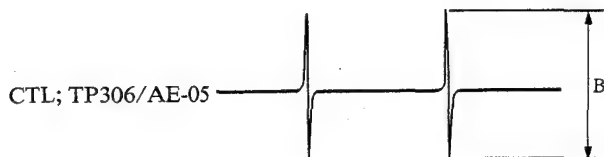

$B = 4.0 \pm 0.3 \text{ Vpp}$
 ⓄRV304/AE-05

11-10. ERASE CURRENT ADJUSTMENT

Connection; See Connection 1, Section 7-3.
 Equipment; Oscilloscope
 Mode of DVR-1000; INSERT (CUE, TC), REC (CTL)
 Setting of Switches & Controls; Same as section 7-4.

Step 1.

Put unit into INSERT (CUE, TC) and REC (CTL) modes.

Step 2. Erase current resonance adjustment

CUE; TP503-E501/AE-05 = level max
 ⓄLV501/AE-05
 TC; TP507-E501/AE-05 = level max
 ⓄLV502/AE-05
 CTL; TP511-E501/AE-05 = level max
 ⓄLV503/AE-05

Step 3. Erase current level adjustment

CUE; TP504-E501/AE-05 = $160 \pm 10 \text{ mVpp}$
 ⓄRV501/AE-05
 TC; TP508-E501/AE-05 = $160 \pm 10 \text{ mVpp}$
 ⓄRV502/AE-05
 CTL; TP512-E501/AE-05 = $310 \pm 10 \text{ mVpp}$
 ⓄRV503/AE-05

11-11. BIAS CURRENT ADJUSTMENT

Connection; See Connection 1, Section 7-3.
 Equipment; Oscilloscope
 Mode of DVR-1000;

REC → PB

Setting of Switches & Controls;
 TC REG INT/EXT sel/TC & CHAR
 MENU/ FUNCTION CONT. PNL.; INT
 CUE INPUT IMPEDANCE SW/CN PNL.;
 600 ohm
 CUE INPUT SOURCE sel/SETUP MENU/
 FUNCTION CONT. PNL.; LINE
 For other settings same as section 7-4.

Input signal (CUE IN); NO SIGNAL ⇒ 1 kHz/+8 dBm

Step 1.

Put unit in REC mode.

Step 2. Bias current resonance adjustment

CUE; TP104-E101/AE-05 = Level max
 ⓪LV101/AE-05

TC; TP204-E201/AE-05 = Level max
 ⓪LV201/AE-05

Step 3.

Input 1 kHz/+8 dBm to CUE IN connector.

Step 4. Adjustment

Turn CUE (TC) BIAS LEVEL ADJ controls RV106/AE-05 (RV202/AE-05) fully counterclockwise. Put unit in REC mode, and slowly turn CUE (TC) BIAS LEVEL controls clockwise. Play back recorded part and search for peak. Repeat self recording and playback while adjusting RV106 until CUE PB level is 0.5 dB below peak. Similarly, adjust RV202 so that TC PB level is peak.

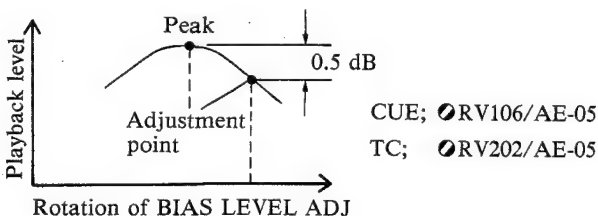

11-12. REC LEVEL ADJUSTMENT

Connection; See Connection 1, Section 7-3.
 Equipment; Audio distortion meter, Oscilloscope
 Mode of DVR-1000;

See each step.

Setting of Switches & Controls;
 CUE INPUT IMPEDANCE SW/CN PNL.;
 600 ohm
 CUE INPUT SOURCE sel/SETUP MENU/
 FUNCTION CONT. PNL.; LINE
 For other settings same as section 7-4.

Input signal (CUE IN);
 1 kHz/+8 dBm

Step 1.

Put unit in STOP mode and check CUE OUT level.

Spec.; CUE OUT connector = +8.0 ± 0.1 dBm

If level does not meet specifications, perform Line Amplifier Output Level Adjustment of Section 11-5.

Step 2.

Play back 1 kHz/0 VU part of alignment tape. Check CUE OUT level.

Spec.; CUE OUT connector = +8.0 ± 0.1 dBm

If level does not meet specification, perform PB Level Adjustment of Section 11-7.

Step 3.

Input 1 kHz/+8 dBm signal to CUE IN connector. Using general tape, perform self recording and playback. Check CUE OUT level.

Spec.; CUE OUT connector = +8.0 ± 0.1 dBm
 ⓪RV104/AE-05

If level does not meet specification, turn RV104 slightly and repeat the confirmation.

11-13. REC AMP FREQUENCY RESPONSE ADJUSTMENT

Connection; See connection 1, Section 7-3.
 Equipment; Audio distortion meter
 Mode of DVR-1000;
 See each step.
 Setting of Switches & Controls;
 CUE INPUT IMPEDANCE SW/CN PNL.;
 600 ohm
 CUE INPUT SOURCE sel/SETUP MENU/
 FUNCTION CONT. PNL.; LINE
 For other settings same as section 7-4.
 Input signal (CUE IN); 1 kHz/+8 dBm → 1 kHz/-2 dBm →
 10 kHz/-2 dBm

Step 1.
 Perform Steps 1 and 2 of Section 11-12 Record Level Adjustment.

Step 2.
 Using general purpose tape, record 1 kHz/-2 dBm and 10 kHz/-2 dBm signals. Play back the recorded parts and check 10 kHz signal level with respect to 1 kHz signal (reference).

Spec.; CUE OUT connector
 Level of 10 kHz = level of 1 kHz ± 0.5 dB
 ○RV105/AE-05

If level does not meet specification, turn RV105 slightly and repeat step 2.

Step 3.
 After adjustment, perform Steps 3 and 4 of 11-12 REC Level Adjustment.

11-14. REC TC AND CTL LEVEL ADJUSTMENT

Connection; See Connection 1, Section 7-3.
 Equipment; Oscilloscope
 Mode of DVR-1000;
 REC → PB
 Setting of Switches & Controls;
 TC REG INT/EXT sel/TC & CHAR
 MENU/ FUNCTION CONT PNL.; INT
 For other settings see Section 7-4.

Step 1. REC TC level adjustment
 Using general purpose tape, perform self recording and playback. Play back recorded part and check as follows.

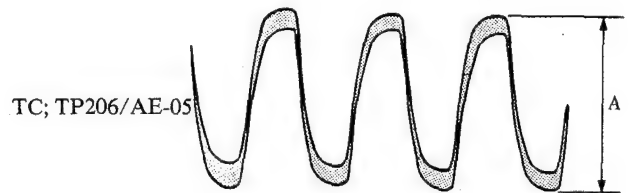

$$A = 5.0 \pm 0.3 \text{ Vpp}$$

○RV201/AE-05

If the level does not meet specifications, place unit in record mode and turn RV201 slightly while recording. Play back the recorded part and repeat the confirmation.

Step 2. REC CTL level adjustment.
 Using general purpose tape, perform self recording and playback.
 Playback recorded part and check as follows.



$$B = 4.0 \pm 0.3 \text{ Vpp}$$

○RV301/AE-05

If the level does not meet specifications, place unit in record mode and turn RV301 slightly while recording. Play back the recorded part and repeat the confirmation.

11-15. TC INSERT CROSSTALK ADJUSTMENT

Connection; See Connection 1, Section 7-3
 Equipment; Oscilloscope
 Mode of DVR-1000;
 REC TC INSERT
 Setting of switches & controls;
 TC REG INT/EXT/sel/TC & CHAR
 MENU/FUNCTION CONT. PNL.; INT
 For other settings same as section 7-4.

Step 1.
 Using general purpose tape, perform recording for 2 minutes.

Step 2. Adjustment
 While playing back the recorded part, put unit into TC INSERT mode, and perform adjustment so that crosstalk becomes minimum.

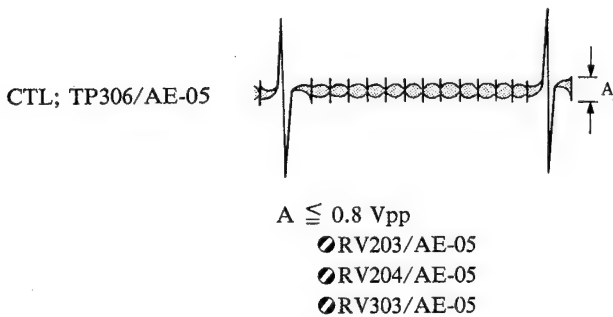

11-16. PB TC.CTL COMPARATOR LEVEL ADJUSTMENT

Connection; See Connection 1, Section 7-3.
 Equipment; Oscilloscope
 Mode of DVR-1000;
 REC → PLAY
 Setting of Switches & Controls;
 Same as section 7-4

Step 1.
 Using general purpose tape, perform recording for 2 minutes. Play back recorded part and perform the following adjustments.

Step 2. PB TC comparator level adjustment

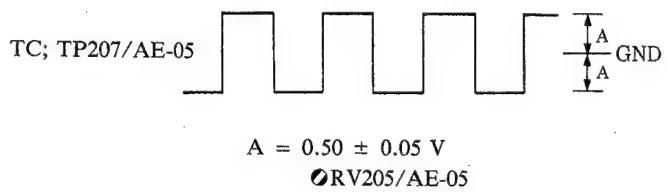

Step 3. PB CTL comparator level adjustment

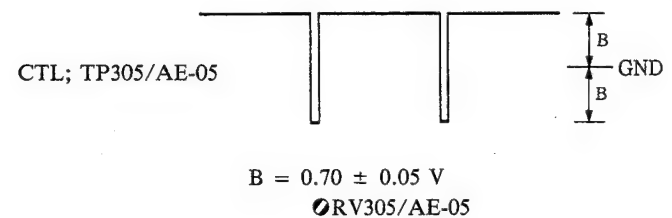

SECTION 12 RF SIGNAL SYSTEM ALIGNMENT

RF-15 board (component side)

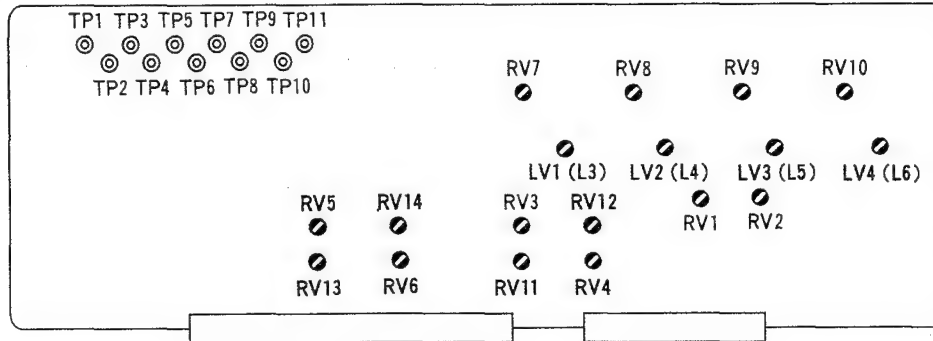

SP-01 board (component side)

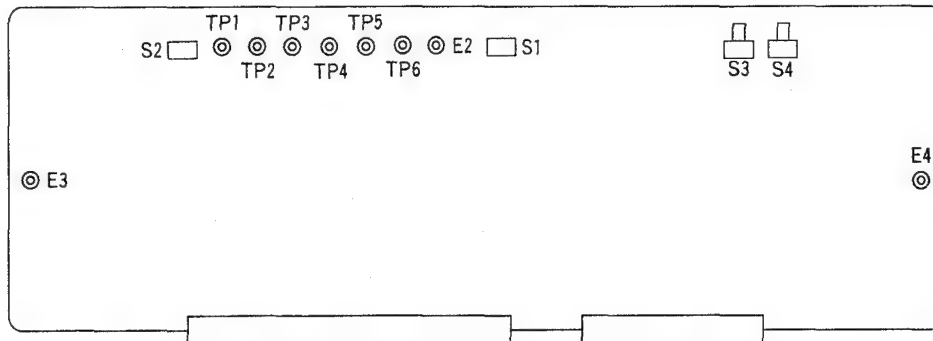

12-1. ALIGNMENT SEQUENCE

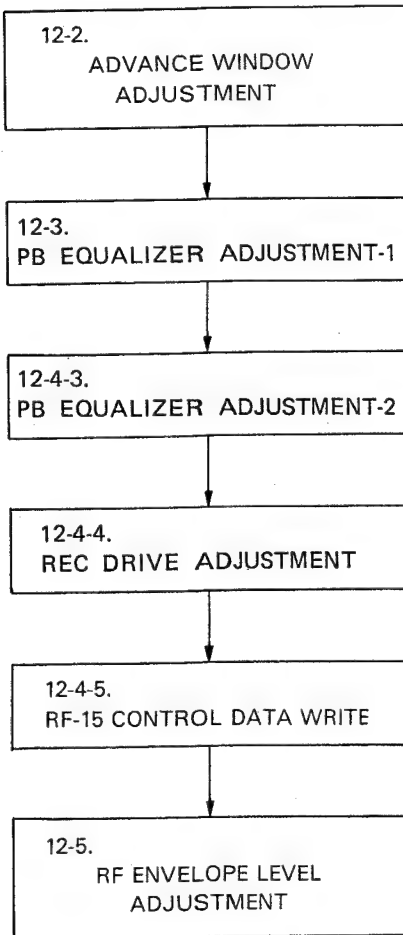

12-2. ADVANCE WINDOW ADJUSTMENT

Equipment; Oscilloscope
 Mode of DVR-1000; REC → PLAY
 Setting of Switches & Controls;
 Same as Section 7-4.
 Input signal (VIDEO INPUT/DVPC-1000);
 Free

Adjustment RF-15 board

Step 1.

Adjust ADVANCE WINDOW in REC mode.

For A & B Channels

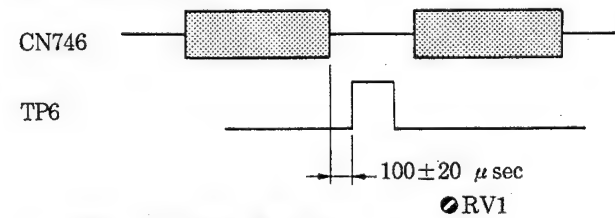

TRIG; JP3/TG-28/DVPC-1000

For C & D Channels

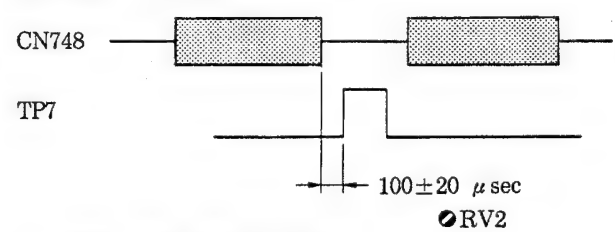

TRIG; JP3/TG-28/DVPC-1000

Step 2.

Play back the portion which was recorded in Step 1 and verify that the audio data played back with the ADVANCE head of channels A and B (channels C and D) is contained between two high pulses of TP6 (TP7).

For A & B Channels

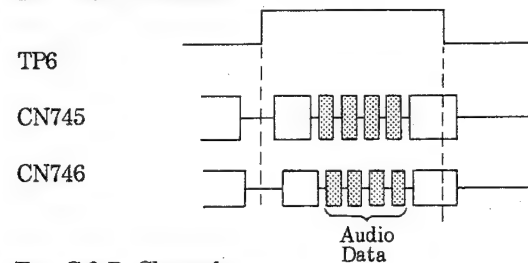

For C & D Channels

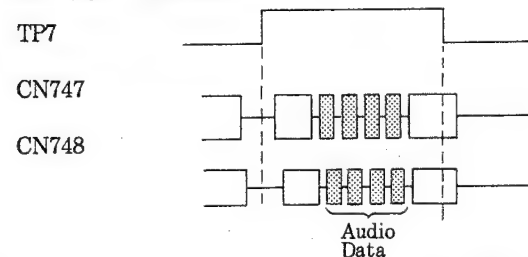

12-3. PB EQUALIZER ADJUSTMENT

Connection; See Connection 2, Section 7-3.
 Equipment; Oscilloscope
 Mode of DVR-1000;
 PLAY (alignment tape playback)
 •DR5-1A (525/60)
 •DR5-1B (625/50)
 TC 00^H : 10^M : 00^S :
 ?
 00 : 15 : 00
 Setting of Switches & Controls;
 Same as Section 7-4.
 Input signal (VIDEO INPUT/DVPC-1000);
 Free

Step 1. RAW ERROR MODE Setting of DVPC-1000
 Set the S3 on the IF board to ON (TEST MODE), and the DIP switch SW101-1 on the CI board to ON (INNER ERROR RAW MODE).

Step 2. Expansion of the DVR-1000 Tracking Range
 Perform the following operations from the control panel, expand the tracking.
 [TEST], [F3] (CHECKER), [F1] (CONTINUE), [F3] (C), [F6] (F), and [SET]
 Then, [F12] (EXIT)

Step 3. EQUALIZEW OFFSET adjustment
 While observing the waveforms at TP1, TP2, TP3, and TP4 on the CI-01 board, adjust RV7, RV8, RV9, and RV10 on the RF-15 board so that the INNER ERROR RATE becomes minimum.
 Adjust the tracking after each adjustment is made.

INNER ERROR FLAG MONITOR
 /CI-01/DVPC-1000

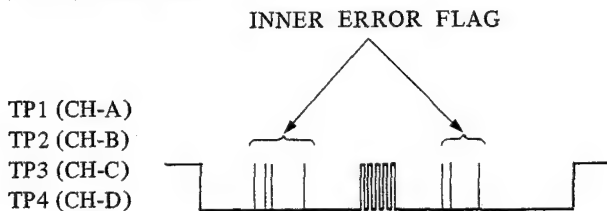

TRIG; TP3/TG-28/DVPC-1000

Spec.; INNER ERROR FLAG = Minimum
 CH-A; ⓪RV7/RF-15
 CH-B; ⓪RV8/RF-15
 CH-C; ⓪RV9/RF-15
 CH-D; ⓪RV10/RF-15

Step 4. LPF EQUALIZER Adjustment
 The following adjustment of the RF-15 boards with a board number suffix of -11 or -12 can be made by L3, L4, L5, or L6.
 While observing the waveforms at TP1, TP2, TP3, and TP4 on the CI-01 board, adjust ⓪LV1 (L3), ⓪LV2 (L4), ⓪LV3 (L5), and ⓪LV4 (L6) on the RF-15 board so that the INNER ERROR RATE becomes minimum.
 Adjust the tracking after each adjustment is made.

INNER ERROR FLAG MONITOR
 /CI-01/DVPC-1000

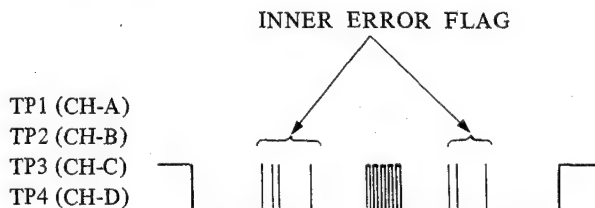

TRIG; TP3/TG-28/DVPC-1000

Spec.; INNER ERROR FLAG = Minimum
 CH-A; ⓪LV1 (L3)/RF-15
 CH-B; ⓪LV2 (L4)/RF-15
 CH-C; ⓪LV3 (L5)/RF-15
 CH-D; ⓪LV4 (L6)/RF-15

Step 5. Setting of DVPC-1000
 Turn S3 on the IF-139 board and also SW101-1 on the CI-01 board OFF.
 Turn SW101-1 on the CI board and also S3 on the IF board OFF. (TEST MODE Reset)

12-4. SETTING RF-15 CONTROL DATA

Connection; See Connection 2, Section 7-3.

Equipment; Oscilloscope

DVR-1000 mode;

See each section.

Setting of Switches & Controls;

Same as Section 7-4.

Input signal (VIDEO INPUT/DVPC-1000);

Free

Description of control panel keys

TEST; TEST menu key

F1 to **F12**; Function keys.

The symbol in parenthesis is the command assigned to each function key.

Other keys; 20-KEY Section keys



12-4-1. RF-15 Control Data Change Procedure

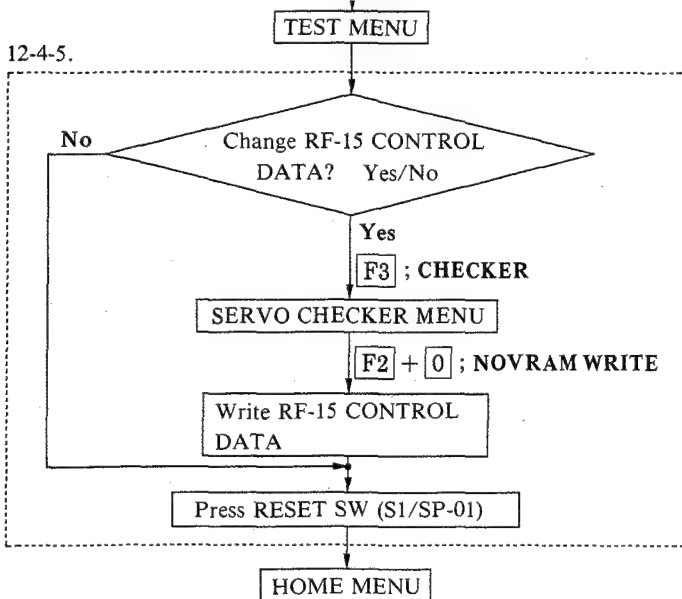
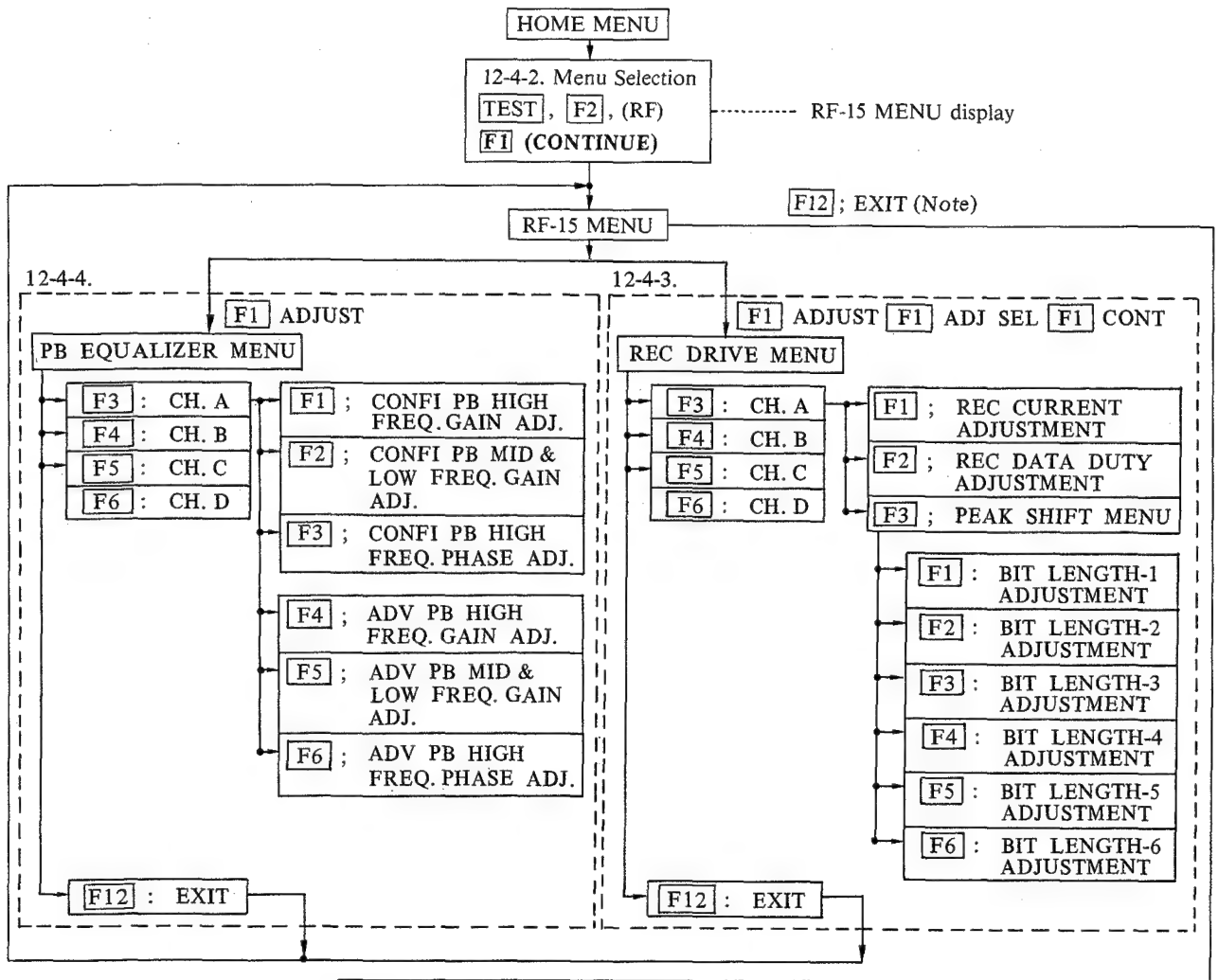

Note:

When RF-15 CONTROL DATA is changed, press the **F12** (EXIT) key in the VARIABLE mode. If the RF menu is terminated in the PRESET mode, the updated control data will be lost. (See section 12-4-2 for details.)

12-4-2. Menu Selection

Perform the following operations from the control panel.

[TEST]; TEST MENU SELECT

[F2] (RF); RF MENU SELECT

[F1] (CONTINUE)

The control panel display will change as shown below. When data such as shown in Example 1 is displayed on the screen, go to the next step. When data such as shown in Example 2 is displayed on the screen, press the **[F1]** (VAR) key to set to the VARIABLE mode, then go to the next step. Read the following note carefully before making adjustment.

<Example 1. VARIABLE MODE>

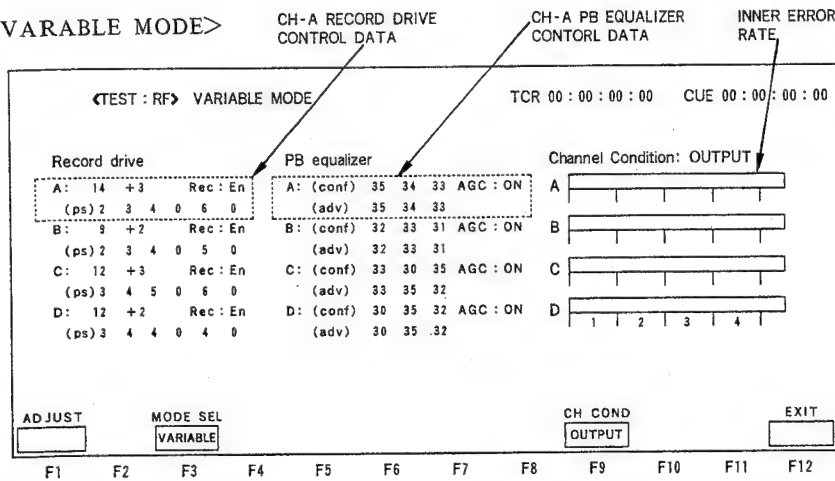

<Example 2. PRESET MODE>

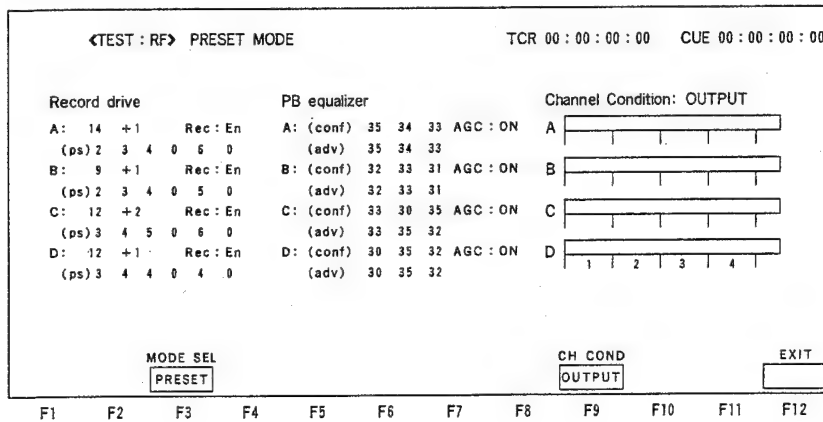

Note:

- VARIABLE mode : Adjustment of RF control data is made in this mode. The adjusted data is displayed on the screen.
- PRESET mode : The data to be adjusted is displayed on the screen.
- If the RF menu is terminated in the PRESET mode, all the data adjusted in the VARIABLE mode will be lost. To change the contents of NOVDRAM with new data, set to the VARIABLE mode, then terminate the RF menu.
- The data shown in the above examples may vary from the actual data displayed on the screen.

12-4-3. PB EQUALIZER Adjustment

Mode of DVR-1000: REC → PLAY

By pressing key **F1** (ADJUST) displayed on the "RF-15 MENU", the unit will enter the PB EQUALIZER adjustment mode. Select a channel with any key from **F3** to **F6**.

F3, **F4**, **F5**, and **F6** correspond to CH-A, CH-B, CH-C, and CH-D, respectively. The following is a description of the method of adjustment using CH-A as an example. The procedure for the other channels is identical.

Step 1.

Press the **F7** (CH.A) key. The function display will change as follows.

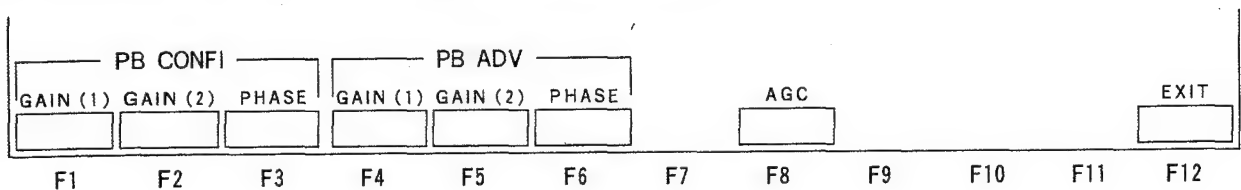

The relation between each function and the displayed data is shown in the table below.

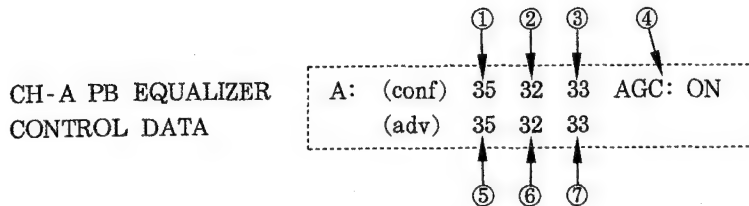

| | ADJUSTMENT | CONTROL DATA | FUNCTION KEY | REMARKS |
|---|-----------------------------|--------------|----------------------|------------------------|
| ① | CONFIDENCE PB HI-FREQ. GAIN | 0 to 63 | F1 (GAIN (1)) | TYPICAL VALUE 20~50 |
| ② | MID-&LOW-FREQ. GAIN | 0 to 63 | F2 (GAIN (2)) | |
| ③ | HI-FREQ. PHASE | 0 to 63 | F3 (PHASE) | |
| ④ | AGC CONTROL ON/OFF | *1 | F8 (AGC) | |
| ⑤ | ADVANCE PB HI-FREQ. GAIN | 0 to 63 | F4 (GAIN (1)) | TYPICAL VALUE 20~50 |
| ⑥ | MID-&LOW-FREQ. GAIN | 0 to 63 | F5 (GAIN (2)) | |
| ⑦ | HI-FREQ. PHASE | 0 to 63 | F6 (PHASE) | |

*1; Keep AGC ON at all times.

(12-4-3. PB EQUALIZER Adjustment)

Step 2. RAW ERROR MODE Setting of DVPC-1000
Turn S3 on the IF Board (TEST MODE) and also SW101-1 on the CI board ON.

Step 3. CONFIDENCE PB high freq. gain adjustment: [F1] (GAIN (1))

Put the DVR-1000 into the recording mode, then press the [F1] (GAIN (1)) key. Confirm that the function display for the [F1] key is inverted, then while observing the waveform at TP1 of the CI-01 board, turn the ADJUSTMENT control so that the INNER ERROR RATE become minimum. (When adjusting CH-B, CH-C, and CH-D, observe the waveforms at TP2, TP3, and TP4, respectively.)

INNER ERROR FLAG MONITOR
/CI-01/DVPC-1000

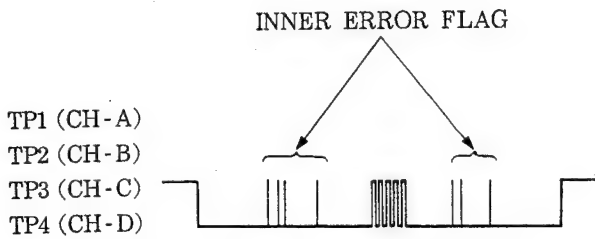

TRIG: JP3/TG-28/DVPC-1000

Spec.; INNER ERROR FLAG = Minimum
ADJUSTMENT CONTROL/FUNCTION CONT.
PNL.

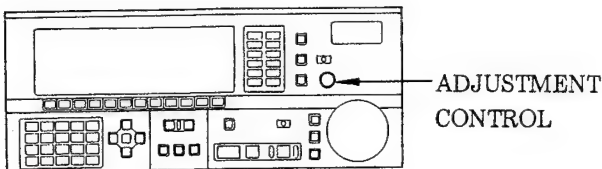

Step 4. CONFIDENCE PB low frequency gain adjustment; [F2] (GAIN (2))

Press the [F2] (GAIN (2)) key. Like Step 3, turn the ADJUSTMENT control so that the INNER ERROR RATE becomes minimum.

Step 5. CONFIDENCE PB high freq. phase adjustment: [F3] (PHASE)

Press the [F3] (PHASE) key. Like Step 3, turn the ADJUSTMENT control so that the INNER ERROR RATE becomes minimum.

Step 6.

Repeat Steps 3 to 5 several times.

Go back to Steps 3 and 4 in Section 12-3, if necessary, and make the OFFSET adjustment and the LPF adjustment.

Step 7. Loading ADVANCE PB Data

[F4], [F5], [F6]

Press the [F4] (GAIN (1)) key. A numerical value of the CONFIDENCE PB high freq. gain (GAIN (1)) is loaded as it is by the ADJUSTMENT control.

Similarly, press the [F5] (GAIN (2)) and [F6] (PHASE) keys to load a CONFIDENCE PB (GAIN (2)) value and a PHASE value.

Step 8. Checking the ADVANCE PB Error Rate

Set the DVR-1000 in playback mode and check the error rate of the ADVANCE AUDIO portion.

INNER ERROR FLAG MONITOR
/CI-01/DVPC-1000

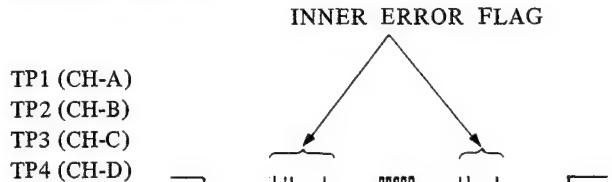

If the error rate of the ADVANCE AUDIO portion is too high, make adjustments shown in Step 9 and after.

(12-4-3. PB EQUALIZER Adjustment)

Step 9. ADVANCE PB high frequency gain adjustment:

F4 (GAIN (1))

Press the **F4** (GAIN (1)) key. Like Step 3, turn the ADJUSTMENT control so that the INNER ERROR RATE becomes minimum.

Step 10. ADVANCE PB low frequency gain adjustment:

F5 (GAIN (2))

Press the **F5** (GAIN (2)) key. Like Step 3, turn the ADJUSTMENT control so that the INNER ERROR RATE becomes minimum.

Step 11. ADVANCE PB high frequency phase adjustment:

F6 (PHASE)

Press the **F6** (PHASE) key. Like Step 3, turn the ADJUSTMENT control so that the INNER ERROR RATE becomes minimum.

Step 12.

Repeat Steps 9 to 11 several times.

Step 13

This completes the adjustments for CH-A. Press the **F12** (EXIT) key to return to the "RF-15 MENU". To adjust another channel, press the **F7** (CH.B), **F8** (CH.C), or **F9** (CH.D) key, and repeat the above procedure from Step 3.

Step 14

After completing all adjustments, perform "12-4-5 RF-15 CONTROL DATA WRITE".

Step 15. Terminating the RAW Error Mode of the DVPC-1000

Return SW101-1 on the CI board and S3 on the IF board to off.

12-4-4. RECORD DRIVE Adjustment

Mode of DVR-1000; REC

When the **[F1]** (ADJUST), **[F1]** (ADJ SEL), or **[F1]** (CONT) key is pressed on the "RF-15 MENU" (press **PLAY** and **REC** at the same time), the unit is set to RECORD DRIVE adjustment mode. Select a channel with any key from **[F3]** to **[F6]**. **[F3]**, **[F4]**, **[F5]**, and **[F6]** correspond to CH-A, CH-B, CH-C, and CH-D, respectively. The following is a description of the method of adjustment using CH-A as an example. The procedure for the other channels is identical.

Step 1.

Press the **[F3]** (CH.A) key. The function display will change as follows.

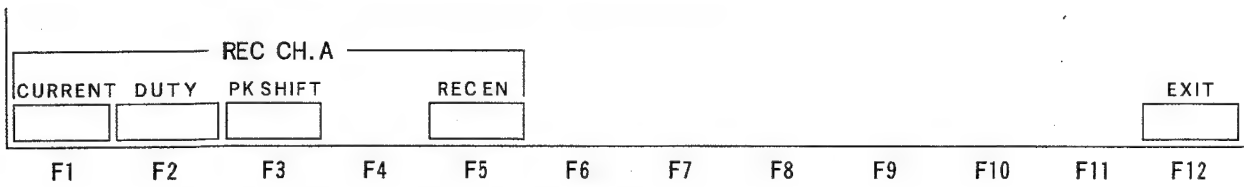

The relation between each function and the displayed data is shown in the table below.

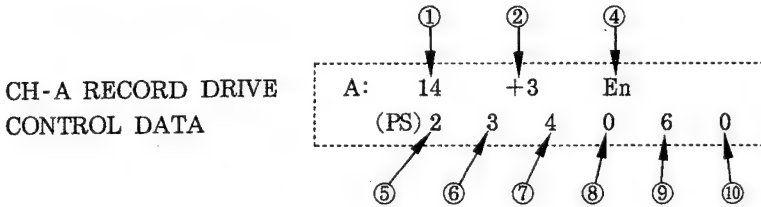

| | ADJUSTMENT | CONTROL DATA | FUNCTION KEY | REMARKS |
|---|--------------------------|---------------|---------------------------------------|--------------------|
| ① | RECORD CURRENT | 0 to 63 | [F1] (CURRENT) | |
| ② | DUTY OF DATA | -3 to +3 | [F2] (DUTY) | TYPICAL VALUE+1 |
| ④ | RECORD ENABLE | "En" or "Inh" | [F5] (ENABLE) | ALWAYS SET TO "En" |
| ⑤ | PEAK SHIFT BIT LENGTH -1 | 0 to 3 | [F3] (PK SHIFT) *See Step 5 | 0 TYPICAL VALUE |
| ⑥ | PEAK SHIFT BIT LENGTH -1 | 0 to 15 | | 0~8 4 |
| ⑦ | PEAK SHIFT BIT LENGTH -2 | | | 0~8 6 |
| ⑧ | PEAK SHIFT BIT LENGTH -4 | | | 0~8 7 |
| ⑨ | PEAK SHIFT BIT LENGTH -5 | | | 0~8 8 |
| ⑩ | PEAK SHIFT BIT LENGTH -6 | | | 0~8 8 |

↑
-2ES

(12-4-4. RECORD DRIVE Adjustment)

Step 2. Setting the RAW Error Mode of the DVPC-1000

Set S3 on the IF board to on (TEST MODE) and SW101-1 on the CI board to on.

Step 3. Record current adjustment: [F1] (CURRENT)

Press the [F1] (CURRENT) key. Confirm that the function display for the [F1] key is inverted, then while observing the waveform at TP1 of the DVPC-1000 CI-01 board, turn the ADJUSTMENT control so that the INNER ERROR RATE become minimum. (When adjusting CH-B, CH-C, and CH-D, observe the waveforms at TP2, TP3, and TP4, respectively.)

INNER ERROR FLAG MONITOR
/CI-01/DVPC-1000

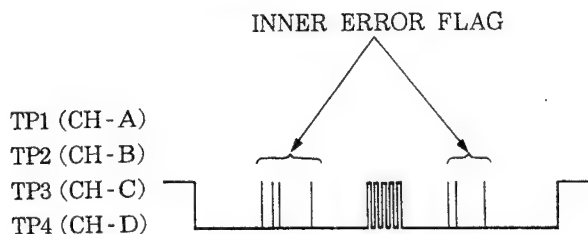

TRIG; JP3/TG-28/DVPC-1000

Spec.: INNER ERROR FLAG = Minimum
ADJUSTMENT CONTROL/FUNCTION CONT. PNL.

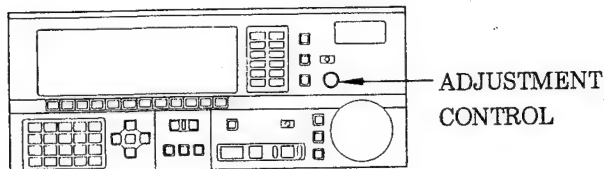

Step 4. Record data DUTY adjustment: [F2] (DUTY)

Press the [F2] (DUTY) key. Then, like Step 3, rotate the ADJUSTMENT control so that the INNER ERROR RATE becomes minimum.

Step 5. PEAK SHIFT MENU display: [F3] (PK SHIFT)

Press the [F3] (PK SHIFT) key. The function display will change as shown below.

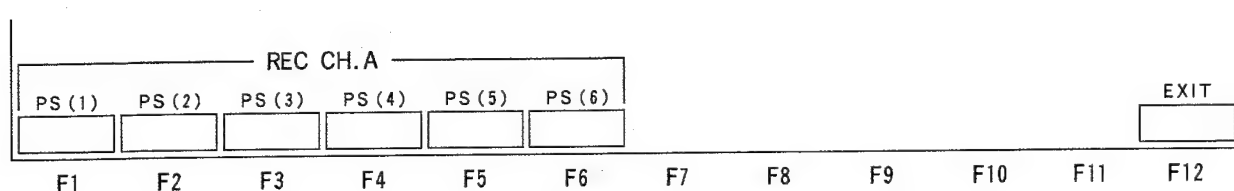

(12-4-4. RECORD DRIVE Adjustment)

Step 6. PEAK SHIFT BIT-3 LENGTH adjustment; [F1] (1)
Press the [F1] (1) key. Then, like Step 3, rotate the ADJUSTMENT control so that the INNER ERROR RATE becomes minimum.

Step 7.
Similarly, press the [F2], [F3], [F4], [F5], and [F6] keys in succession and make the PEAK SHIFT LENGTH adjustment. Adjust the bit length as follows except 0 (fixed).
Bit length $-1 \leq -2 \leq -3 \leq -4 \leq -5 \leq -6$

Step 8.
Go back to Step 3 and repeat adjustments several times.

Step 9.
Upon completion of all adjustments, press the [F12] (EXIT) key.

Step 10.
This completes the adjustments for CH-A. Press the [F12] (EXIT) key to return to the "RF-15 MENU". To adjust another channel, press the [F4] (CH.B), [F5] (CH.C), or [F6] (CH.D) key, and repeat the above procedure from Step 3.

Step 11.
After completing all adjustments, perform "12-4-5. RF-15 CONTROL DATA WRITE".

Step 12. Terminating the RAW Error Mode of the DVPC-1000
Set SW101-1 on the CI board and S3 on the IF board to off.



12-4-5. RF CONTROL DATA Write

Note;

Here, write the RF-15 CONTROL DATA that was changed in 12-4-3 and 12-4-4, to the NOVRAM. If the CPU is reset or the power switched OFF and ON again before this operation is performed, the new data will be lost. When not writing the changed data, either press the SYSTEM RESET switch S1/SP-01, or switch the power OFF and then ON again.

Step 1.

Perform the following operations from the control panel.

When HOME MENU is displayed

TEST ; TEST MENU SELECT
F3 (CHECKER); CHECKER MODE SELECT
F1 (CONTINUE)
F10 (NVW)
0
SET

When RF-15 MENU is displayed

To escape from the RF-15 menu, set to the VARIABLE mode, then perform the following key operations.

F12 (EXIT); EXIT FROM RF-15 MENU
F3 (CHECKER); CHECKER MODE SELECT
F1 (CONTINUE)
F10 (NVW)
0
SET

Step 2.

Press the key until the message "PUSH NVWR SW" appears on the control panel. The NOVRAM address and data will be displayed at the top left of the control panel. The RF-15 CONTROL DATA are written to addresses A800H to A84FH of the NOVRAM. If an address another than the above is displayed, either switch the power OFF or press the SYSTEM RESET switch S1/SP-01 and repeat the adjustment procedure from 12-4-2.

Step 3.

Press the NOVRAM WRITE switch S2/SP-01, and confirm that "READY" is displayed on the control panel. This completes the procedure for writing new data.

Step 4.

Switch the power OFF and then ON again to reset the system.

12-5. RF ENVELOPE LEVEL ADJUSTMENT

Equipment; Oscilloscope
 Mode of DVR-1000; REC→PLAY
 Setting of Switches & Controls;
 Same as Section 7-4.
 Input signal (VIDEO INPUT/DVPC-1000);
 Free

Perform the following adjustment for each of CH-A, CH-B, CH-C, and CH-D.

Adjustment RF-15 board

Step 1.

Set the DVR-1000 to the REC mode, then perform the following adjustment.

RF ENVELOPE MONITOR

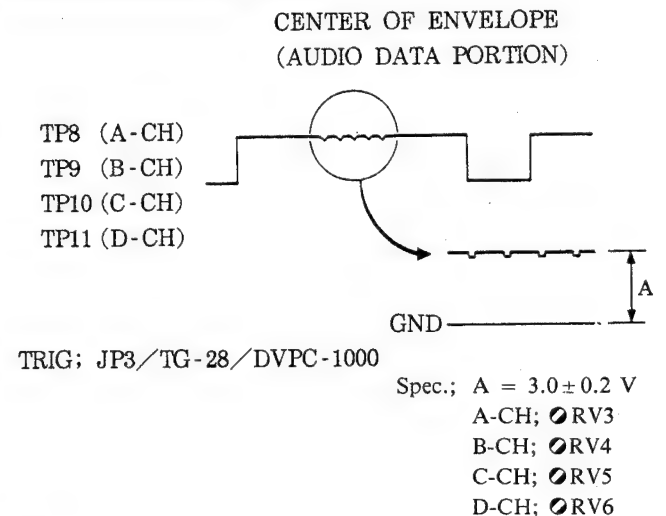

Step 2.

After turning the DVR-1000 to the manual tracking mode (turning off tracking control), play back the self-recorded tape and perform the following adjustment.

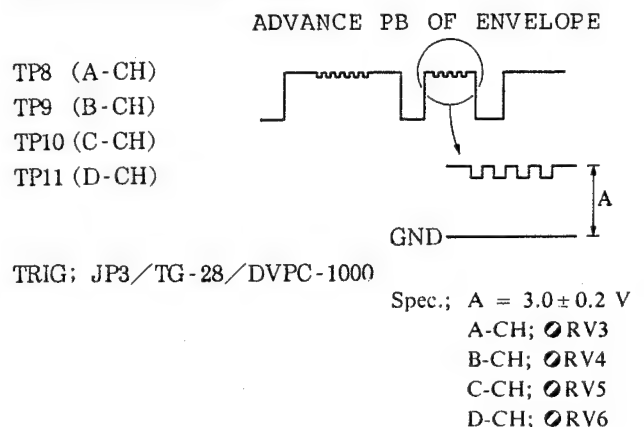

Step 3.

Adjust the parameters related with the head. In addition, check the error rate for judging whether or not operation is possible. (3.5 level should not be exceeded. Use the cleaning cassette if necessary.)

Step 4.

Play back the recorded tape. (Keep the AGC at OFF.)

Press **TEST**, **TRACKING** and **F1:AUTO** to activate auto tracking mode.

POSITION display on the EL screen moves slightly to the left and right near the screen center. In case video screen is normal, adjustment is completed.

SECTION 13 FUNCTION CONTROL PANEL ALIGNMENT

PS-139 board (component side)

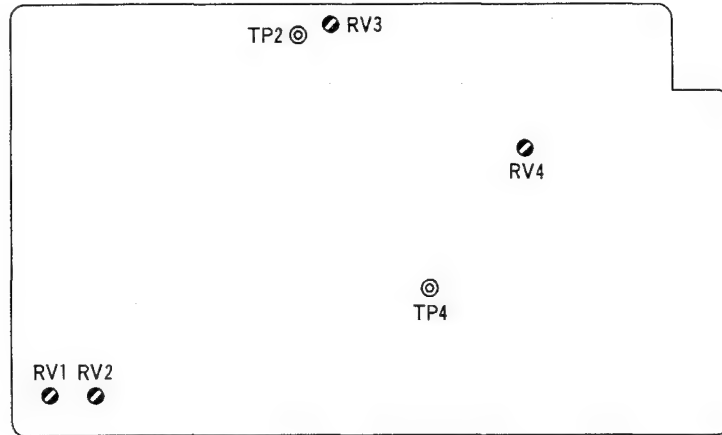

DET-3 board (component side)

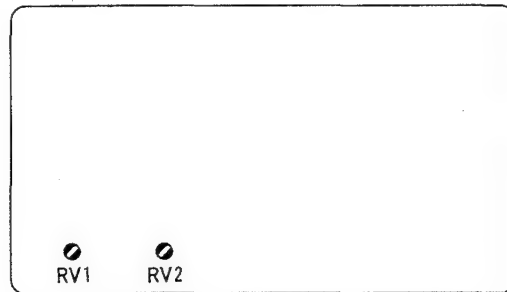

RE-44 board (component side)

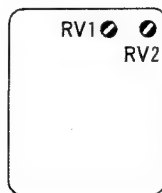

13-1. FUNCTION CONTROL PANEL ALIGNMENT SEQUENCE

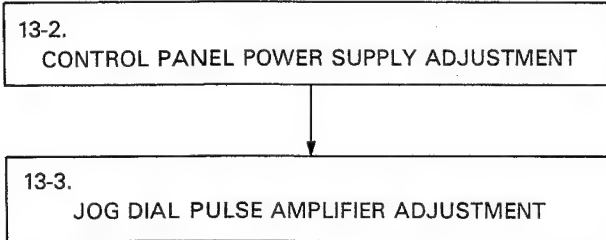

13-2. CONTROL PANEL POWER SUPPLY ADJUSTMENT

Equipment; Digital voltmeter

After replacing the following controls, set them to the positions indicated below before re-adjusting them.

- RV1; Fully clockwise
- RV2; Fully counterclockwise
- RV3; Fully clockwise
- RV4; Fully counterclockwise

Step 1. +5 V voltage adjustment

TP4/PS-139 = $+5.00 \pm 0.05$ Vdc
RV3/PS-139

Step 2. +5 V limiter current adjustment

Obtain the following load resistor and perform the adjustment of (1).

Resistance value = 2 ohms
Rated wattage = 20 W

If the above resistor is not available, perform the adjustment of (2).

- (1) Switch the power OFF, then remove CN509 from the PS-139 board.
Connect a 2 ohm/20 W resistor between TP4/PS-139 and GND. Switch the power ON, then while observing the waveform at TP4/PS-139 gradually rotate RV4/PS-139 until the output of TP4 starts to change. After adjustment, disconnect the resistor and connect CN509.
- (2) Set RV4/PS-139 to the following position.

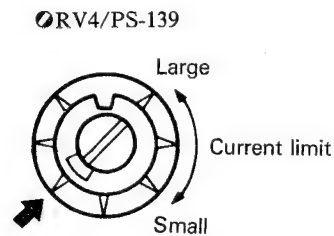

Step 3. +15 V voltage adjustment

TP2/PS-139 = +15.00 ± 0.05 Vdc
RV1/PS-139

Step 4. +15 V limiter current adjustment

Obtain the load resistor shown below and perform the adjustment of (1).

Resistance value = 15 ohms

Rated wattage = 20 W

If the above resistor is not available, perform the adjustment of (2).

- (1) Switch the power OFF, then pull out CN509 from the PS-139 board.

Connect a 15 ohm/20 W resistor between TP2/PS-139 and GND. Switch the power ON, then while observing the waveform at TP2/PS-139 gradually rotate RV2/PS-139 until the output from TP2 starts to change. After adjustment, disconnect the resistor and connect CN509.

- (2) Set RV2 to the following position.

RV2/PS-139

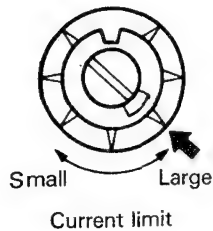

13-3. JOG DIAL PULSE AMPLIFIER ADJUSTMENT

Equipment; Oscilloscope

Step 1. Adjustment

Enter the JOG mode, then while rotating the search dial turn RV1 on the DET-3 board left and right. Set RV1 to the point mid-way between the point at which a pulse appears at pin 14 of IC4 of SW-157 board when RV1 is turned to the left, and the point at which the pulse appears when RV1 is turned to the right.

Step 2.

Enter the JOG mode, then like Step 1, adjust RV2 of the DET-3 board with respect to the output from pin 13 of IC4 of the SW-157 board.

Step 3.

Rotate the search dial in the FWD direction. Check the phases of pins 14 and 13 of IC4.

Pin 14/IC4/
SW-157



Pin 13/IC4/
SW-157



Step 4.

Rotate the search dial in the REV direction. Check the phases of pins 14 and 13 of IC4.

Pin 14/IC4/
SW-157



Pin 13/IC4/
SW-157



13-4. ROTARY ENCODER PULSE AMPLIFIER ADJUSTMENT

The adjustment is required only for machines with the following serial numbers.

DVR-1000 (J) : # 10001- # 10599

DVR-1000 (UC) : # 10001- # 10699

DVR-1000 (EK) : # 10001- # 10699

Equipment; Digital voltmeter

Adjustment

Pin 6/IC1/RE-44 = 2.00 ± 0.05 V
 RV1/RE-44

Pin 2/IC1/RE-44 = 2.00 ± 0.05 V
 RV2/RE-44

SONY

DIGITAL CASSETTE VTR

DVR-1000

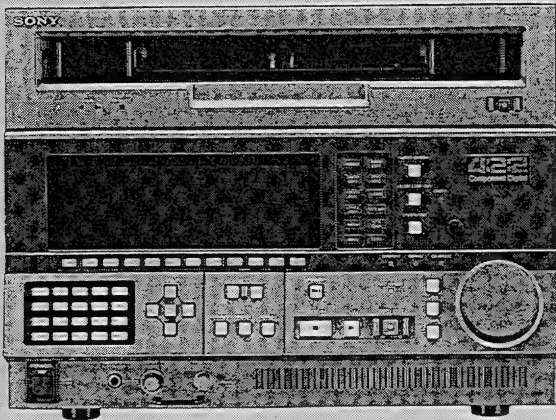

4:2:2

Component Digital

MAINTENANCE MANUAL

Volume 2 2nd Edition (Revised 2)

Serial No.33001 and Higher (J)

Serial No.32101 and Higher (UC)

Serial No.32201 and Higher (EK)

このマニュアルに記載されている事柄の著作権は当社にあり、説明内容は機器購入者の使用を目的としています。従って、当社の許可なしに無断で複写したり、説明内容(操作、保守等)と異なる目的で本マニュアルを使用することを禁止します。

The material contained in this manual consists of information that is the property of Sony Corporation and is intended solely for use by the purchasers of the equipment described in this manual.

Sony Corporation expressly prohibits the duplication of any portion of this manual or the use thereof for any purpose other than the operation or maintenance of the equipment described in this manual without the express written permission of Sony Corporation.

Le matériel contenu dans ce manuel consiste en informations qui sont la propriété de Sony Corporation et sont destinées exclusivement à l'usage des acquéreurs de l'équipement décrit dans ce manuel.

Sony Corporation interdit formellement la copie de quelque partie que ce soit de ce manuel ou son emploi pour tout autre but que des opérations ou entretiens de l'équipement à moins d'une permission écrite de Sony Corporation.

Das in dieser Anleitung enthaltene Material besteht aus Informationen, die Eigentum der Sony Corporation sind, und ausschließlich zum Gebrauch durch den Käufer der in dieser Anleitung beschriebenen Ausrüstung bestimmt sind.

Die Sony Corporation untersagt ausdrücklich die Vervielfältigung jeglicher Teile dieser Anleitung oder den Gebrauch derselben für irgendeinen anderen Zweck als die Bedienung oder Wartung der in dieser Anleitung beschriebenen Ausrüstung ohne ausdrückliche schriftliche Erlaubnis der Sony Corporation.

目次 TABLE OF CONTENTS

Volume-1

1. 設置
2. サービスインフォメーション
3. テストメニュー
5. 定期点検および保守
6. 部品交換と調整
7. 調整のための一般情報
8. 電源調整
9. テープ走行系調整
10. サーボ系調整
11. アナログ信号系調整
12. RF信号系調整
13. ファンクションコントロールパネル調整

1. INSTALLATION
2. SERVICE INFORMATION
3. TEST MENU
5. PERIODICAL INSPECTION AND MAINTENANCE
6. PARTS REPLACEMENT AND ADJUSTMENT
7. GENERAL INFORMATION FOR ALIGNMENT
8. POWER SUPPLY ALIGNMENT
9. TAPE PATH SYSTEM ALIGNMENT
10. SERVO SYSTEM ALIGNMENT
11. ANALOG SIGNAL SYSTEM ALIGNMENT
12. RF SIGNAL SYSTEM ALIGNMENT
13. FUNCTION CONTROL PANEL ALIGNMENT

Volume-2

A. BLOCK DIAGRAMS

| | |
|--|------|
| Overall | A-1 |
| RF-15 Board; RF | A-4 |
| AE-05 Board; Audio (CUE/CTL) & Erase | A-7 |
| CD-35 Board; Capstan & Drum Servo | A-11 |
| RS-23 Board; Reel Servo | A-15 |
| CS-27 Board; Auto Tracking | |
| SP-01 Board; Servo Processor | A-19 |
| SY-124 Board; System Controller | A-23 |
| Interface | |
| IF-134 Board; RS-422 Interface Board | |
| IF-135 Board; GP-IB Interface Board | |
| IF-138 Board; Interface Mother Board | |
| IF-210 Board; RS-232C Interface Board | A-31 |
| IF-221 Board; Parallel I/O Interface Board | A-33 |
| Function Control Panel | A-35 |
| CP-106 Board; Function Control Panel | |
| DET-3 Board; Search Dial Detector | |
| PS-139 Board; Power Supply | |
| RE-44 Board; Rotary Encoder Detector | |
| SW-157 Board; Switch | |
| SW-158 Board; Switch | |
| MD-43 Board; Mother Driver | A-39 |
| Power Supply | A-43 |
| CT-74 Board; Regulator Controller | |
| PS-138 Board; Power Supply | |
| RE-32 Board; Switching Regulator | |

B. SCHEMATIC DIAGRAMS & BOARD LAYOUT

CARD RACK

| | |
|--|------|
| RF-15 Board; RF | B-4 |
| AE-05 Board; Audio (CUE/CTL) & Erase | B-10 |
| CD-35 Board; Capstan & Drum Servo | B-24 |
| RS-23 Board; Reel Servo | B-31 |
| CS-27 Board; Auto Tracking | |
| SP-01 Board; Servo Processor | B-39 |
| SY-124 Board; System Controller | B-47 |
| LO-05 Board; Audio Line Out | B-62 |
| TR-40 Board; Input Transformer | B-68 |
| PR-87 Board; Processor Interface (CN-A) | B-73 |
| Interface | |
| IF-135 Board; GP-IB Interface Board (CN-B) | |
| IF-134 Board; RS-422 Interface Board | |
| IF-138 Board; Interface Mother Board | |
| IF-210 Board; RS-232C Interface Board | B-82 |
| IF-211 Board; Parallel I/O Interface Board | B-85 |

| | |
|--|-------|
| Function Control Panel | B-89 |
| CP-106 Board; Function Control Panel | |
| DET-3 Board; Search Dial Detector | |
| PS-139 Board; Power Supply Relaying | |
| RE-44 Board; Rotary Encoder Detector | |
| SW-157 Board; Switch | |
| SW-158 Board; Switch | |
| MD-43 Board; Motor Driver | B-97 |
| PD-36 Board; Power Rotary Trans Driver | B-97 |
| Power Supply | B-105 |
| PS-138 Board; Power Supply | |
| CT-74 Board; Regulator Controller | |
| RE-32 Board; Switching Regulator | |
| MB-133 Board; Mother Board | B-113 |
| Frame Wiring (1/2) | B-121 |
| CS-21 Board; Cassette Controller (FIX) | |
| CC-29 Board; Cassette Controller (MOVE) | |
| LE-52 Board; Coding Hole Sensor (LED) | |
| LE-56 Board; Indicator (LOAD & RUN) | |
| PC-34 Board; Sensor, User Hole & Reel Position | |
| PC-37 Board; Sensor, Cassette In/Up/Down | |
| PE-18 Board; Power Indicator | |
| SE-47 Board; Sensor Relaying | |
| SW-179 Board; Eject Switch | |
| TR-41 Board; Coding Hole Sensor (PTR) | |
| Frame Wiring (2/2) | B-129 |
| AH-13 Board; R/P Head | |
| AH-15 Board; Full Erase Head | |
| BP-10 Board; Relaying | |
| CN-157 Board; Reel Motor Relaying | |
| CN-191 Board; BNC Panel | |
| DE-17 Board; Tension Sensor | |
| FC-37 Board; Power Supply Relaying | |
| FP-24 Board; Control Panel Relaying | |
| MB-137 Board; Motor Drive Mother Board | |
| PC-36 Board; Tape End/Beginning Sensor | |
| VR-50 Board; Volume | |

C. SEMICONDUCTOR PIN ASSIGNMENT

| | |
|---------------------------|------|
| Semiconductor Index | C-1 |
| Diode | C-3 |
| Transistor | C-3 |
| IC | C-5 |
| PROM | C-44 |
| GAL | C-45 |

D. REPLACEABLE PARTS & OPTIONAL FIXTURE

| | |
|--|------|
| Notes on Repair Parts | D-1 |
| Main Ass'y | D-2 |
| Front Panel Ass'y | D-7 |
| Function Control Panel Ass'y | D-8 |
| Rear Panel Ass'y | D-13 |
| Power Ass'y | D-14 |
| Cassette Compartment Ass'y | D-19 |
| Reel Table Ass'y | D-20 |
| S Side Guides & Pinch Roller Ass'y | D-25 |
| T Side Guides & Capstan Ass'y | D-26 |
| Slant Guide, Threading Motor & Driving Shaft | D-31 |
| Head Drum Ass'y | D-32 |
| Nonpolar Capacitor | D-37 |
| Electrolytic Capacitor | D-37 |
| Resistor | D-38 |
| AE-05 Board | D-39 |
| AH-13 Board | D-42 |
| AH-15 Board | D-43 |
| BP-10 Board | D-43 |
| CC-29 Board | D-44 |
| CD-35 Board | D-44 |
| CN-157 Board | D-46 |
| CN-191 Board | D-46 |
| CP-106 Board | D-47 |
| CS-21 Board | D-47 |
| CS-27 Board | D-48 |
| CT-74 Board | D-48 |
| DE-17 Board | D-49 |
| DET-3 Board | D-49 |
| FC-37 Board | D-50 |
| FP-24 Board | D-50 |
| IF-134 Board | D-51 |
| IF-135 Board | D-51 |
| IF-138 Board | D-52 |
| IF-221 Board | D-52 |
| LE-52 Board | D-53 |
| LE-56 Board | D-54 |
| LO-05 Board | D-54 |
| MB-133 Board | D-55 |
| MB-137 Board | D-56 |
| MD-43 Board | D-56 |

| | |
|---|------|
| PC-34 Board | D-58 |
| PC-36 Board | D-59 |
| PC-37 Board | D-59 |
| PD-36 Board | D-60 |
| PE-18 Board | D-60 |
| PR-87 Board | D-61 |
| PS-138 Board | D-61 |
| PS-139 Board | D-63 |
| RE-32 Board | D-64 |
| RE-44 Board | D-65 |
| RF-15 Board | D-66 |
| RS-23 Board | D-67 |
| SE-47 Board | D-69 |
| SP-01 Board | D-69 |
| SW-157 Board | D-70 |
| SW-158 Board | D-71 |
| SW-179 Board | D-72 |
| SY-124 Board | D-72 |
| TR-40 Board | D-74 |
| TR-41 Board | D-75 |
| VR-50 Board | D-75 |
| Frame | D-76 |
| Frame/Function Control Panel | D-79 |
| Accessories Supplied <input type="checkbox"/> | D-80 |
| IF-210 Board <input type="checkbox"/> | D-80 |
| Optional Fixture | D-80 |

E. CHANGED PARTS

SECTION A
BLOCK DIAGRAMS

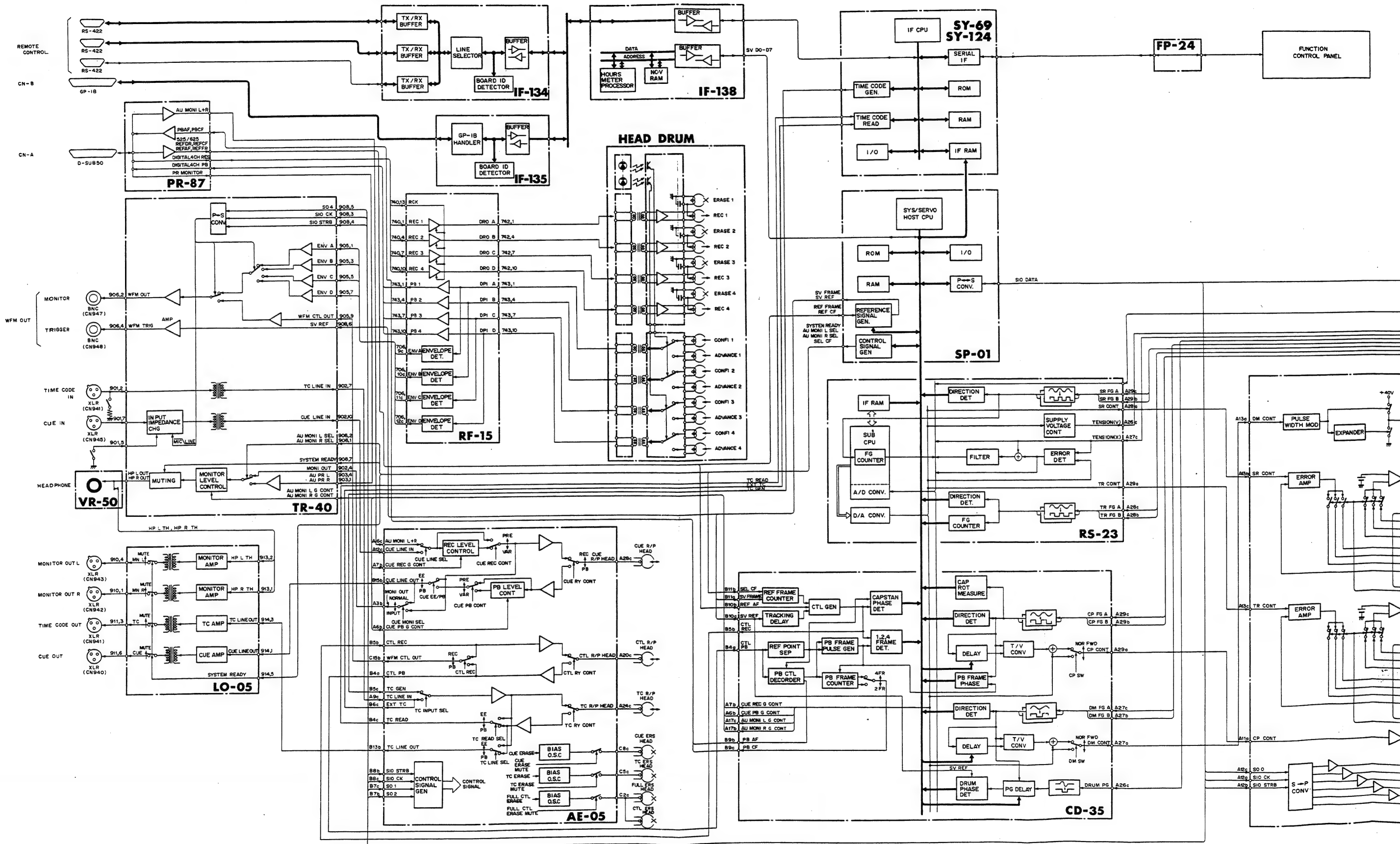

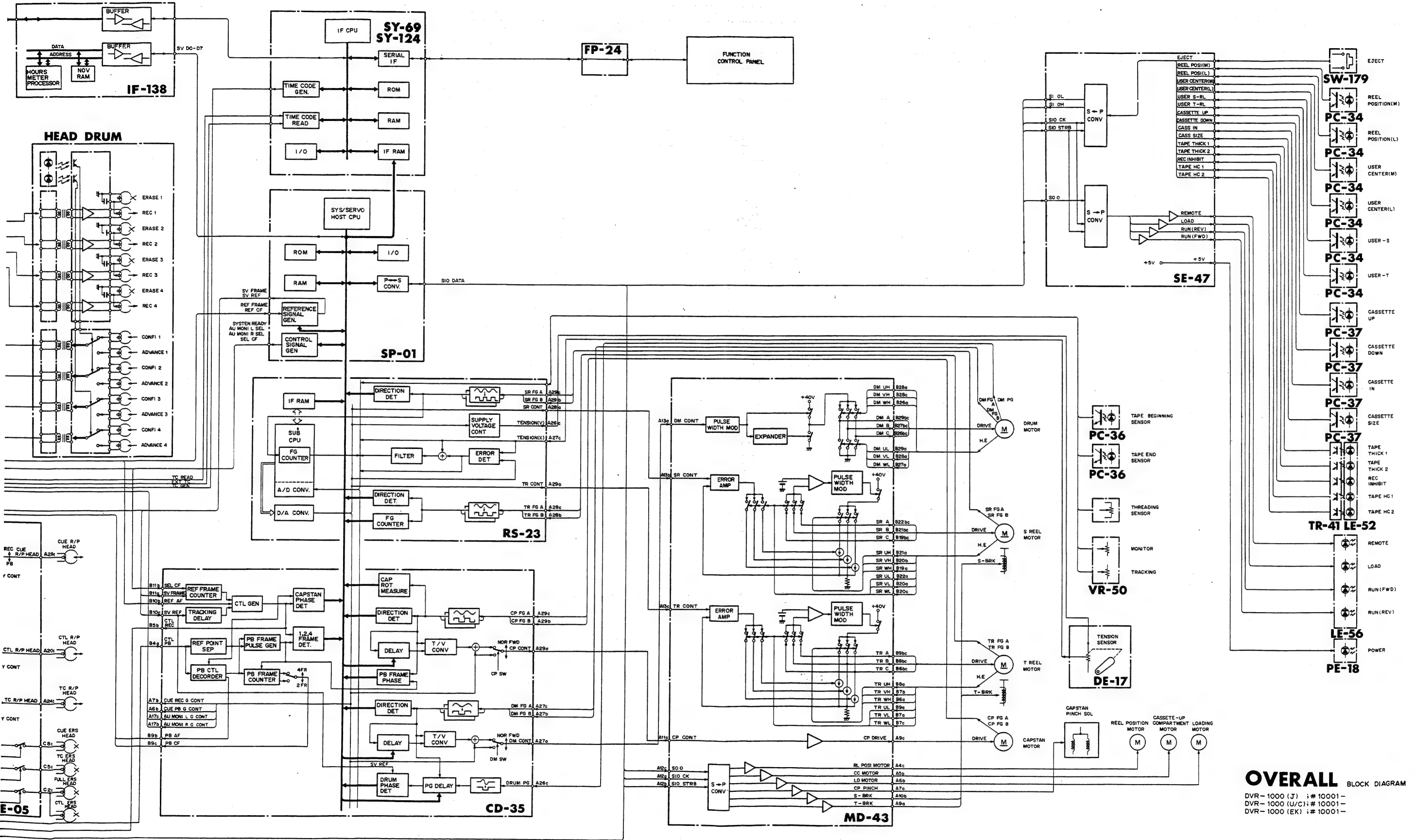

OVERALL BLOCK DIAGRAM
 DVR-1000 (J) ; #10001-
 DVR-1000 (U/C) ; #10001-
 DVR-1000 (EK) ; #10001-

RF-15 BOARD
RF

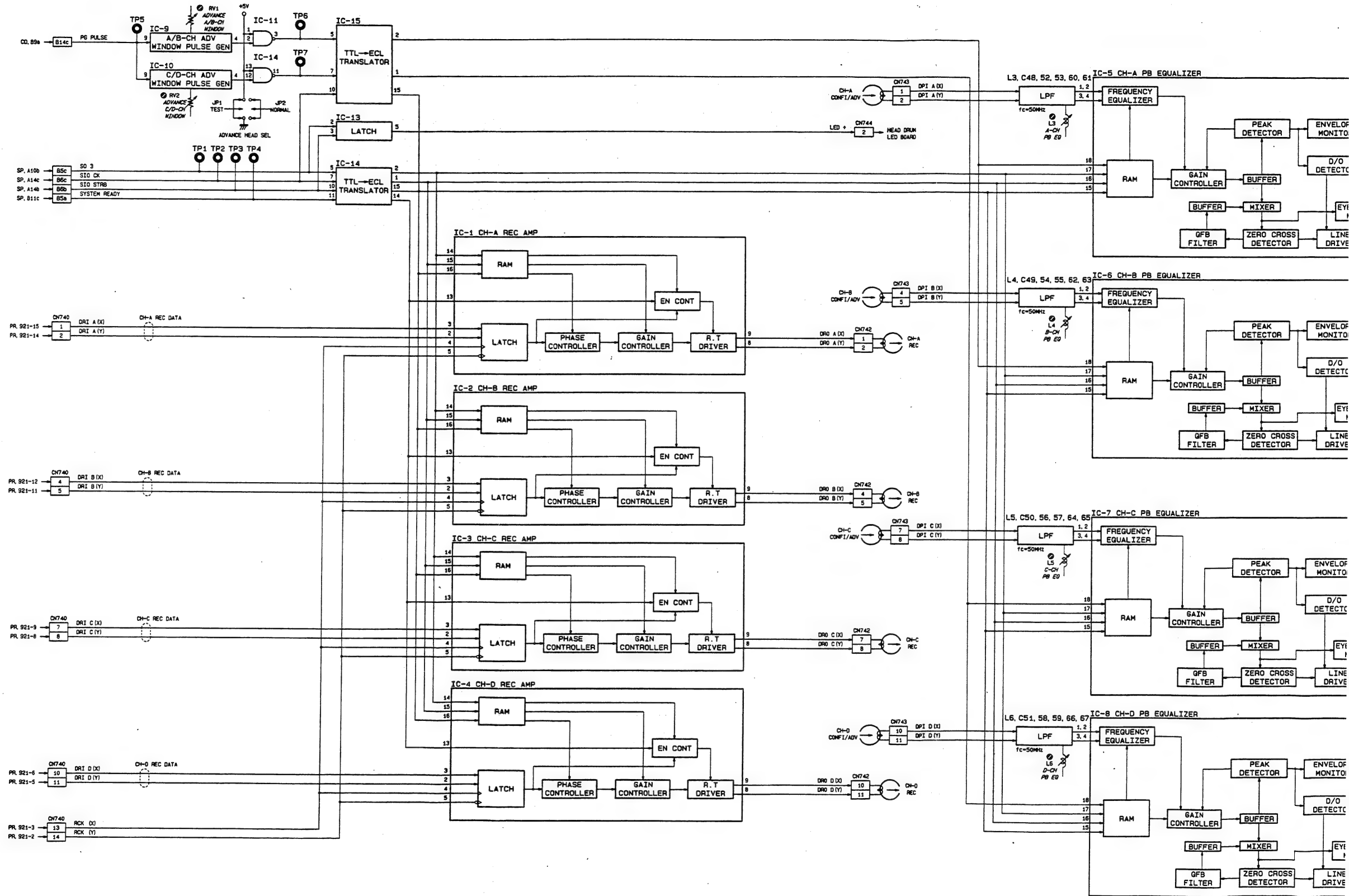

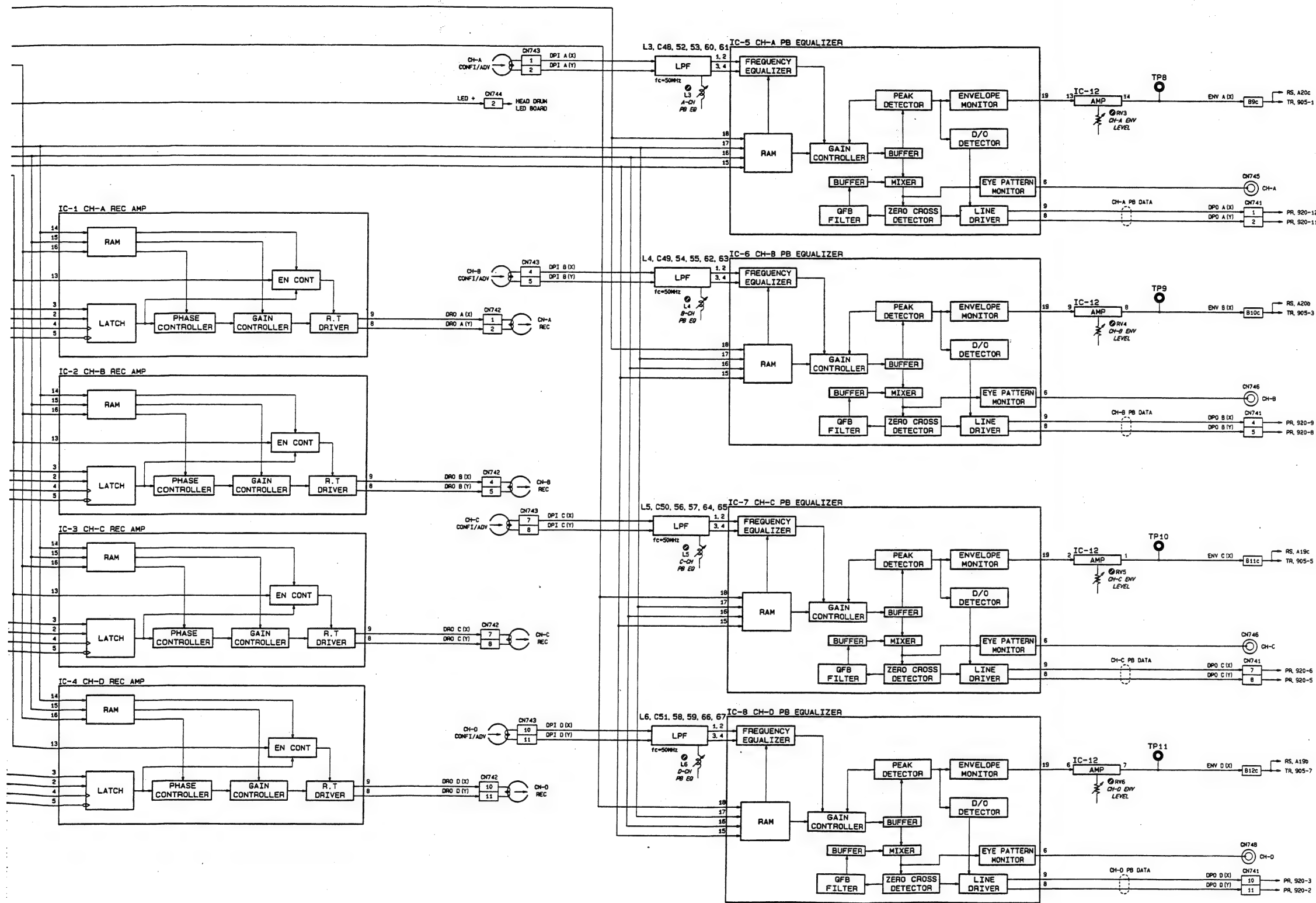

RF-15 BOARD BLOCK DIAGRAM
 BOARD NO. 1-620-901-11, 12, 13
 DVR-1000 (J) : #10001-
 DVR-1000 (U/C) : #10001-
 DVR-1000 (EK) : #10001-

BLOCK DIAGRAM AE-05 AE-05 BLOCK DIAGRAM

AE-05 BOARD
Audio (CUE/CTL) & Erase

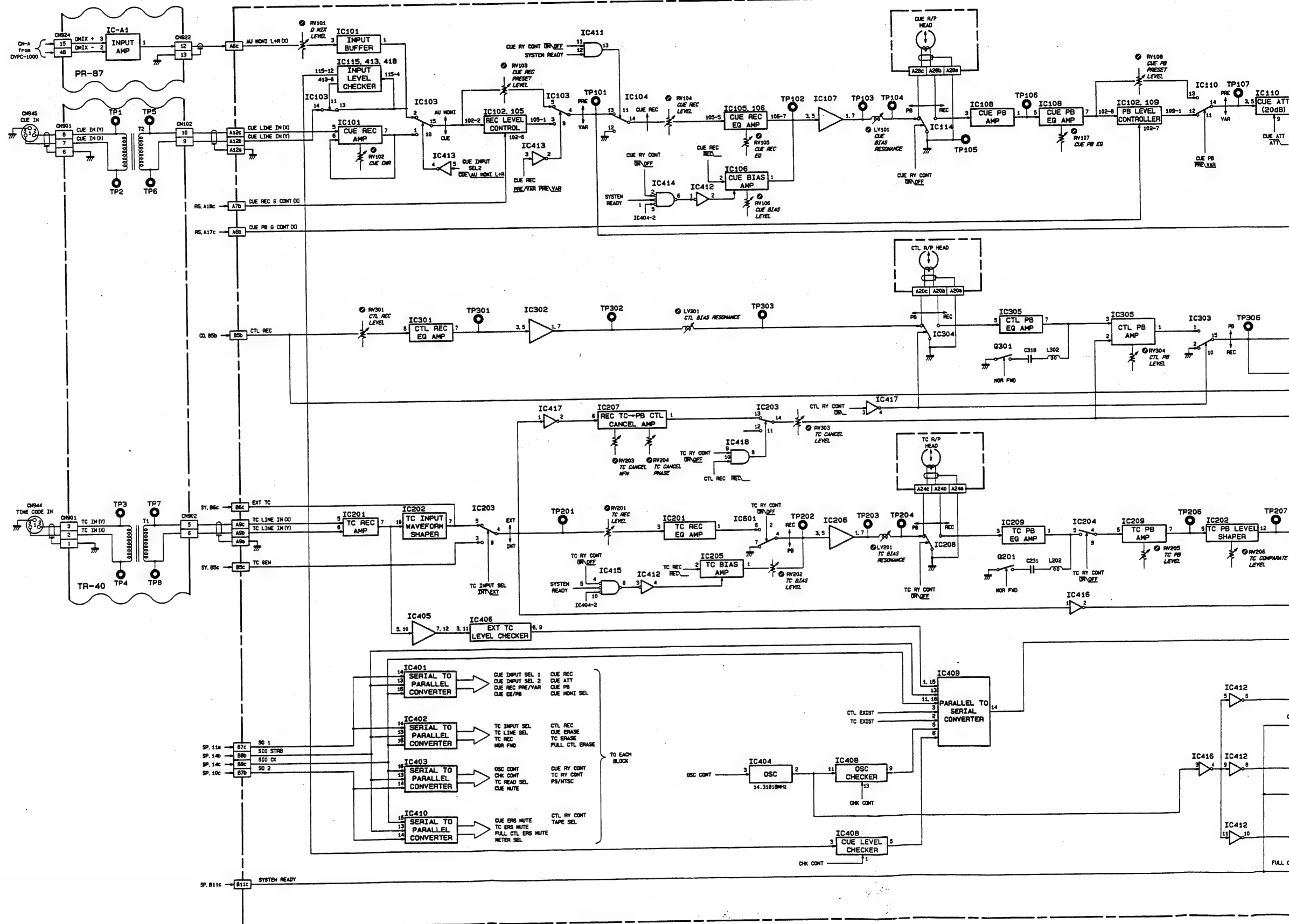

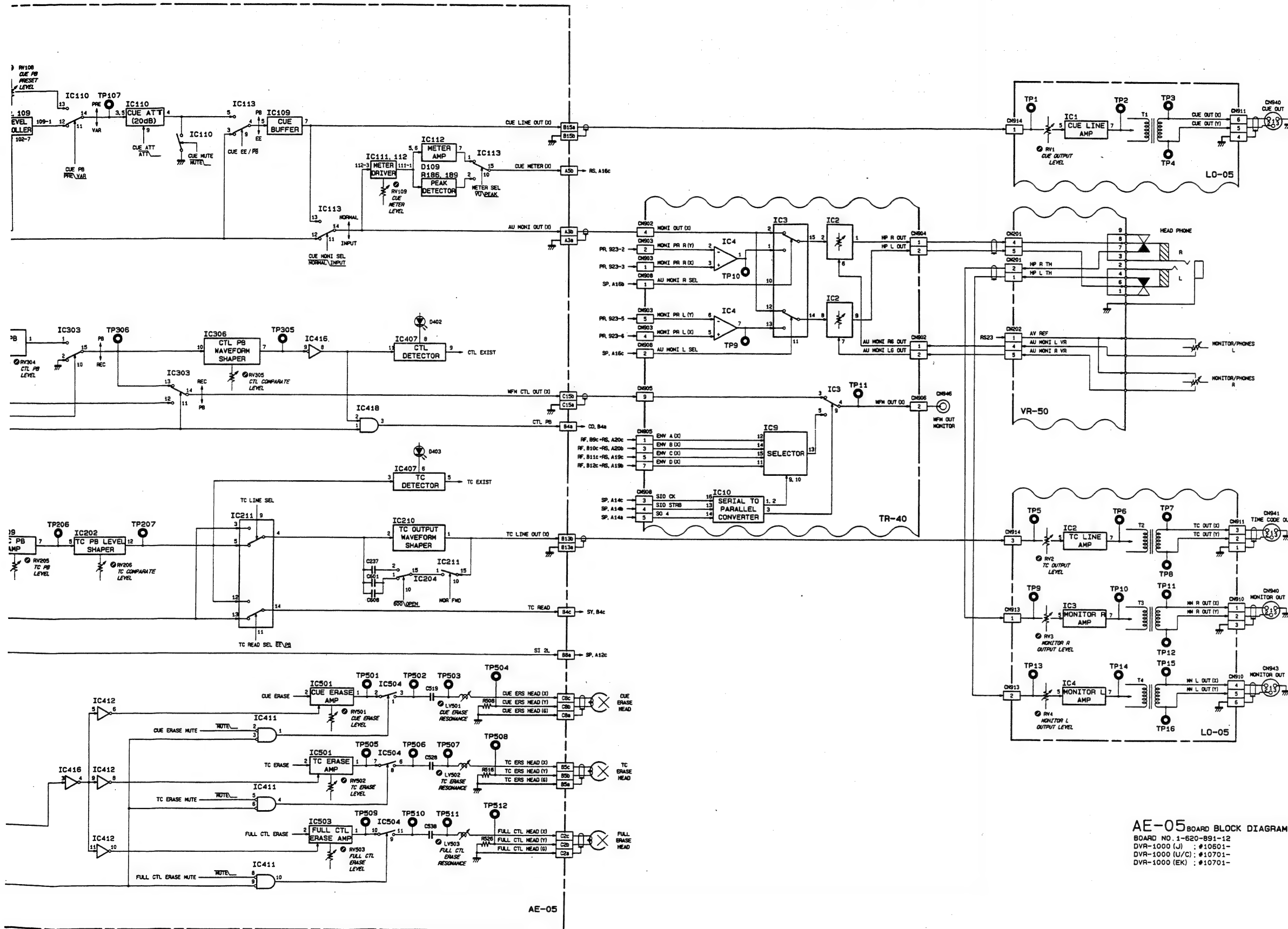

AE-05 BOARD BLOCK DIAGRAM
 BOARD NO. 1-620-891-12
 DVR-1000 (J) : #10601-
 DVR-1000 (U/C) : #10701-
 DVR-1000 (EK) : #10701-

CD-35 BOARD
Capstan & Drum Servo

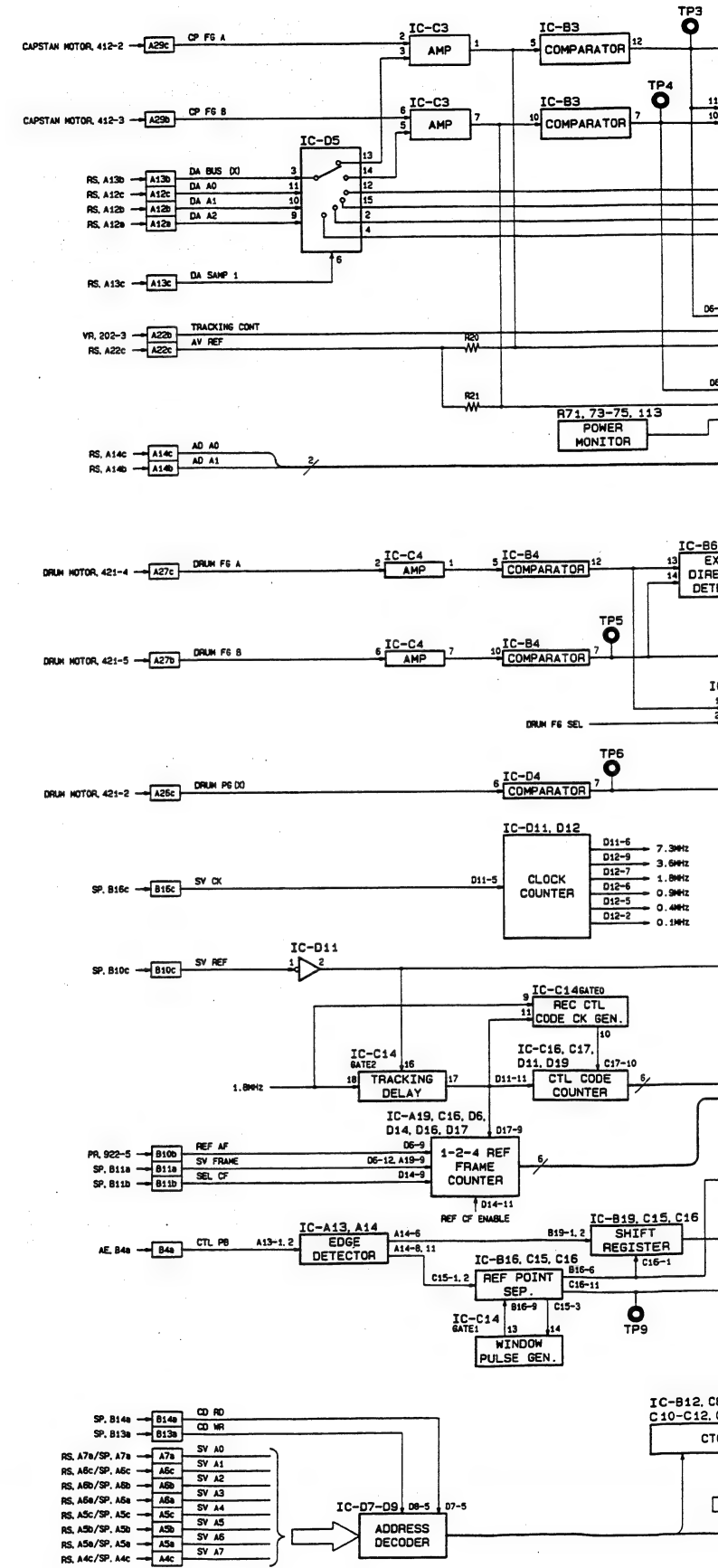

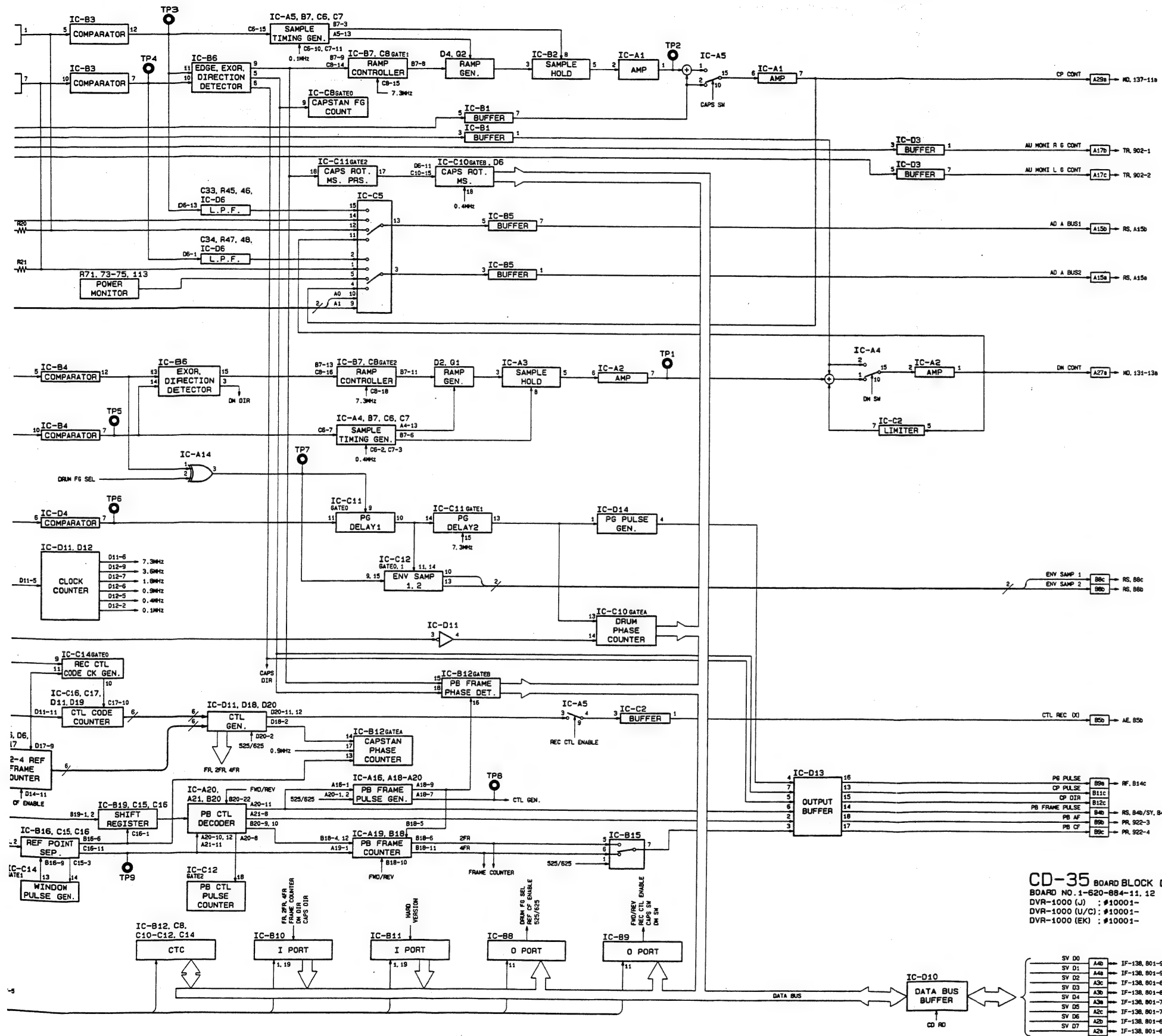

CD-35 BOARD BLOCK DIAGRAM
 BOARD NO. 1-620-884-11, 12
 DVR-1000 (J) : #10001-
 DVR-1000 (U/C) : #10001-
 DVR-1000 (EK) : #10001-

| | | |
|-------|-----|--------------------------------|
| SV D0 | A4B | IF-138, 801-98/RS, A4B/SP, A4B |
| SV D1 | A4B | IF-138, 801-98/RS, A4B/SP, A4B |
| SV D2 | A3C | IF-138, 801-98/RS, A3C/SP, A3C |
| SV D3 | A3C | IF-138, 801-98/RS, A3C/SP, A3C |
| SV D4 | A3C | IF-138, 801-98/RS, A3C/SP, A3C |
| SV D5 | A2C | IF-138, 801-7A/RS, A2C/SP, A2C |
| SV D6 | A2C | IF-138, 801-6B/RS, A2C/SP, A2C |
| SV D7 | A2C | IF-138, 801-6A/RS, A2C/SP, A2C |

RS-23 BOARD : Reel Servo
CS-27 BOARD : Auto Tracking

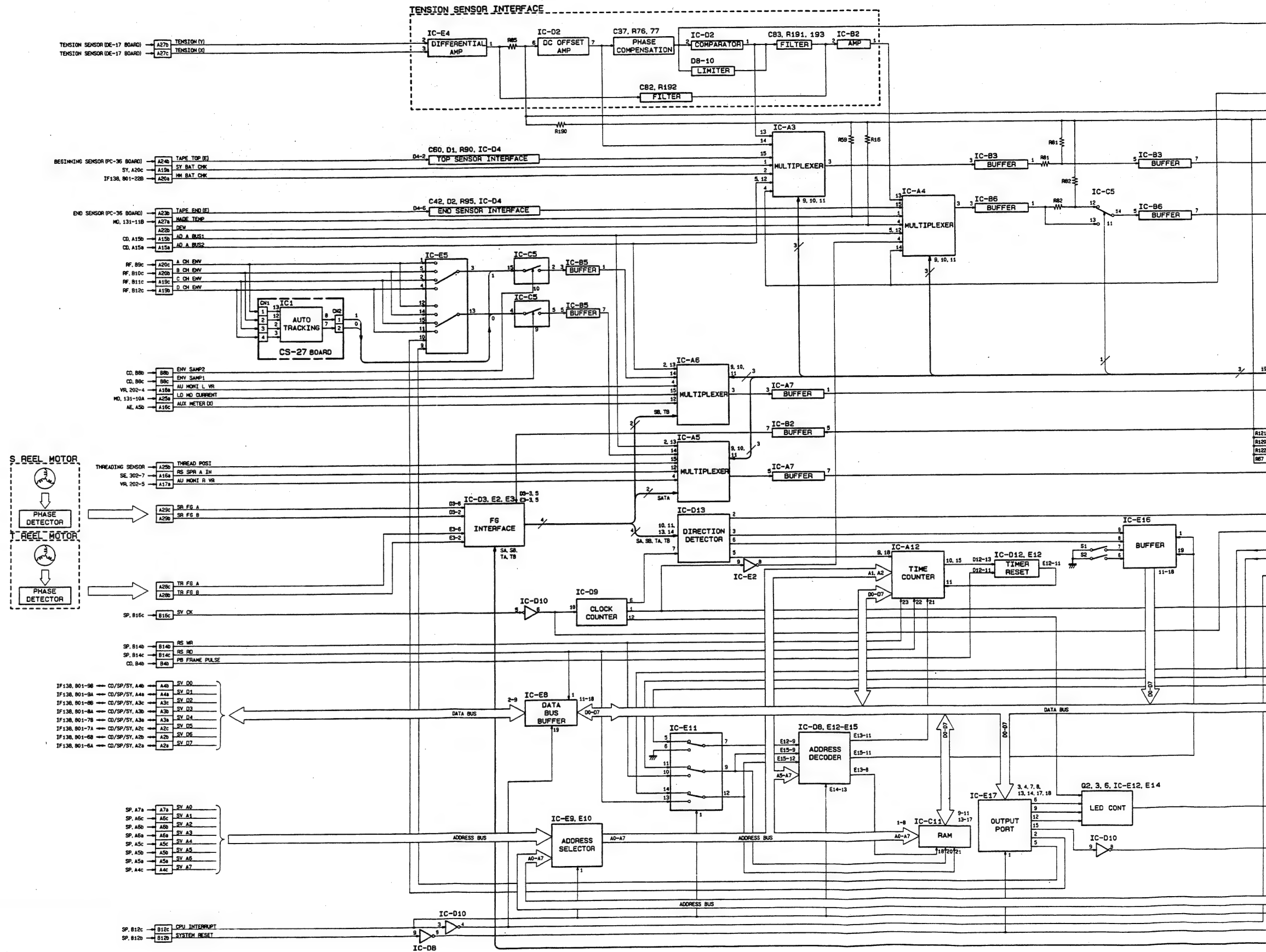

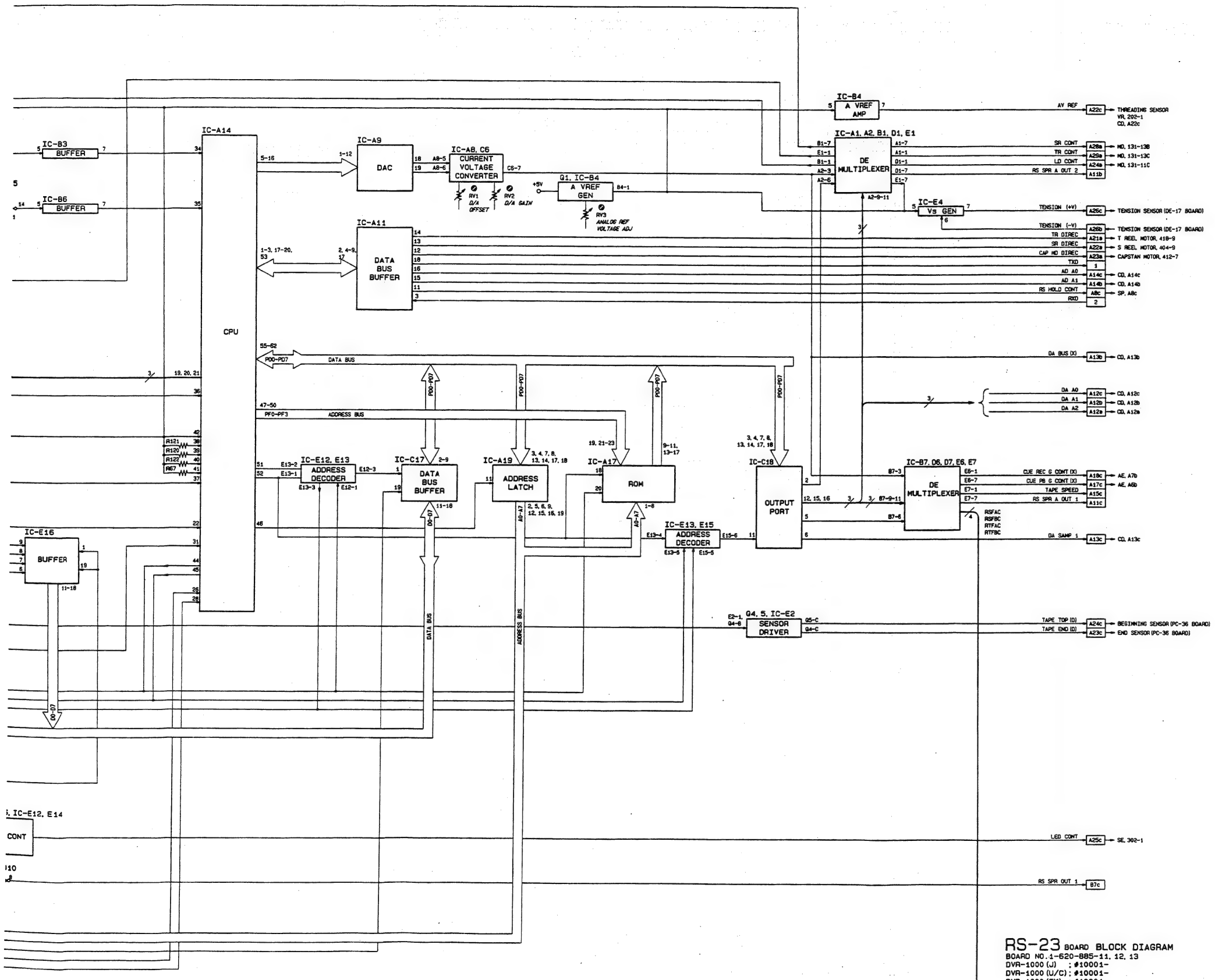

RS-23 BOARD BLOCK DIAGRAM
 BOARD NO. 1-620-885-11, 12, 13
 DVR-1000 (J) : #10001-
 DVR-1000 (U/C) : #10001-
 DVR-1000 (EK) : #10001-

SP-01 BOARD
Servo Processor

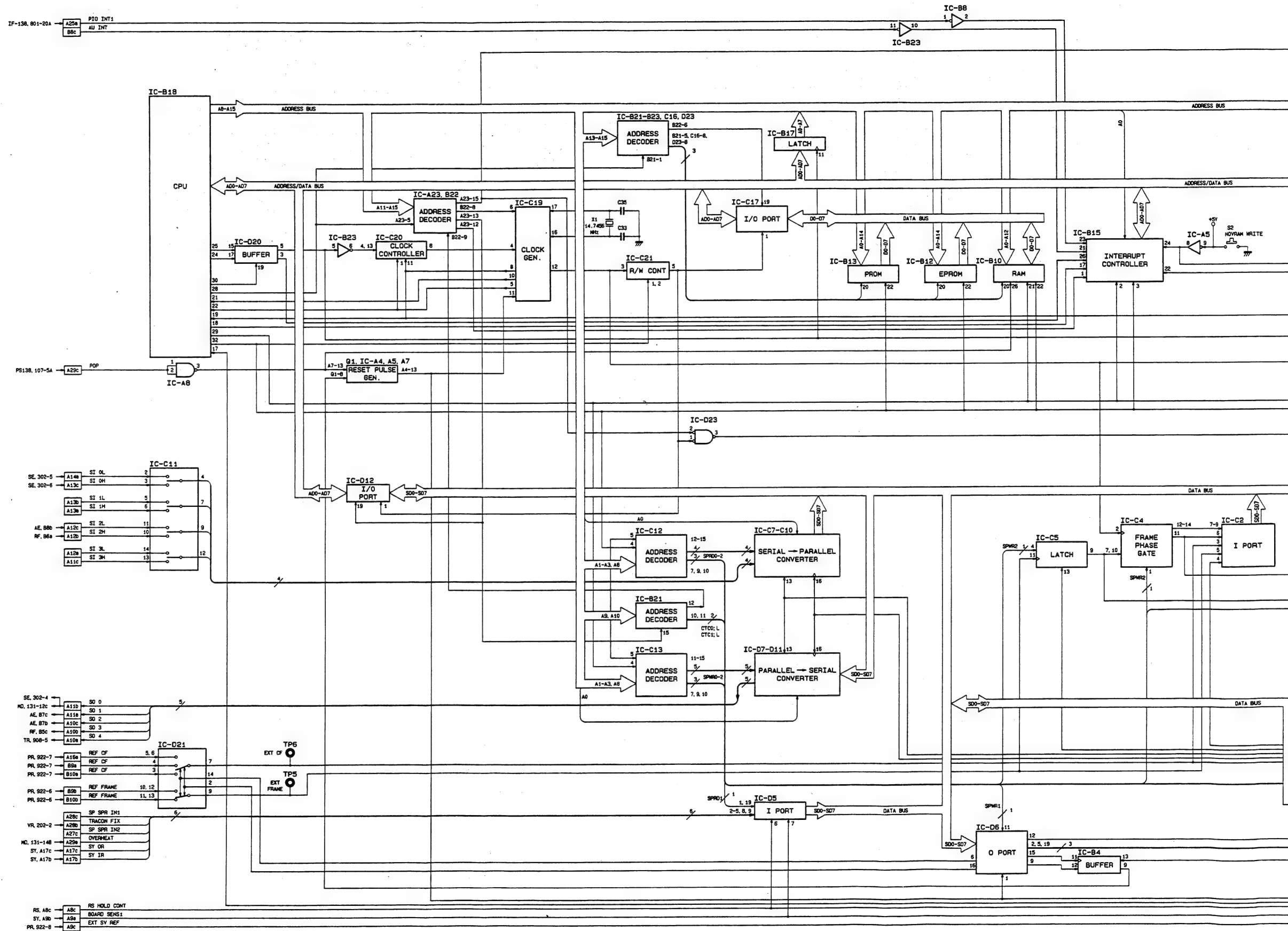

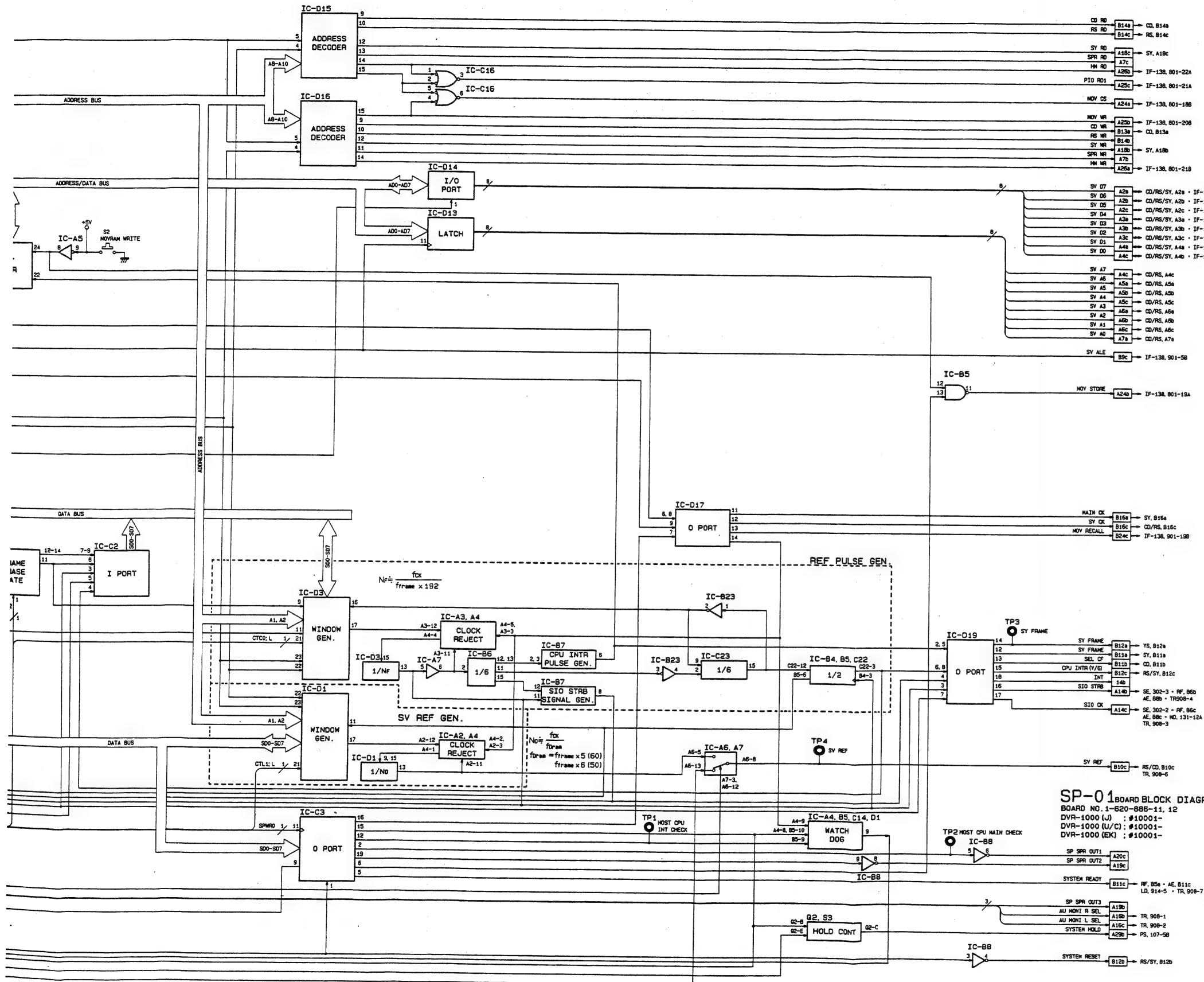

SP-01 BOARD BLOCK DIAGRAM
 BOARD NO. 1-620-886-11, 12
 DVR-1000 (L) ; #10001-
 DVR-1000 (L/C) ; #10001-
 DVR-1000 (EK) ; #10001-

SY-124 BOARD
System Controller

BLOCK DIAGRAM SY-124 **SY-124 BLOCK DIAGRAM**

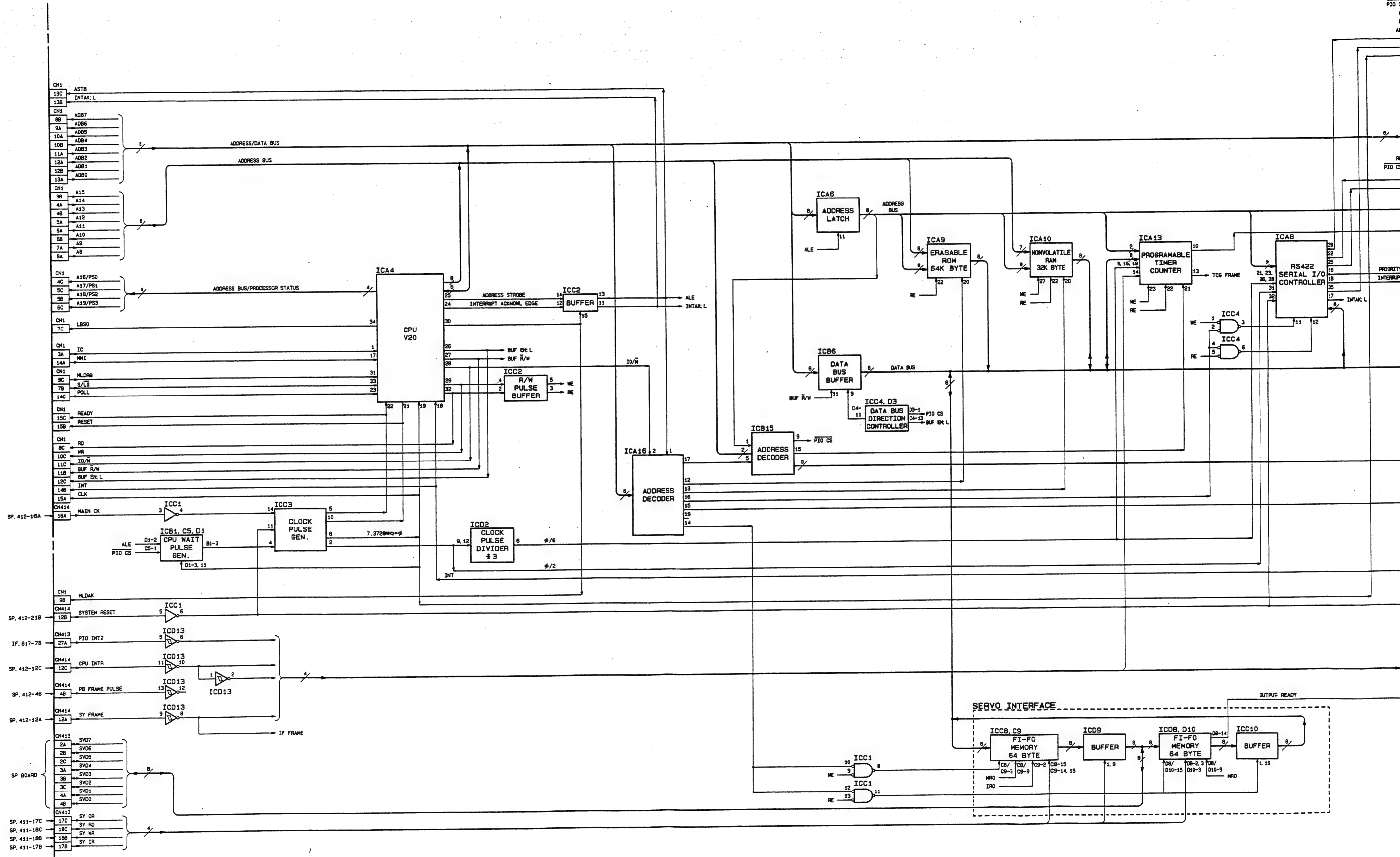

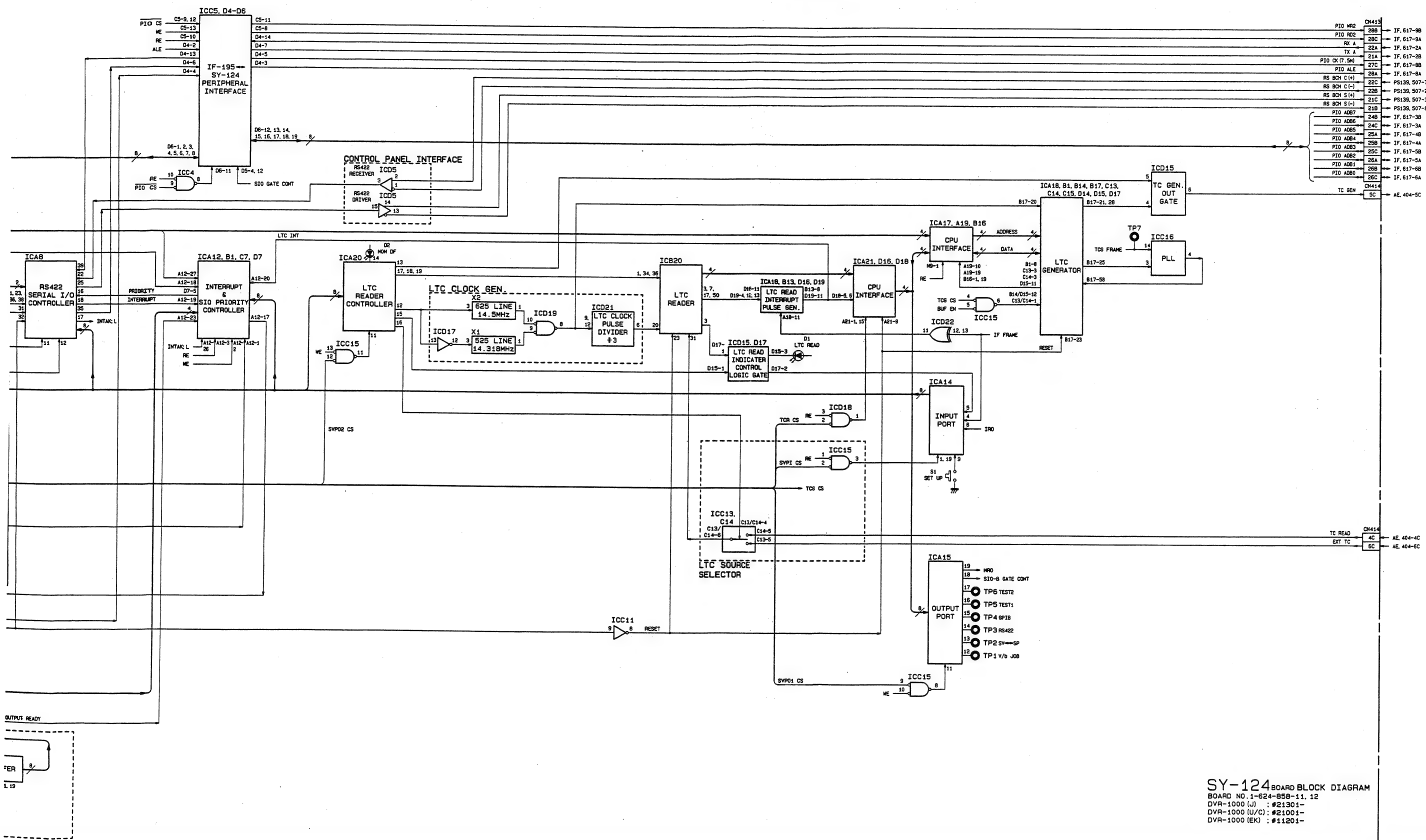

SY-124 BOARD BLOCK DIAGRAM
 BOARD NO. 1-624-858-11. 12
 DVR-1000 (J) : #21301-
 DVR-1000 (U/C) : #21001-
 DVR-1000 (EK) : #11201-

IF-134, IF-135, IF-138 INTERFACE BLOCK DIAGRAM

INTERFACE

- IF-134 BOARD : RS-422 Interface Board
- IF-135 BOARD : GP-IB Interface Board
- IF-138 BOARD : Interface Mother Board

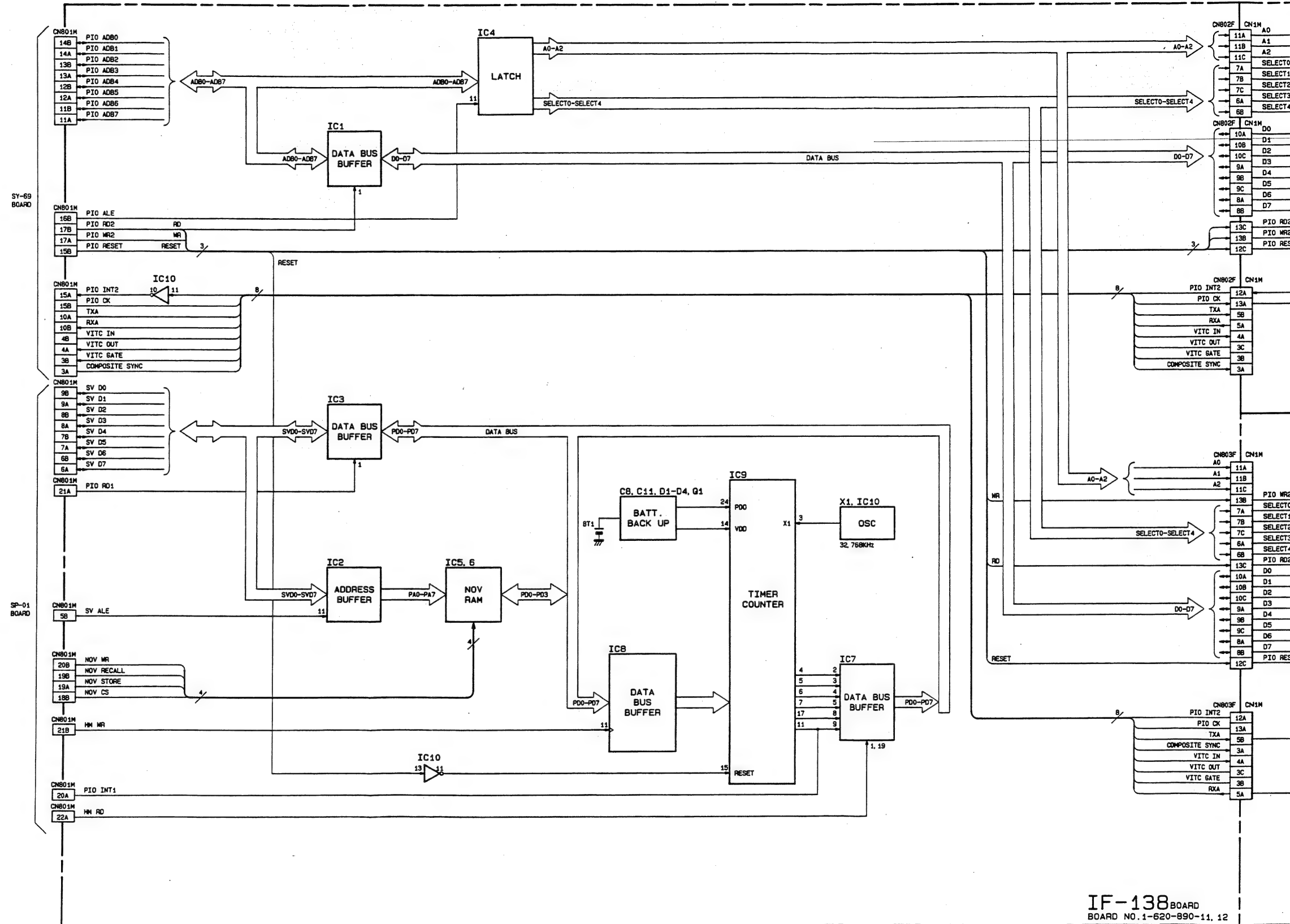

IF-138 BOARD
BOARD NO. 1-620-890-11, 12

IF-134, IF-135, IF-138
BLOCK DIAGRAM INTERFACE

INTERFACE IF-134, IF-135, IF-138
BLOCK DIAGRAM

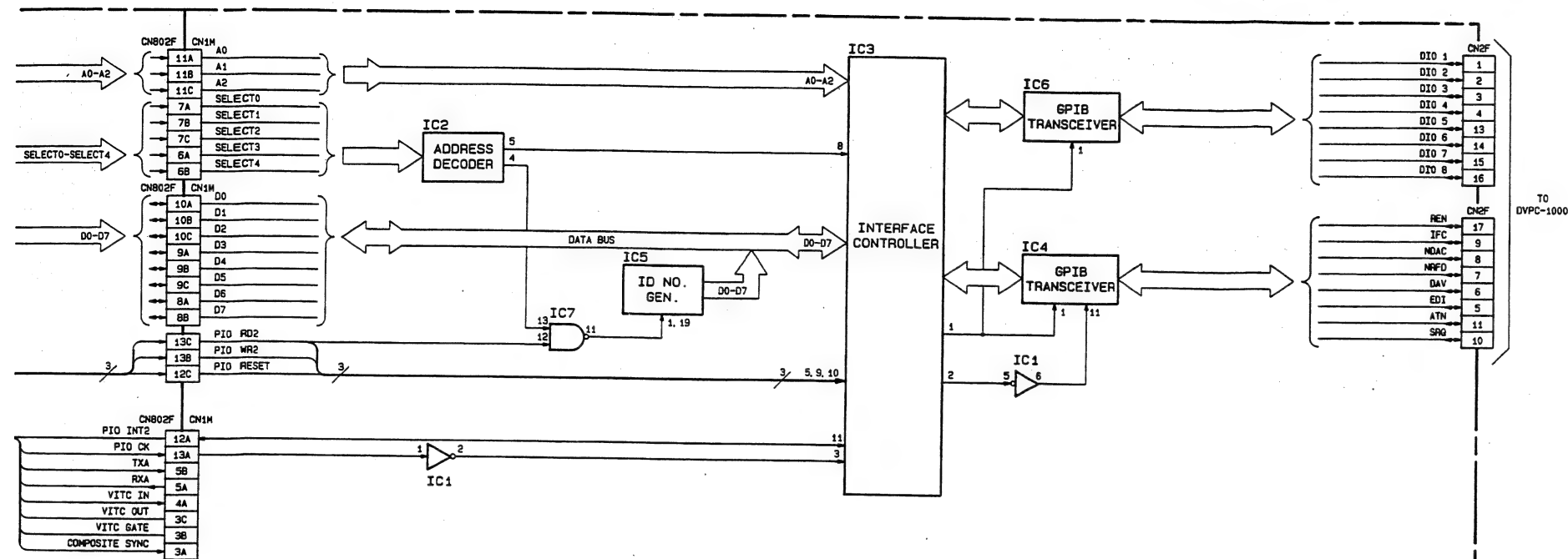

IF-135 BOARD (GPiB INTERFACE)
BOARD NO. 1-620-889-11, 12

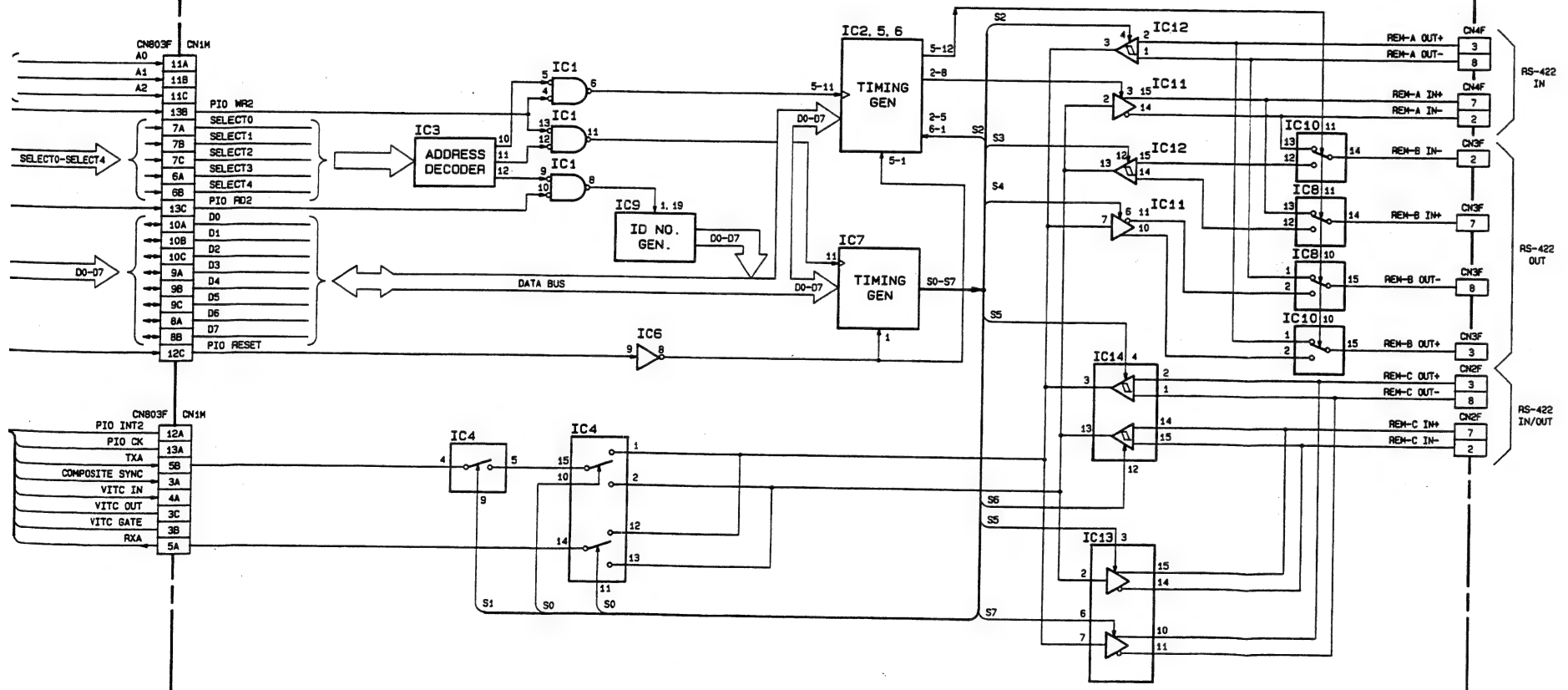

IF-134 BOARD (RS-422 INTERFACE)
BOARD NO. 1-620-888-12, 13

138 BOARD
NO. 1-620-890-11, 12

INTERFACE (RS-422/GPiB)
DVR-1000 (J) : #21301-
DVR-1000 (U/C) : #21001-
DVR-1000 (EK) : #11201-

INTERFACE

IF-210 BOARD : RS-232C Interface Board

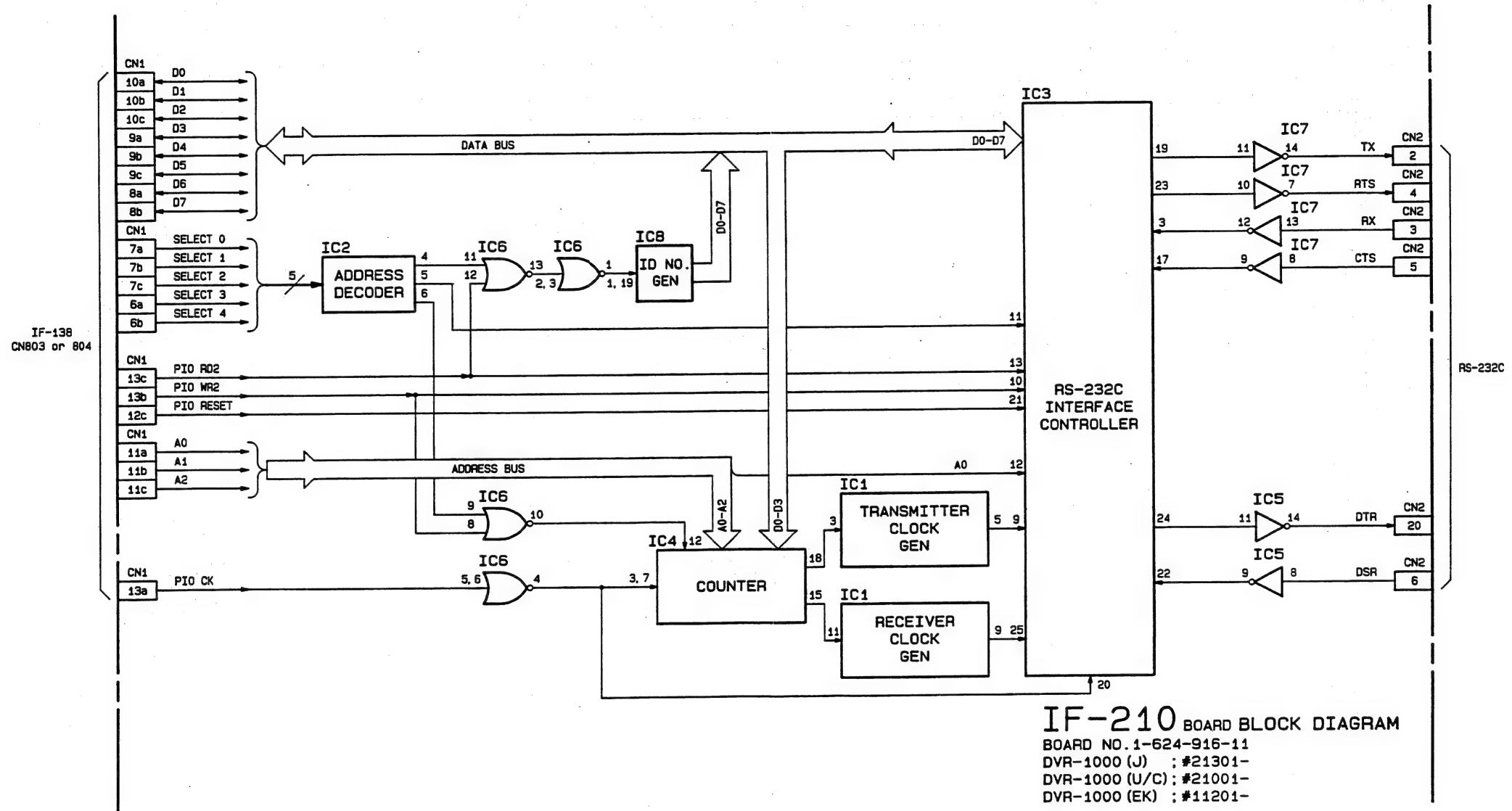

INTERFACE

IF-221 BOARD ; Parallel I/O Interface Board

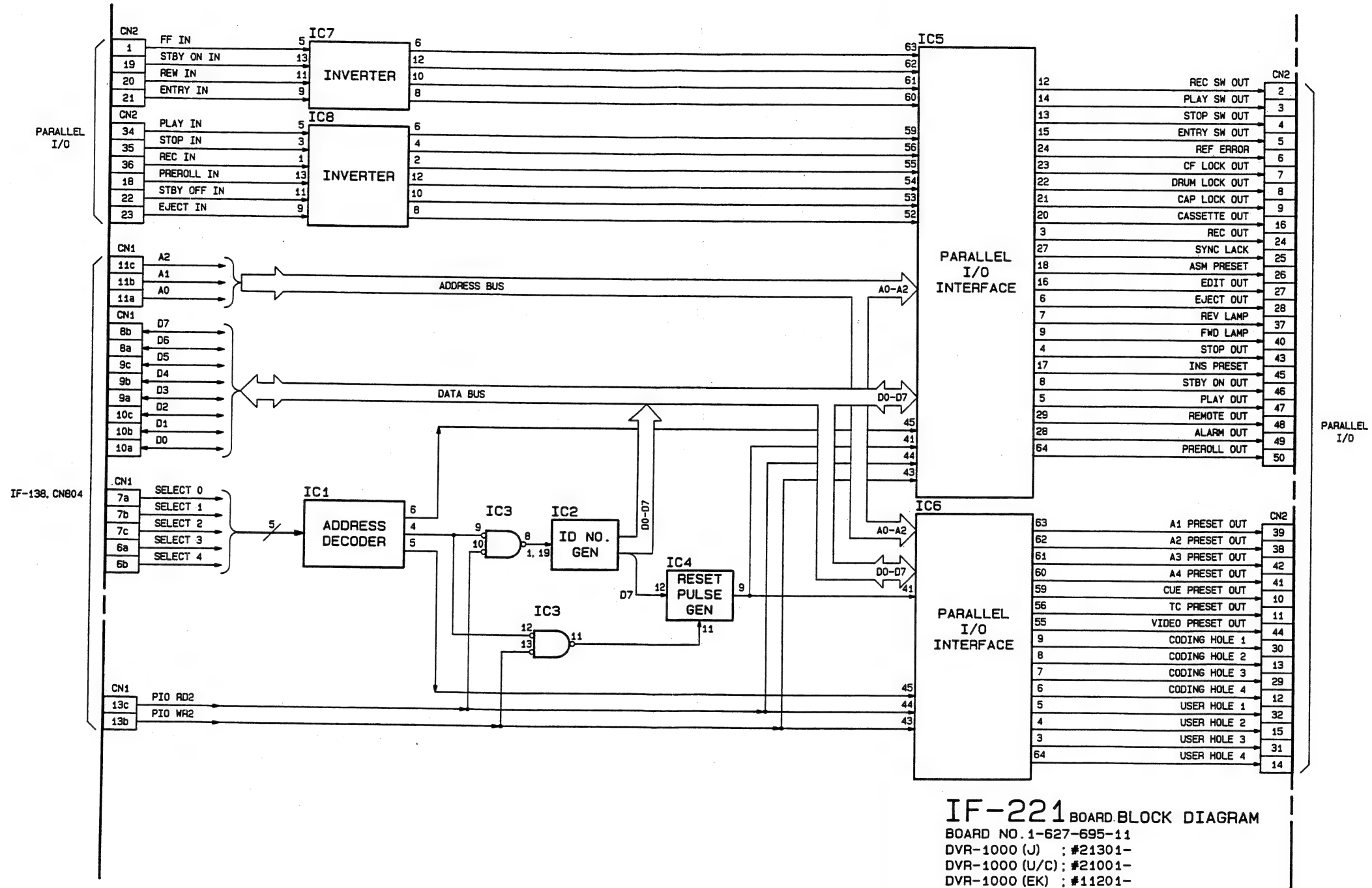

FUNCTION CONTROL PANEL

- CP-106 BOARD :Function Control Panel
- DET-3 BOARD :Search Dial Detector
- PS-139 BOARD :Power Supply Relaying
- RE-44 BOARD :Rotary Encoder Detector
- SW-157 BOARD :Switch
- SW-158 BOARD :Switch

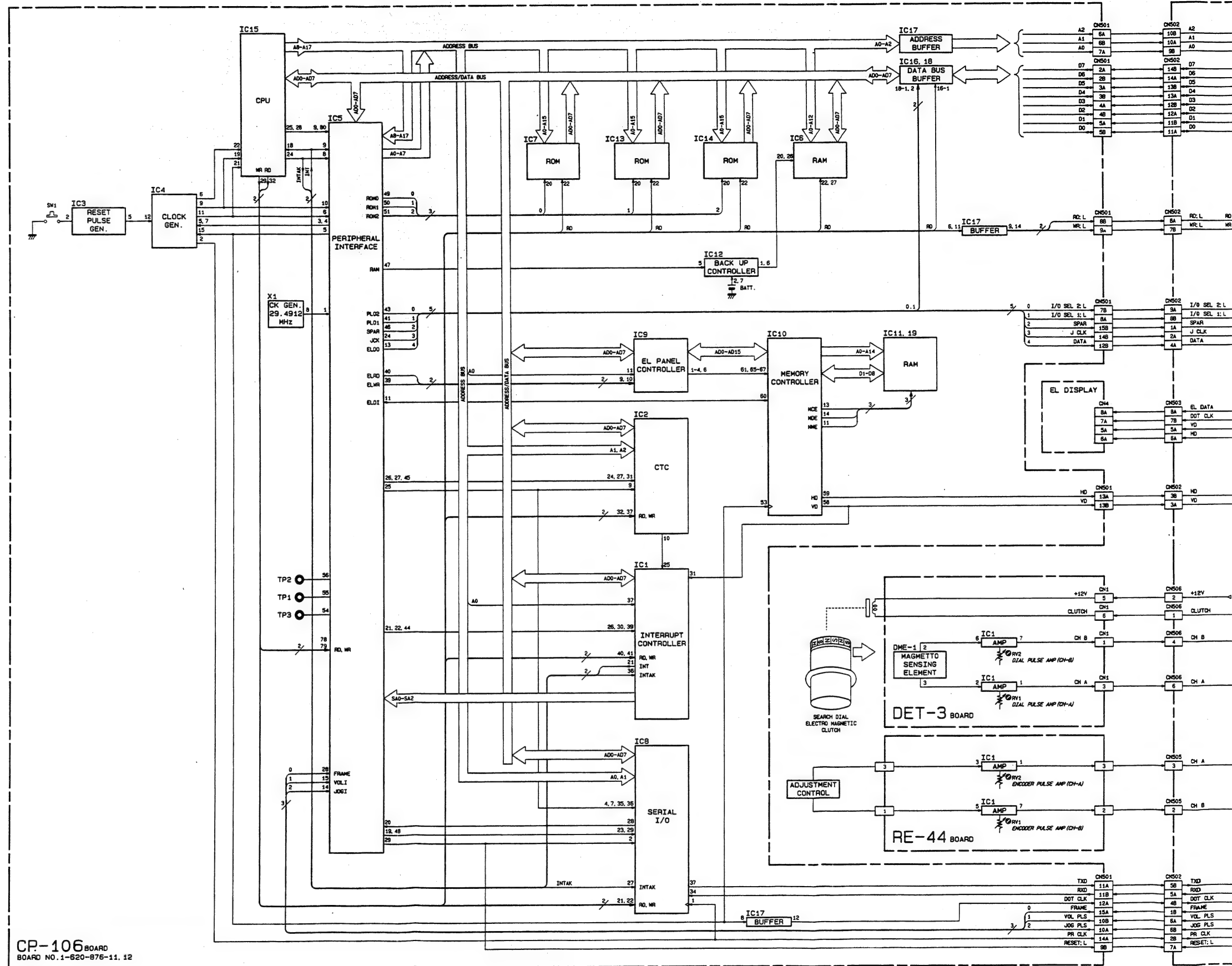

CP-106 BOARD
BOARD NO. 1-620-876-11. 12

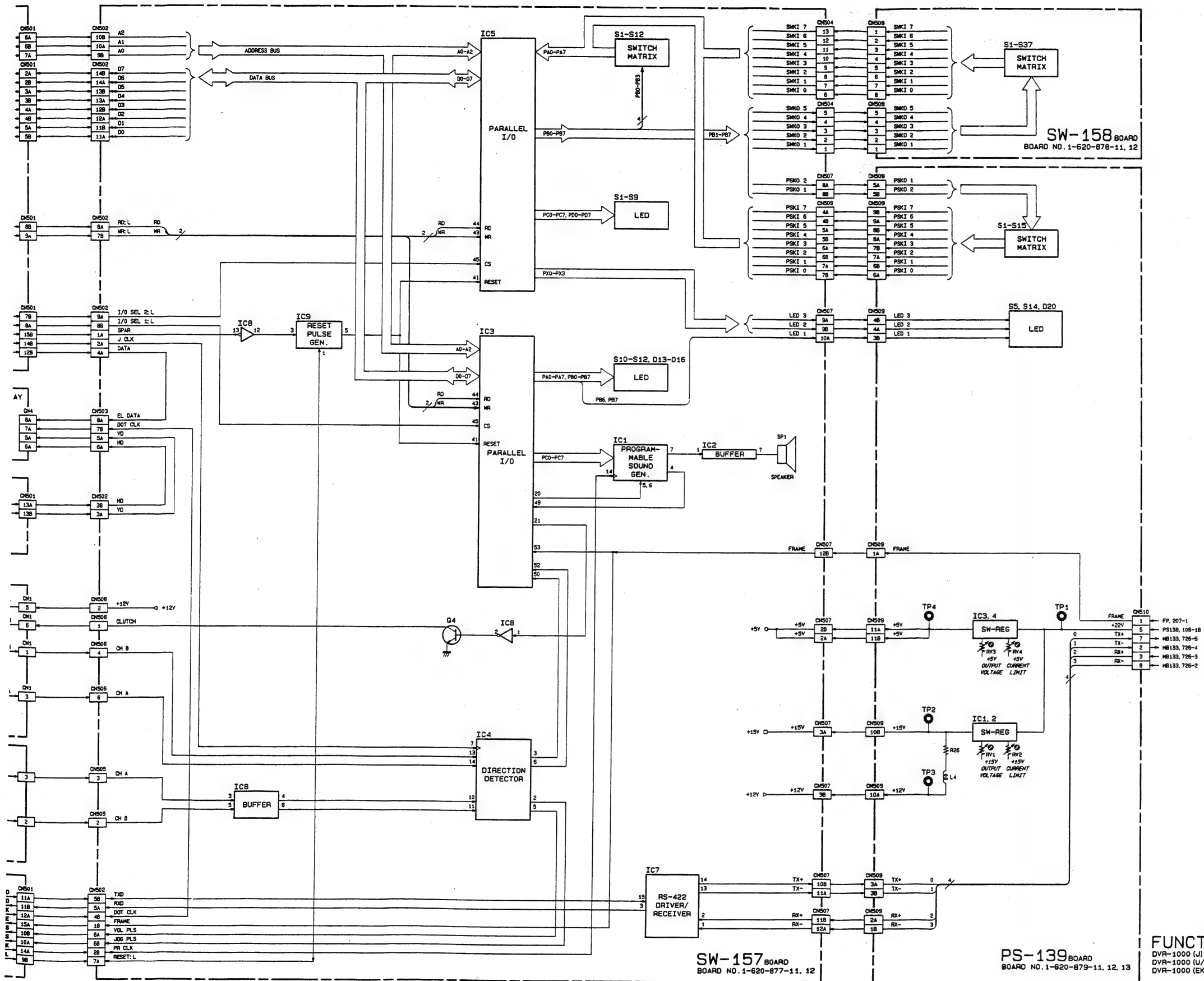

FUNCTION CONTROL PANEL BLOCK DIAGRAM
DVR-1000 (J) : #10001-
DVR-1000 (U/C) : #10001-
DVR-1000 (EK) : #10001-

MD-43 BOARD
Motor Driver

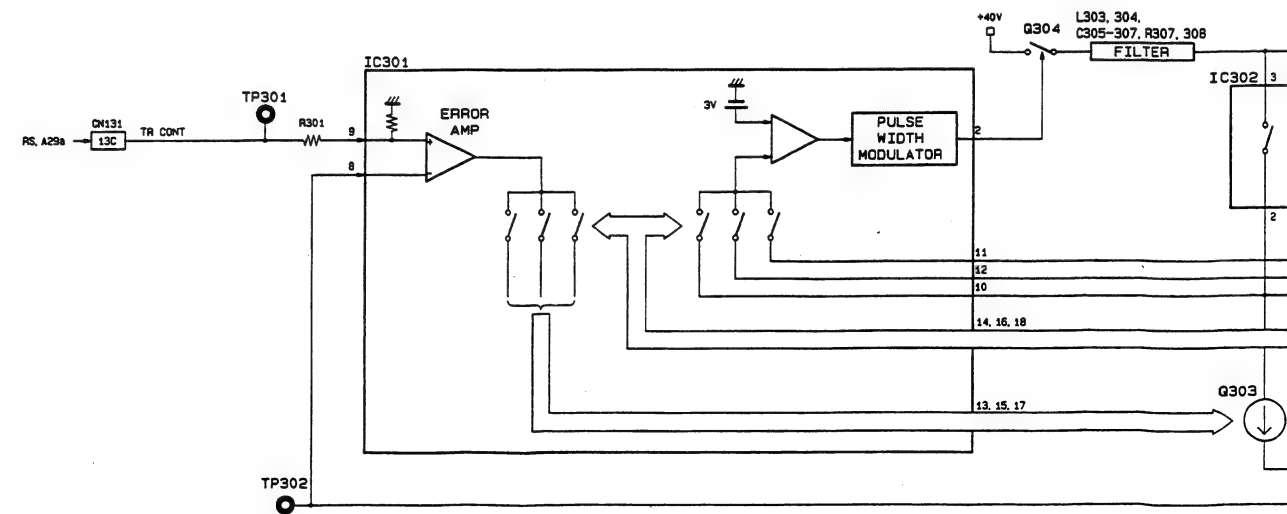
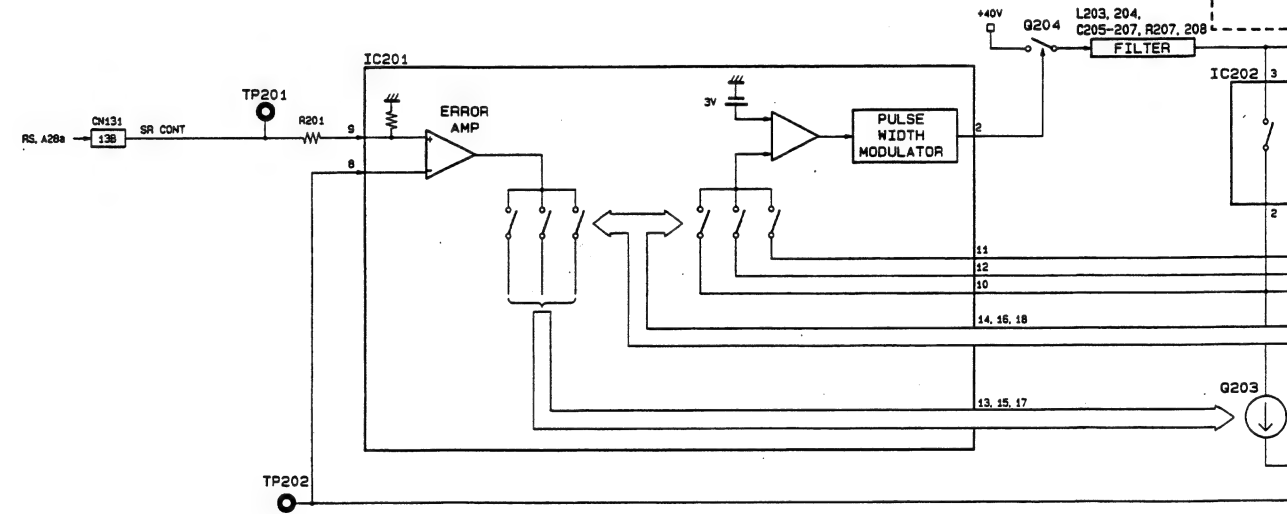
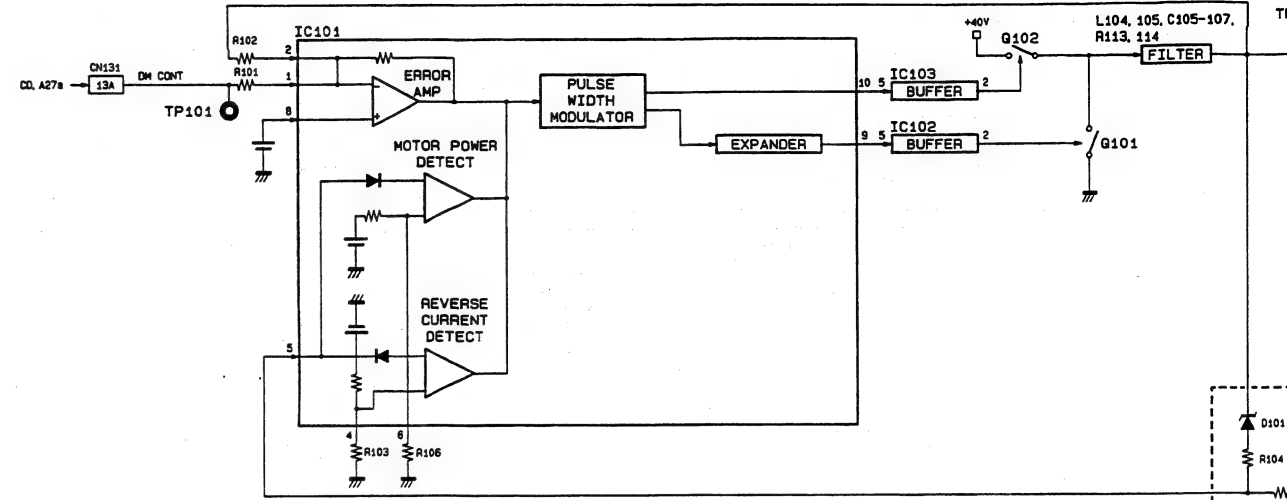

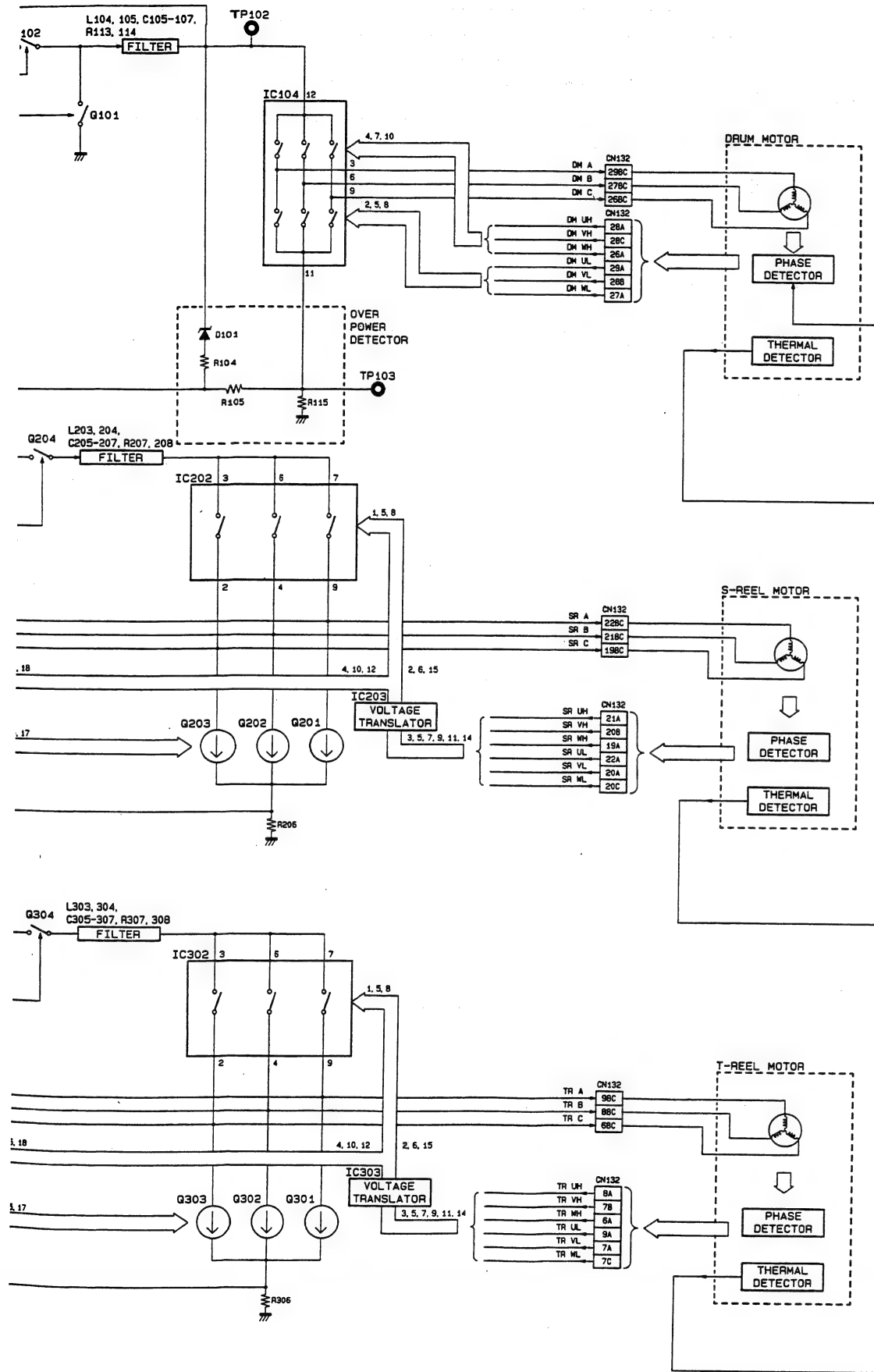

A-41

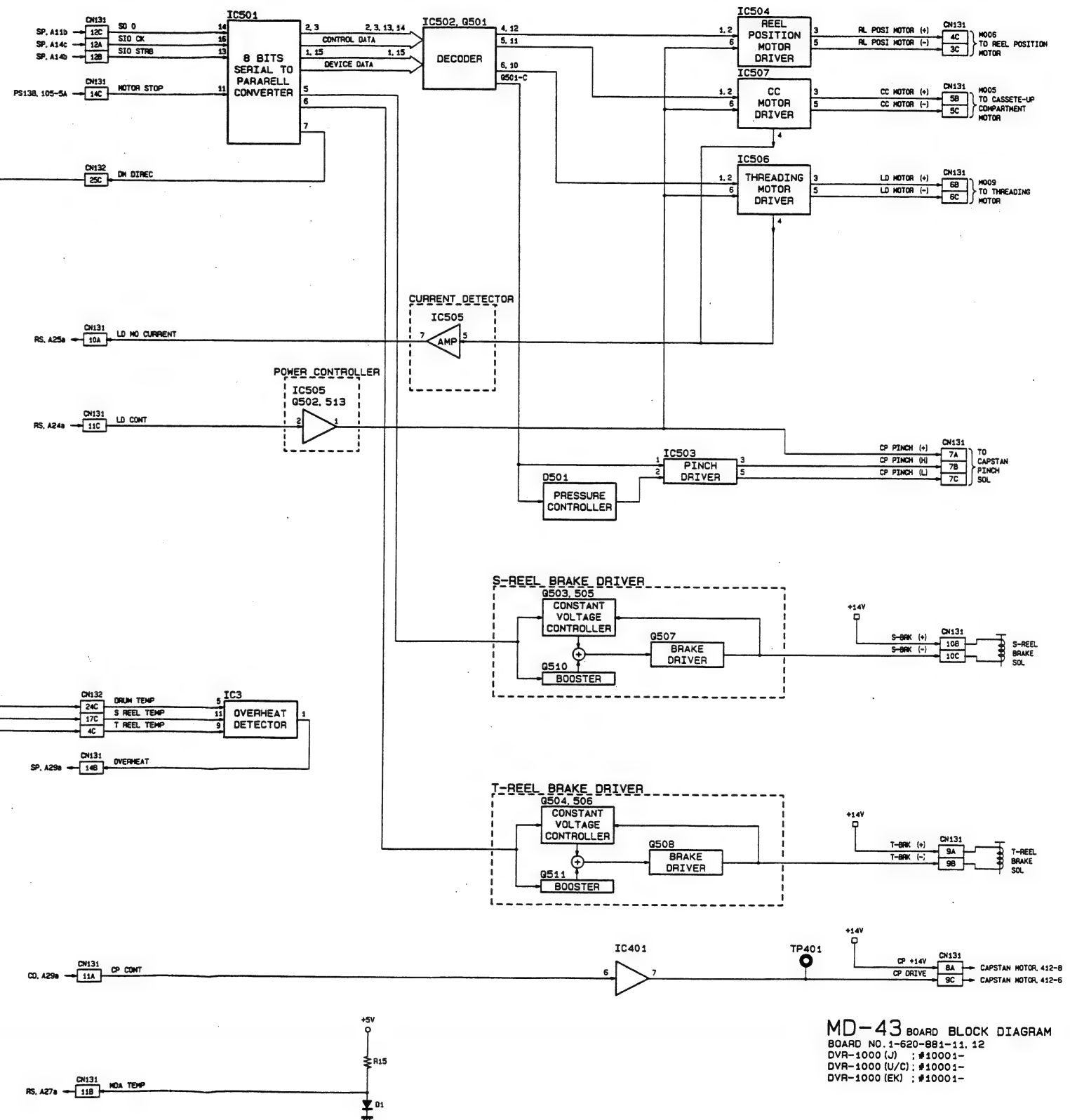

A-42

MD-43 BOARD BLOCK DIAGRAM
 BOARD NO. 1-620-881-11, 12
 DVR-1000 (J) ; #10001-
 DVR-1000 (U/C) ; #10001-
 DVR-1000 (EX) ; #10001-

POWER SUPPLY

CT-74 BOARD : Regulator Controller
PS-138 BOARD : Power Supply
RE-32 BOARD : Switching Regulator

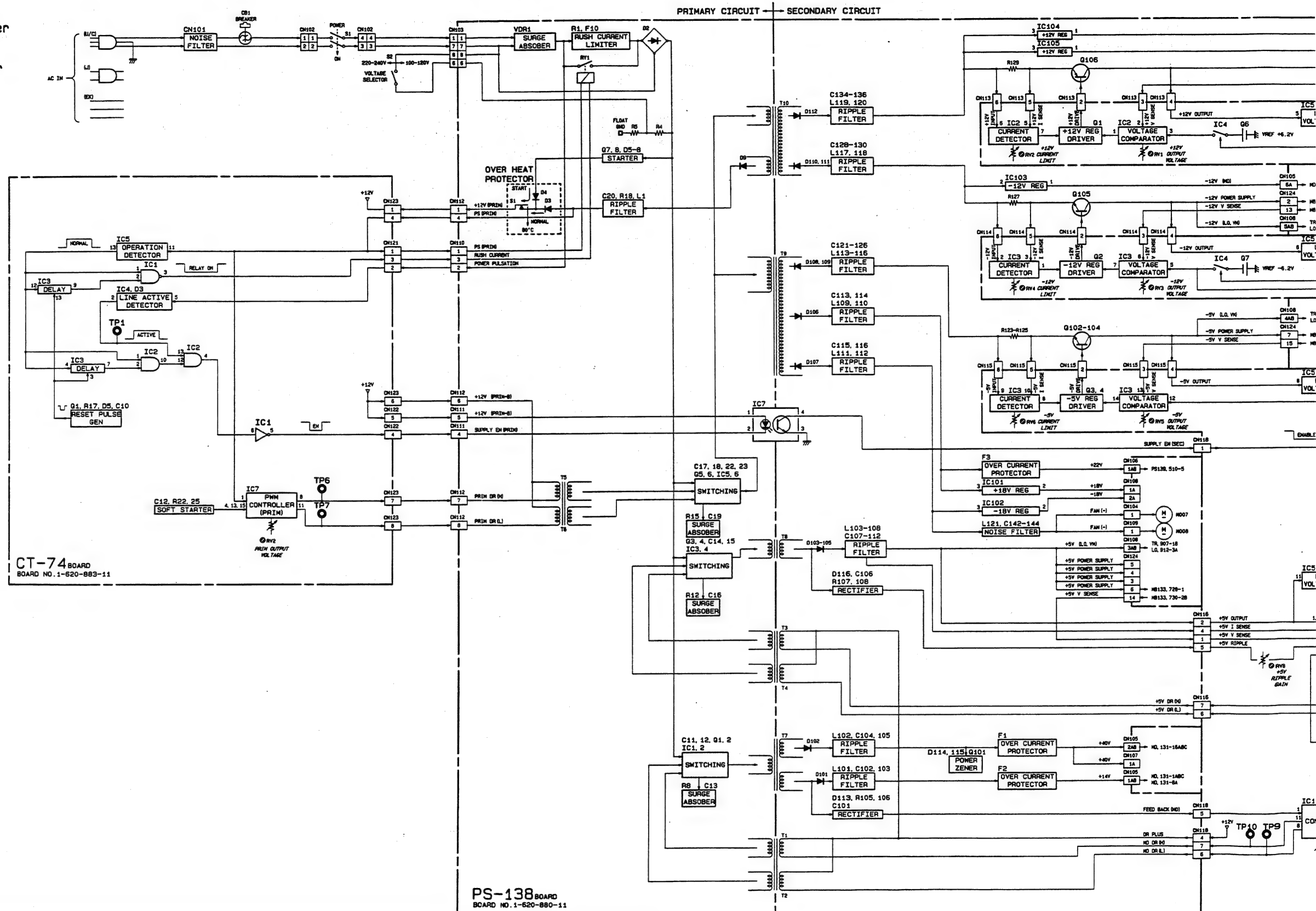

CT-74 BOARD
BOARD NO. 1-620-883-11

PS-138 BOARD
BOARD NO. 1-620-880-11

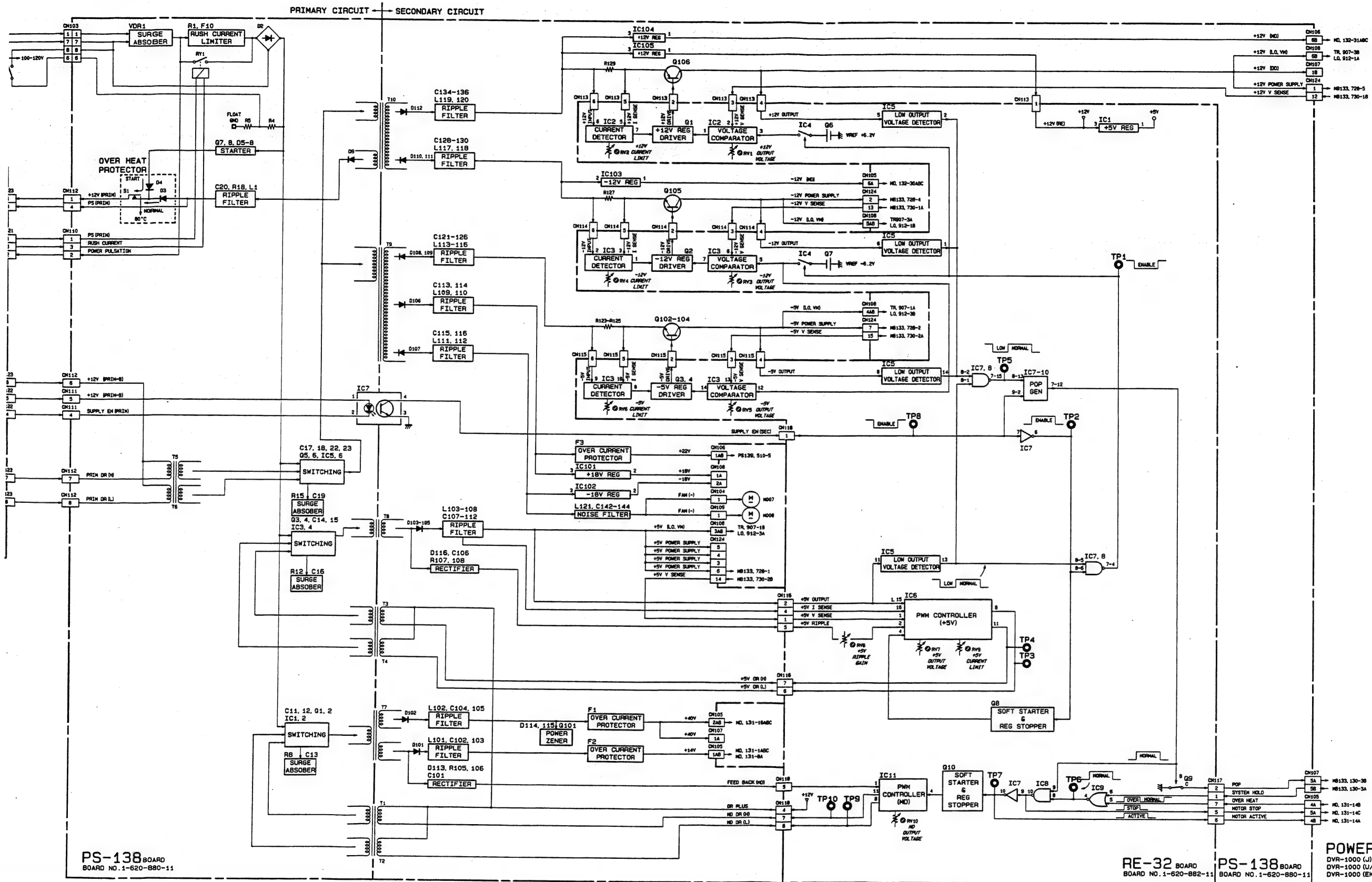

PS-138 BOARD
BOARD NO. 1-620-880-11

RE-32 BOARD
BOARD NO. 1-620-882-11

PS-138 BOARD
BOARD NO. 1-620-880-11

POWER SUPPLY BLOCK DIAGRAM
DVR-1000 (J) : #10001-
DVR-1000 (U/O) : #10001-
DVR-1000 (EK) : #10001-

SECTION B

SCHEMATIC DIAGRAMS & BOARD LAYOUTS

INDEX

| Board Name | Function | Page |
|-----------------|--|------------|
| A AE-05 Board: | Audio (CUE/CTL) & Erase..... | B-10 |
| AH-13 Board: | R/P Head..... | B-123 |
| AH-15 Board: | Full Erase Head..... | B-123 |
| B BP-10 Board: | Relaying..... | B-123 |
| C CC-29 Board: | Cassette Controller (MOVE)..... | B-115 |
| CD-35 Board: | Capstan & Drum Servo..... | B-24 |
| CN-157 Board: | Reel Motor Relaying..... | B-123 |
| CN-191 Board: | BNC Panel..... | B-123 |
| CP-106 Board: | Function Control Panel..... | B-83 |
| CS-21 Board: | Cassette Controller (FIX)..... | B-115 |
| CS-27 Board: | Auto Tracking..... | B-31 |
| CT-74 Board: | Regulator Controller..... | B-99 |
| D DE-17 Board: | Tension Sensor..... | B-123 |
| DET-3 Board: | Search Dial Detector..... | B-83 |
| F FC-37 Board: | Power Supply Relaying..... | B-123 |
| FP-24 Board: | Control Panel Relaying..... | B-123 |
| I IF-134 Board: | RS-422 Interface Board..... | B-77 |
| IF-135 Board: | GP-IB Interface Board (CN-B)..... | B-77 |
| IF-138 Board: | Interface Mother Board..... | B-77 |
| IF-210 Board: | RS-232C Interface Board..... | B-79 (2/3) |
| IF-221 Board: | PARALLEL I/O Interface Board..... | B-79 (3/3) |
| L LE-52 Board: | Coding Hole Sensor (LED)..... | B-115 |
| LE-56 Board: | Indicator (LOAD & RUN)..... | B-115 |
| LO-05 Board: | Audio Line Out..... | B-62 |
| M MB-133 Board: | Mother Board..... | B-107 |
| MB-137 Board: | Motor Drive Mother Board..... | B-123 |
| MD-43 Board: | Motor Driver..... | B-91 |
| P PC-34 Board: | Sensor, User Hole & Reel Position..... | B-115 |
| PC-36 Board: | Tape End/Beginning Sensor..... | B-123 |
| PC-37 Board: | Sensor, Cassette In/Up/Down..... | B-115 |
| PD-36 Board: | Power Rotary Trans Driver..... | B-91 |
| PE-18 Board: | Power Indicator..... | B-115 |
| PR-87 Board: | Processor Interface (CN-A)..... | B-73 |
| PS-138 Board: | Power Supply..... | B-99 |
| PS-139 Board: | Power Supply Relaying..... | B-83 |
| R RE-32 Board: | Switching Regulator..... | B-99 |
| RE-44 Board: | Rotary Encoder Detector..... | B-83 |
| RF-15 Board: | RF..... | B-4 |
| RS-23 Board: | Reel Servo..... | B-31 |
| S SE-47 Board: | Sensor Relaying..... | B-115 |
| SP-01 Board: | Servo Processor..... | B-39 |
| SW-157 Board: | Switch..... | B-83 |
| SW-158 Board: | Switch..... | B-83 |
| SW-179 Board: | Eject Switch..... | B-115 |
| SY-124 Board: | System Controller..... | B-47 |
| T TR-40 Board: | Input Transformer..... | B-68 |
| TR-41 Board: | Coding Hole Sensor (PTR)..... | B-115 |
| V VR-50 Board: | Volume..... | B-123 |

RF-15 BOARD (1-620-901-13)
Component Side

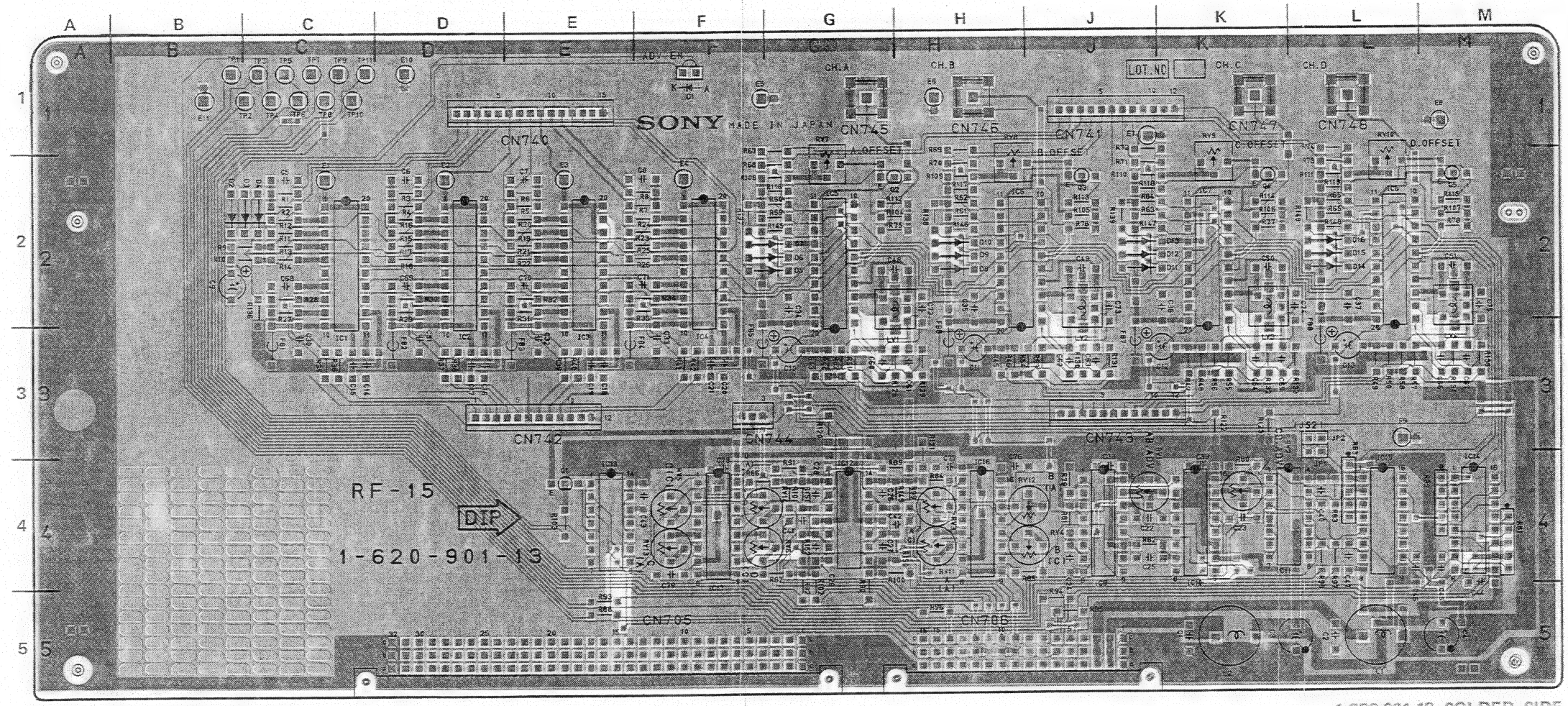

1-620-901-13 COMPONENT SIDE

1-620-901-13 SOLDER SIDE

RF-15 BOARD CARD RACK

RF-15 (1-620-901-13)

DVR-1000

| | | | |
|--------|----|------|-----|
| CN705M | P5 | IC6 | C9 |
| CN706M | H5 | IC7 | C11 |
| CN740M | E1 | IC8 | C13 |
| CN741M | J1 | IC9 | E10 |
| CN742M | E3 | IC10 | E11 |
| CN743M | J3 | IC11 | E12 |
| CN744M | F3 | IC12 | E8 |
| CN745M | G1 | IC13 | E6 |
| CN746M | H1 | IC14 | E14 |
| CN747M | K1 | IC15 | E13 |
| CN748M | L1 | IC16 | H4 |
| | | IC17 | F4 |
| D1 | F1 | | |
| D2 | B2 | JP1 | E12 |
| D3 | C2 | JP2 | E12 |
| D4 | C2 | | |
| D5 | G2 | Q1 | E5 |
| D6 | G2 | Q2 | B8 |
| D7 | G2 | Q3 | B9 |
| D8 | H2 | Q4 | B11 |
| D9 | H2 | Q5 | B14 |
| D10 | H2 | | |
| D11 | J2 | RB1 | E14 |
| D12 | J2 | RB2 | E14 |
| D13 | J2 | RB3 | E12 |
| D14 | L2 | | |
| D15 | L2 | RV1 | E10 |
| D16 | L2 | RV2 | E11 |
| | | RV3 | E9 |
| E1 | C2 | RV4 | E9 |
| E2 | D2 | RV5 | E7 |
| E3 | E2 | RV6 | E7 |
| E4 | F2 | RV7 | B7 |
| E5 | F1 | RV8 | B9 |
| E6 | H1 | RV9 | B11 |
| E7 | J1 | RV10 | B13 |
| E8 | H1 | RV11 | H4 |
| E9 | L3 | RV12 | H4 |
| E10 | D1 | RV13 | F4 |
| E11 | B1 | RV14 | F4 |
| FB1 | C3 | TP1 | A1 |
| FB2 | D3 | TP2 | A1 |
| FB3 | E3 | TP3 | A1 |
| FB4 | E3 | TP4 | A2 |
| FB5 | F3 | TP5 | A2 |
| FB6 | H3 | TP6 | A2 |
| FB7 | J3 | TP7 | A2 |
| FB8 | L3 | TP8 | A2 |
| | | TP9 | A2 |
| IC1 | C2 | TP10 | A2 |
| IC2 | D2 | TP11 | A2 |
| IC3 | E2 | | |
| IC4 | F2 | | |
| IC5 | G2 | | |

| Ref. No. | Pin No. | | |
|----------|---------|-----------|-----|
| | +5V | GND | -5V |
| IC 1 | | 1, 6, 20 | 10 |
| IC 2 | | 1, 6, 20 | 10 |
| IC 3 | | 1, 6, 20 | 10 |
| IC 4 | | 1, 6, 20 | 10 |
| IC 5 | | 5, 10, 20 | 20 |
| IC 6 | | 5, 10, 20 | 20 |
| IC 7 | | 5, 10, 20 | 20 |
| IC 8 | | 5, 10, 20 | 20 |
| IC 9 | 16 | 8 | |
| IC 10 | 16 | 8 | |
| IC 11 | 14 | 7 | |
| IC 12 | 4 | | 11 |
| IC 13 | 14 | 7 | |
| IC 14 | 9 | 16 | 8 |
| IC 15 | 9 | 16 | 8 |
| IC 16 | 16 | 8 | 7 |
| IC 17 | 16 | 8 | 7 |

RF-15 BOARD
RF

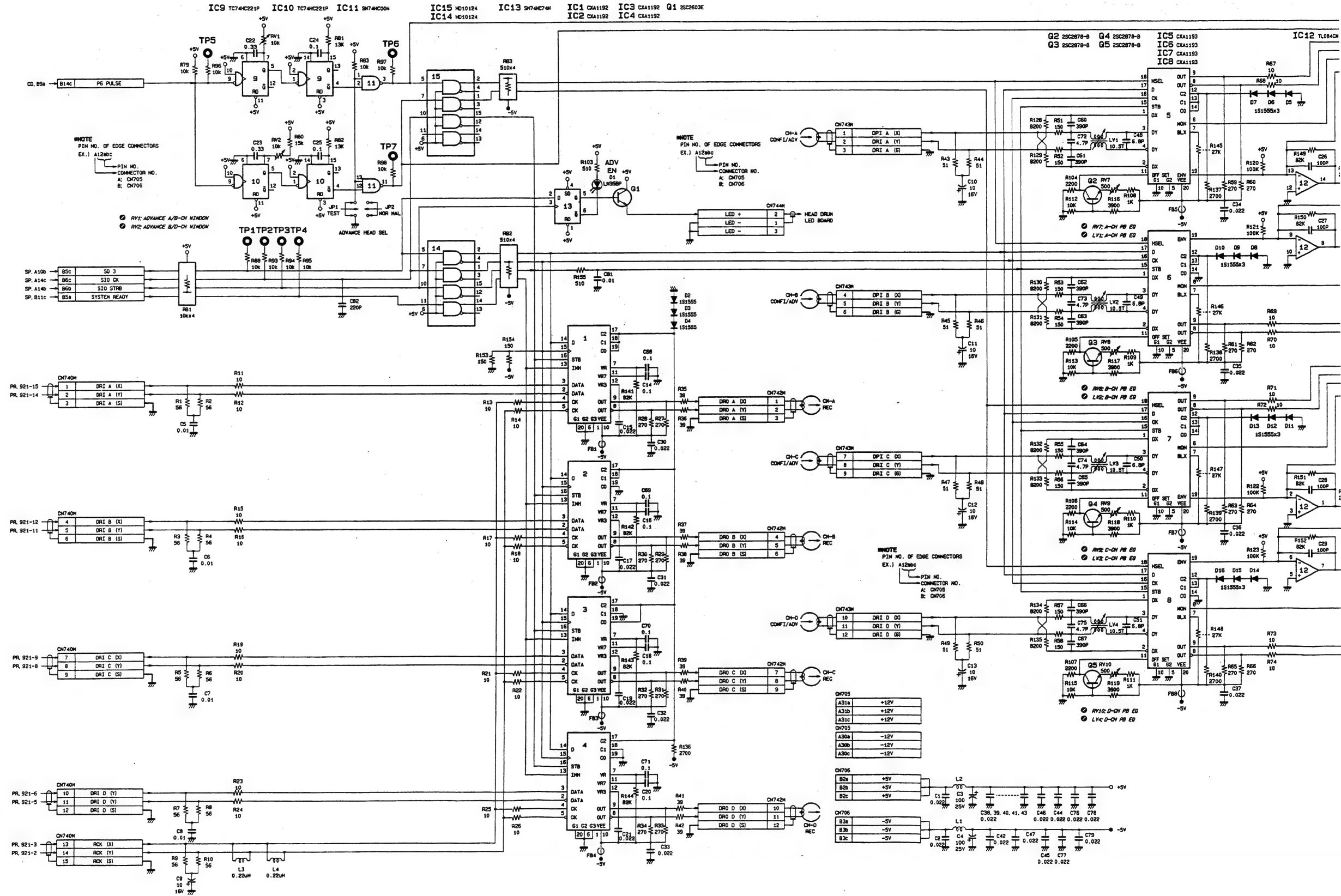

AE-05 BOARD (1-620-891-12)
Component Side

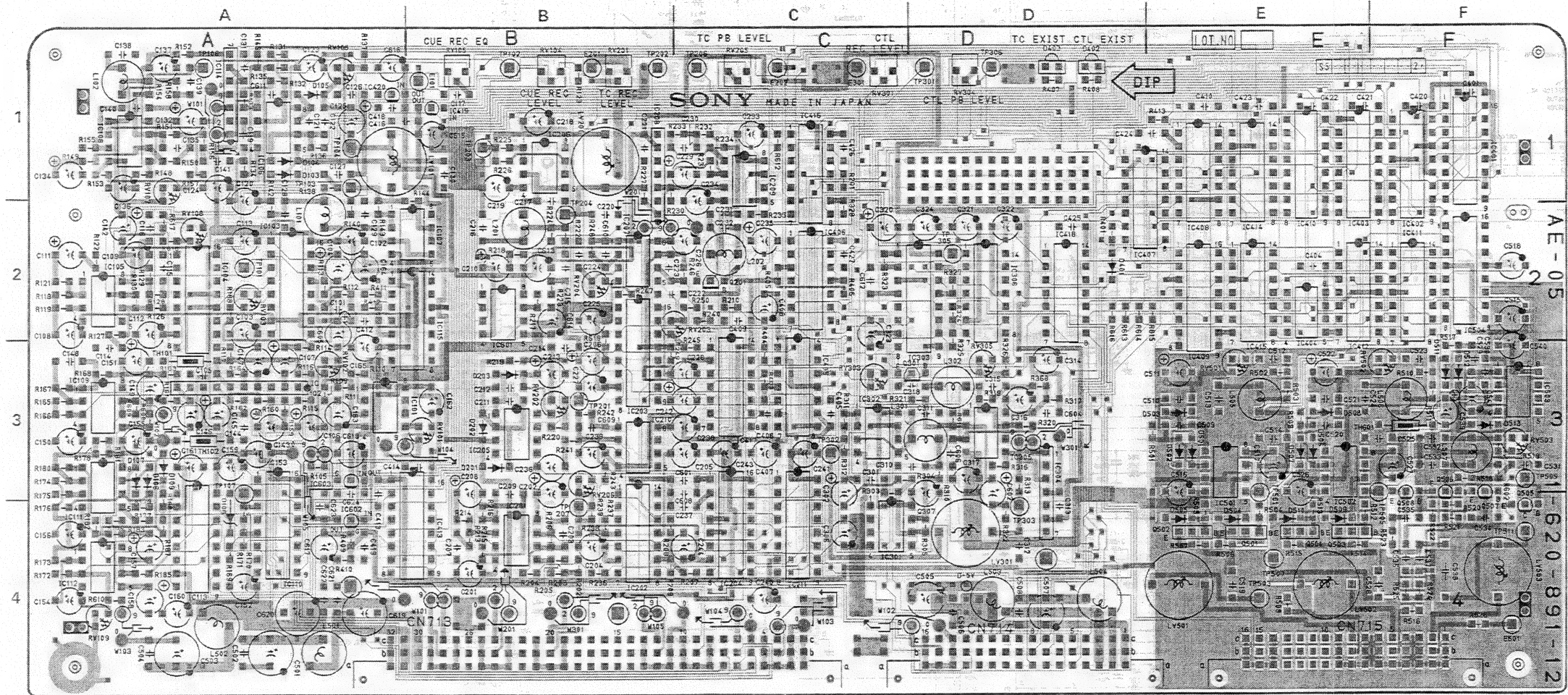

1-620-891-12 COMPONENT SIDE

1-620-891-12 SOLDER SIDE

AE-05 BOARD CARD RACK

AE-05 (1-620-891-12)

DWR-1000

| | | |
|-----------|----------|----------|
| CN713M B4 | IC204 C4 | Q505 F4 |
| CN714M D4 | IC205 B3 | Q506 F4 |
| CN715M E4 | IC206 B1 | Q507 F4 |
| | IC207 B2 | Q508 F4 |
| D103 A1 | IC208 B1 | |
| D104 A1 | IC209 C1 | RV101 B3 |
| D105 A1 | IC210 B3 | RV102 A3 |
| D106 A3 | IC211 C4 | RV103 A2 |
| D107 A3 | IC301 C4 | RV104 B1 |
| D108 A4 | IC302 C3 | RV105 B1 |
| D109 A3 | IC303 D2 | RV106 A1 |
| D201 B3 | IC304 D3 | RV107 A1 |
| D202 B3 | IC305 D3 | RV108 A2 |
| D203 B3 | IC306 D2 | RV109 A4 |
| D401 D2 | IC401 F1 | RV201 B1 |
| D402 D1 | IC402 F1 | RV202 B3 |
| D403 D1 | IC403 E1 | RV203 C2 |
| D501 E3 | IC404 E2 | RV204 B2 |
| D502 E3 | IC405 C3 | RV205 C1 |
| D503 E3 | IC406 C2 | RV206 B3 |
| D504 E4 | IC407 D2 | RV301 C1 |
| D505 E4 | IC408 E1 | RV303 C3 |
| D506 E3 | IC409 E2 | RV304 D1 |
| D507 E3 | IC410 E1 | RV305 D3 |
| D508 E3 | IC411 F2 | RV501 E3 |
| D509 E4 | IC412 E2 | RV502 F3 |
| D510 E4 | IC413 B4 | RV503 F3 |
| D511 F3 | IC414 E1 | |
| D512 F3 | IC415 E2 | TE101 A3 |
| D513 F3 | IC416 C1 | TE102 A3 |
| | IC417 C3 | TE601 F3 |
| E101 B1 | IC418 D2 | |
| E201 B1 | IC419 B1 | TP101 A2 |
| E202 C1 | IC420 A1 | TP102 B1 |
| E301 C1 | IC501 E3 | TP104 A1 |
| E501 F4 | IC502 E3 | TP106 A1 |
| | IC503 F3 | TP107 A3 |
| IC101 A3 | IC504 F2 | TP201 B3 |
| IC102 A3 | IC601 B2 | TP202 B1 |
| IC103 A2 | IC602 A4 | TP203 B1 |
| IC104 A2 | IC603 A3 | TP204 B2 |
| IC105 A2 | | TP206 C1 |
| IC106 A1 | LV101 A1 | TP207 B4 |
| IC107 B2 | LV201 B1 | TP301 D1 |
| IC108 A1 | LV301 D4 | TP302 C3 |
| IC109 A3 | LV501 E4 | TP303 D4 |
| IC110 A4 | LV502 E4 | TP305 D2 |
| IC111 A3 | LV503 F4 | TP306 D1 |
| IC112 A4 | | TP501 E3 |
| IC113 A4 | Q201 C2 | TP503 E4 |
| IC114 A1 | Q301 D3 | TP505 F4 |
| IC115 B2 | Q501 E4 | TP507 E4 |
| IC201 B4 | Q502 E4 | TP509 F3 |
| IC202 B4 | Q503 E4 | TP511 F4 |
| IC203 B3 | Q504 E4 | |

AE-05 BOARD (1/2)
Audio (CUE/CTL) & Erase

CARD RACK AE-05 (1/2) BOARD **AE-05 (1/2) BOARD** CARD RACK

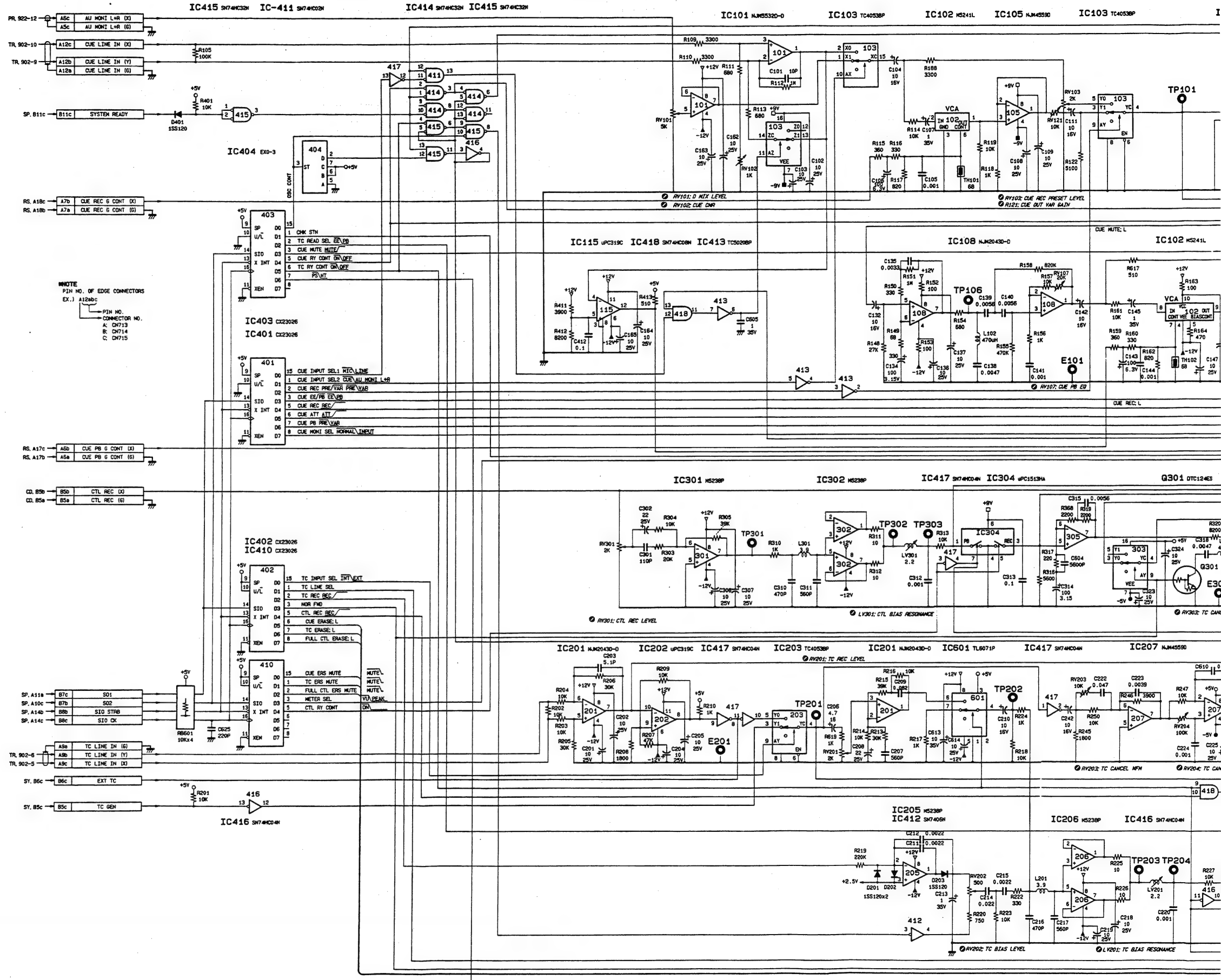

CARD RACK AE-05 (2/2) BOARD AE-05 (2/2) BOARD CARD RACK

AE-05 BOARD (2/2)
Audio (CUE/CTL) & Erase

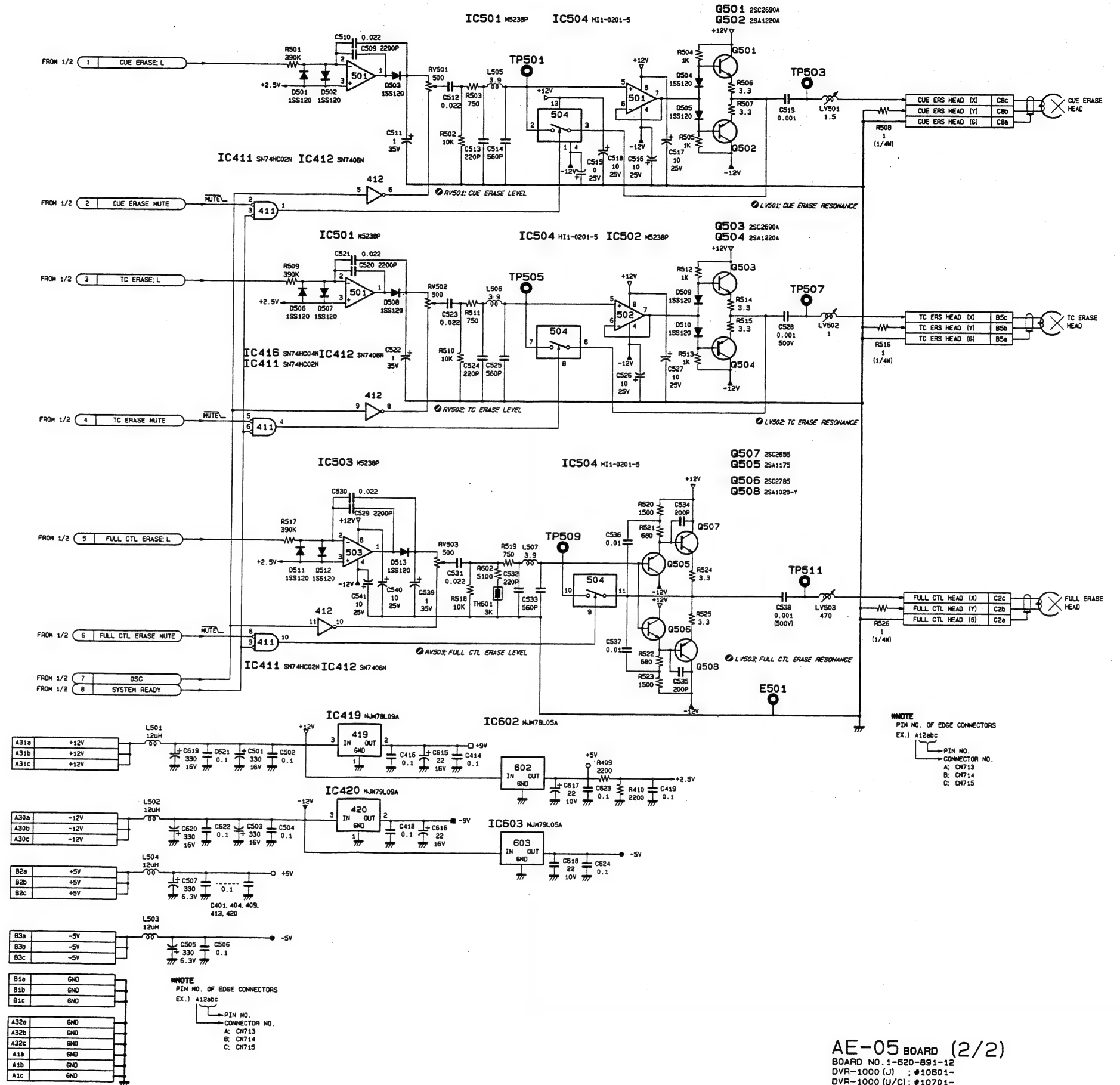

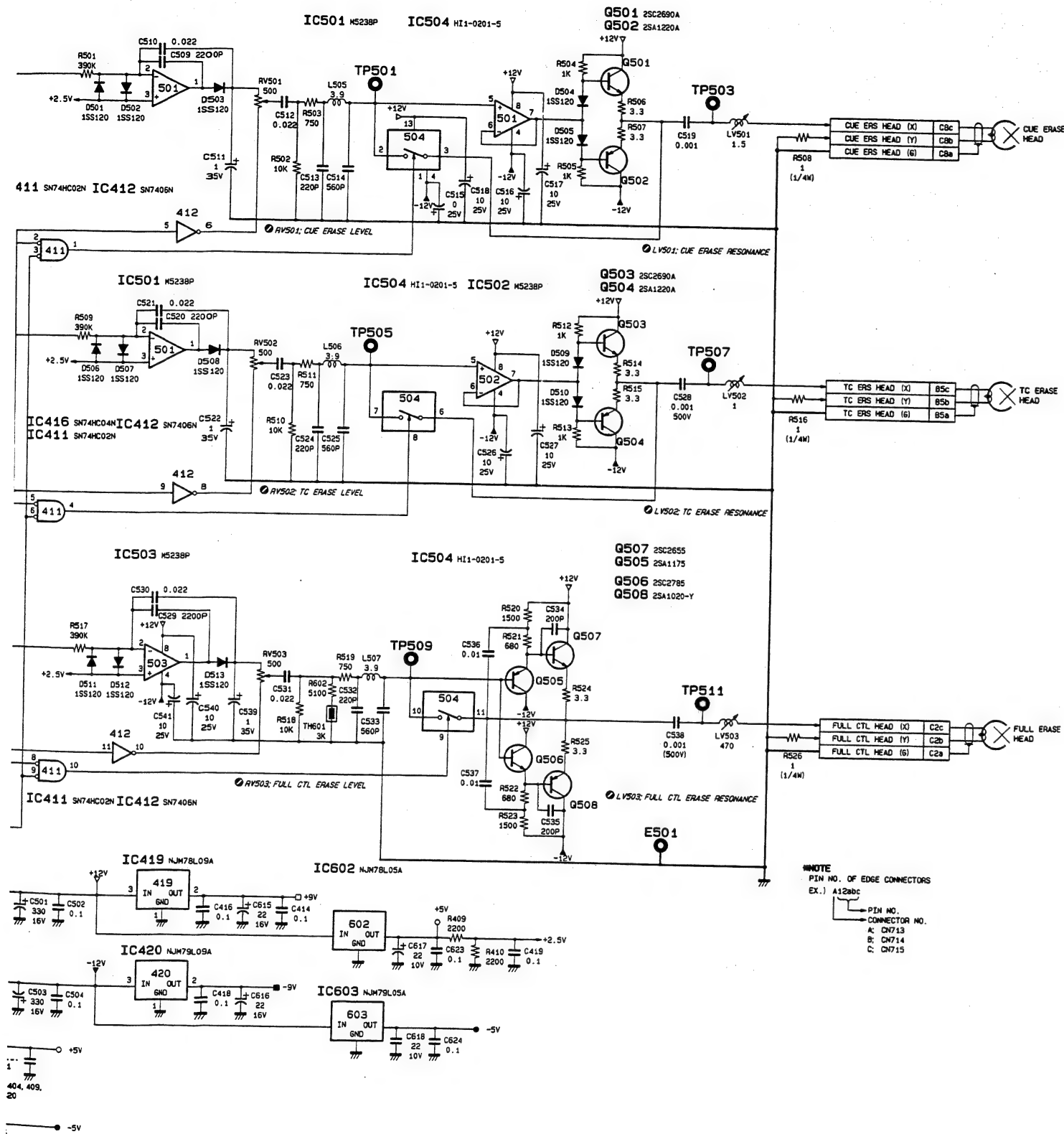

NOTE
PIN NO. OF EDGE CONNECTORS
EX.) A12abc
PIN NO.
CONNECTOR NO.
A: CN713
B: CN714
C: CN715

IN NO.
CONNECTOR NO.
: CN713
: CN714
: CN715

AE-05 BOARD (2/2)
BOARD NO. 1-620-891-12
DVR-1000 (J) : #10601-
DVR-1000 (U/C) : #10701-
DVR-1000 (EK) : #10701-

CD-35 BOARD (1-620-884-12)
Component Side

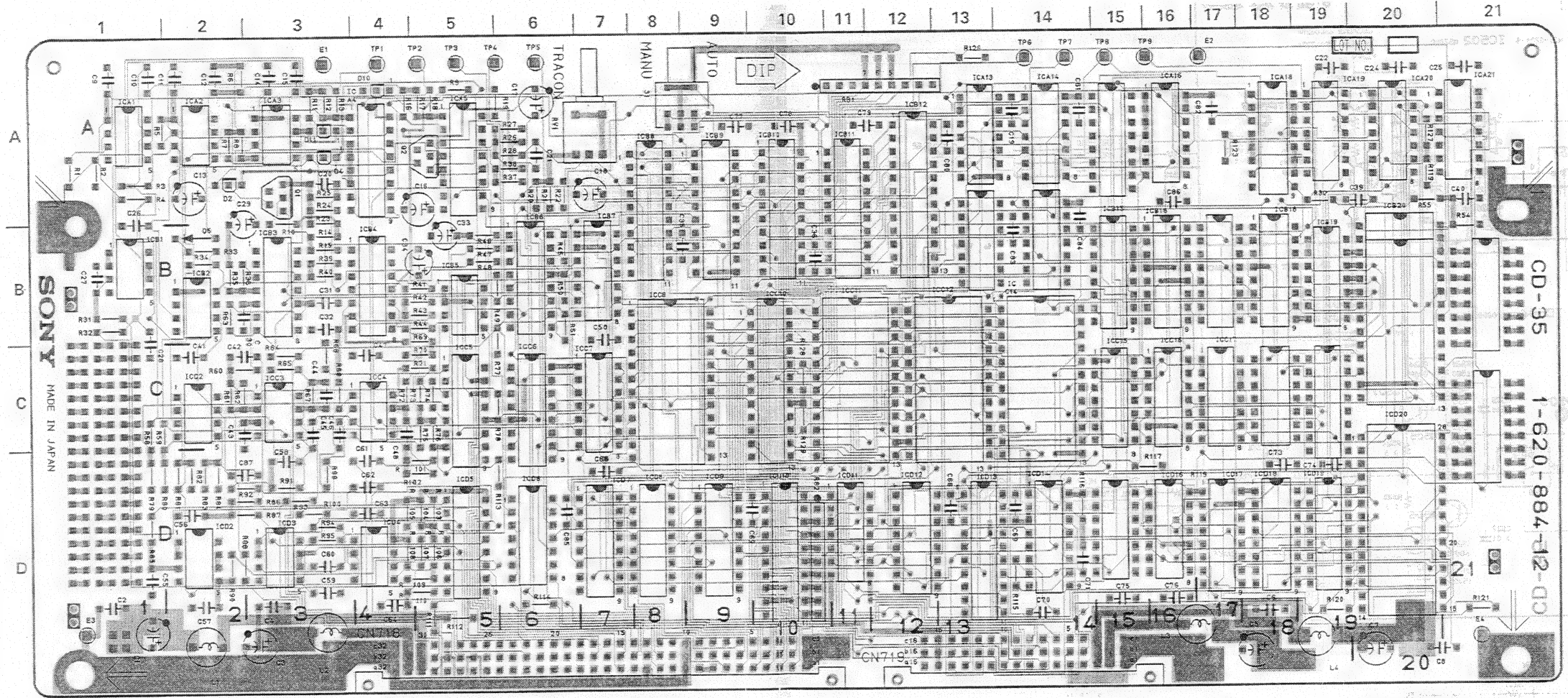

1-620-884-12 COMPONENT SIDE

1-620-884-12 SOLDER SIDE

CD-35 BOARD CARD RACK

CD-35 (1-620-884-12)

DVR-1000

CN718M D5
CN719M D14

D2 A2
D4 A3
D5 B2
D10 A4
D11 A3

E1 A3
E2 A17
E3 D1
E4 D21

Q1 A3
Q2 A5

RB1 A12

RV1 A7

S1 A8

TP1 A4
TP2 A5
TP3 A5
TP4 A6
TP5 A6
TP6 A14
TP7 A14
TP8 A15
TP9 A16

| Ref. No. | Pin No. | | | | |
|----------|---------|-------|------|-----|------|
| | +12V | +5V | GND | -5V | -12V |
| IC A1 | 8 | | | | 4 |
| IC A2 | 8 | | | | 4 |
| IC A3 | 1 | | 7 | | 4 |
| IC A4 | | 16 | 8 | 7 | |
| IC A5 | | 16 | 8 | 7 | |
| IC A13 | | 14 | 7 | | |
| IC A14 | | 14 | 7 | | |
| IC A16 | | 14 | 7 | | |
| IC A18 | | 4 | 3,14 | | |
| IC A19 | | 14 | 7 | | |
| IC A20 | | 14 | 7 | | |
| IC A21 | | 14 | 7 | | |
| IC B1 | 8 | | | | 4 |
| IC B2 | 1 | | 7 | | 4 |
| IC B3 | 11 | | 3,8 | | 6 |
| IC B4 | 11 | | 3,8 | | 6 |
| IC B5 | | 8 | | 4 | |
| IC B6 | | 16 | 8 | | |
| IC B7 | | 14 | 7 | | |
| IC B8 | | 20 | 10 | | |
| IC B9 | | 20 | 10 | | |
| IC B10 | | 20 | 10 | | |
| IC B11 | | 20 | 10 | | |
| IC B12 | | 24 | 12 | | |
| IC B15 | | 16 | 8 | | |
| IC B16 | | 16 | 8 | | |
| IC B18 | | 16 | 8 | | |
| IC B19 | | 14 | 7 | | |
| IC B20 | | 24 | 12 | | |
| IC C1 | 8 | | | | 4 |
| IC C2 | 8 | | | | 4 |
| IC C3 | 8 | | | | 4 |
| IC C4 | 8 | | | | 4 |
| IC C5 | | 16 | 8 | 7 | |
| IC C6 | | 16 | 8 | | |
| IC C7 | | 14 | 7 | | |
| IC C8 | | 24 | 12 | | |
| IC C10 | | 24 | 12 | | |
| IC C11 | | 24 | 12 | | |
| IC C12 | | 24 | 12 | | |
| IC C14 | | 24 | 12 | | |
| IC C15 | | 14 | 7 | | |
| IC C16 | | 14 | 7 | | |
| IC C17 | | 14 | 7 | | |
| IC D2 | 8 | | | | 4 |
| IC D3 | 8 | | | | 4 |
| IC D4 | | 8 | 4 | | |
| IC D5 | | 16 | 8 | 7 | |
| IC D6 | | 14 | 7 | | |
| IC D7 | | 16 | 8 | | |
| IC D8 | | 16 | 8 | | |
| IC D9 | | 16 | 8 | | |
| IC D10 | | 20 | 10 | | |
| IC D11 | | 14 | 7 | | |
| IC D12 | | 16 | 8 | | |
| IC D13 | | 20 | 10 | | |
| IC D14 | | 16 | 8 | | |
| IC D16 | | 14 | 7 | | |
| IC D17 | | 16 | 8 | | |
| IC D18 | | 16 | 8 | | |
| IC D19 | | 16 | 8 | | |
| IC D20 | | 1, 28 | 14 | | |

CD-35 BOARD

Capstan & Drum Servo

CARD RACK CD-35 BOARD CD-35 BOARD CARD RACK

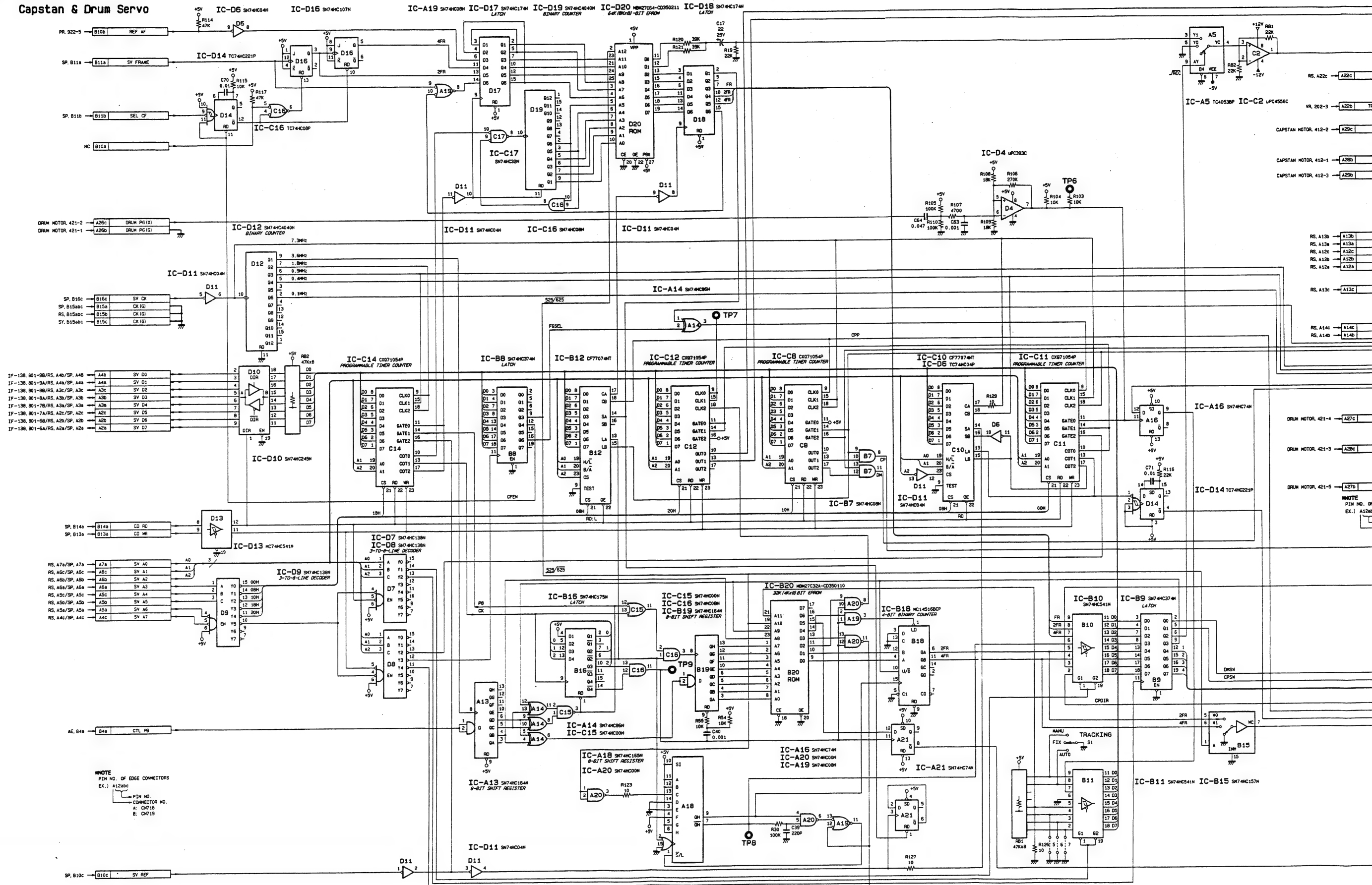

NOTE
PIN NO. OF EDGE CONNECTORS
EX.) A1240C
CONNECTOR NO.
A: CH718
B: CH719

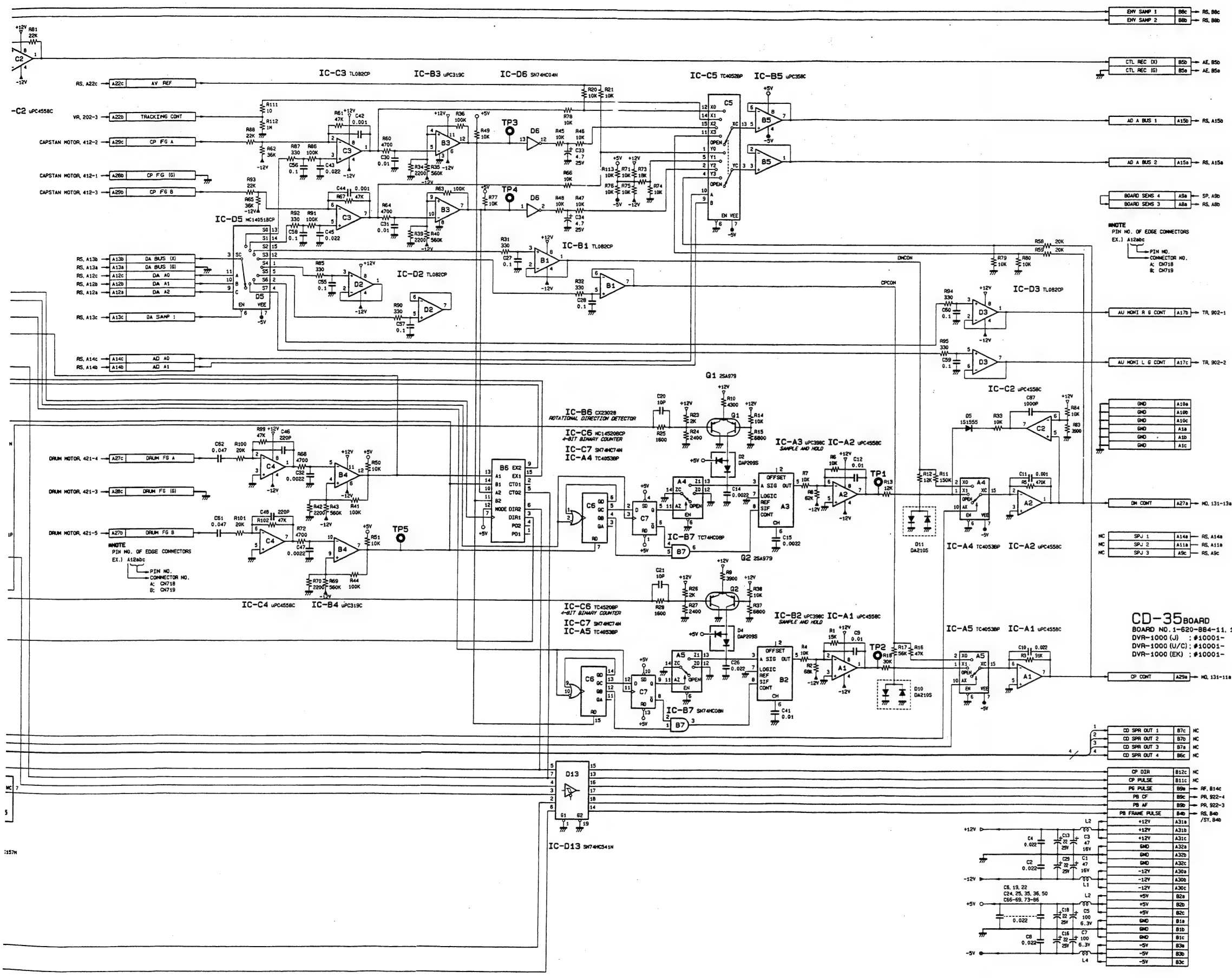

CD-35 BOARD
BOARD NO. 1-620-884-11. 12
DVR-1000 (J) : #10001-
DVR-1000 (U/C) : #10001-
DVR-1000 (E/K) : #10001-

| | | | |
|----|----------------|------|-----------|
| 1 | CD SPR OUT 1 | B7C | NC |
| 2 | CD SPR OUT 2 | B7D | NC |
| 3 | CD SPR OUT 3 | B7A | NC |
| 4 | CD SPR OUT 4 | B6C | NC |
| 5 | CP DIR | B12C | NC |
| 6 | CP PULSE | B11C | NC |
| 7 | FB PULSE | B9B | RF, B14C |
| 8 | FB CF | B9C | PR, 922-4 |
| 9 | FB AF | B9D | PR, 922-3 |
| 10 | FB FRAME PULSE | B4D | RF, B4D |
| 11 | +12V | A31A | |
| 12 | +12V | A31B | |
| 13 | +12V | A31C | |
| 14 | GND | A32A | |
| 15 | GND | A32B | |
| 16 | GND | A32C | |
| 17 | -12V | A32A | |
| 18 | -12V | A32B | |
| 19 | -12V | A32C | |
| 20 | +5V | B2A | |
| 21 | +5V | B2B | |
| 22 | +5V | B2C | |
| 23 | GND | B1A | |
| 24 | GND | B1B | |
| 25 | GND | B1C | |
| 26 | -5V | B3A | |
| 27 | -5V | B3B | |
| 28 | -5V | B3C | |

CARD RACK RS-23 BOARD



RS-23 BOARD CARD RACK

RS-23 BOARD (1-620-885-13)

Component Side

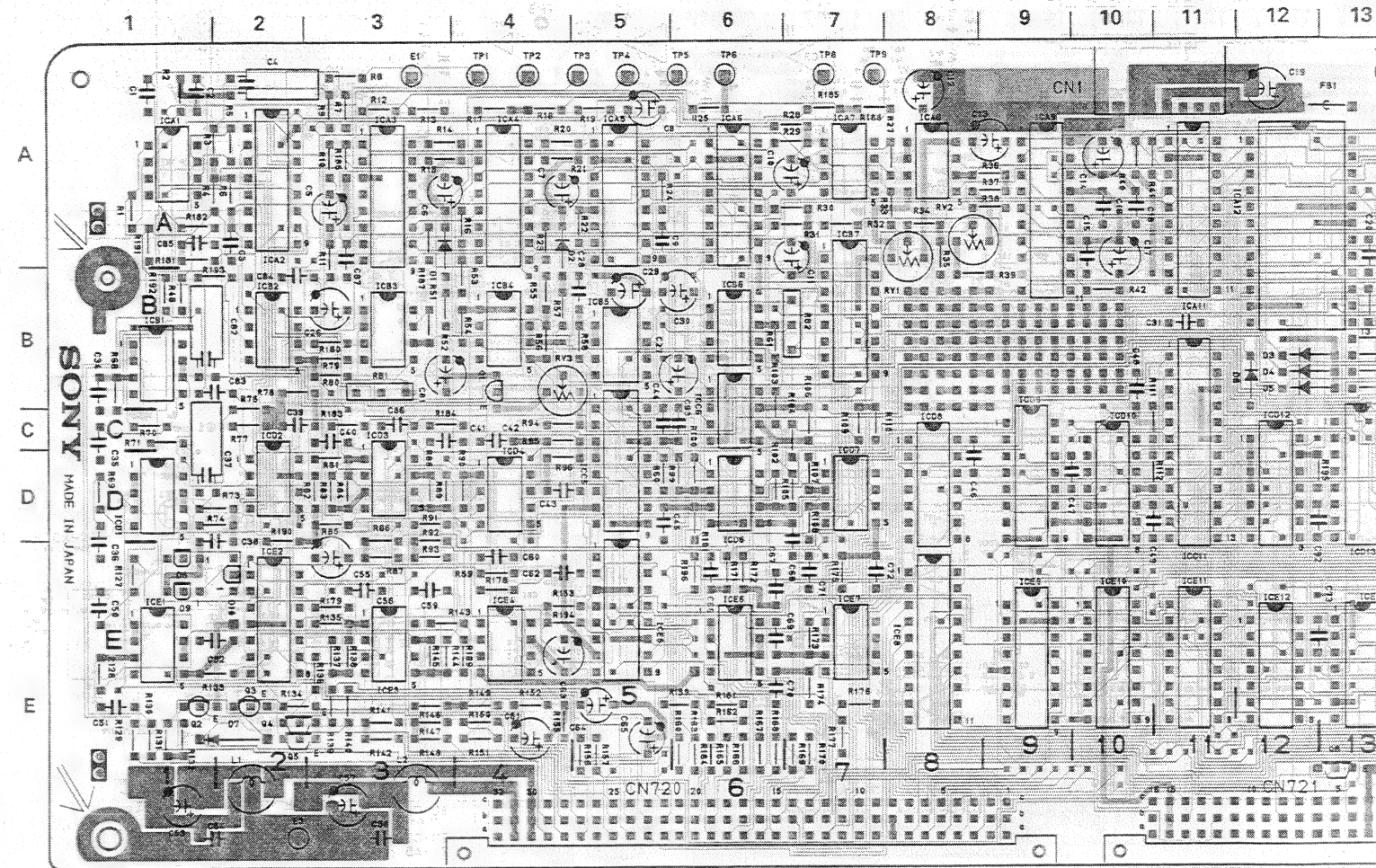

1-620-885-13 COMPONENT SIDE



CS-27 BOARD (1-632-588-11)
Component Side

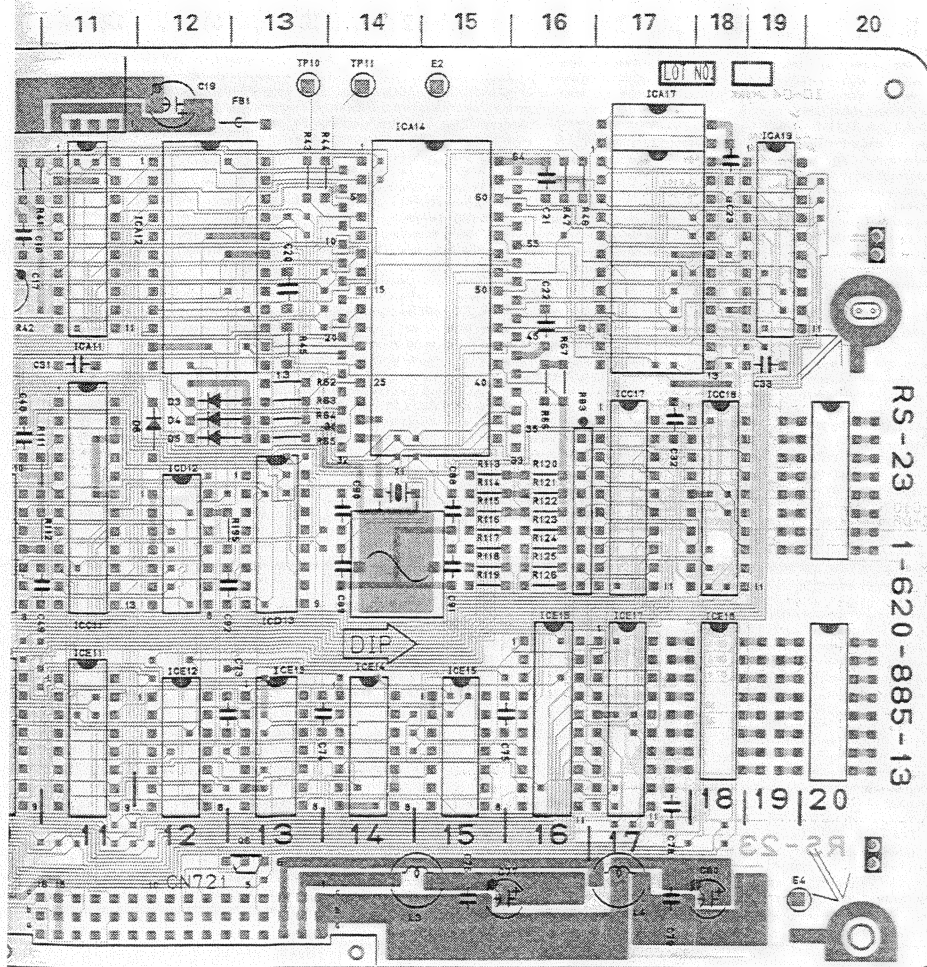

1-620-885-13 SOLDER SIDE

RS-23 (1-620-885-13)

DVR-1000

CN1M A11
CN720M E4
CN721M E11

D1 A3
D2 A4
D3 B12
D4 B12
D5 B12
D6 B12
D7 E2
D8 E1
D9 E1
D10 E2

E1 A3
E2 A15
E3 E2
E4 E20

FB1 A13

Q1 B4
Q2 E1
Q3 E2
Q4 E2
Q5 E2
Q6 E13

RB1 B3
RB2 B7

RV1 A8
RV2 A8
RV3 B4

TP1 A4
TP2 A4
TP3 A5
TP4 A5
TP5 A6
TP6 A6
TP8 A7
TP9 A7
TP10 A13
TP11 A14

X1 C14

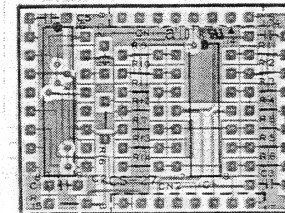

1-632-588-11 COMPONENT SIDE

1-632-588-11 SOLDER SIDE

RS-23 BOARD ; Reel Servo
 CS-27 BOARD ; Auto Tracking

CARD RACK RS-23 BOARD RS-23 BOARD CARD RACK

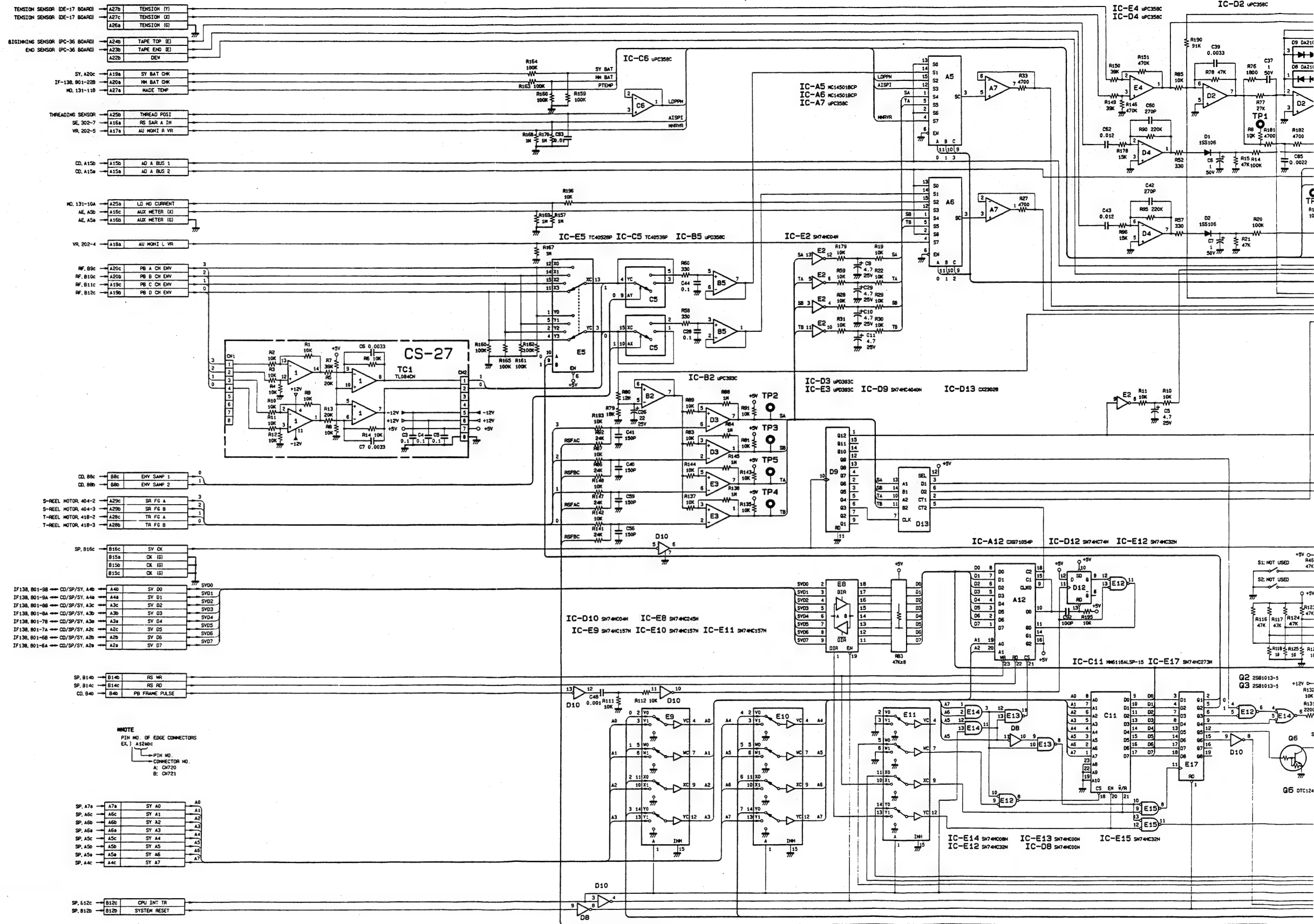

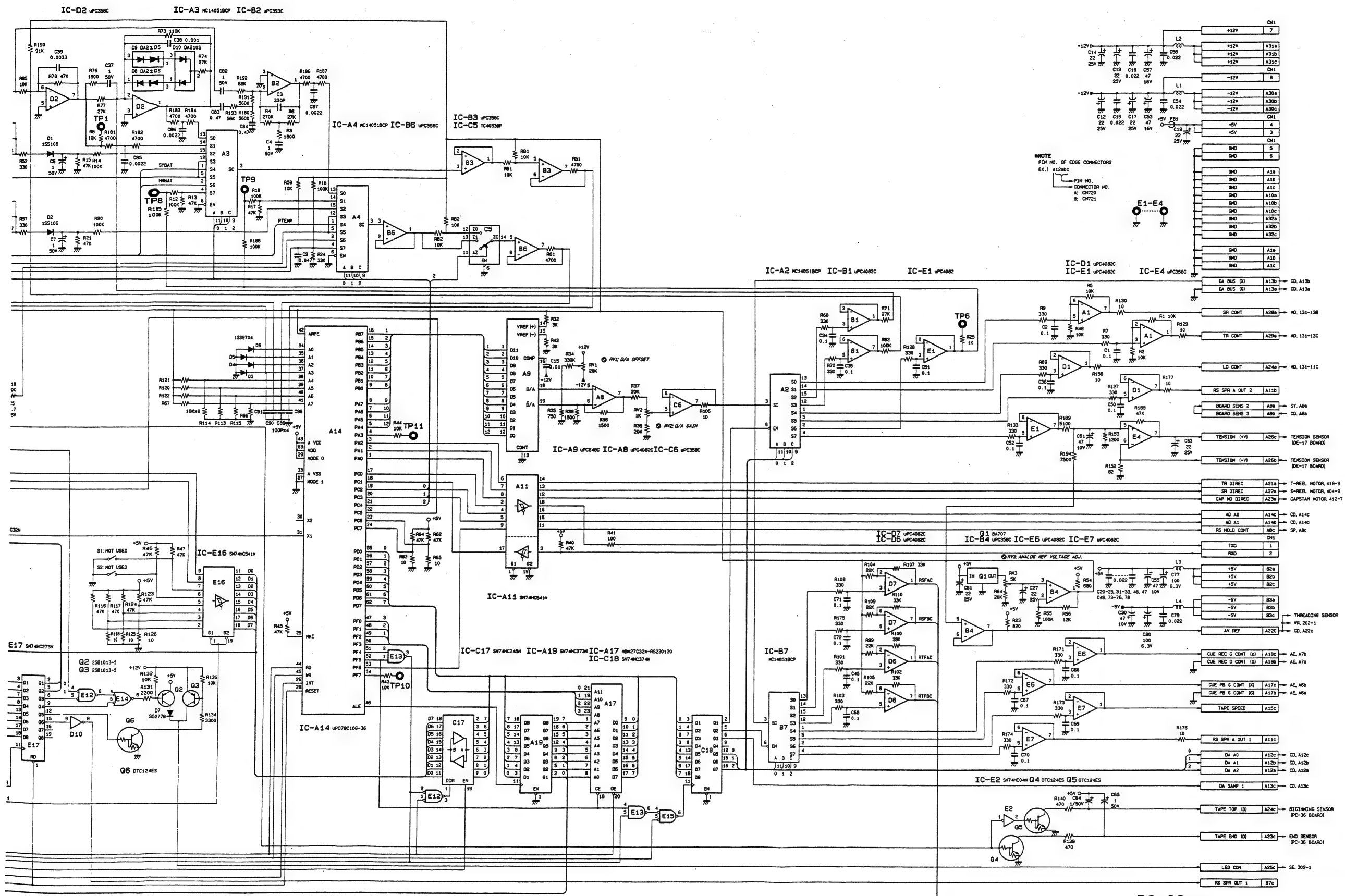

NOTE
PIN NO. OF EDGE CONNECTORS
EX. 1 A128bc
PIN NO. OF CONNECTOR NO.
A: CH720
B: CH721

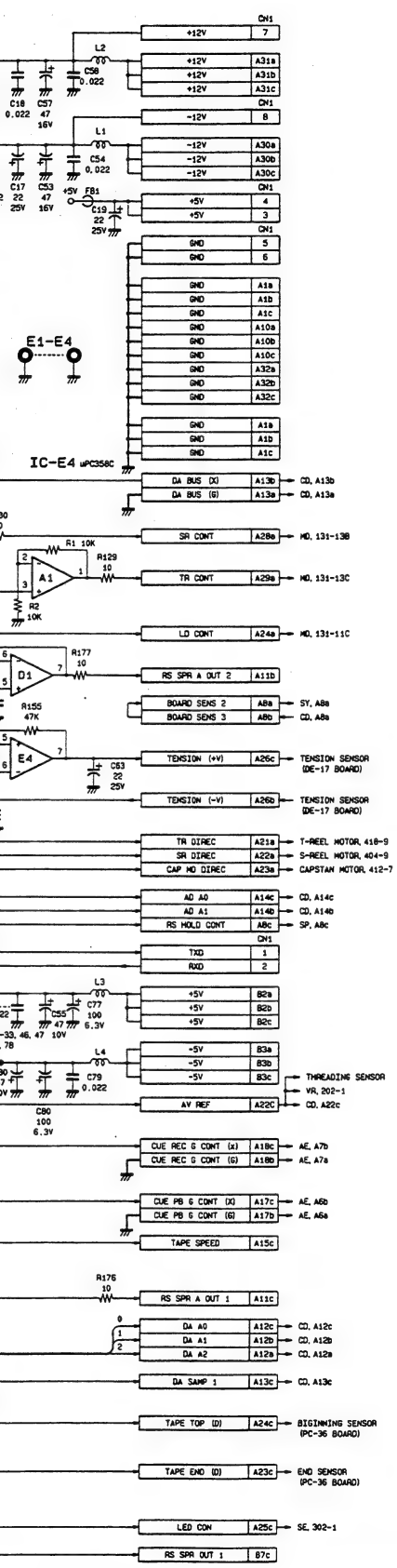

RS-23 BOARD
BOARD NO. 1-620-885-11, 12, 13
DVR-1000 (J) : #10001-
DVR-1000 (U/C) : #10001-
DVR-1000 (EK) : #10001-

SP-01 BOARD (1-620-886-11)
Component Side

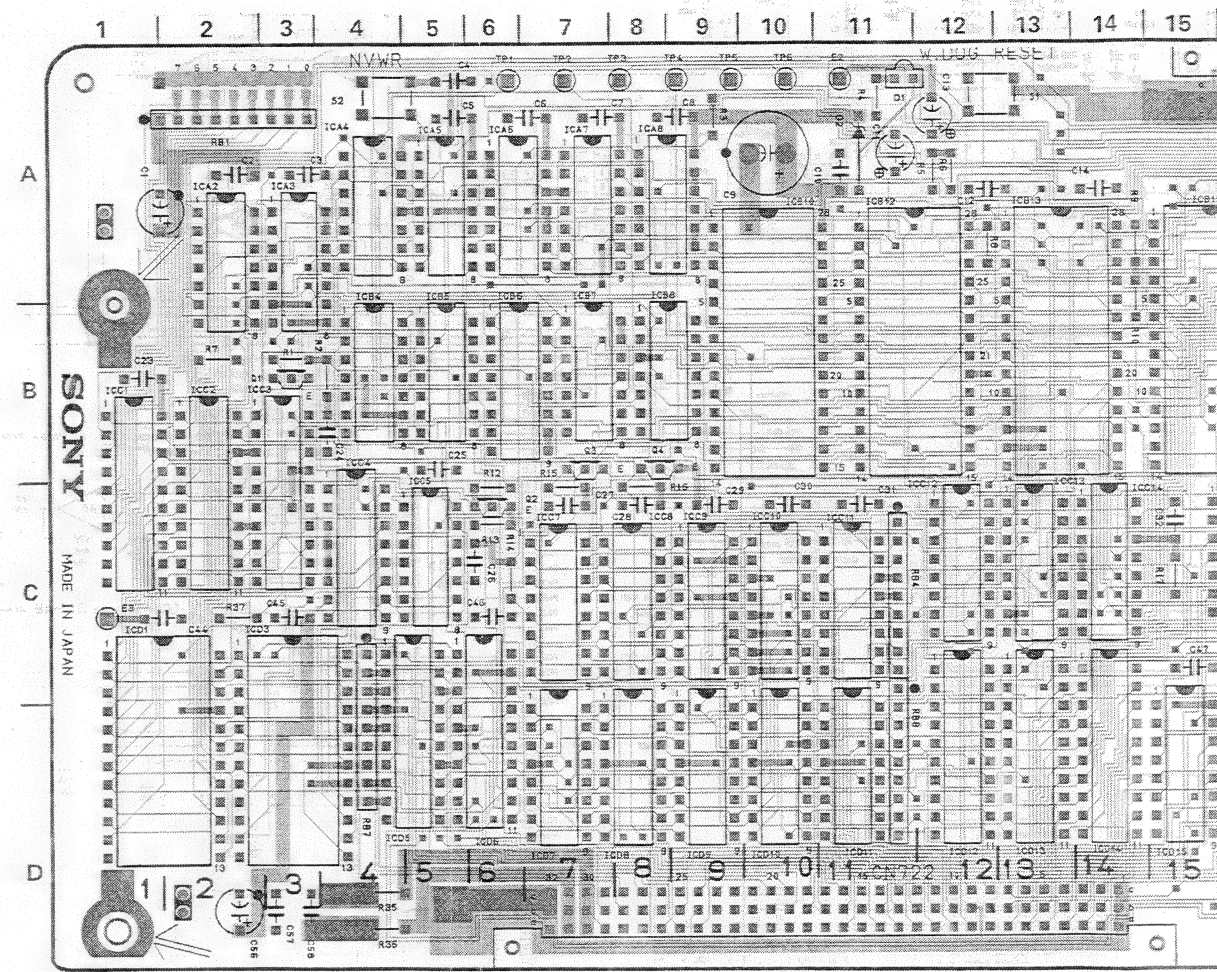

1-620-886-11 COMPONENT SIDE

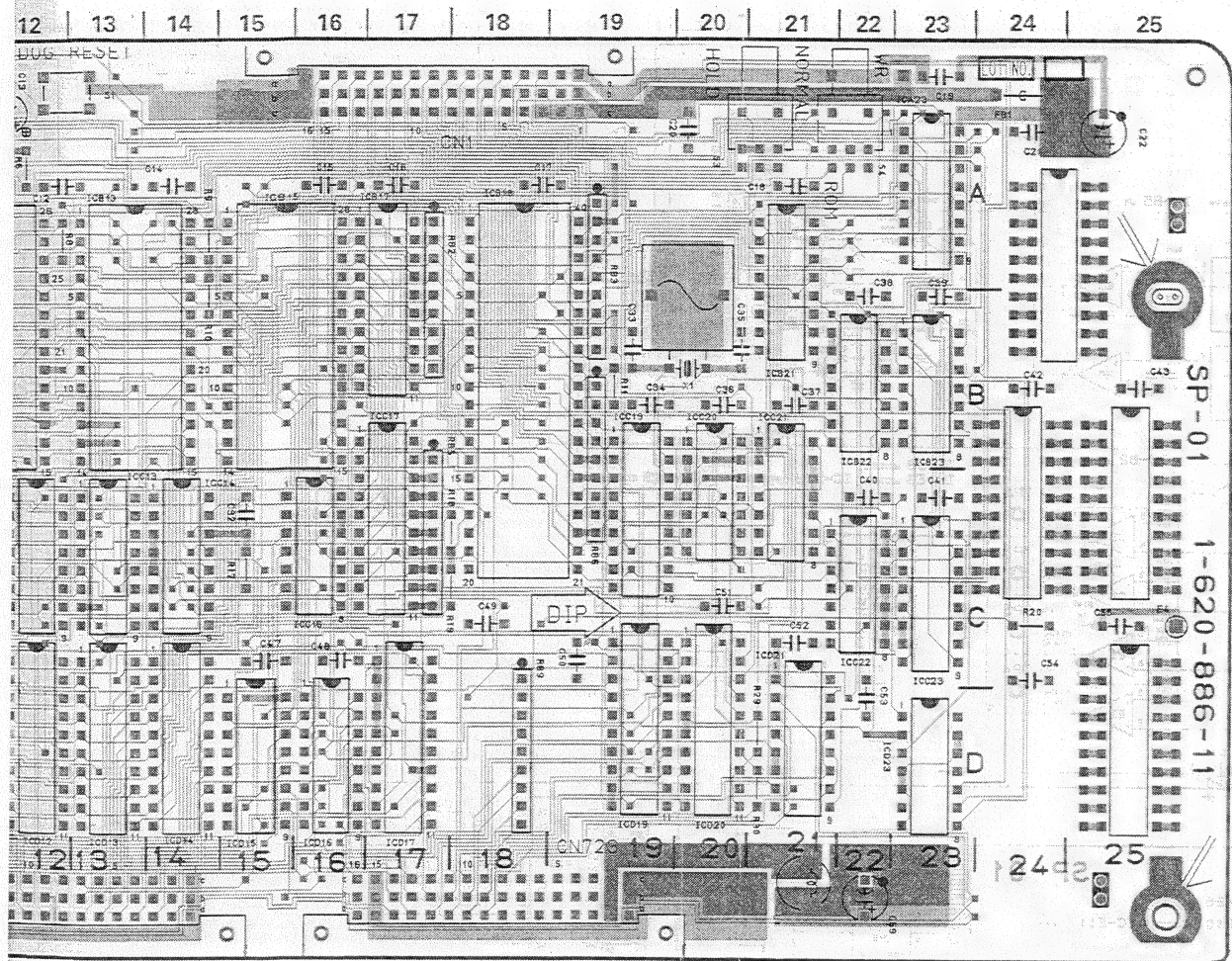

1-620-886-11 SOLDER SIDE

SP-01 (1-620-886-11)

DVR-1000

CN1F A18
CN722M D11
CN723M D19

D1 A11
D2 A11

E2 A11
E3 C1
E4 C25

FB1 A24

Q1 B3
Q2 C6
Q3 B7
Q4 B8

RB1 A2
RB2 A17
RB3 A19
RB4 C11
RB5 C17
RB6 B19
RB7 D4
RB8 D11
RB9 D18

S1 A12
S2 A4
S3 A21
S4 A22

TP1 A6
TP2 A7
TP3 A8
TP4 A9
TP5 A9
TP6 A10

X1 B20

| Ref. No. | Pin No. | |
|----------|---------|-------|
| | +5V | GND |
| IC A2 | 14 | 7 |
| IC A3 | 14 | 7 |
| IC A4 | 14 | 7 |
| IC A5 | 14 | 7 |
| IC A6 | 14 | 7 |
| IC A7 | 14 | 7 |
| IC A8 | 14 | 7 |
| IC A23 | 16 | 8 |
| IC B4 | 14 | 7 |
| IC B5 | 14 | 7 |
| IC B6 | 16 | 8 |
| IC B7 | 14 | 7 |
| IC B8 | 14 | 7 |
| IC B10 | 28 | 14 |
| IC B12 | 28 | 14 |
| IC B13 | 1, 28 | 14 |
| IC B15 | 28 | 14 |
| IC B17 | 20 | 10 |
| IC B18 | 40 | 1, 20 |
| IC B21 | 16 | 8 |
| IC B22 | 14 | 7 |
| IC B23 | 14 | 7 |
| IC C1 | 20 | 10 |
| IC C2 | 20 | 10 |
| IC C3 | 20 | 10 |
| IC C4 | 16 | 8 |
| IC C5 | 14 | 7 |
| IC C7 | 12 | 4 |
| IC C8 | 12 | 4 |
| IC C9 | 12 | 4 |
| IC C10 | 12 | 4 |
| IC C11 | 16 | 8 |
| IC C12 | 16 | 8 |
| IC C13 | 16 | 8 |
| IC C14 | 16 | 8 |
| IC C16 | 14 | 7 |
| IC C17 | 20 | 10 |
| IC C19 | 18 | 9 |
| IC C20 | 14 | 7 |
| IC C21 | 14 | 7 |
| IC C22 | 14 | 7 |
| IC C23 | 16 | 8 |
| IC D1 | 24 | 12 |
| IC D3 | 24 | 12 |
| IC D5 | 20 | 10 |
| IC D6 | 20 | 10 |
| IC D7 | 12 | 4 |
| IC D8 | 12 | 4 |
| IC D9 | 12 | 4 |
| IC D10 | 12 | 4 |
| IC D11 | 12 | 4 |
| IC D12 | 20 | 10 |
| IC D13 | 20 | 10 |
| IC D14 | 20 | 10 |
| IC D15 | 16 | 8 |
| IC D16 | 16 | 8 |
| IC D17 | 20 | 10 |
| IC D19 | 20 | 10 |
| IC D20 | 20 | 10 |
| IC D21 | 16 | 8 |
| IC D23 | 14 | 7 |

SP-01 BOARD
Servo Processor

CARD RACK SP-01 BOARD SP-01 BOARD CARD RACK

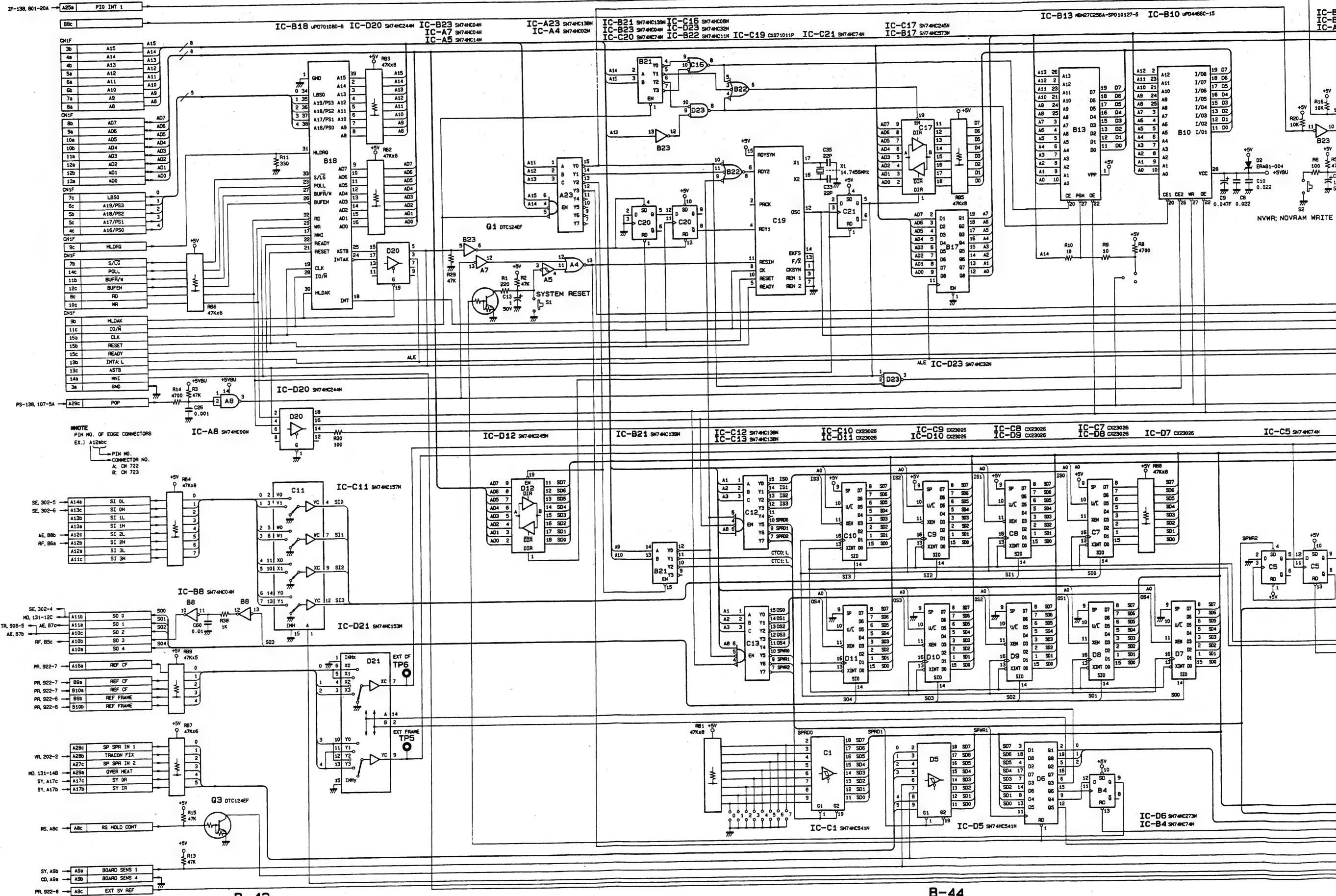

CARD RACK SP-01 BOARD  SP-01 BOARD CARD RACK

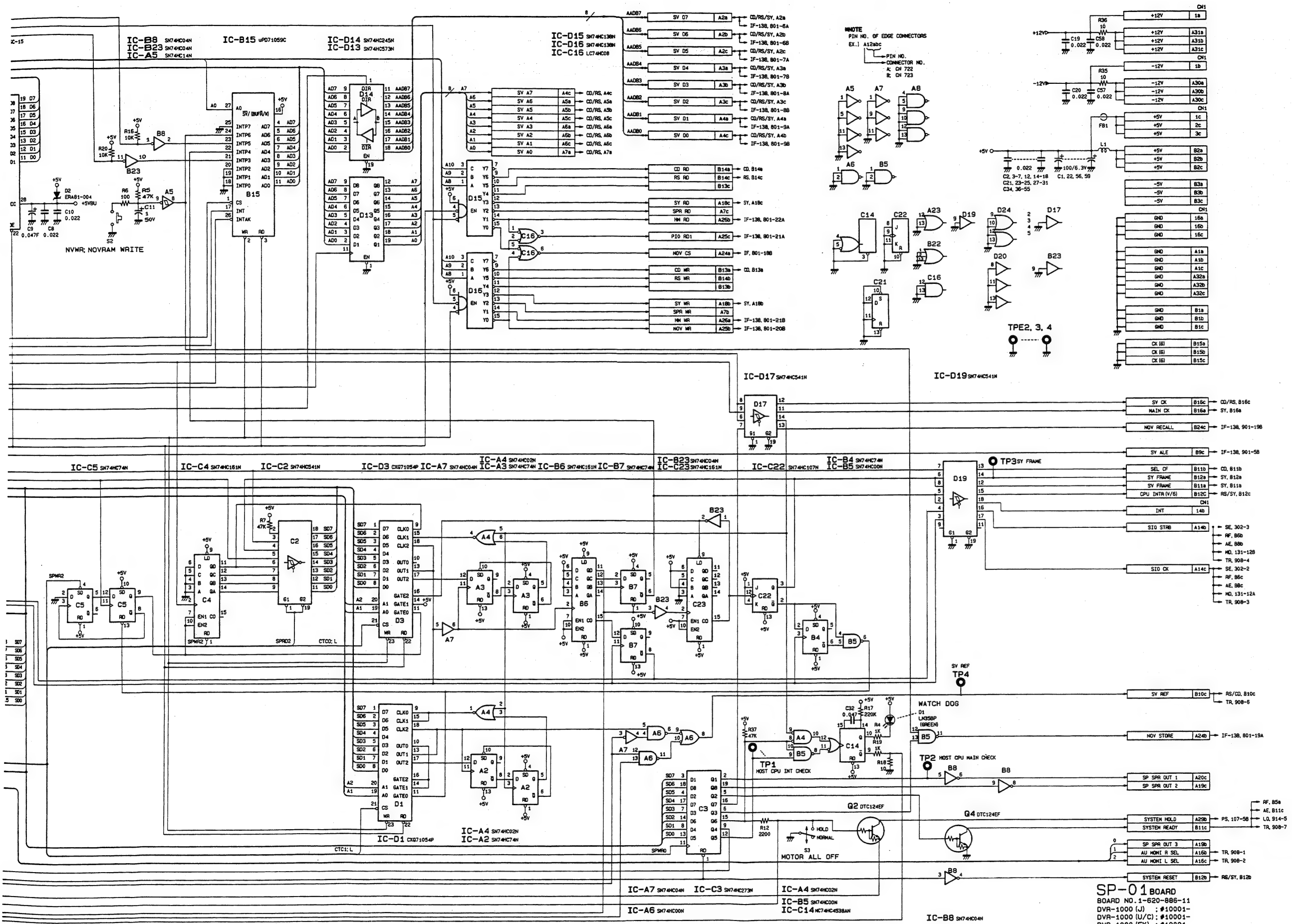

CARD RACK SY-124 BOARD



SY-124 BOARD CARD RACK

SY-124 BOARD (1-624-858-12)

Component Side

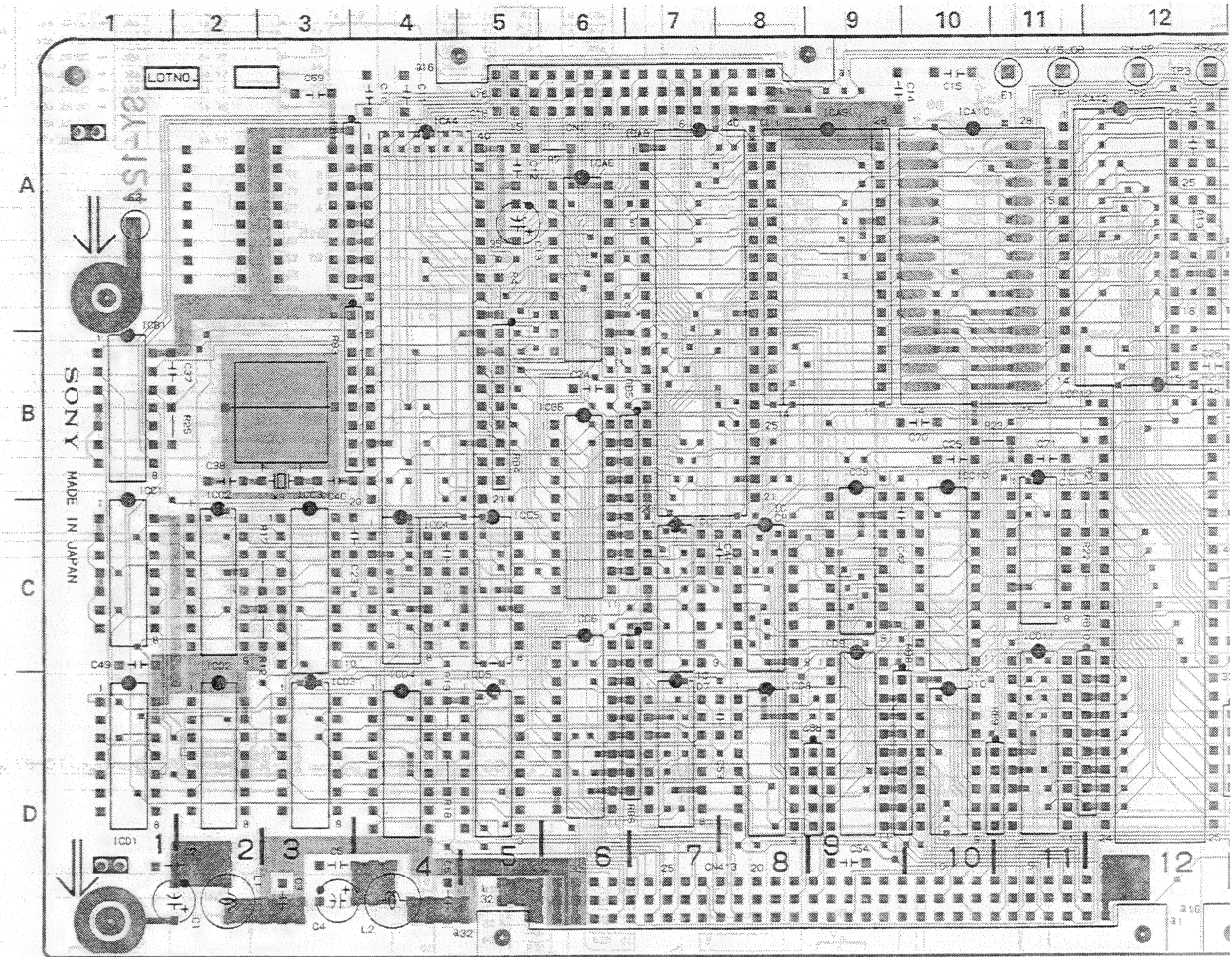

1-624-858-12 COMPONENT SIDE

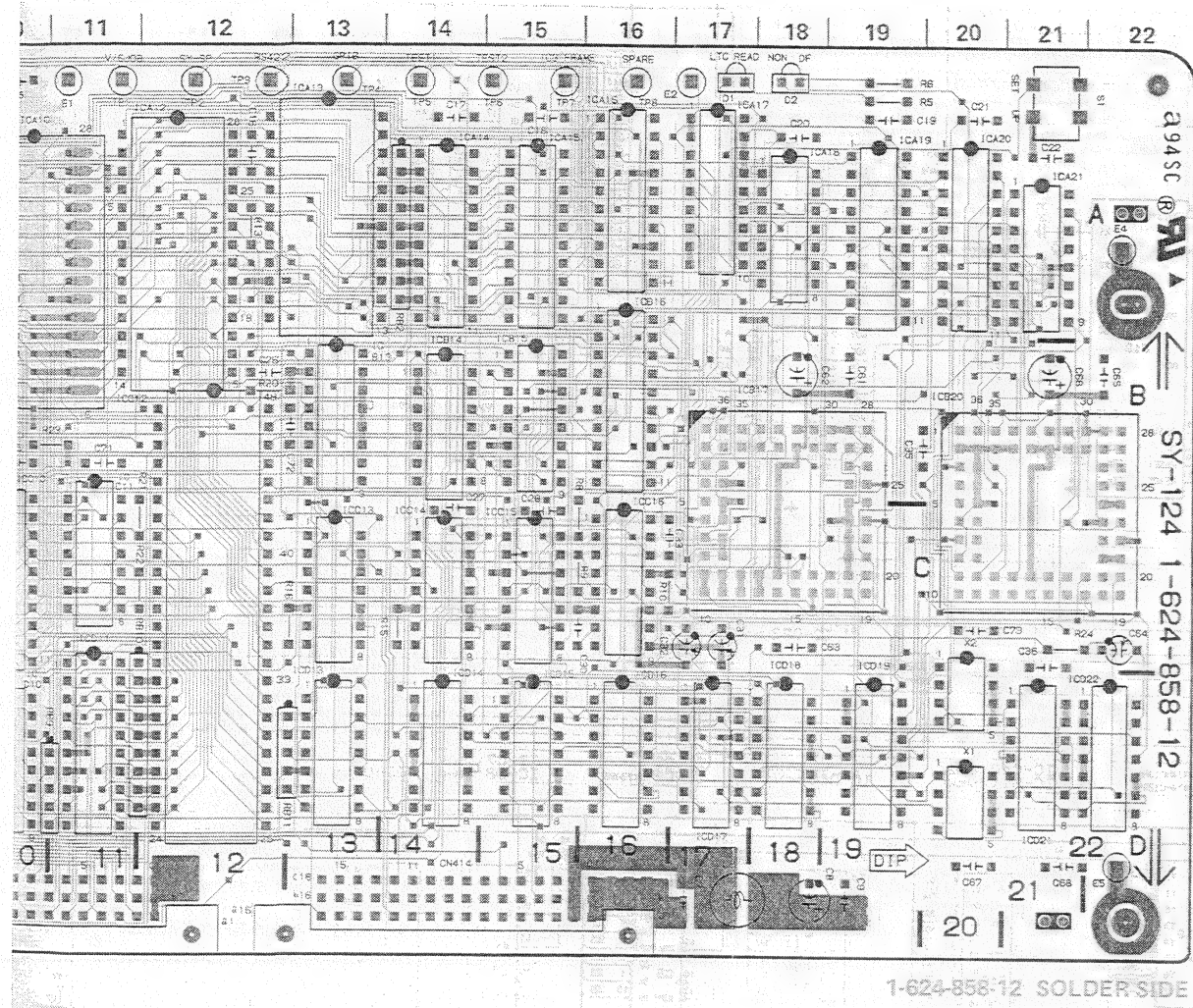

1-624-858-12 SOLDER SIDE

SY-124 (1-624-858-12)

DVR-10
DVR-C10

CN1 A6
CN413 D8
CN414 D14

D1 A17
D2 A18

E1 A11
E2 A17
E3 A1
E4 A22
E5 D22

RB1 A3
RB2 A14
RB3 B3
RB4 B5
RB5 B7
RB6 D7
RB7 D9
RB8 D9
RB9 D11
RB10 D12
RB11 D13

S1 A21

TP1 A11
TP2 A12
TP3 A12
TP4 A13
TP5 A14
TP6 A15
TP7 A15
TP8 A16

X1 D20
X2 D20

SY-124 BOARD

| Ref. No. | Pin No. | |
|----------|---------|--------|
| | +5V | GND |
| IC A4 | 40 | 1, 20 |
| IC A6 | 20 | 10 |
| IC A8 | 30 | 10 |
| IC A9 | 28 | 14 |
| IC A10 | 28 | 14 |
| IC A12 | 28 | 14 |
| IC A13 | 24 | 12 |
| IC A14 | 20 | 10 |
| IC A15 | 20 | 10 |
| IC A16 | 20 | 10 |
| IC A17 | 18 | 9 |
| IC A18 | 14 | 7 |
| IC A19 | 20 | 10 |
| IC A20 | 20 | 10 |
| IC A21 | 16 | 8 |
| IC B1 | 14 | 7 |
| IC B5 | 20 | 10 |
| IC B3 | 16 | 8 |
| IC B4 | 14 | 7 |
| IC B5 | 16 | 8 |
| IC B16 | 20 | 10 |
| IC B17 | 47, 51 | 40, 54 |
| IC B20 | 47, 51 | 40, 54 |
| IC C1 | 14 | 7 |
| IC C2 | 16 | 8 |
| IC C3 | 18 | 9 |
| IC C4 | 14 | 7 |
| IC C5 | 14 | 7 |
| IC C7 | 16 | 8 |
| IC C8 | 16 | 8 |
| IC C9 | 16 | 8 |
| IC C10 | 20 | 10 |
| IC C11 | 14 | 7 |
| IC C13 | 14 | 7 |
| IC C14 | 14 | 7 |
| IC C15 | 14 | 7 |
| IC C16 | 16 | 8 |
| IC D1 | 14 | 7 |
| IC D2 | 14 | 7 |
| IC D3 | 14 | 7 |
| IC D4 | 16 | 8 |
| IC D5 | 16 | 8 |
| IC D6 | 20 | 10 |
| IC D7 | 14 | 7 |
| IC D8 | 16 | 8 |
| IC D9 | 20 | 10 |
| IC D10 | 16 | 8 |
| IC D13 | 14 | 7 |
| IC D14 | 14 | 7 |
| IC D15 | 14 | 7 |
| IC D16 | 14 | 7 |
| IC D17 | 14 | 7 |
| IC D18 | 14 | 7 |
| IC D19 | 14 | 7 |
| IC D21 | 14 | 7 |
| IC D22 | 14 | 7 |

SY-124 BOARD (1/2)
System Controller

CARD RACK SY-124 (1/2) BOARD  **SY-124 (1/2) BOARD CARD RACK**

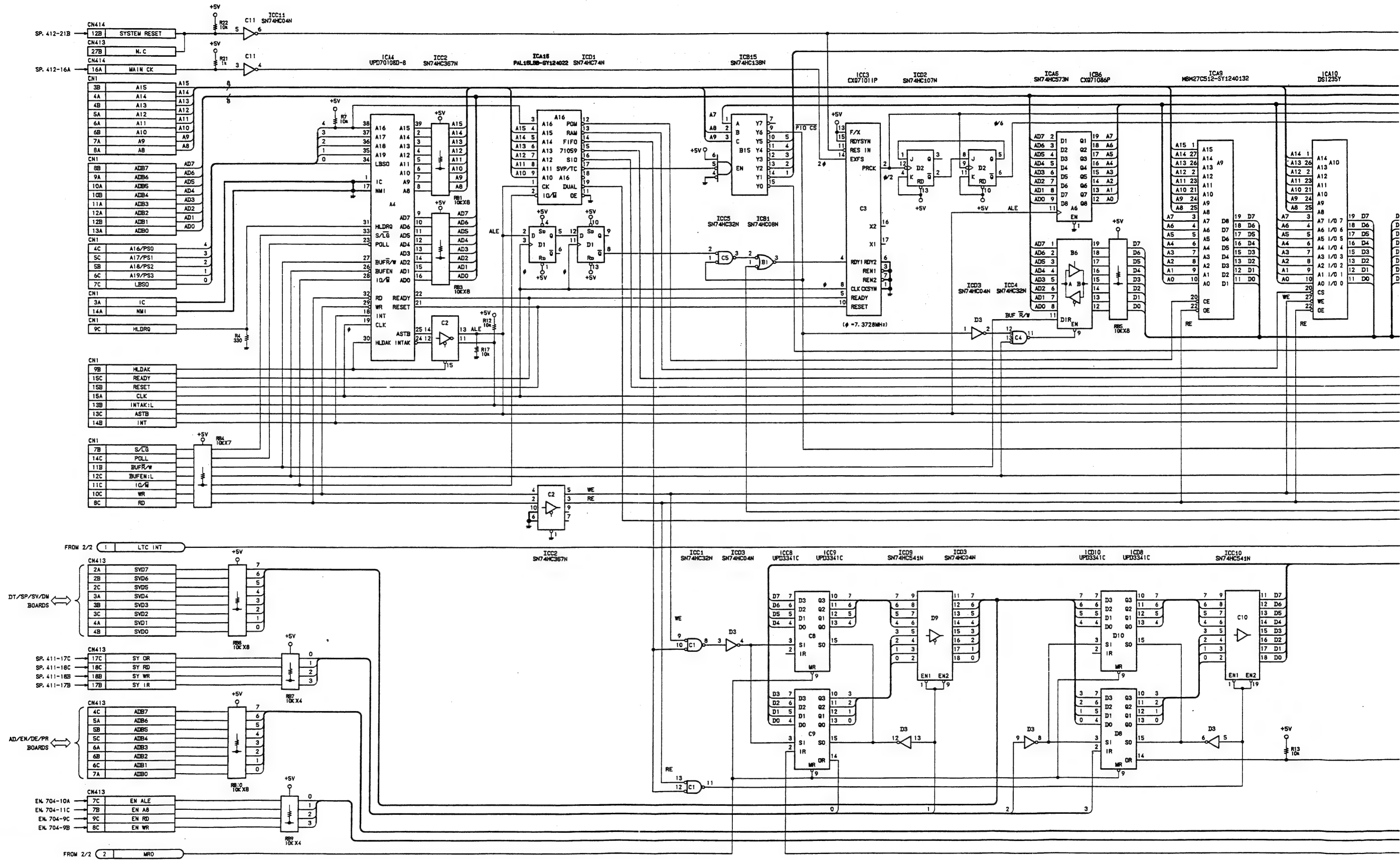

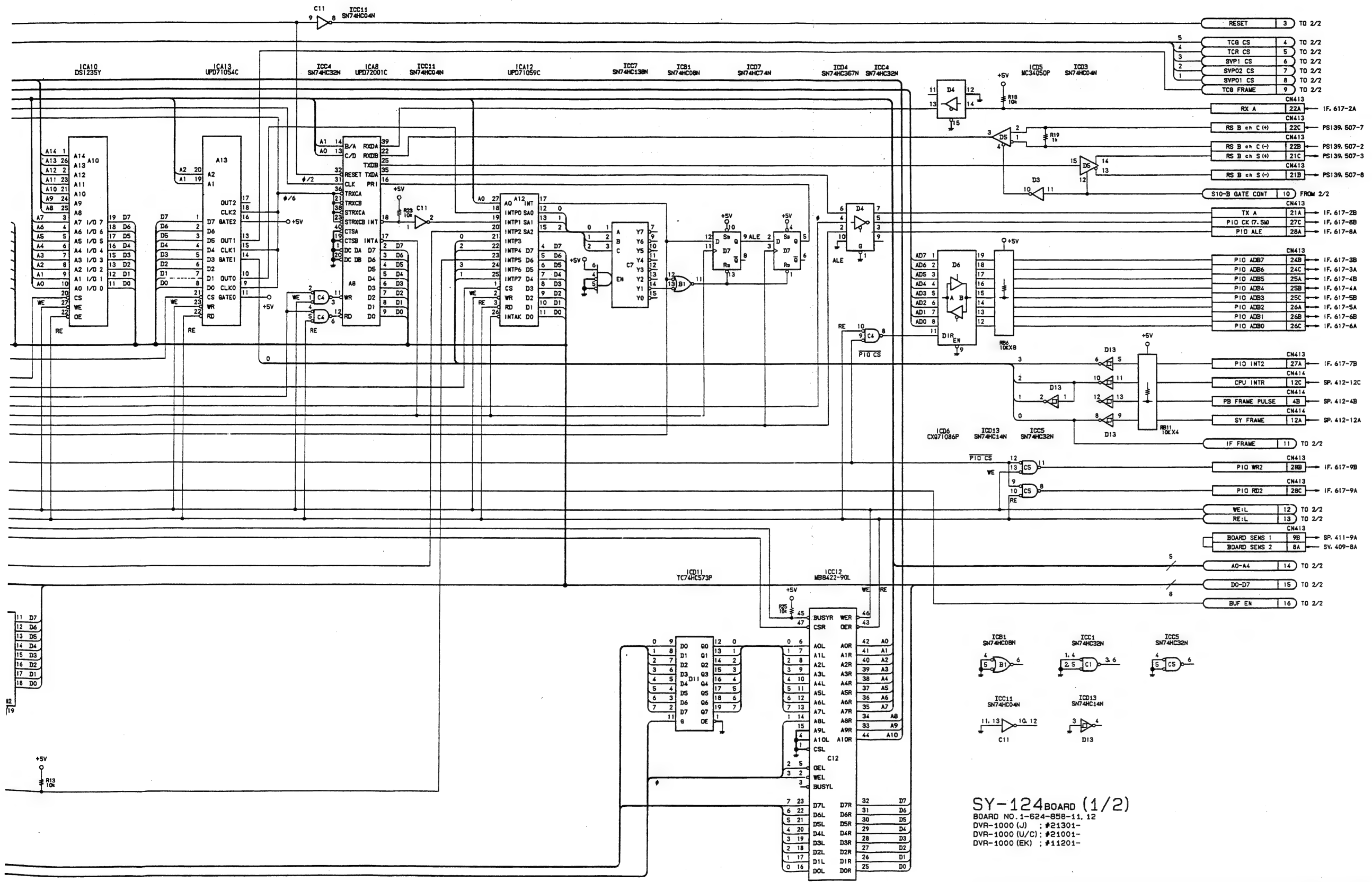

SY-124BOARD (1/2)
 BOARD NO. 1-624-858-11, 12
 DVR-1000 (J) : #21301-
 DVR-1000 (U/C) : #21001-
 DVR-1000 (EK) : #11201-

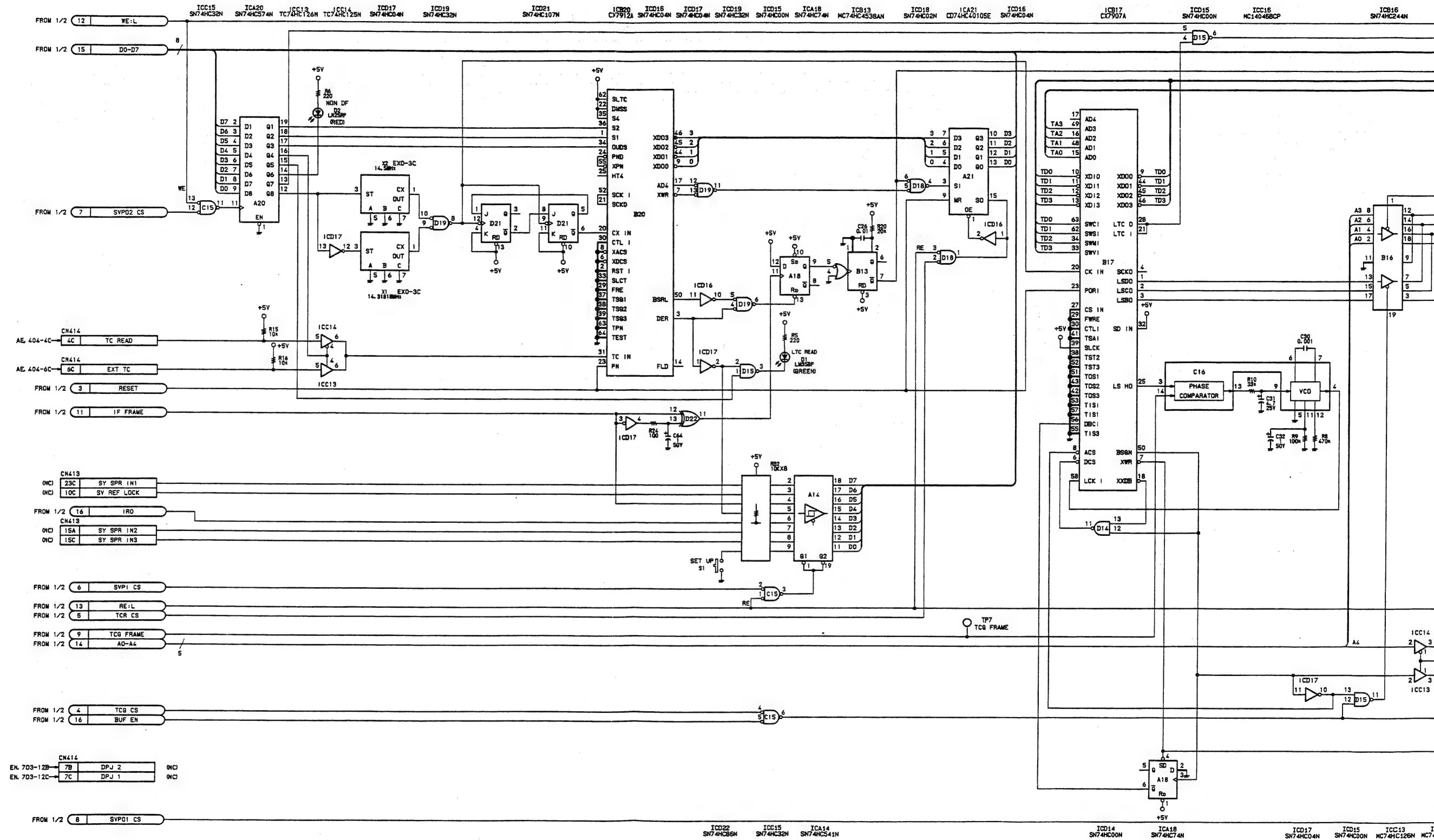

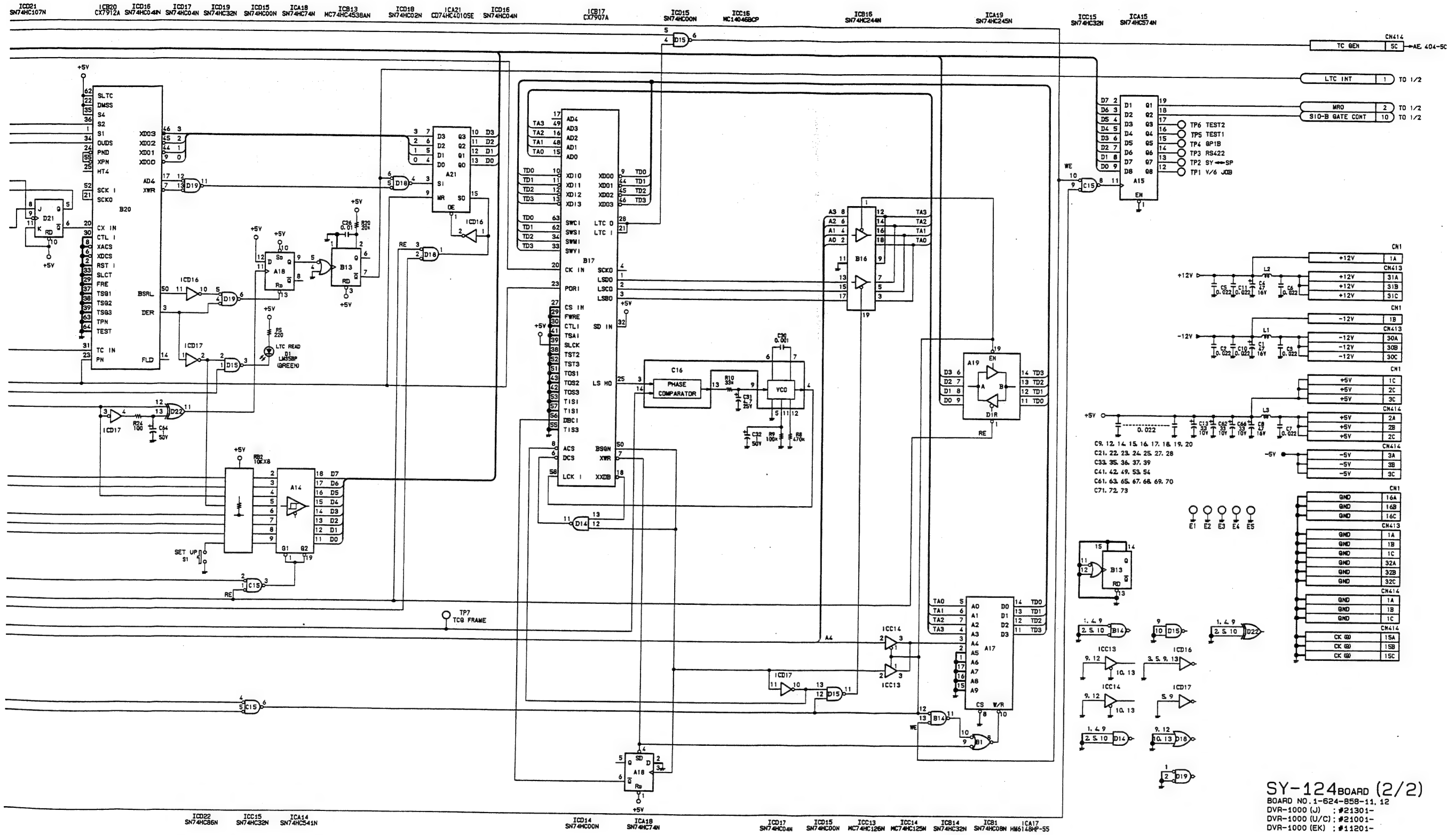

LO-05 BOARD (1-620-905-12)
Component Side

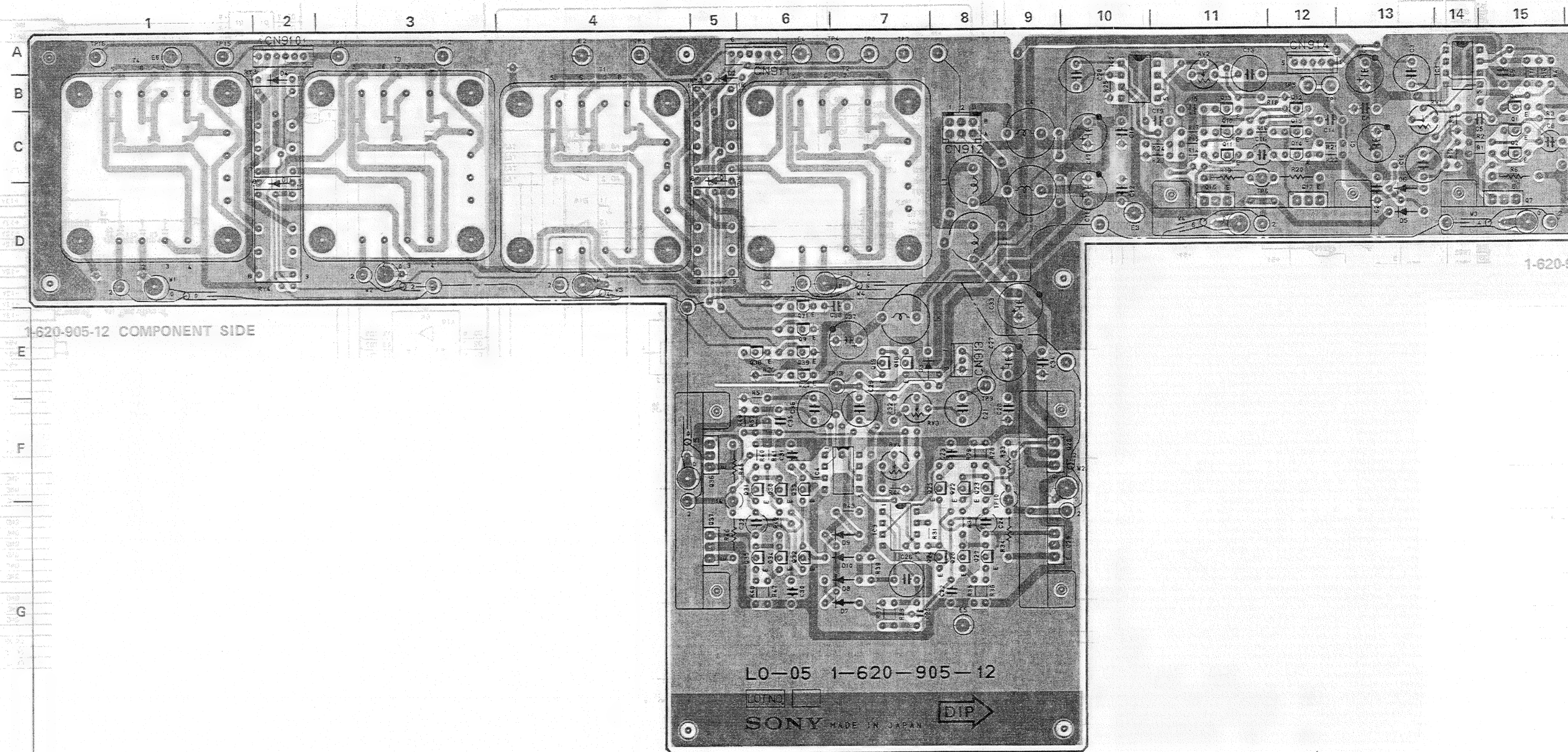

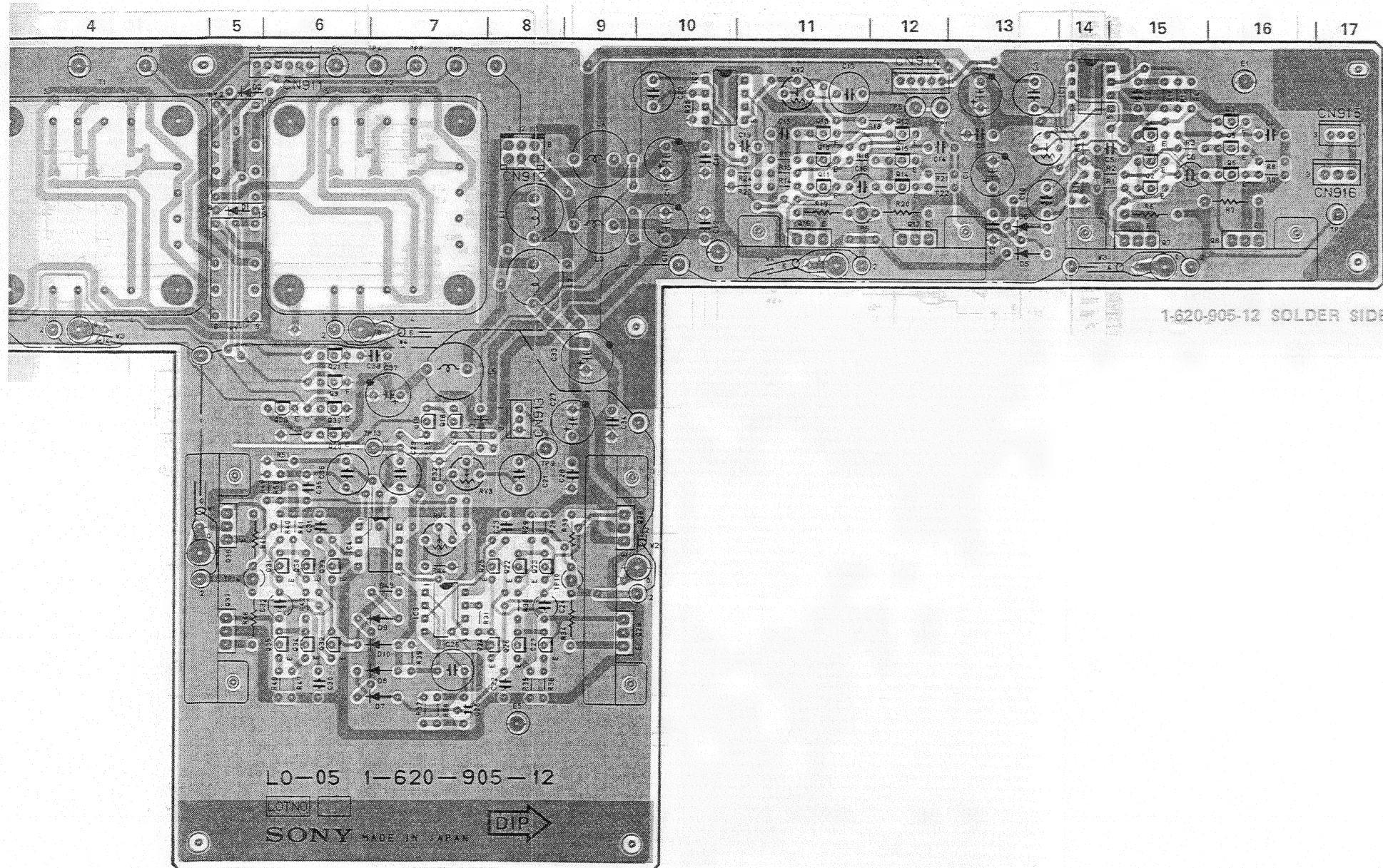

1-620-905-12 SOLDER SIDE

LO-05 (1-620-905-11,12)

DVR-1000

| | | | |
|------------|-----|------|-----|
| CN910M A2 | Q24 | G8 | |
| CN911M A6 | Q25 | F8 | |
| CN912M C8 | Q26 | G8 | |
| CN913M E8 | Q27 | G8 | |
| CN914M B12 | Q28 | F9 | |
| CN915M C17 | Q29 | G9 | |
| CN916M C17 | Q30 | F6 | |
| | Q31 | F6 | |
| D1 | D5 | Q32 | G6 |
| D2 | B5 | Q33 | F6 |
| D3 | E7 | Q34 | G6 |
| D4 | B2 | Q35 | G6 |
| D5 | D13 | Q36 | F5 |
| D6 | D13 | Q37 | G5 |
| D7 | C7 | Q38 | E6 |
| D8 | C7 | Q39 | E6 |
| D9 | C7 | | |
| D10 | G7 | RV1 | C13 |
| D11 | D2 | RV2 | B11 |
| | | RV3 | F7 |
| | | RV4 | F7 |
| E1 | A16 | | |
| E2 | A4 | | |
| E3 | D10 | RY1 | D5 |
| E4 | A6 | RY2 | C5 |
| E5 | G8 | RY3 | C2 |
| E6 | A1 | RY4 | D2 |
| IC1 | B14 | T1 | D4 |
| IC2 | A10 | T2 | D7 |
| IC3 | G7 | T3 | D3 |
| IC4 | F7 | T4 | D1 |
| Q1 | C15 | TP1 | B12 |
| Q2 | C15 | TP2 | C17 |
| Q3 | B16 | TP3 | A4 |
| Q4 | C15 | TP4 | A7 |
| Q5 | C16 | TP5 | B12 |
| Q6 | C16 | TP6 | C11 |
| Q7 | D15 | TP7 | A7 |
| Q8 | D16 | TP8 | A7 |
| Q9 | E6 | TP9 | E8 |
| Q10 | C11 | TP10 | G9 |
| Q11 | C11 | TP11 | A3 |
| Q12 | C12 | TP12 | A3 |
| Q13 | C11 | TP13 | E7 |
| Q14 | C12 | TP14 | G3 |
| Q15 | C12 | TP15 | A1 |
| Q16 | D11 | TP16 | A1 |
| Q17 | D12 | | |
| Q18 | F7 | | |
| Q19 | E7 | | |
| Q20 | E6 | | |
| Q21 | E6 | | |
| Q22 | F8 | | |
| Q23 | F8 | | |

LO-05 BOARD
Audio Line Out

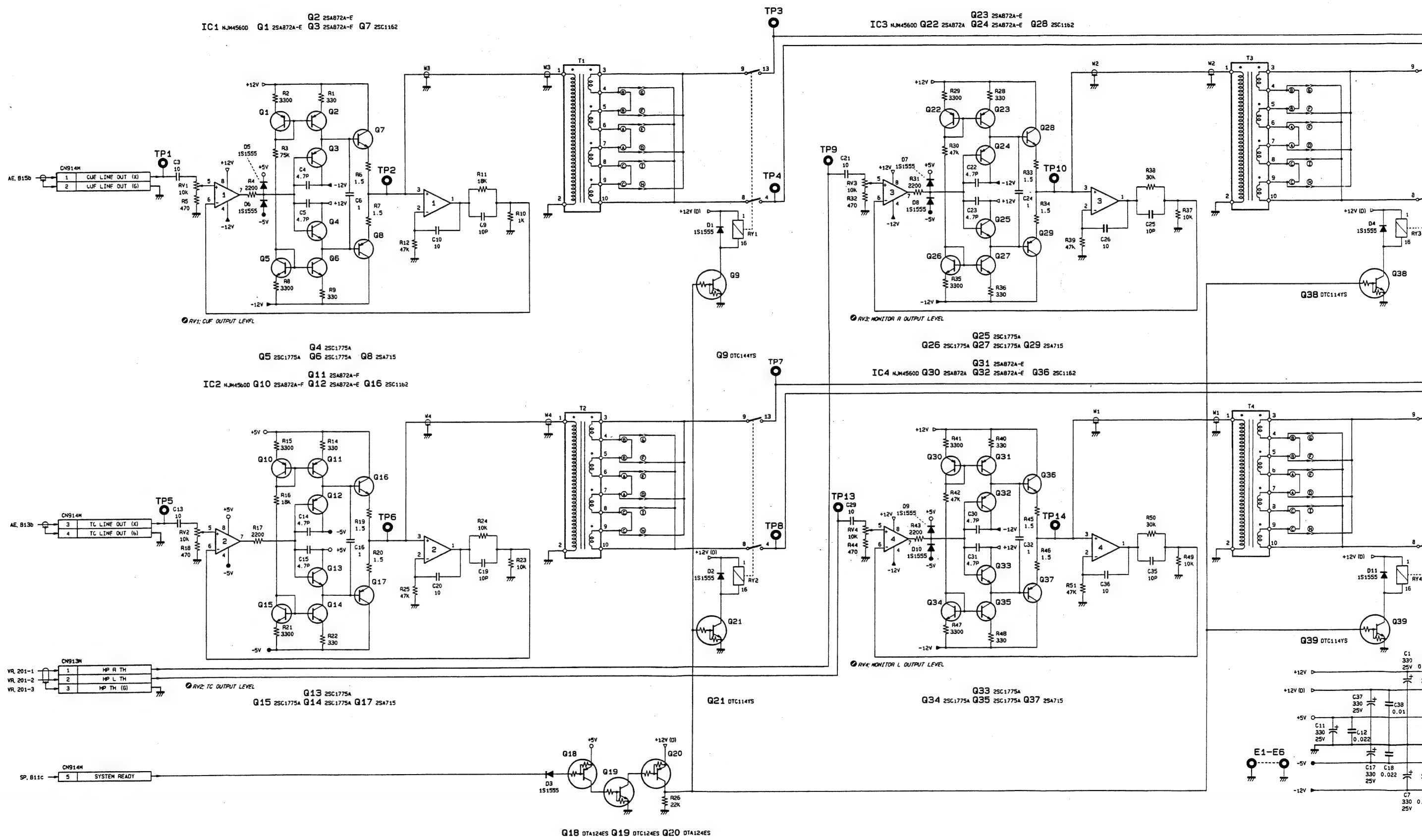

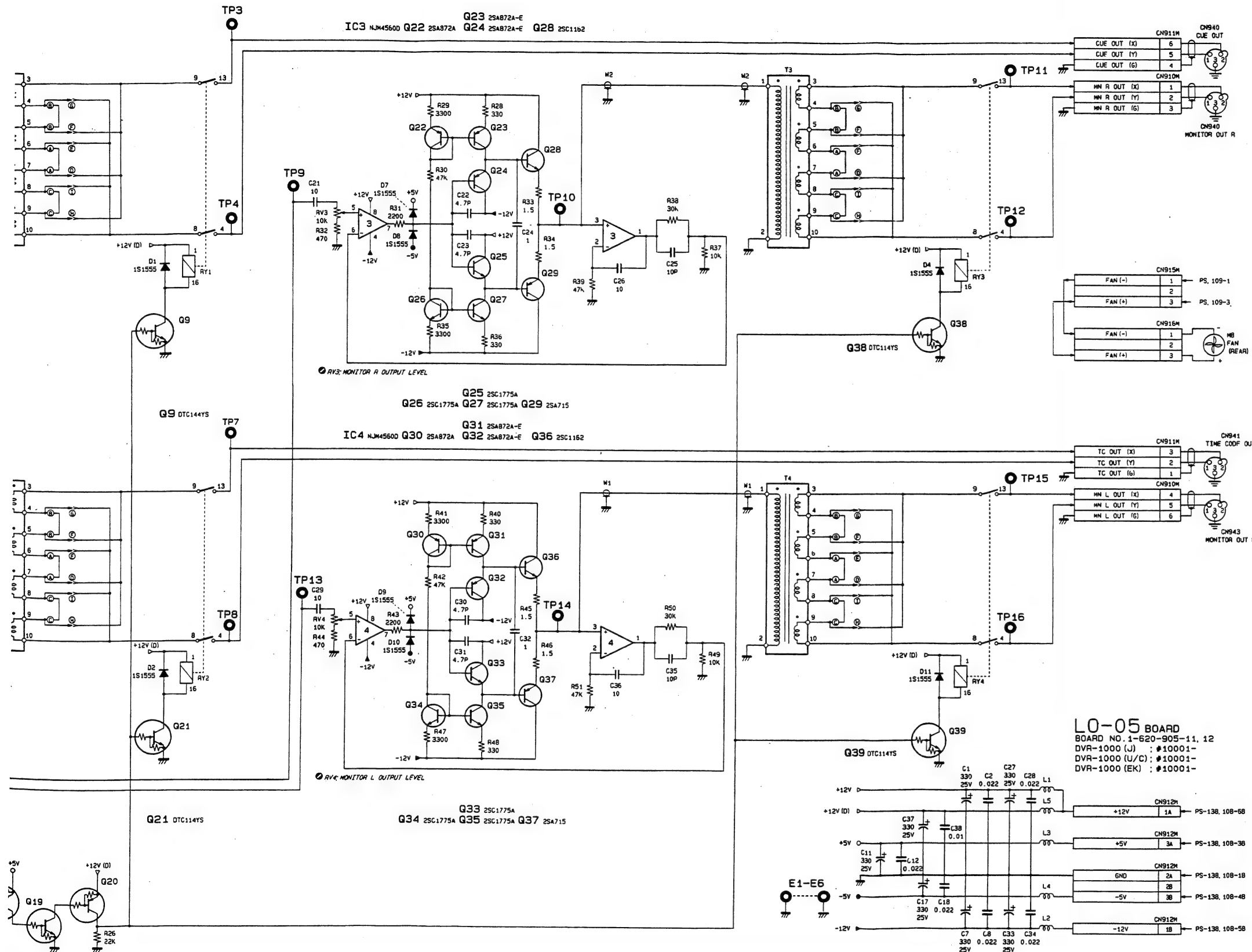

| Ref. No. | Pin No. | | | |
|----------|---------|-----|-----|------|
| | +12V | +5V | -5V | -12V |
| IC 1 | 8 | 8 | 4 | 4 |
| IC 2 | 8 | 8 | 4 | 4 |
| IC 3 | 8 | 8 | 4 | 4 |
| IC 4 | 8 | 8 | 4 | 4 |

L0-05 BOARD
 BOARD NO. 1-620-905-11, 12
 DVR-1000 (J) : #10001-
 DVR-1000 (U/C) : #10001-
 DVR-1000 (EK) : #10001-

TA124ES Q19 DTC124ES Q20 DT124ES

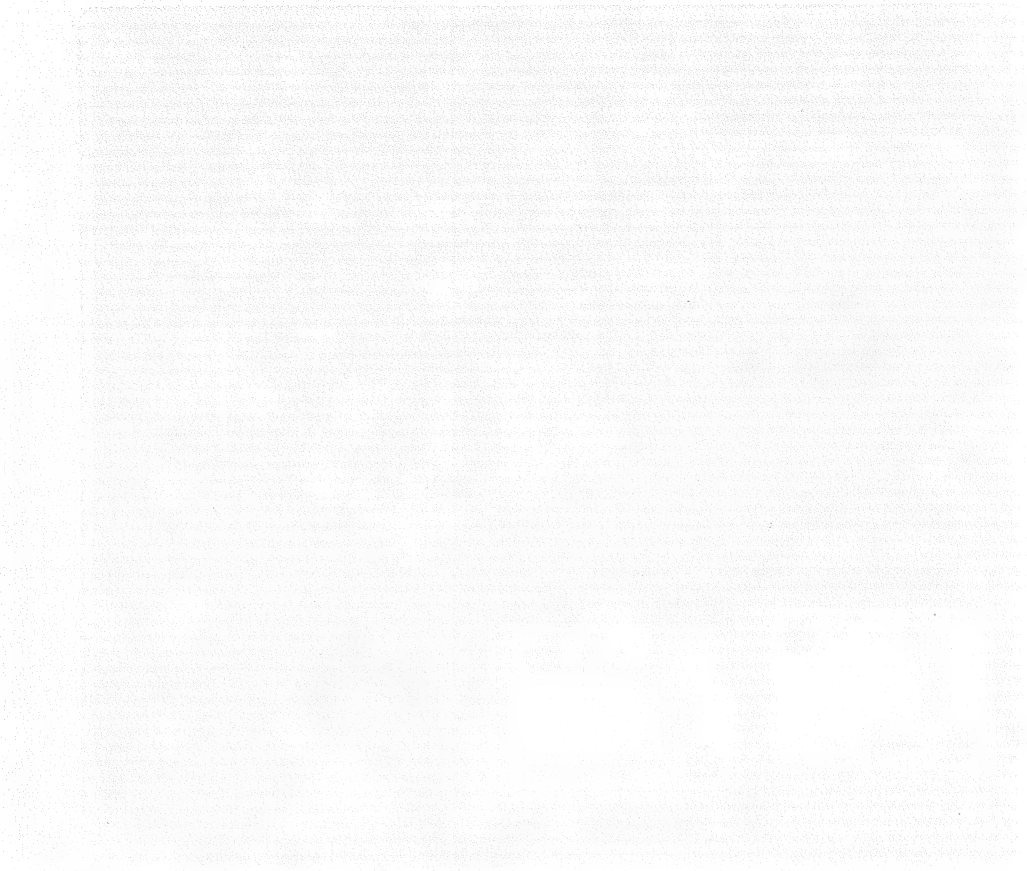

TR-40 BOARD

TR-40 BOARD (1-620-903-13)
Component Side

700

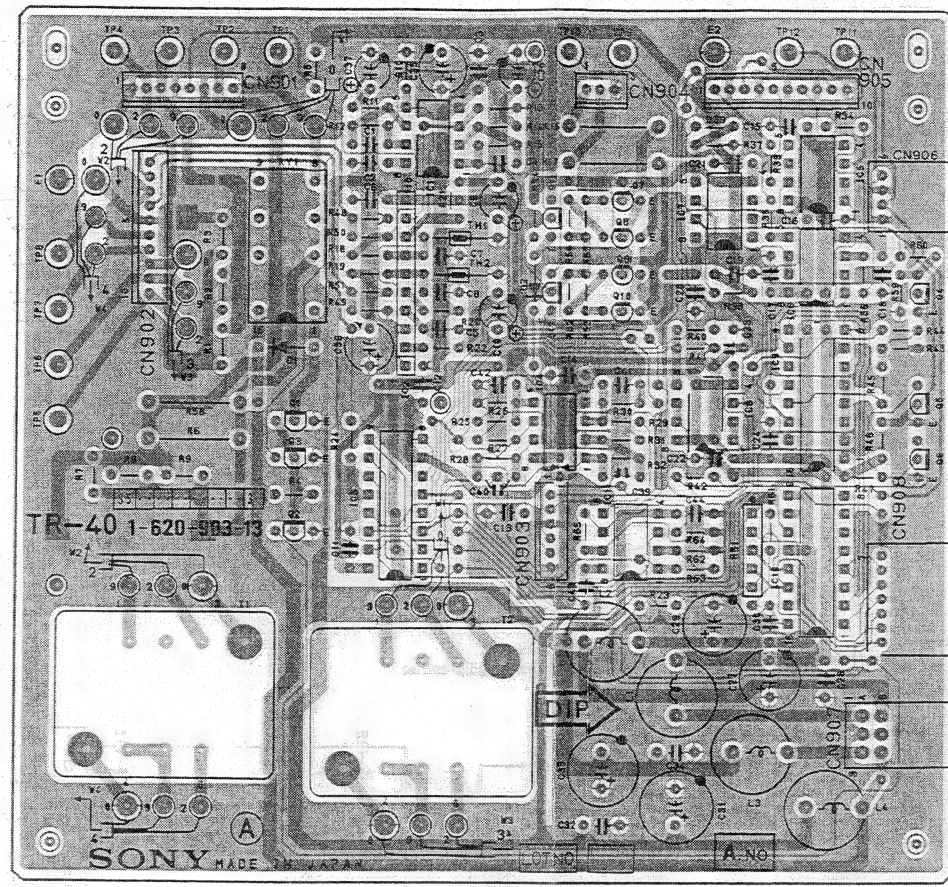

1-620-903-13 COMPONENT SIDE

1-620-903-13 SOLDER SIDE

TR-40 BOARD
Input Transformer

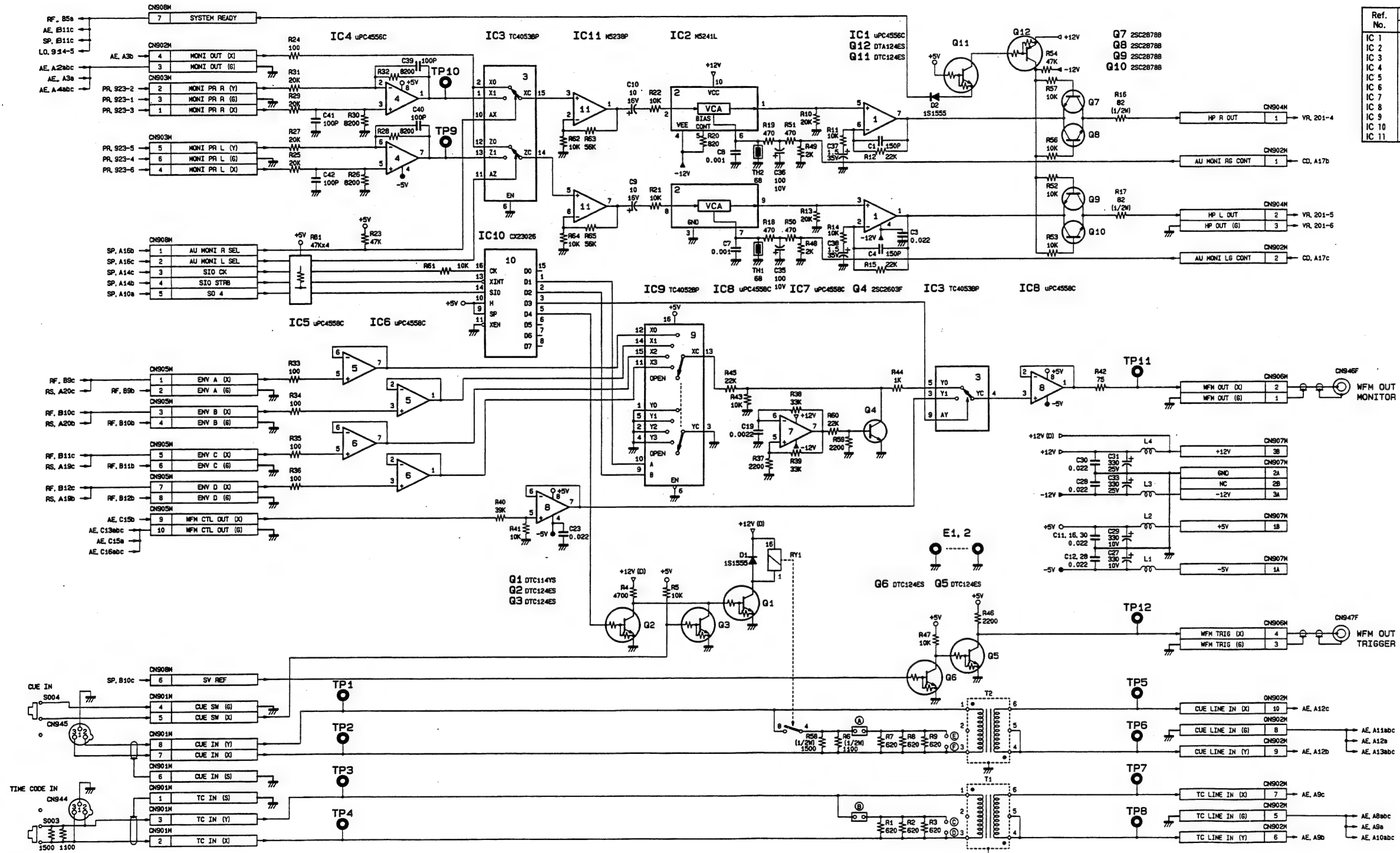

| Ref. No. | Pin No. | | | | |
|----------|---------|-----|-----|-----|------|
| | +12V | +5V | GND | -5V | -12V |
| IC 1 | 8 | | | | 4 |
| IC 2 | 10 | | 3 | | 4 |
| IC 3 | | 16 | 8 | 7 | |
| IC 4 | | 8 | | 4 | |
| IC 5 | | 8 | | 4 | |
| IC 6 | | 8 | | 4 | |
| IC 7 | | 8 | | 4 | |
| IC 8 | | 8 | | 4 | |
| IC 9 | | 16 | 8 | 7 | |
| IC 10 | | 12 | 4 | | |
| IC 11 | 8 | | | | 4 |

TR-40 BOARD
BOARD NO. 1-620-903-11, 12, 13
DVR-1000 (J) : #10001-
DVR-1000 (U/C) : #10001-
DVR-1000 (EK) : #10001-

PR-87 BOARD (1-620-906-11)
Component Side

ORACE 04-RT
Legend Transducer

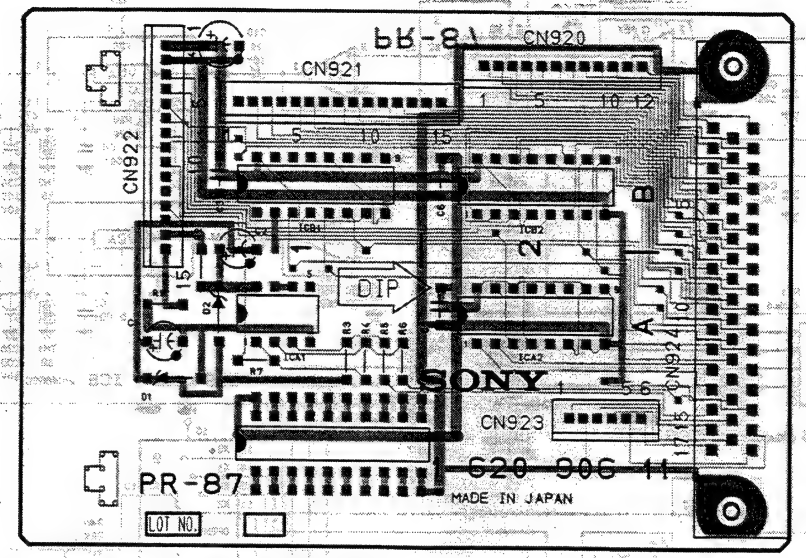

| Ref. No. | Pin No. | |
|----------|-----------------------------|-----|
| | +5V | GND |
| IC A1 | Refer to schematic diagram. | |
| IC A2 | 16 | 8 |
| IC B1 | 16 | 8 |
| IC B2 | 16 | 8 |

1-620-906-11 COMPONENT SIDE
1-620-906-11 SOLDER SIDE

PR-87 BOARD
Processor Interface (CN-A)

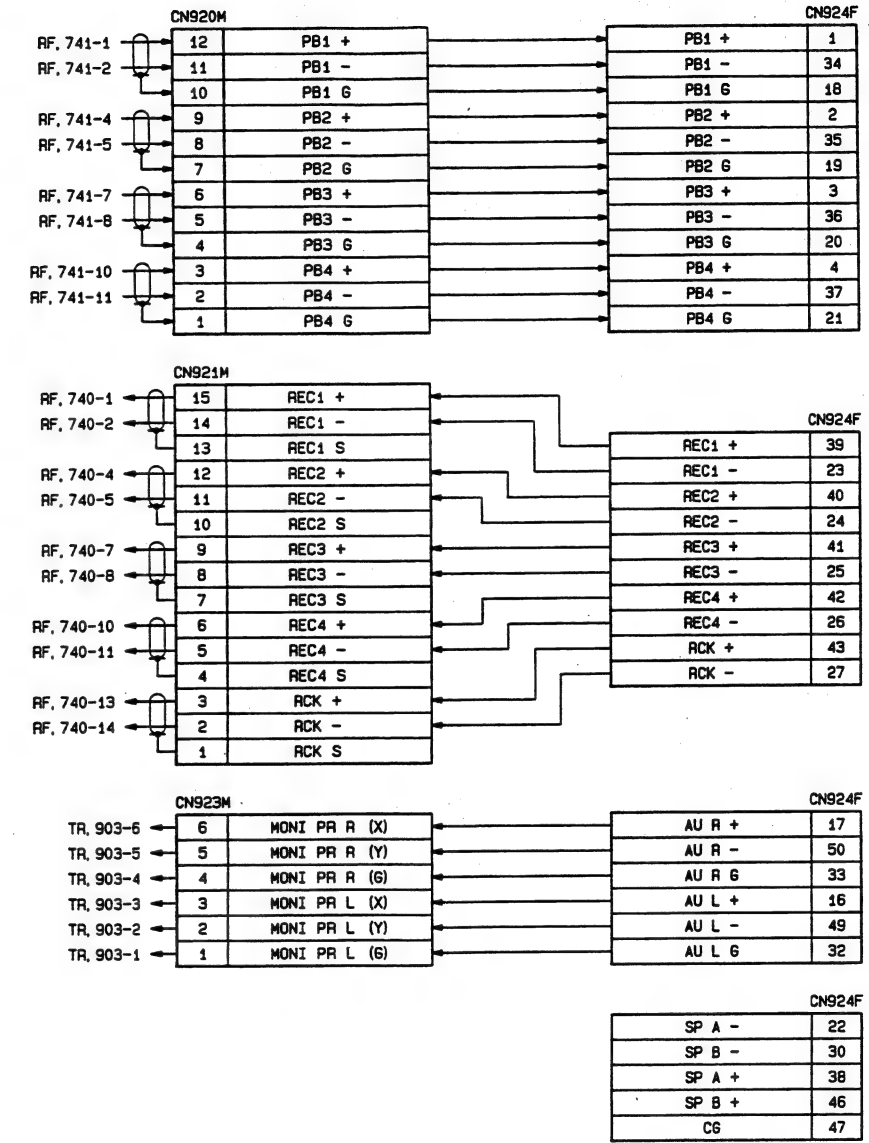
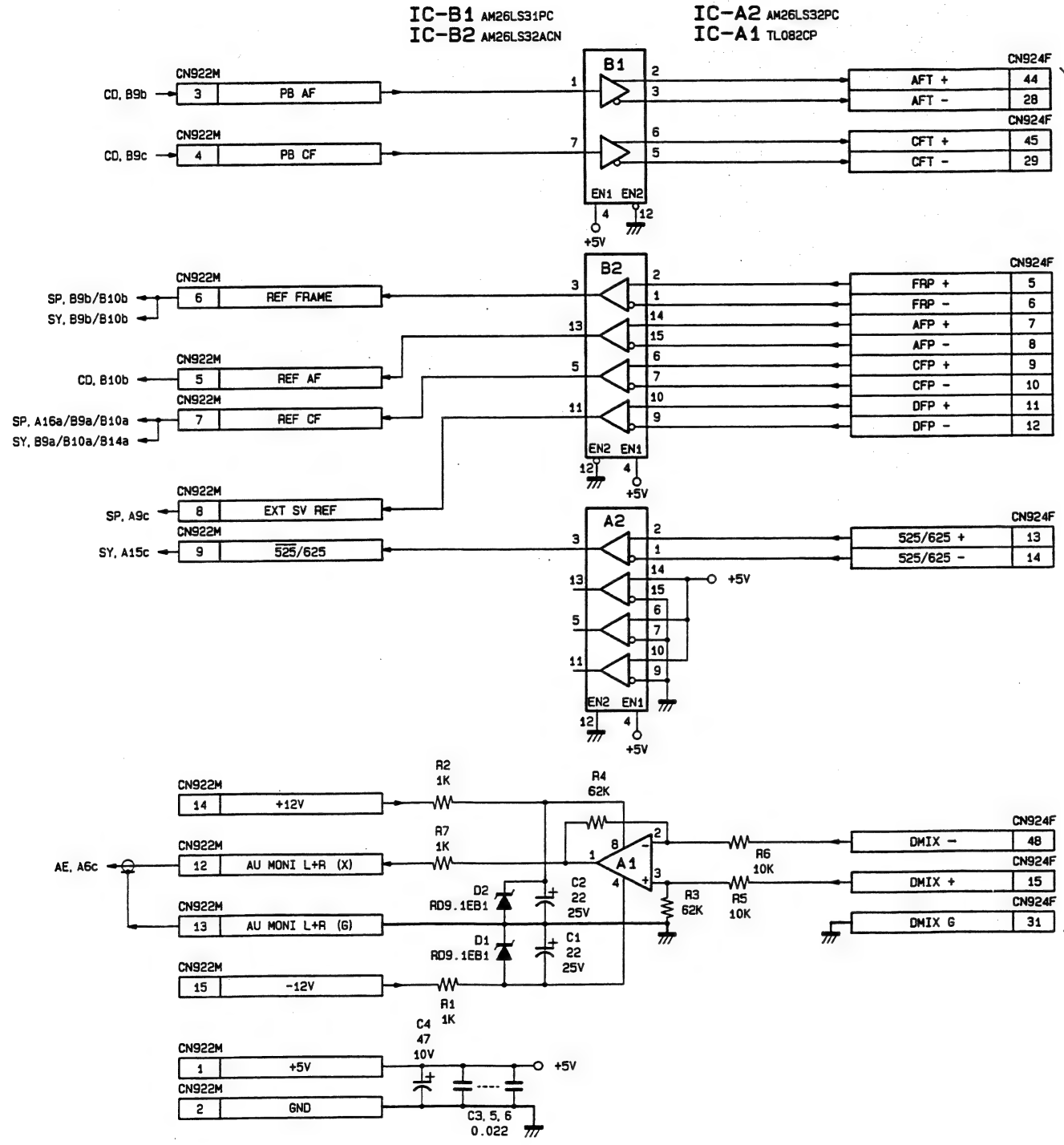

PR-87 BOARD
BOARD NO. 1-620-906-11
DVR-1000 (J) : #10001-
DVR-1000 (U/C) : #10001-
DVR-1000 (EK) : #10001-

IF-134 BOARD (1-620-888-12, 13)
Component Side

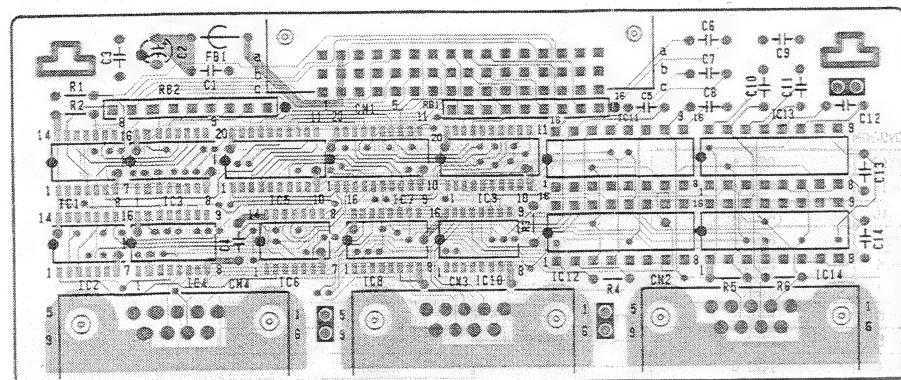

1-620-888-12,13 COMPONENT SIDE
1-620-888-12,13 SOLDER SIDE

IF-135 BOARD (1-620-889-11)
Component Side

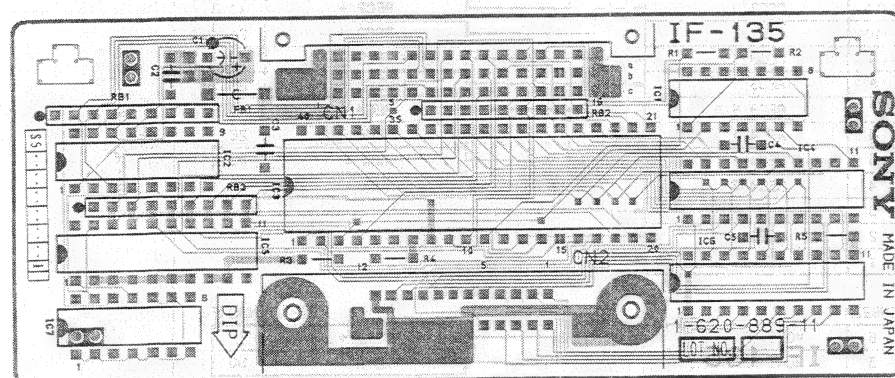

1-620-889-11 COMPONENT SIDE
1-620-889-11 SOLDER SIDE

IF-138 BOARD (1-620-890-11)
Component Side

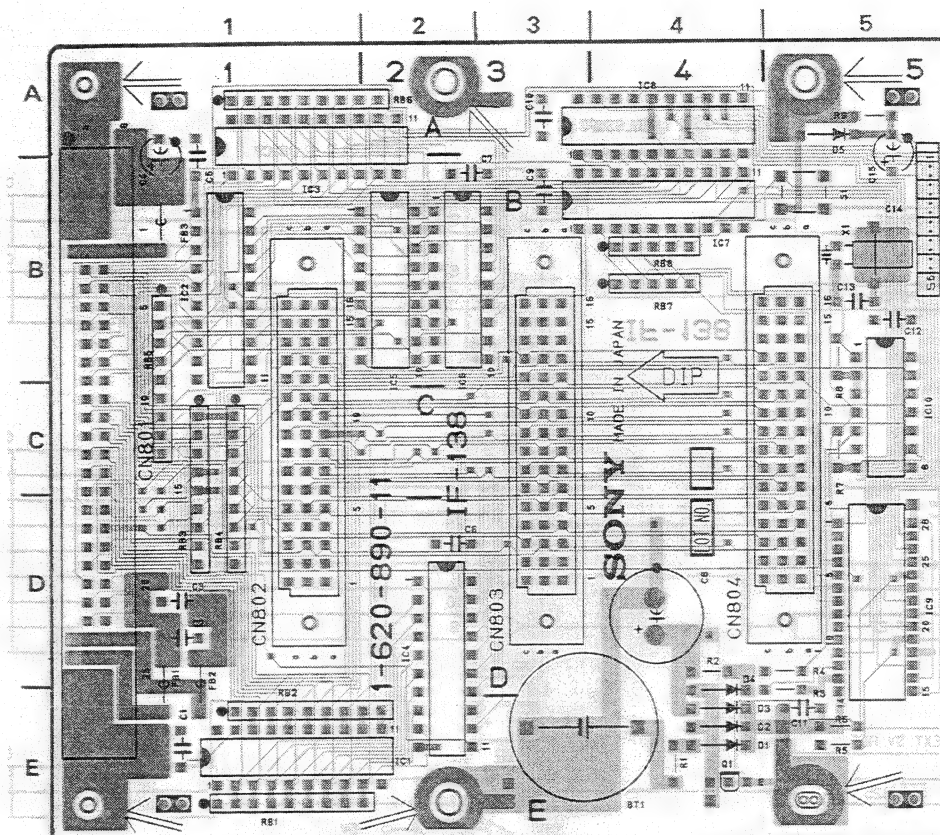

1-620-890-11 COMPONENT SIDE
1-620-890-11 SOLDER SIDE

IF-138 (1-620-890-11)

DVR-1000

| | | | |
|--------|----|-----|----|
| BT1 | E3 | Q1 | E4 |
| CN801M | B1 | RB1 | E1 |
| CN802M | D1 | RB2 | E1 |
| CN803M | D3 | RB3 | C1 |
| CN804M | D5 | RB4 | C1 |
| | | RB5 | B1 |
| D1 | E4 | RB6 | A1 |
| D2 | E4 | RB7 | B4 |
| D3 | E4 | RB8 | B4 |
| D4 | E4 | | |
| D5 | A5 | S1 | B5 |
| FB1 | D1 | X1 | B5 |
| FB2 | D1 | | |
| FB3 | B1 | | |
| IC1 | E1 | | |
| IC2 | B1 | | |
| IC3 | A1 | | |
| IC4 | D2 | | |
| IC5 | B2 | | |
| IC6 | E2 | | |
| IC7 | B4 | | |
| IC8 | A4 | | |
| IC9 | D5 | | |
| IC10 | C5 | | |

INTERFACE

IF-134, IF-135, IF-138 **INTERFACE** INTERFACE IF-134, IF-135, IF-138

IF-134 BOARD : RS-422 Interface Board
IF-135 BOARD : GP-IB Interface Board
IF-138 BOARD : Interface Mother Board

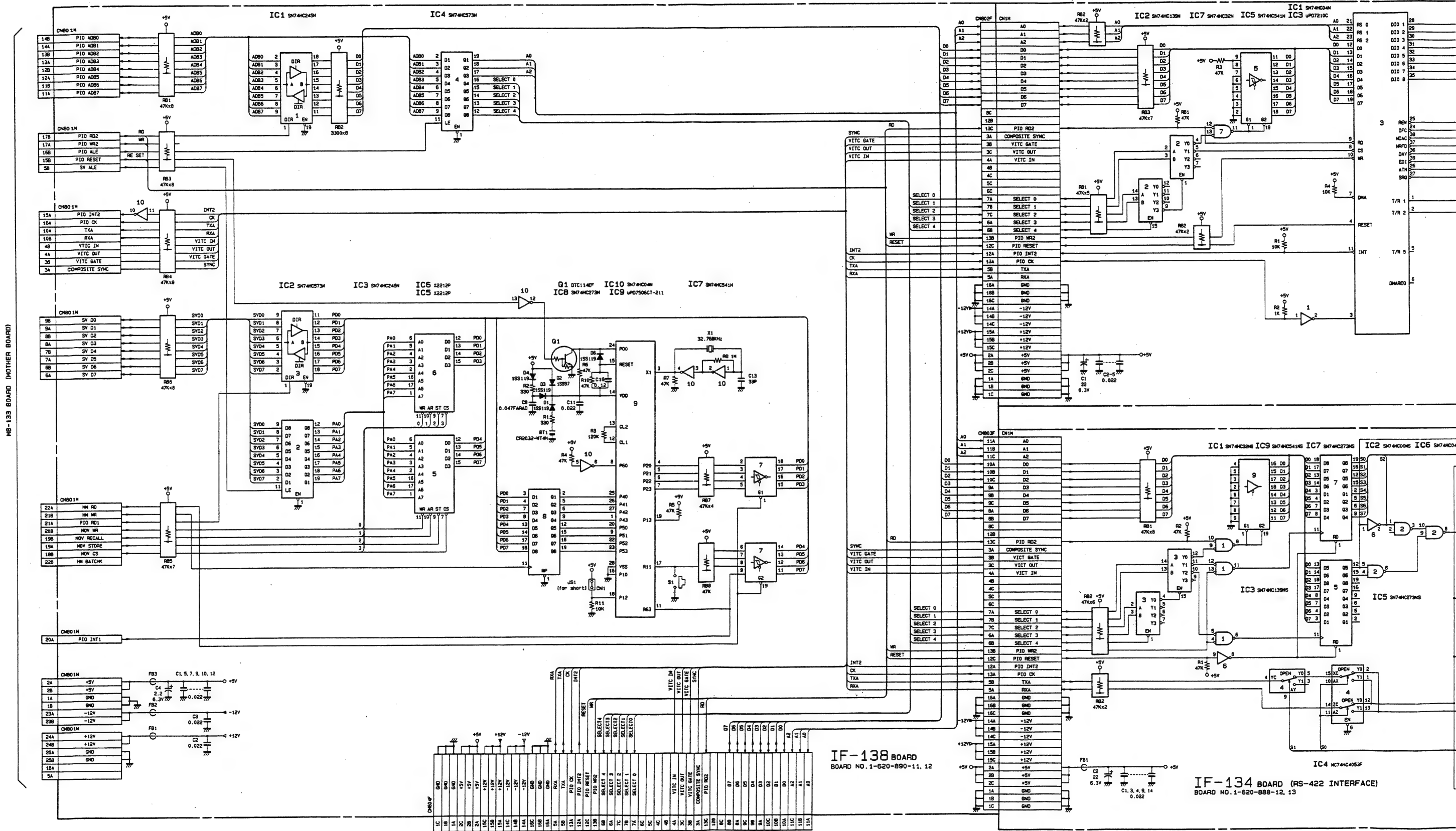

INTERFACE IF-210

IF-210 BOARD (1-624-916-11)
Component Side

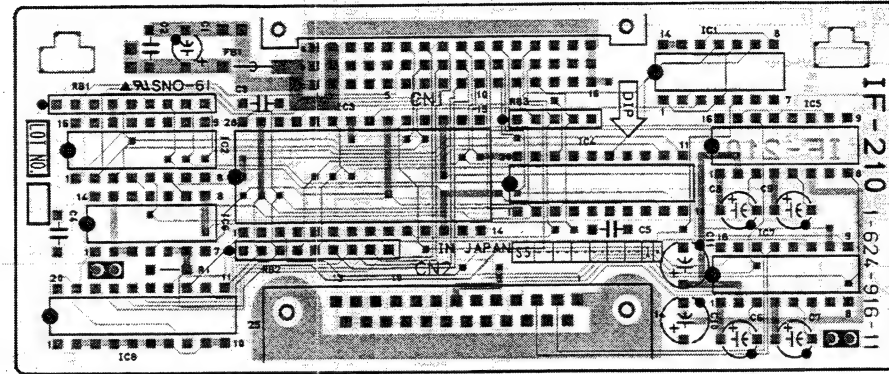

1-624-916-11 COMPONENT SIDE
1-624-916-11 SOLDER SIDE

IF-210 BOARD

| Ref. No. | Pin No. | |
|----------|---------|------------|
| | +5V | GND |
| IC 1 | 16 | 8 |
| IC 2 | 20 | 10 |
| IC 3 | 14 | 7 |
| IC 4 | 14 | 7 |
| IC 5 | 26, 58 | 10, 25, 57 |
| IC 6 | 26, 58 | 10, 25, 57 |
| IC 7 | 14 | 7 |
| IC 8 | 14 | 7 |

IF-210 BOARD
RS-232C Interface Board

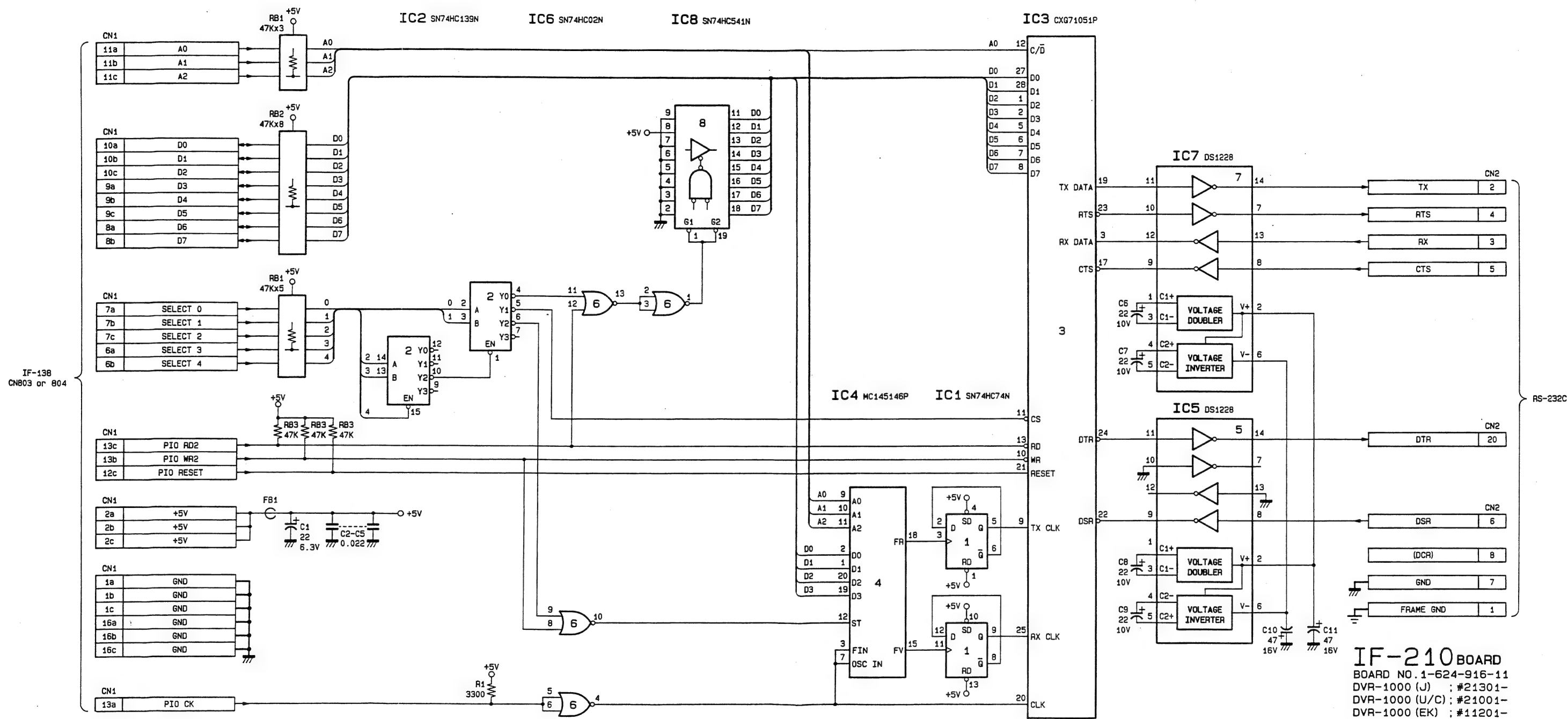

IF-221 BOARD (1-627-695-11)

Component Side

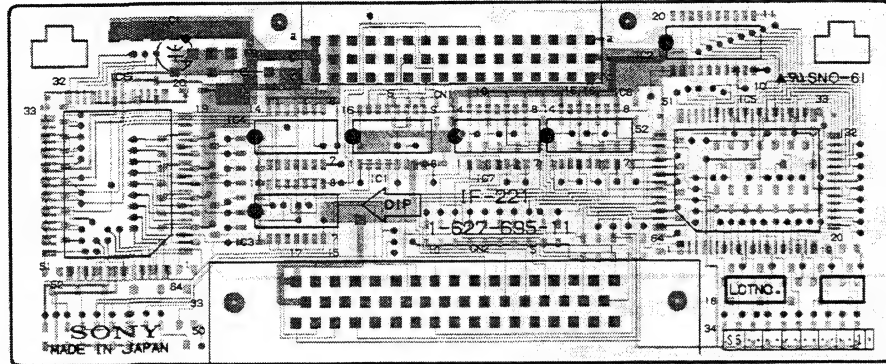

1-627-695-11 COMPONENT SIDE
1-627-695-11 SOLDER SIDE

IF-221 BOARD (1-627-695-11)

Solder Side

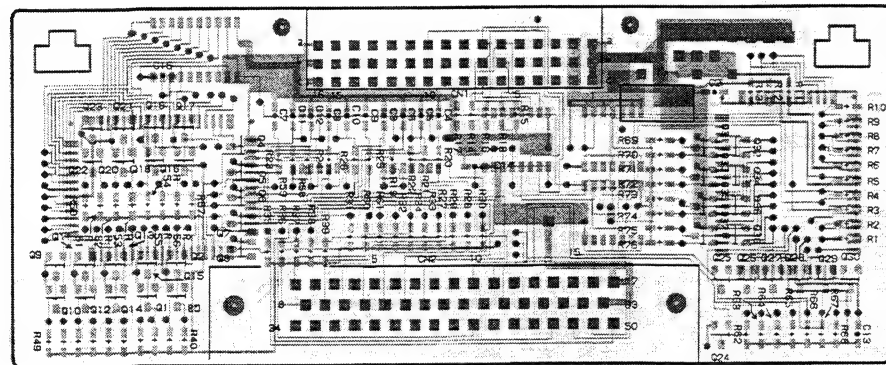

1-627-695-11 COMPONENT SIDE
1-627-695-11 SOLDER SIDE

IF-221 BOARD

| Ref. No. | Pin No. | |
|----------|---------|-----|
| | +5V | GND |
| IC 1 | 14 | 7 |
| IC 2 | 16 | 8 |
| IC 3 | 26 | 4 |
| IC 4 | 6 | 4 |
| IC 5 | 16 | 5 |
| IC 6 | 14 | 7 |
| IC 7 | 16 | 5 |
| IC 8 | 20 | 10 |

IF-221 BOARD

Parallel I/O Interface Board

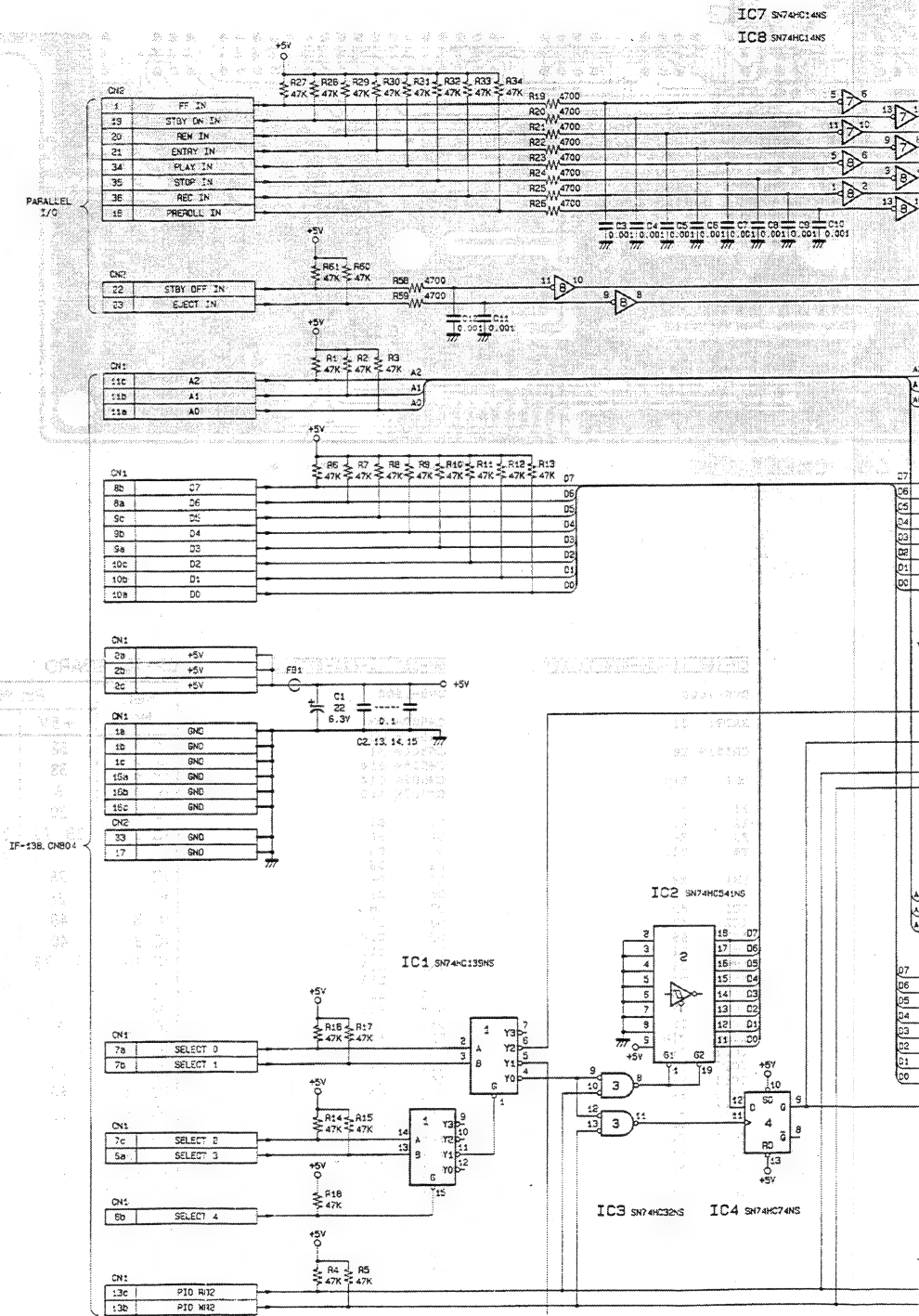

rd

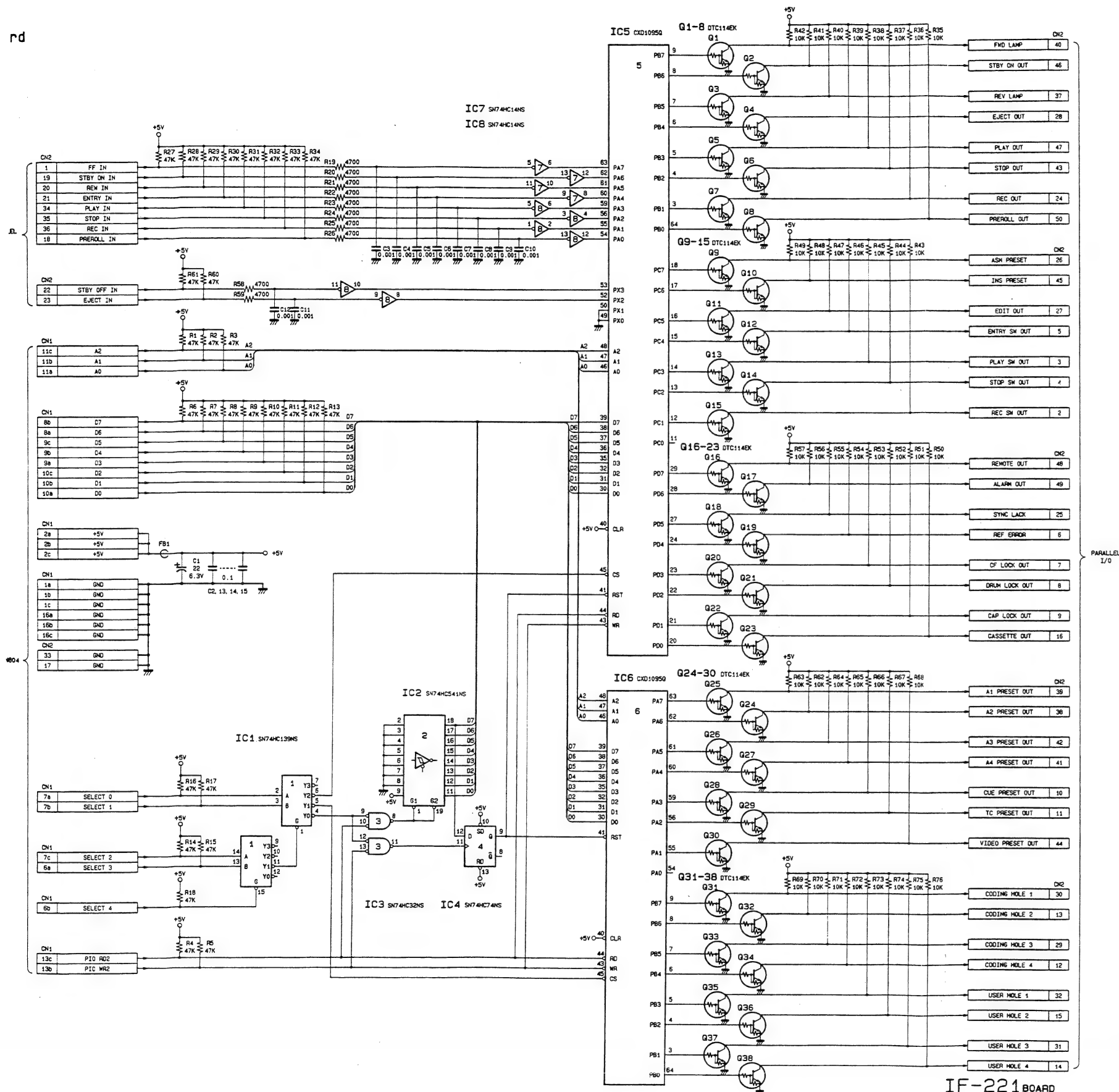

IF-221 BOARD
 BOARD NO. 1-627-695-11
 DVA-1000 (J) : #21301-
 DVA-1000 (U/C) : #21001-
 DVA-1000 (EK) : #11201-

PARALLEL I/O

CP-106, DET-3, PS-139
RE-44, SW-157, SW-158

FUNCTION CONTROL PANEL



FUNCTION CONTROL PANEL

CP-106, DE1-3, PS-139
RE-44, SW-157, SW-158

CP-106 BOARD (1-620-876-12)
Component Side

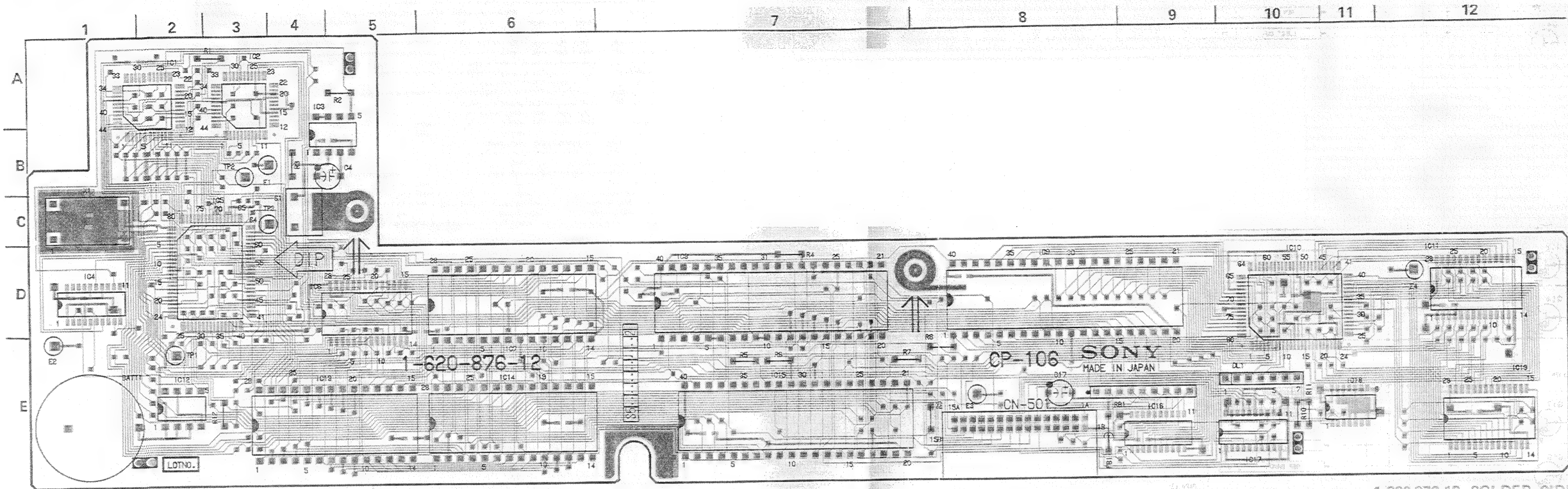

1-620-876-12 COMPONENT SIDE

1-620-876-12 SOLDER SIDE

SW-157 BOARD (1-620-877-12)
Component Side

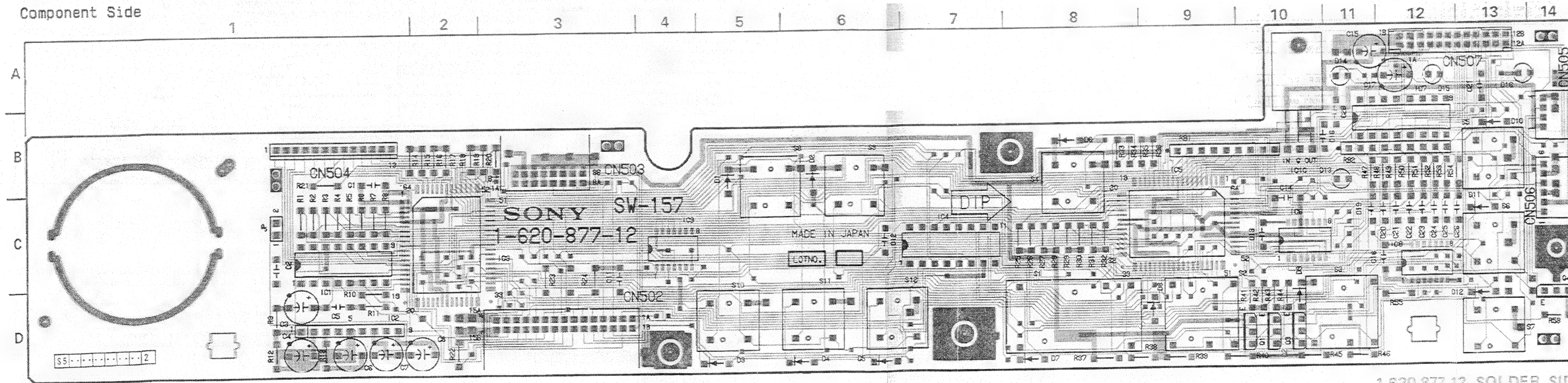

1-620-877-12 COMPONENT SIDE

1-620-877-12 SOLDER SIDE

SW-158 BOARD (1-620-878-11)
Component Side

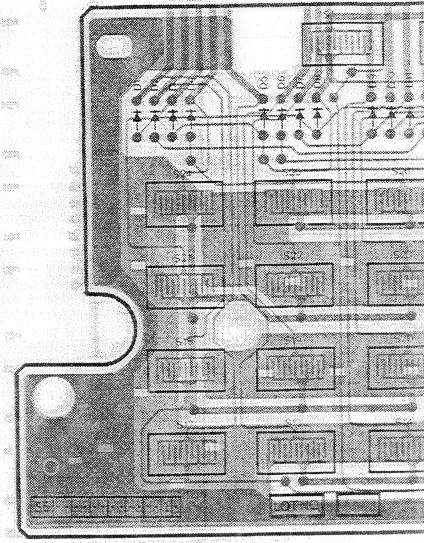

1-620-878-11 COMPONENT SIDE

| | |
|----------|-----|
| CP-106 | 1-6 |
| DVR-1000 | |
| BATT1 | E1 |
| CN501M | E8 |
| DL1 | E10 |
| E1 | E3 |
| E2 | E1 |
| E3 | E8 |
| E4 | D12 |
| FB1 | E8 |
| IC1 | A2 |
| IC2 | A3 |
| IC3 | B5 |
| IC4 | D1 |
| IC5 | D3 |
| IC6 | D5 |
| IC7 | D6 |
| IC8 | D7 |
| IC9 | D8 |
| IC10 | D10 |
| IC11 | D10 |
| IC12 | E2 |
| IC13 | E5 |
| IC14 | E6 |
| IC15 | E7 |
| IC16 | E9 |
| IC17 | E10 |
| IC18 | E11 |
| IC19 | E12 |
| RB1 | E9 |
| S1 | C4 |
| TP1 | E2 |
| TP2 | B3 |
| TP3 | C3 |
| X1 | C1 |

D (1-620-878-11)

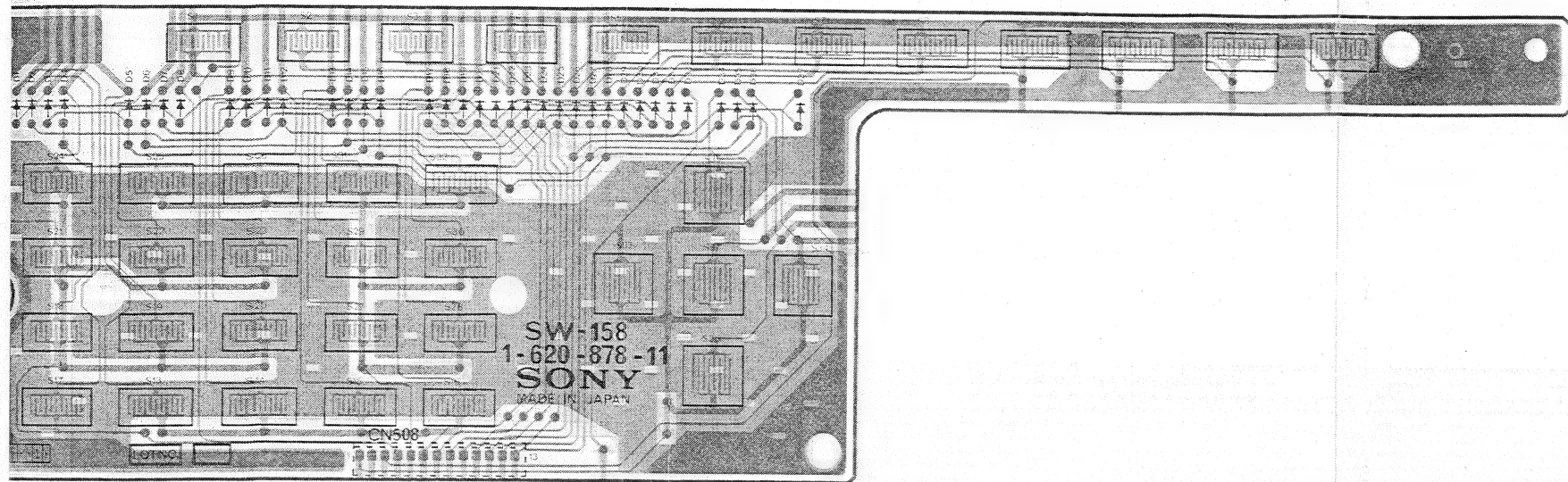

1-620-878-11 COMPONENT SIDE

1-620-878-11 SOLDER SIDE

DET-3 BOARD (1-618-489-11)

Component Side

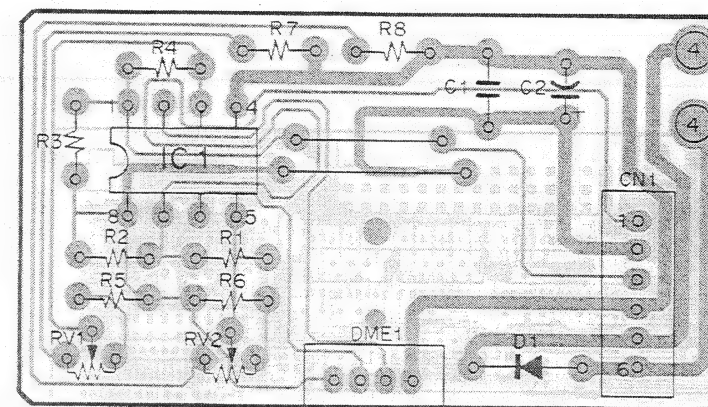

1-618-489-11 SOLDER SIDE

RE-44 BOARD (1-623-118-13)

Component Side

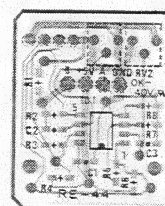

1-598-253-13 COMPONENT SIDE

1-598-253-13 SOLDER SIDE

PS-139 BOARD (1-620-879-13)

Component Side

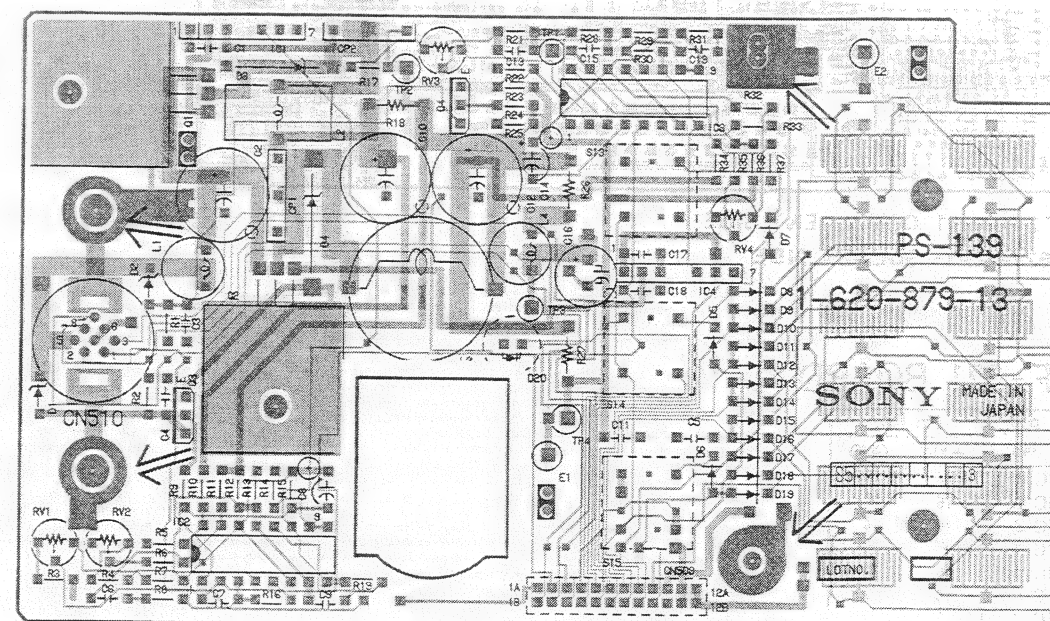

1-620-879-13 COMPONENT SIDE

1-620-879-13 SOLDER SIDE

CP-106 (1-620-876-11,12)

DVR-1000

| | |
|--------|-----|
| BATT1 | E1 |
| CN501M | E8 |
| DL1 | E10 |
| E1 | E3 |
| E2 | E1 |
| E3 | E8 |
| E4 | D12 |
| FB1 | E8 |
| IC1 | A2 |
| IC2 | A3 |
| IC3 | B5 |
| IC4 | D1 |
| IC5 | D3 |
| IC6 | D5 |
| IC7 | D6 |
| IC8 | D7 |
| IC9 | D8 |
| IC10 | D10 |
| IC11 | D12 |
| IC12 | E2 |
| IC13 | E5 |
| IC14 | E6 |
| IC15 | E7 |
| IC16 | E9 |
| IC17 | E10 |
| IC18 | E11 |
| IC19 | E12 |
| RB1 | E9 |
| S1 | C4 |
| TF1 | E2 |
| TF2 | E3 |
| TF3 | C3 |
| X1 | C1 |

SW-157 (1-620-877-12)

DVR-1000

| | |
|--------|-----|
| CN502M | D3 |
| CN503M | B3 |
| CN504M | B1 |
| CN505M | B14 |
| CN506M | C14 |
| CN507M | A12 |
| D1 | B5 |
| D2 | B6 |
| D3 | D5 |
| D4 | D6 |
| D5 | D6 |
| D6 | B8 |
| D7 | D8 |
| D8 | D9 |
| D9 | D10 |
| D10 | B13 |
| D11 | C13 |
| D12 | D13 |
| D13 | B11 |
| D14 | A11 |
| D15 | A12 |
| D16 | A13 |
| IC1 | C1 |
| IC2 | D1 |
| IC3 | C2 |
| IC4 | C7 |
| IC5 | C9 |
| IC6 | C10 |
| IC7 | B12 |
| IC8 | C12 |
| IC9 | C4 |
| IC10 | A10 |
| Q1 | D10 |
| Q2 | D10 |
| Q3 | D10 |
| Q4 | D14 |
| RB1 | B9 |
| RB2 | B12 |
| S1 | D8 |
| S2 | D9 |
| S3 | D11 |
| S4 | B8 |
| S5 | B13 |
| S6 | C13 |
| S7 | D13 |
| S8 | B5 |
| S9 | B6 |
| S10 | D5 |
| S11 | D6 |
| S12 | D6 |

CP-106 BOARD

| Ref. No. | Pin No. | |
|----------|---------|-----------------------|
| | +5V | GND |
| IC 1 | 38 | 16 |
| IC 2 | 38 | 16 |
| IC 3 | 8 | 4 |
| IC 4 | 20 | 10 |
| IC 5 | 33, 73 | 2, 12, 23, 42, 52, 63 |
| IC 6 | 28 | 14 |
| IC 7 | 28 | 14 |
| IC 8 | 40 | 20 |
| IC 9 | 40 | 20 |
| IC 10 | 33, 73 | 2, 12, 23, 42, 52, 63 |
| IC 11 | 28 | 14 |
| IC 12 | 8 | 4 |
| IC 13 | 28 | 14 |
| IC 14 | 28 | 14 |
| IC 15 | 40 | 20 |
| IC 16 | 20 | 10 |
| IC 17 | 20 | 10 |
| IC 18 | 14 | 7 |
| IC 19 | 28 | 14 |

SW-157 BOARD

| Ref. No. | Pin No. | |
|----------|---------|----------------|
| | +5V | GND |
| IC 1 | 16 | 8 |
| IC 2 | 9 | 5, 6 |
| IC 3 | 26, 58 | 10, 27, 42, 57 |
| IC 4 | 16 | 8 |
| IC 5 | 26, 58 | 10, 27, 42, 57 |
| IC 6 | 14 | 7 |
| IC 7 | 16 | 8 |
| IC 8 | 14 | 7 |
| IC 9 | 14 | 7 |

PS-139 BOARD

| Ref. No. | Pin No. | |
|----------|---------|-----|
| | +22V | GND |
| IC 1 | 1 | 3 |
| IC 2 | 12 | 7 |
| IC 3 | 12 | 7 |
| IC 4 | 1 | 3 |

FUNCTION CONTROL PANEL

CP-106 BOARD
Function Control Panel

DET-3 BOARD

Search Dial Detector

PS-139 BOARD

Power Supply Relaying

RE-44 BOARD

Rotary Encoder Detector

SW-157 BOARD

Switch

SW-158 BOARD

Switch

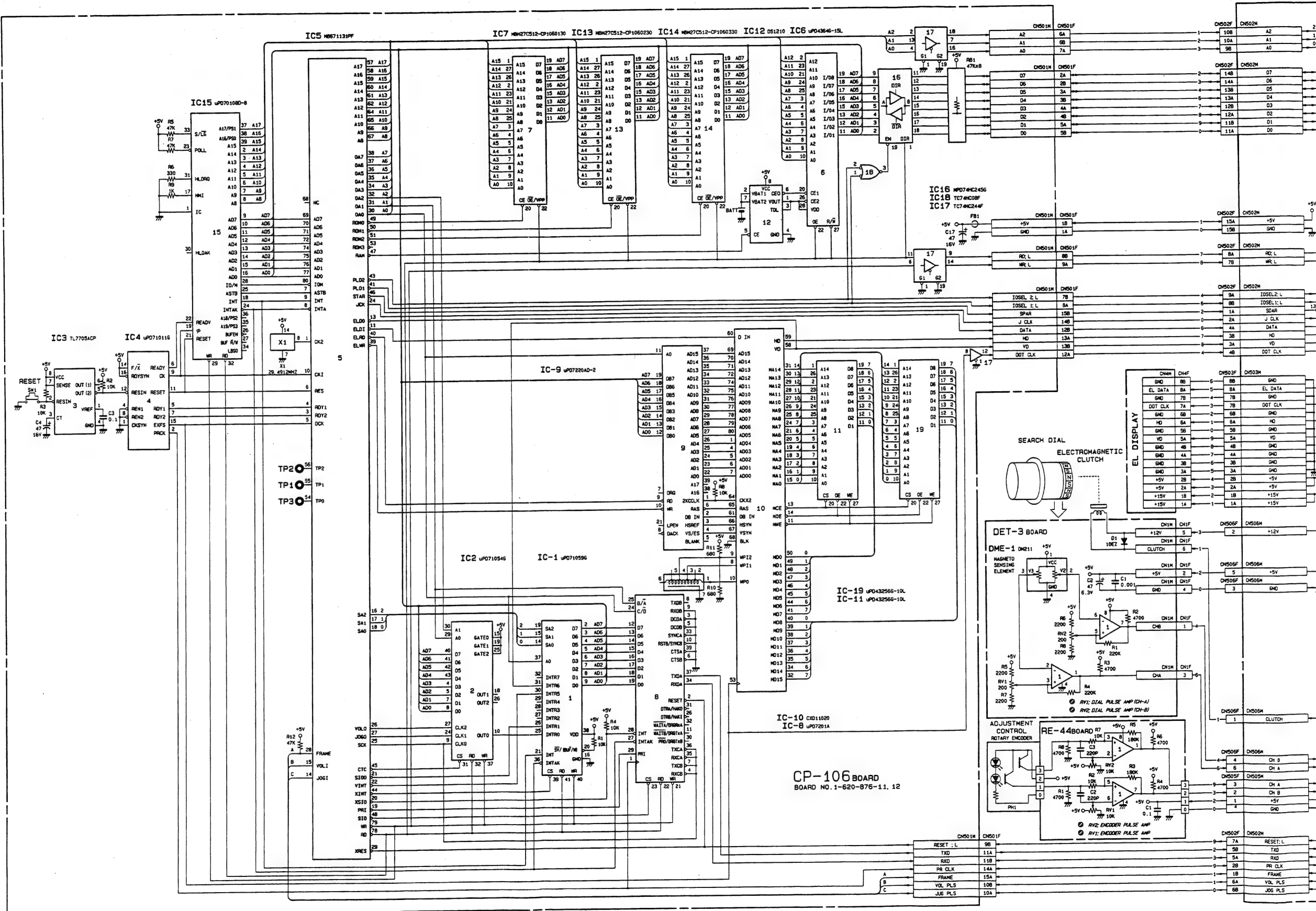

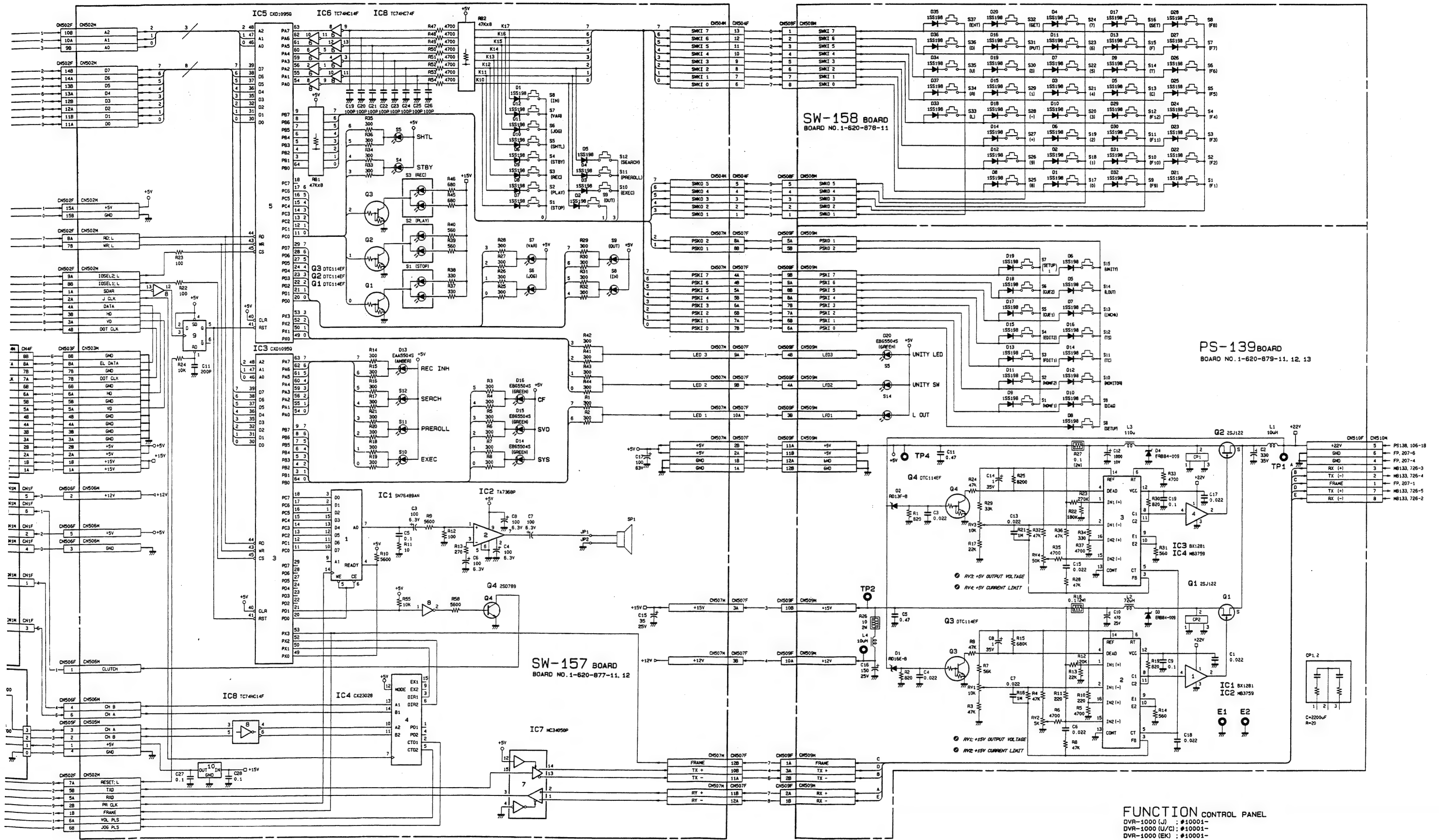



PD-36 BOARD (1-620-902-11)
Component Side

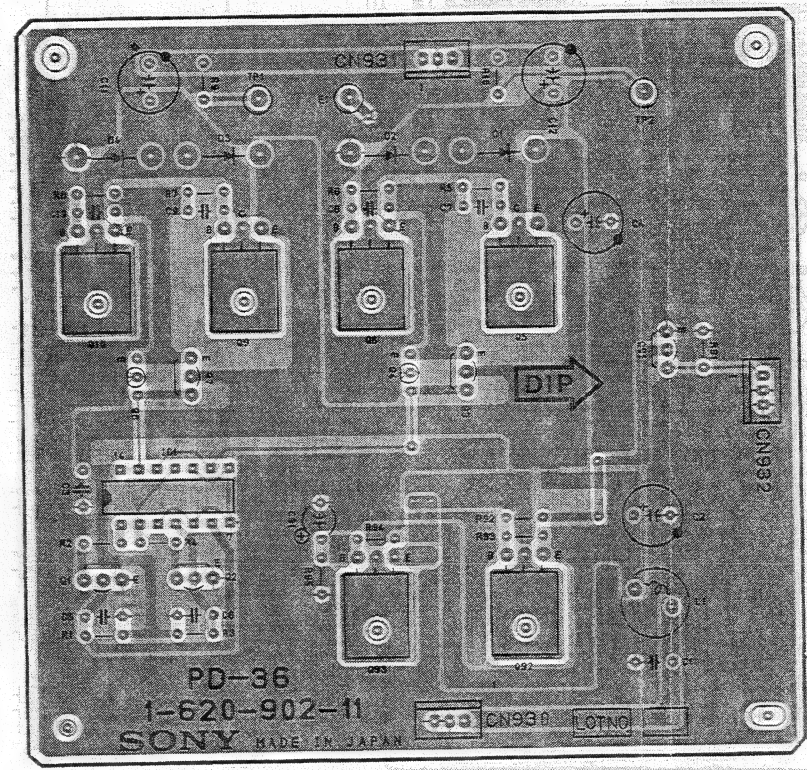

1-620-902-11 COMPONENT SIDE
1-620-902-11 SOLDER SIDE

MD-43 BOARD (1-620-881-12)
Component Side

MD-43, PD-36 BOARD

MD-43, PD-36 BOARD

FUNCTION CONTROL PANEL

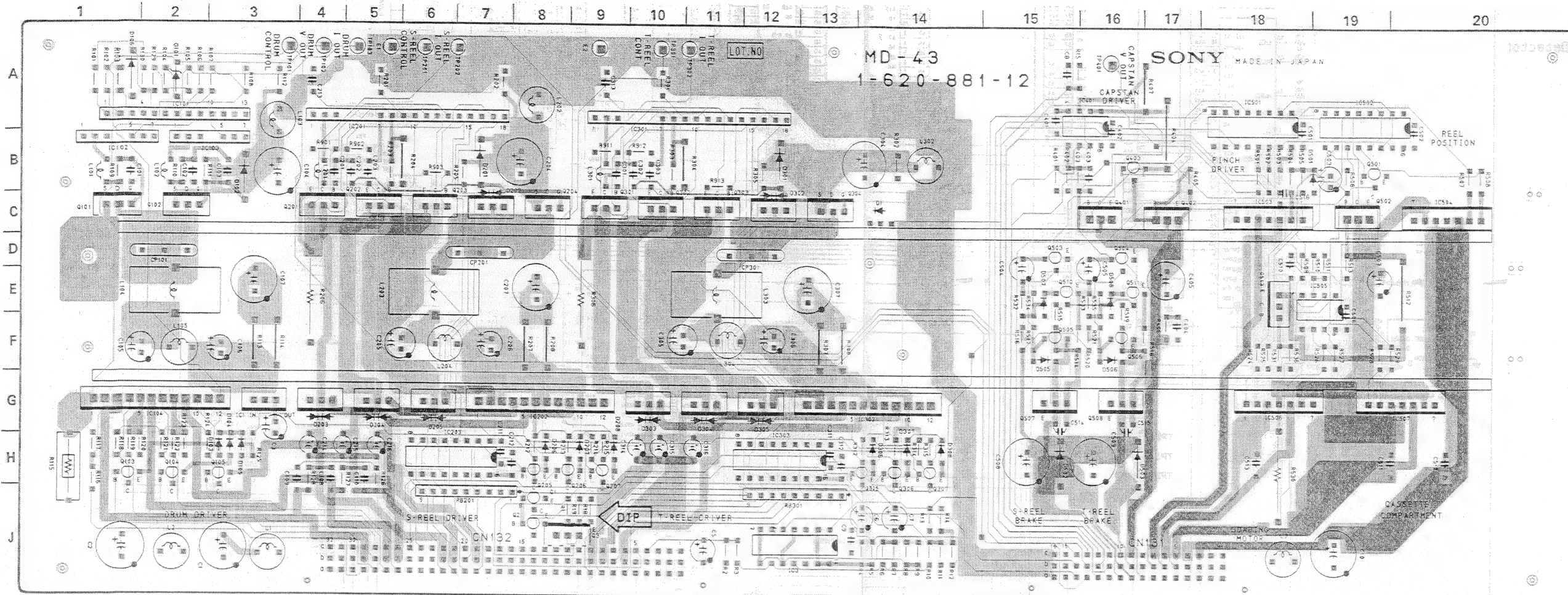

MD-43 (1-620-881-12)

| | | |
|----------|-----|-------|
| DVR-1000 | | |
| CN131M | J16 | Q1 |
| CN132M | J7 | Q2 |
| | | Q3 |
| CP101 | D2 | Q101 |
| CP201 | D7 | Q102 |
| CP301 | D12 | Q103 |
| | | Q104 |
| | | Q105 |
| D1 | C14 | H2 |
| D101 | A2 | H3 |
| D102 | E3 | H4 |
| D103 | H3 | H5 |
| D104 | H2 | H6 |
| D105 | H3 | H7 |
| D106 | A1 | H8 |
| D201 | B7 | H9 |
| D202 | B7 | H10 |
| D203 | G4 | H11 |
| D204 | G5 | H12 |
| D205 | G6 | H13 |
| D206 | H8 | H14 |
| D207 | H9 | H15 |
| D208 | H9 | H16 |
| D301 | H12 | H17 |
| D302 | C12 | H18 |
| D303 | G10 | H19 |
| D304 | G11 | H20 |
| D305 | G12 | H21 |
| D306 | H14 | H22 |
| D307 | H14 | H23 |
| D308 | H14 | H24 |
| D501 | B18 | H25 |
| D502 | H15 | H26 |
| D503 | H16 | H27 |
| D505 | F15 | H28 |
| D506 | F16 | H29 |
| D507 | E15 | H30 |
| D508 | E16 | H31 |
| E1 | A5 | J7 |
| E2 | A9 | J12 |
| IC1 | G3 | TP101 |
| IC3 | J12 | TP102 |
| IC101 | A2 | TP103 |
| IC102 | B1 | TP201 |
| IC103 | B2 | TP202 |
| IC104 | G2 | TP301 |
| IC201 | A5 | TP302 |
| IC202 | G8 | TP401 |
| IC203 | H6 | |
| IC301 | A10 | |
| IC302 | G14 | |
| IC303 | H12 | |
| IC401 | A16 | |
| IC501 | A18 | |
| IC502 | A19 | |
| IC503 | C18 | |
| IC504 | C20 | |
| IC505 | E19 | |
| IC506 | G18 | |
| IC507 | G20 | |

1-620-881-12 COMPONENT SIDE

1-620-881-12 SOLDER SIDE

MD-43 BOARD
Motor Driver

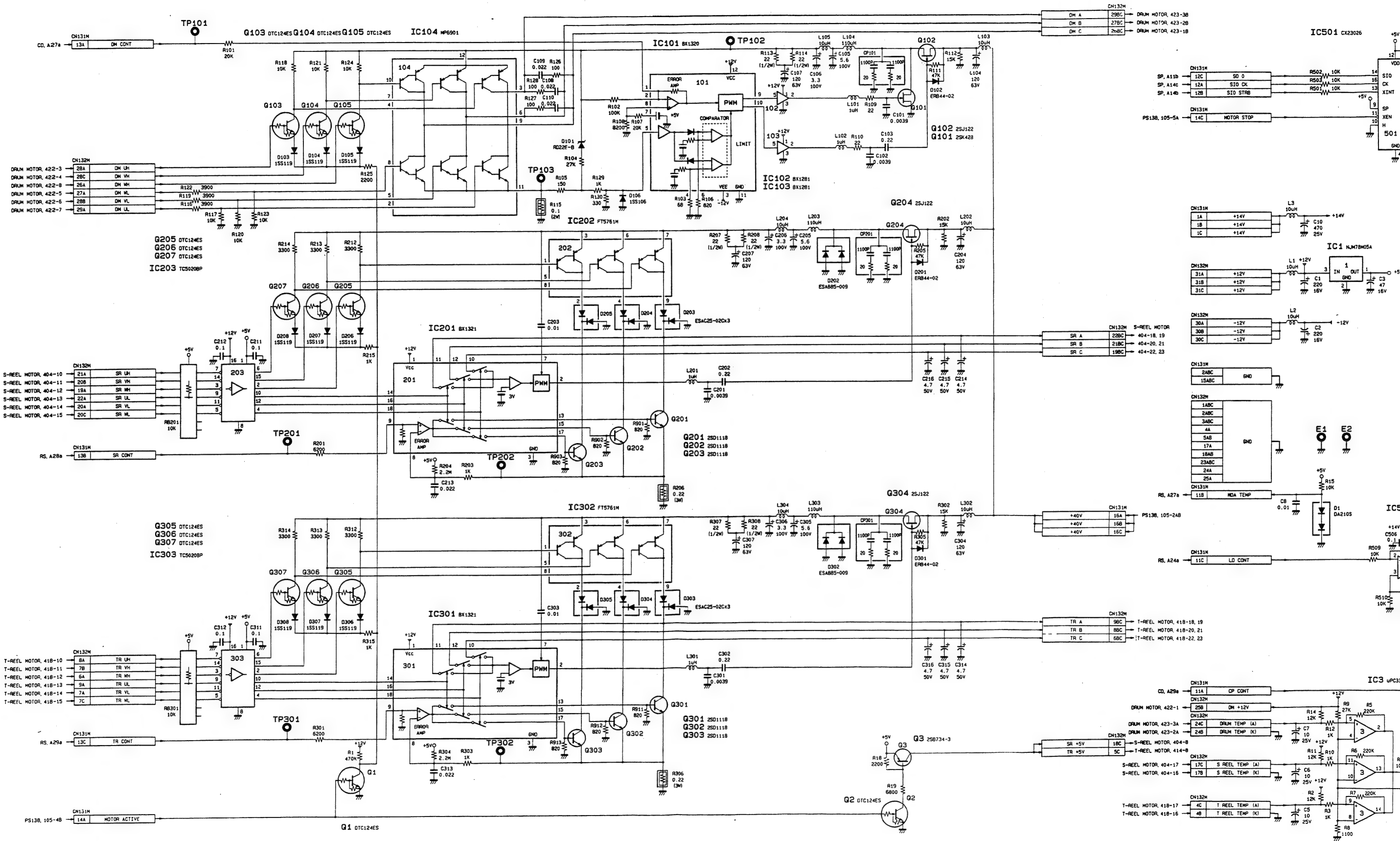



PD-36 BOARD

Power Rotary Trans Driver

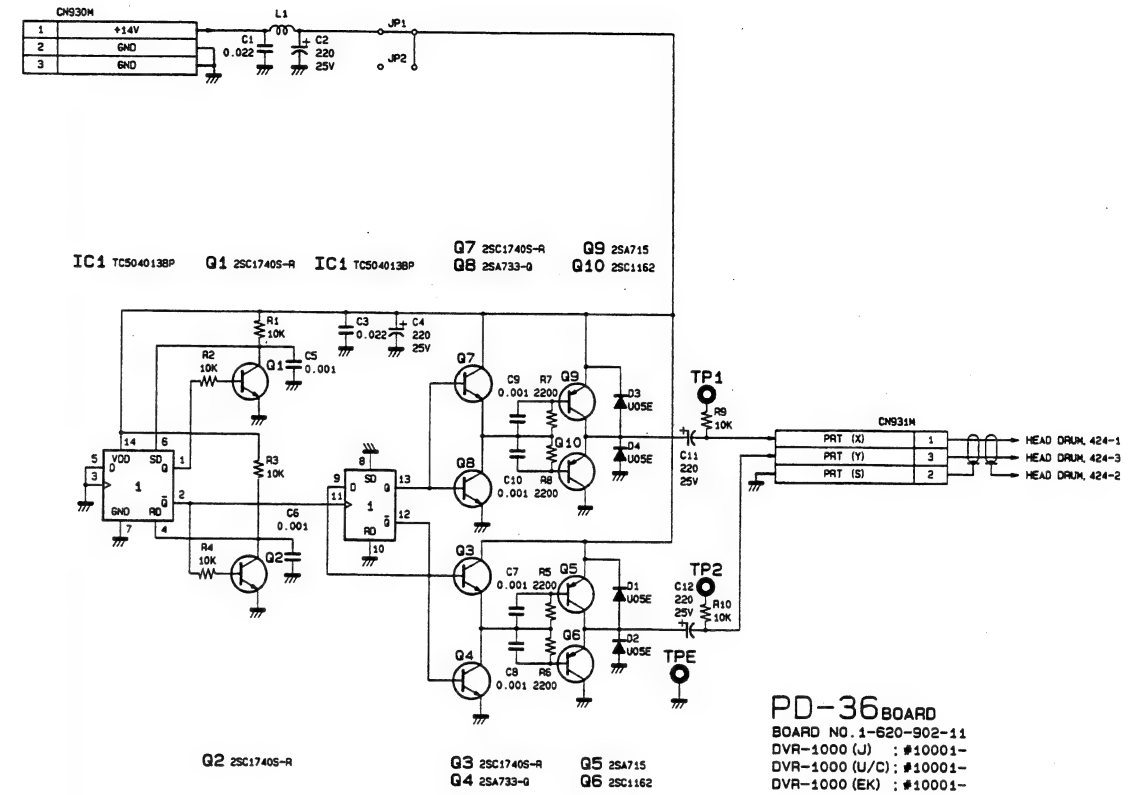

PD-36 BOARD
 BOARD NO. 1-620-902-11
 DVR-1000 (J) : #10001-
 DVR-1000 (U/C) : #10001-
 DVR-1000 (EK) : #10001-

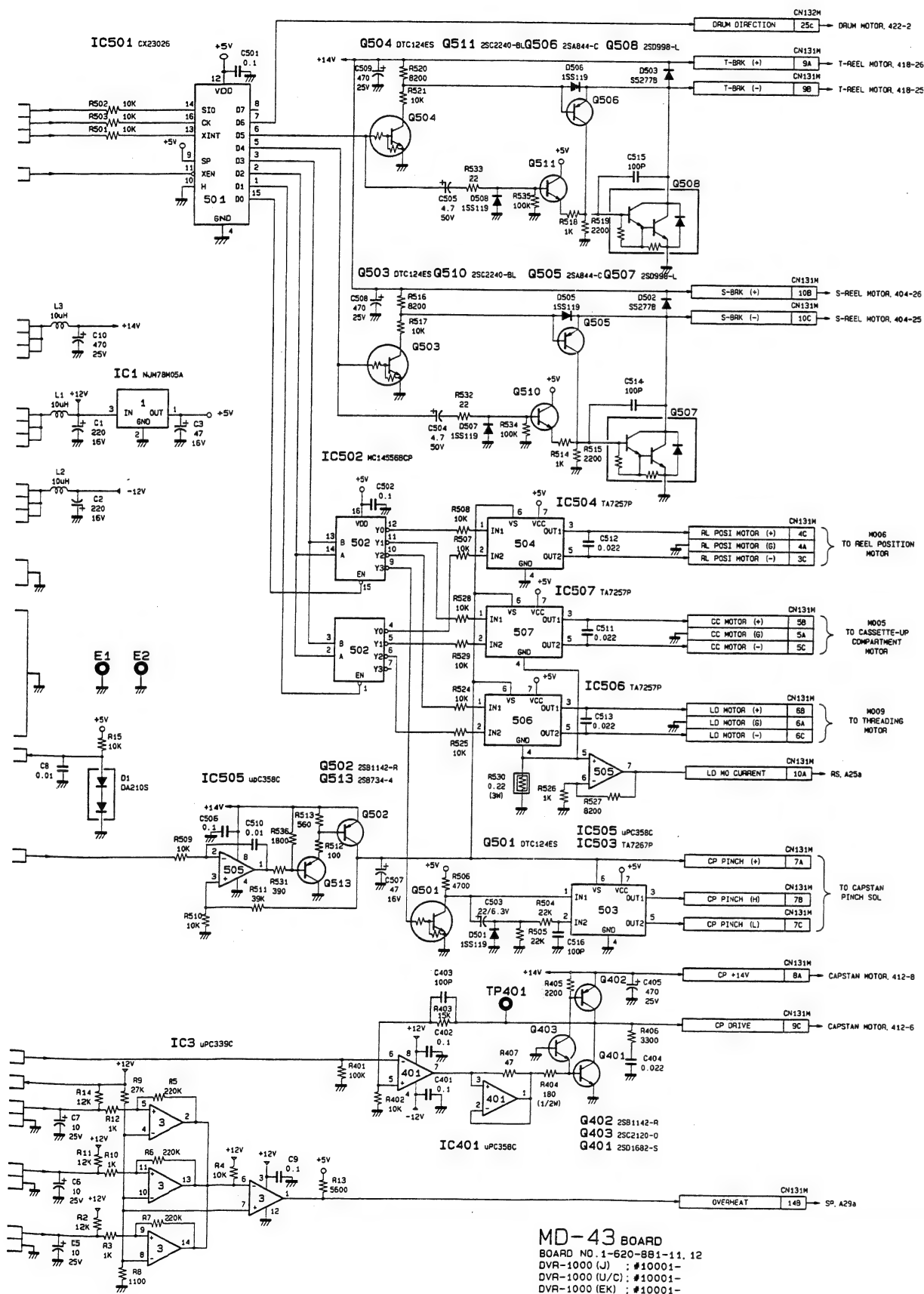

MD-43 BOARD
 BOARD NO. 1-620-881-11, 12
 DVR-1000 (J) : #10001-
 DVR-1000 (U/C) : #10001-
 DVR-1000 (EK) : #10001-

MD-43 BOARD

| Ref. No. | Pin No. | | | | |
|----------|-----------------------------|------|-----|-----|------|
| | +14V | +12V | +5V | GND | -12V |
| IC 1 | Refer to schematic diagram. | | | | |
| IC 3 | 3 | | 12 | | |
| IC 101 | 12 | | 11 | | 3 |
| IC 102 | 1 | | 3 | | |
| IC 103 | 1 | | 3 | | |
| IC 104 | Refer to schematic diagram. | | | | |
| IC 201 | 1 | | 3 | | |
| IC 202 | Refer to schematic diagram. | | | | |
| IC 203 | 16 | 1 | 8 | | |
| IC 301 | 1 | | 3 | | |
| IC 302 | Refer to schematic diagram. | | | | |
| IC 303 | 16 | 1 | 8 | | |
| IC 401 | 8 | | | | 4 |
| IC 501 | | | 12 | | 4 |
| IC 502 | | | 16 | | 8 |
| IC 503 | | | 7 | | 4 |
| IC 504 | | | 7 | | 4 |
| IC 505 | | | 7 | | 4 |
| IC 506 | | | 7 | | 4 |
| IC 507 | | | 7 | | 4 |

RE-32 BOARD (1-620-882-12)
Component Side

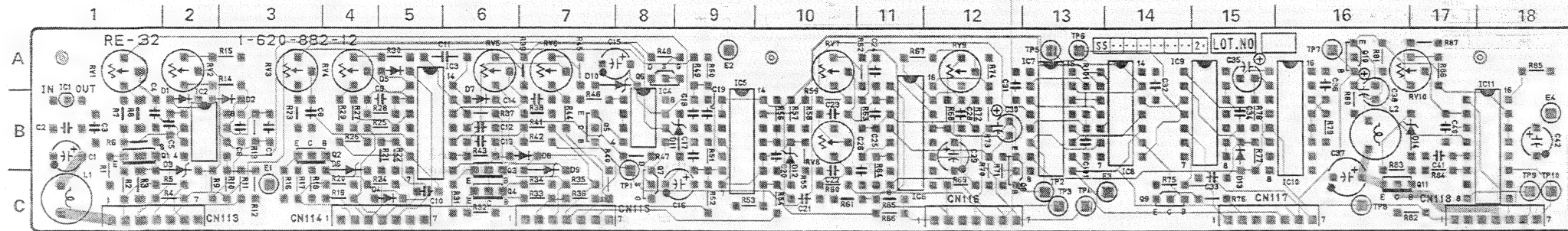

1-620-882-12 COMPONENT SIDE

1-620-882-12 SOLDER SIDE

CT-74 BOARD (1-620-883-11)
Component Side

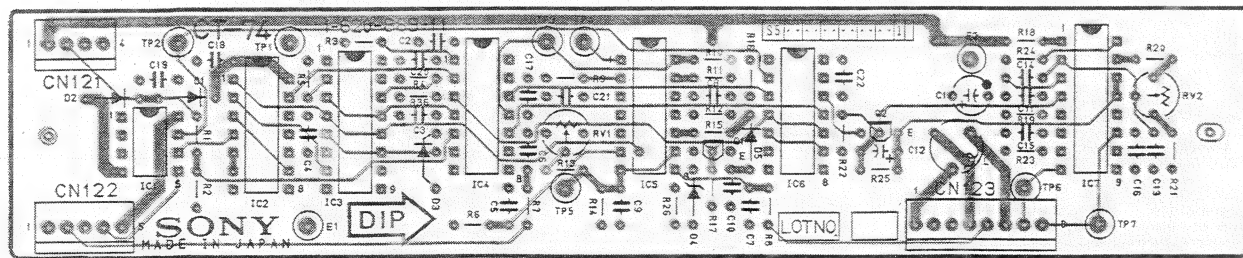

1-620-883-11 COMPONENT SIDE

1-620-883-11 SOLDER SIDE

RE-32 (1-620-882-12)

DVR-1000

| | | | |
|--------|-----|------|-----|
| CN113P | C1 | RV5 | A6 |
| CN114F | C5 | RV6 | A7 |
| CN115F | C7 | RV7 | A10 |
| CN116F | C12 | RV8 | B10 |
| CN117F | C15 | RV9 | A12 |
| CN118F | C18 | RV10 | A16 |

| | | | |
|-----|-----|------|-----|
| D1 | B2 | TP1 | B8 |
| D2 | B3 | TP2 | B3 |
| D3 | B2 | TP3 | C13 |
| D4 | C5 | TP4 | C13 |
| D5 | A5 | TP5 | A13 |
| D6 | B4 | TP6 | A13 |
| D7 | B6 | TP7 | A16 |
| D8 | B7 | TP8 | C16 |
| D9 | B7 | TP9 | C18 |
| D10 | A8 | TP10 | C18 |
| D11 | B8 | | |
| D12 | B10 | | |
| D13 | B15 | | |
| D14 | B16 | | |

| | | | |
|------|-----|--|--|
| B1 | C3 | | |
| E2 | A9 | | |
| E3 | C13 | | |
| E4 | B18 | | |
| IC1 | B1 | | |
| IC2 | B2 | | |
| IC3 | B5 | | |
| IC4 | B8 | | |
| IC5 | B9 | | |
| IC6 | B11 | | |
| IC7 | B13 | | |
| IC8 | B14 | | |
| IC9 | B15 | | |
| IC10 | B16 | | |
| IC11 | B18 | | |

| | | | |
|-----|-----|--|--|
| Q1 | B1 | | |
| Q2 | B3 | | |
| Q3 | B6 | | |
| Q4 | C6 | | |
| Q5 | B7 | | |
| Q6 | A8 | | |
| Q7 | C8 | | |
| Q8 | B12 | | |
| Q9 | C14 | | |
| Q10 | A16 | | |
| Q11 | C16 | | |
| RV1 | A1 | | |
| RV2 | A2 | | |
| RV3 | A3 | | |
| RV4 | A4 | | |

PS-138 (1-620-880-12)

DVR-1000

| | | | |
|--------|-----|-------|-----|
| CN103M | C2 | D114 | C6 |
| CN104M | C1 | D115 | C6 |
| CN105M | D1 | D116 | D7 |
| CN106M | D1 | | |
| CN107M | A14 | F1 | A5 |
| CN108M | A14 | F2 | A3 |
| CN109M | B14 | F3 | D1 |
| CN110M | C3 | F10 | C4 |
| CN111M | G7 | F11 | B4 |
| CN112M | G12 | | |
| CN113M | A13 | IC1 | G5 |
| CN114M | A12 | IC2 | G6 |
| CN115M | A11 | IC3 | G8 |
| CN116M | A8 | IC4 | G9 |
| CN117M | A6 | IC5 | G10 |
| CN118M | A5 | IC6 | G11 |
| CN119M | C4 | IC7 | G7 |
| CN120M | G7 | IC101 | B9 |
| | | IC102 | B10 |
| | | IC103 | B12 |
| | | IC104 | B12 |
| | | IC105 | B14 |

| | | | |
|-------|-----|------|-----|
| CP1 | G12 | | |
| CP101 | E5 | Q1 | G5 |
| CP102 | E6 | Q2 | G6 |
| CP103 | E7 | Q3 | G6 |
| CP104 | E8 | Q4 | G9 |
| CP105 | E9 | Q5 | G10 |
| CP106 | E10 | Q6 | G11 |
| CP107 | E10 | Q7 | G13 |
| CP108 | E11 | Q8 | F13 |
| CP109 | E11 | Q101 | B7 |
| CP110 | E12 | Q102 | B10 |
| CP111 | E12 | Q103 | B11 |
| CP112 | E13 | Q104 | B11 |
| | | Q105 | B12 |
| | | Q106 | B13 |
| D1 | C3 | | |
| D2 | D3 | | |
| D3 | G12 | | |
| D4 | G13 | | |
| D5 | G13 | | |
| D6 | G13 | RY1 | C3 |
| D7 | G13 | | |
| D8 | G13 | T1 | G5 |
| D9 | G12 | T2 | G6 |
| D101 | E5 | T3 | G8 |
| D102 | E6 | T4 | G9 |
| D103 | E7 | T6 | G11 |
| D104 | E8 | T7 | E6 |
| D105 | E9 | T8 | E7 |
| D106 | E10 | T9 | F11 |
| D107 | E10 | T10 | E12 |
| D108 | E11 | | |
| D109 | E11 | VDR1 | B3 |
| D110 | E12 | | |
| D111 | E12 | | |
| D112 | B13 | | |
| D113 | D4 | | |

PS-138 BOARD (1-620-880-12)
Component Side

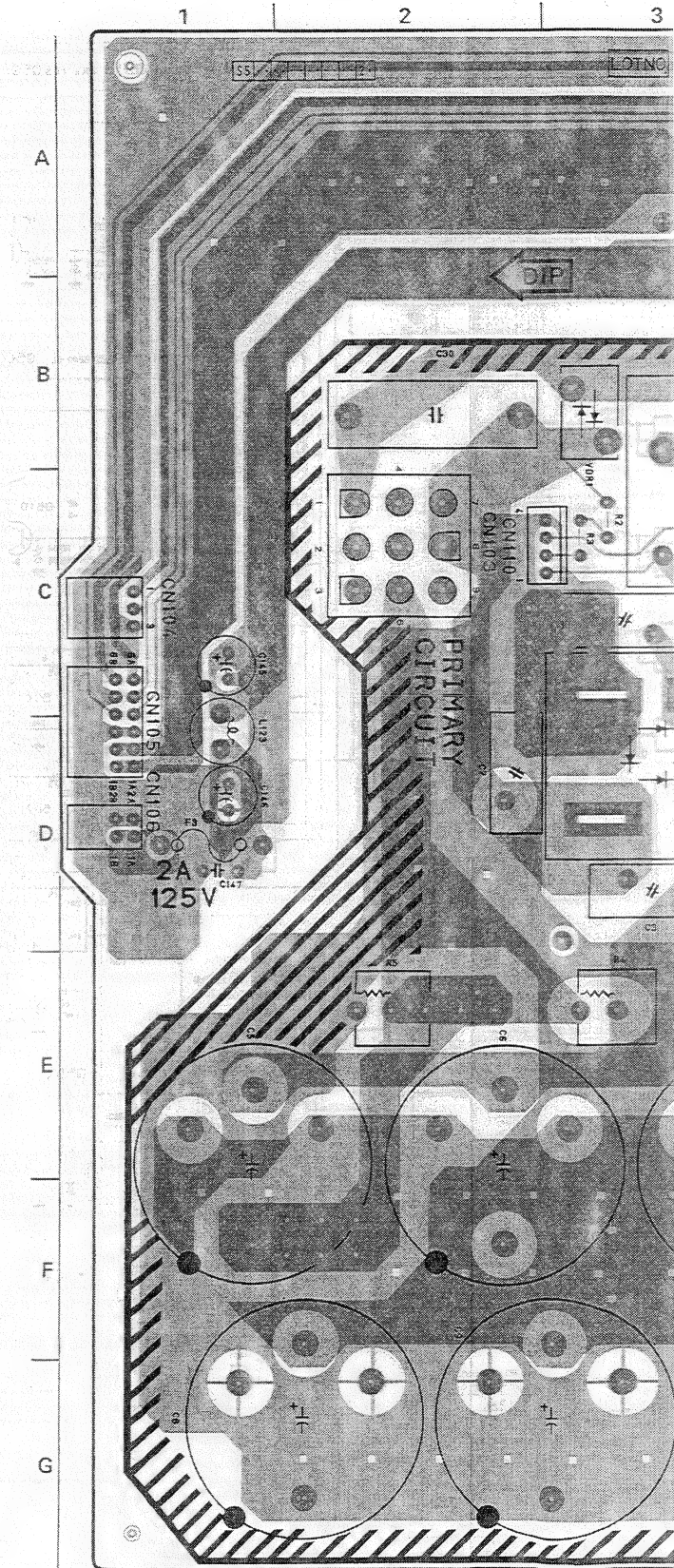

1-620-880-12 COMPONENT SIDE

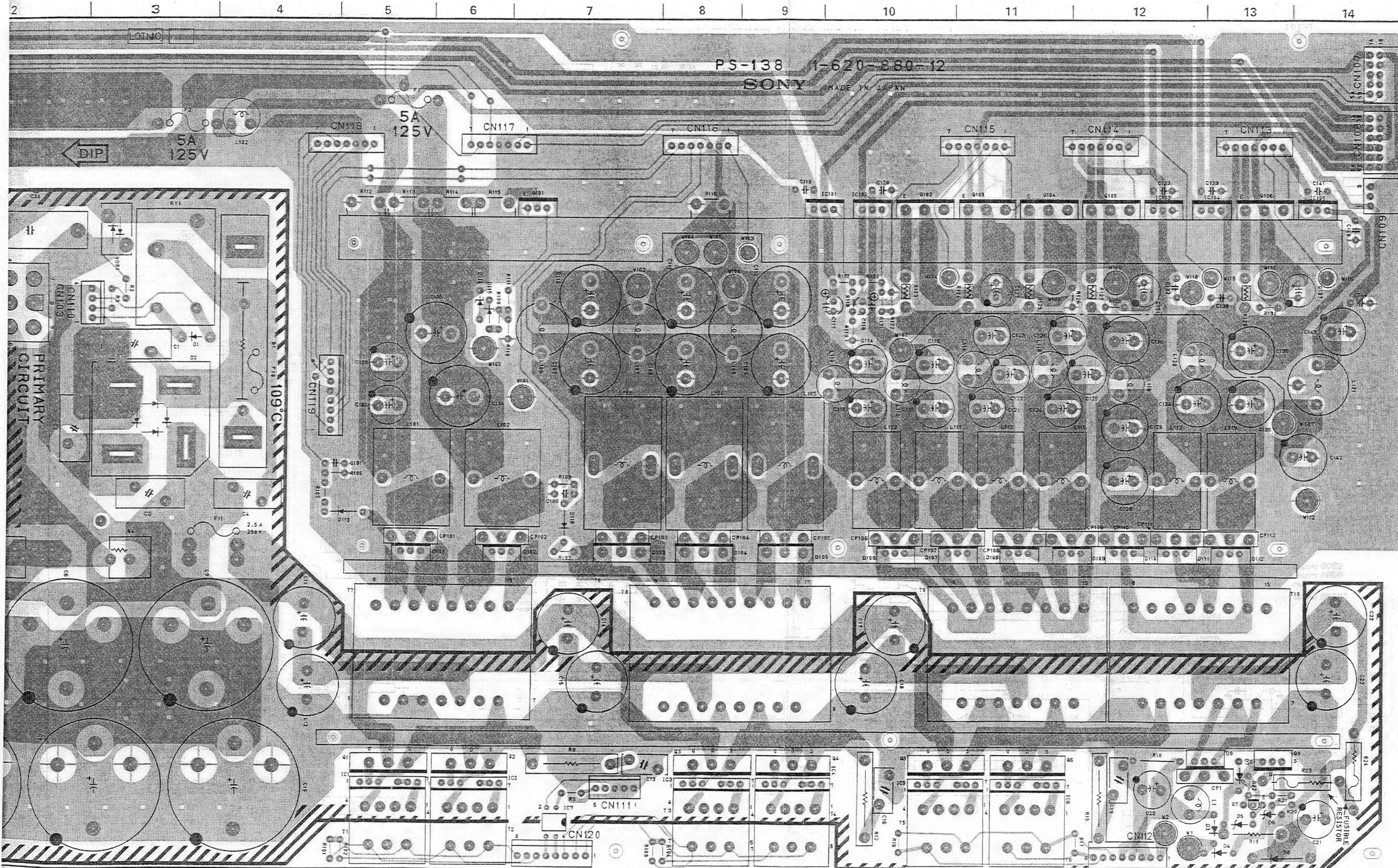

1-620-880-12 SOLDER SIDE

POWER SUPPLY

CT-74 BOARD : Regulator Controller
PS-138 BOARD : Power Supply
RE-32 BOARD : Switching Regulator

CT-74, PS-138, RE-32 POWER SUPPLY

PRIMARY CIRCUIT ← → SECONDARY CIRCUIT

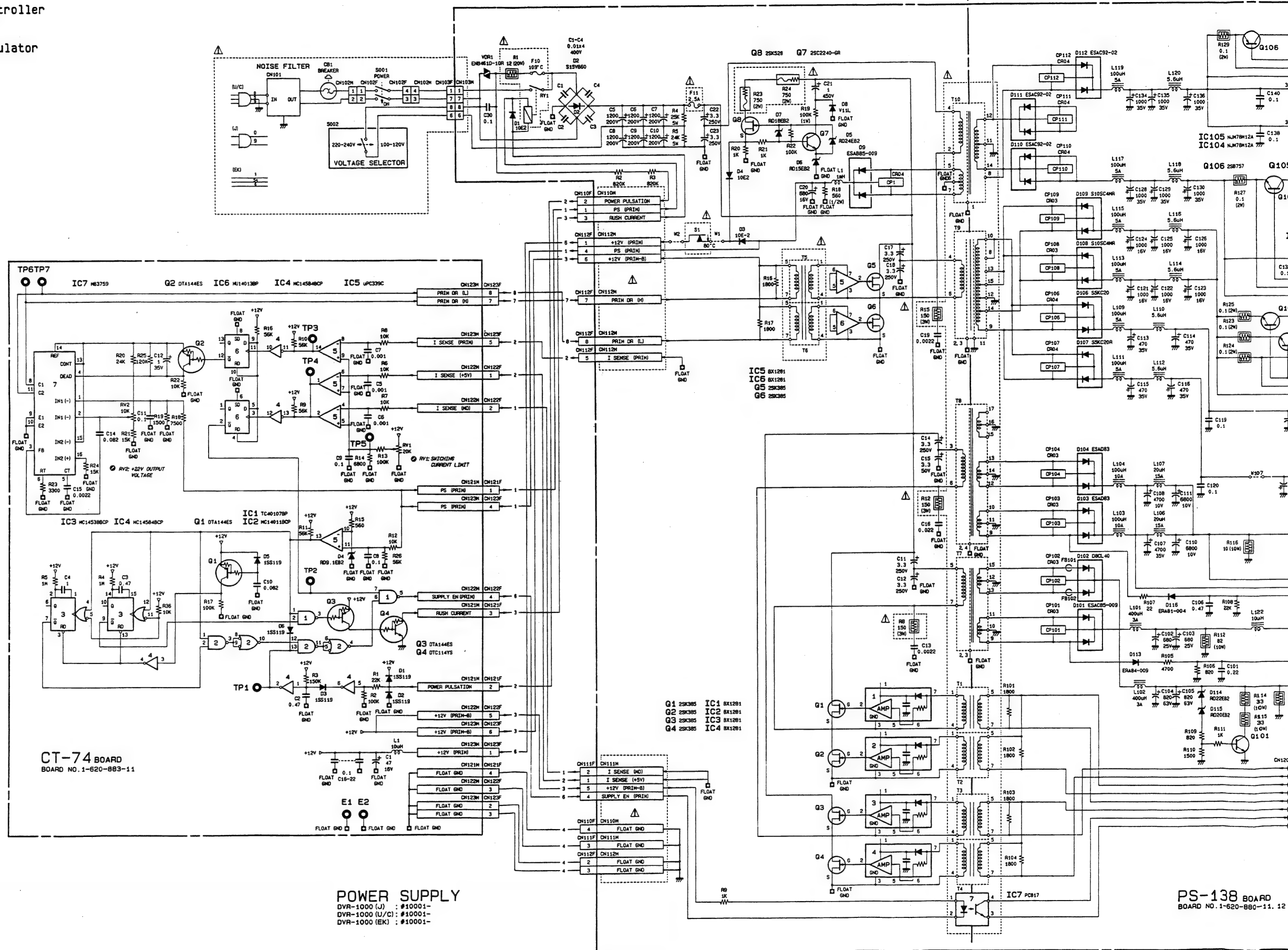

CT-74 BOARD
 BOARD NO. 1-620-883-11

PS-138 BOARD
 BOARD NO. 1-620-880-11. 12

POWER SUPPLY
 DVR-1000 (J) : #10001-
 DVR-1000 (U/C) : #10001-
 DVR-1000 (EK) : #10001-

CT-74, PS-138, RE-32 POWER SUPPLY POWER SUPPLY CT-74, PS-138, RE-32

UIT

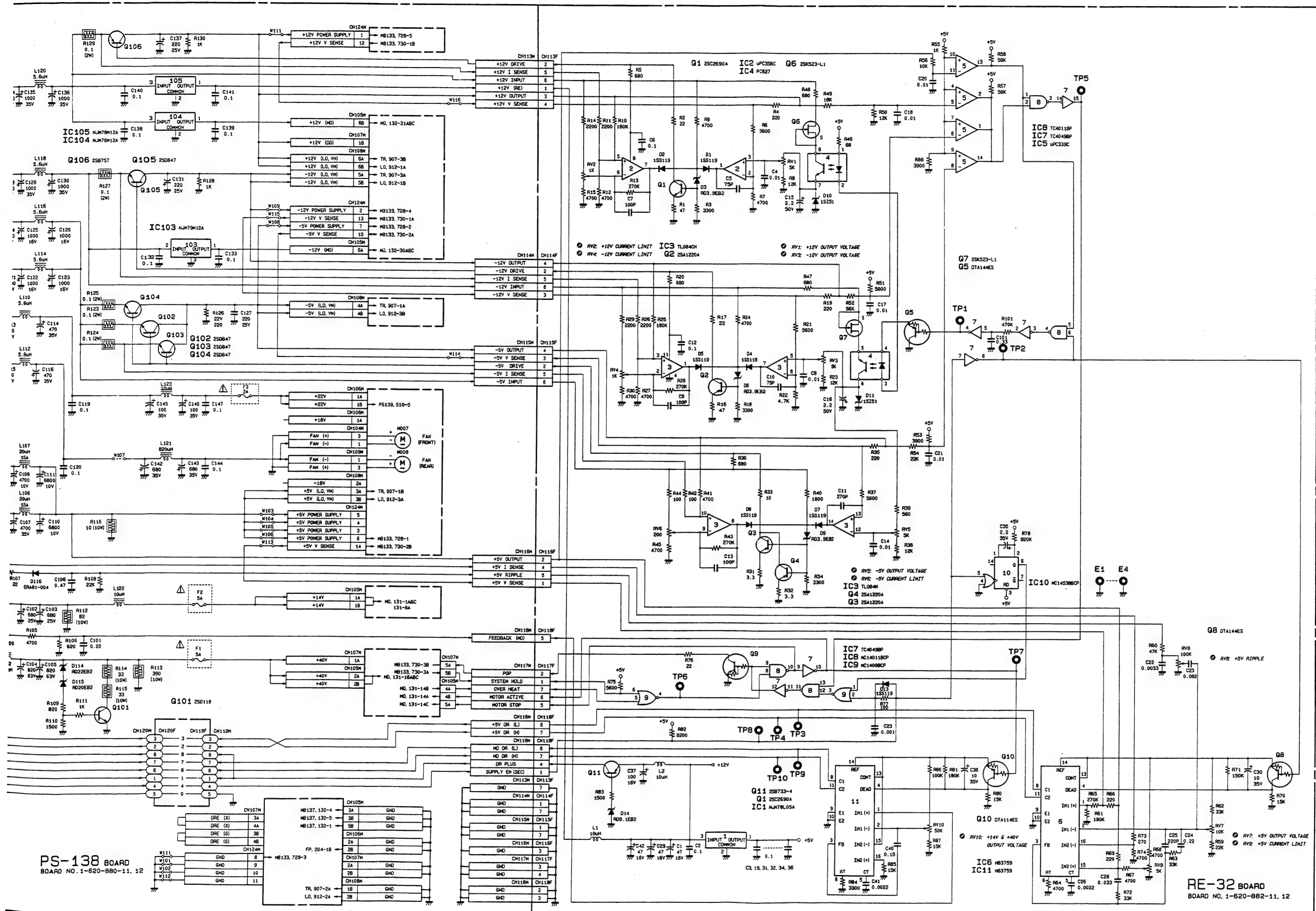

PS-138 BOARD
BOARD NO. 1-620-880-11. 12

RE-32 BOARD
BOARD NO. 1-620-882-11. 12

MB-133 BOARD (1-620-904-11)
Component Side

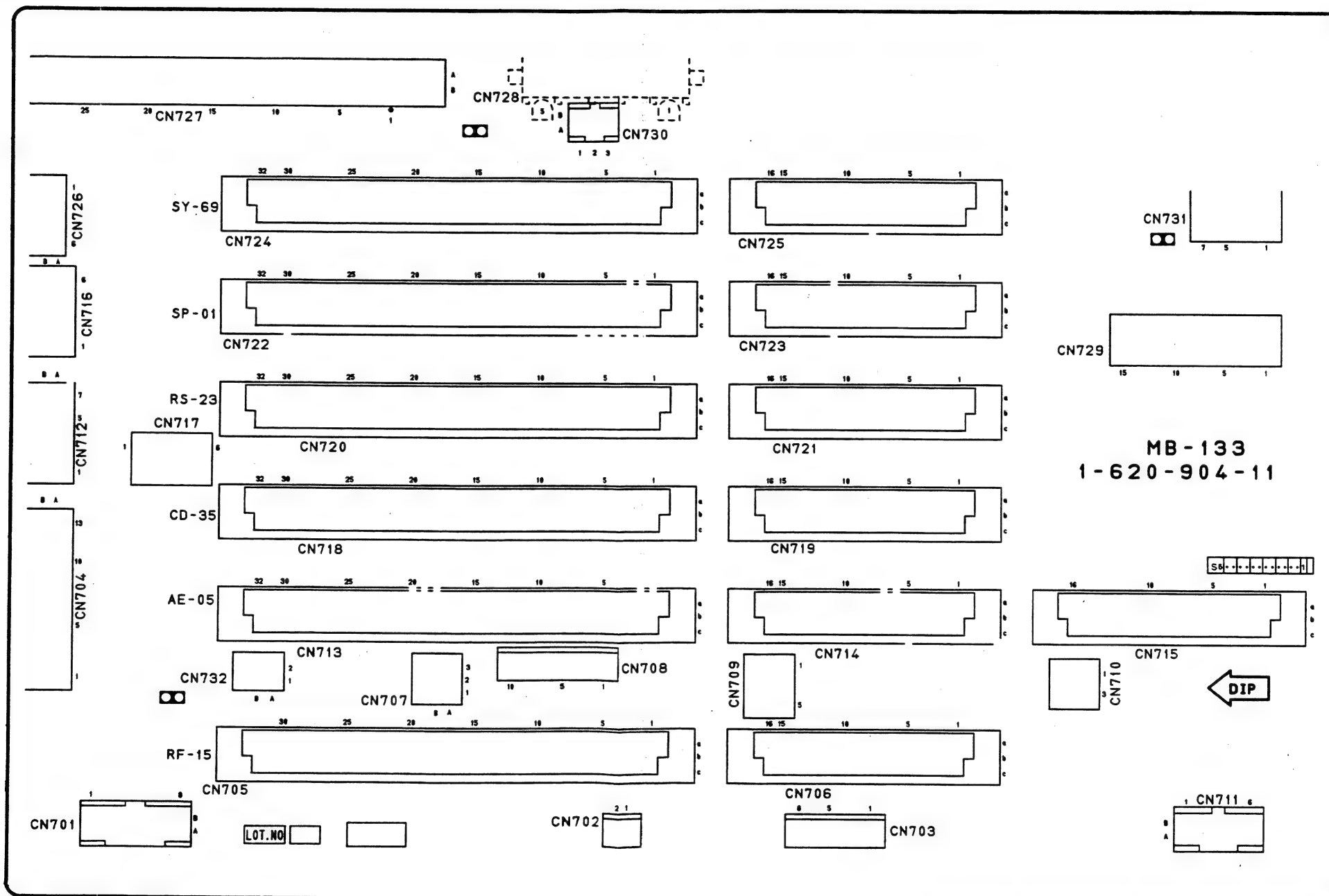

MB-133 BOARD
Mother Board

CARD RACK MB-133 BOARD MB-133 BOARD CARD RACK

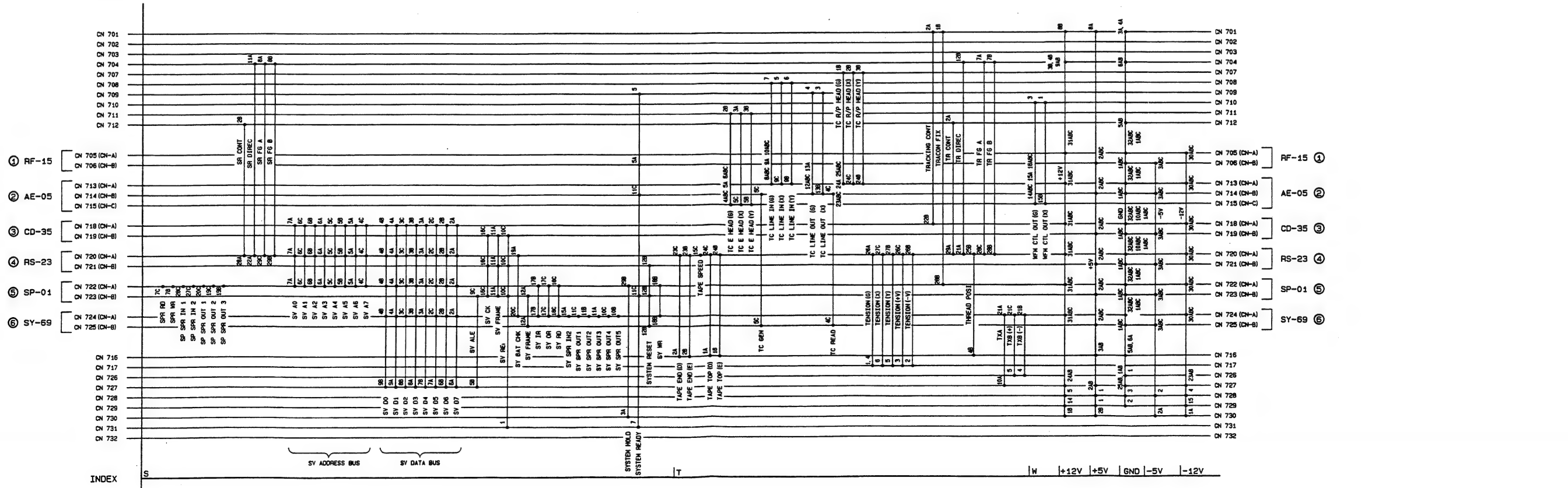
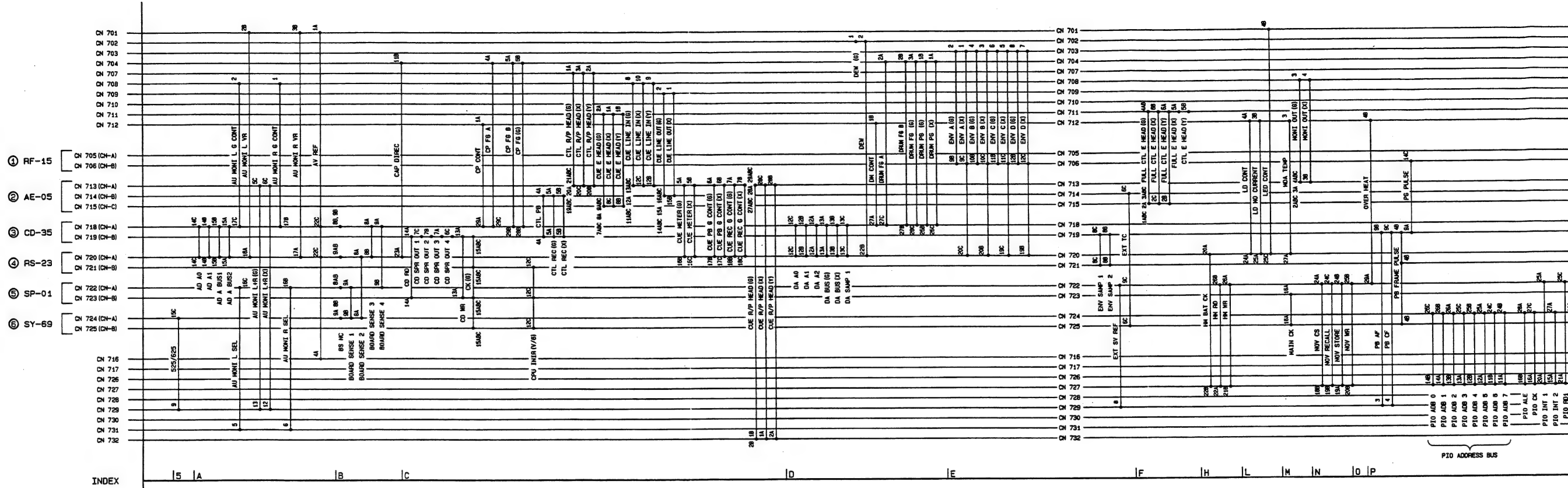

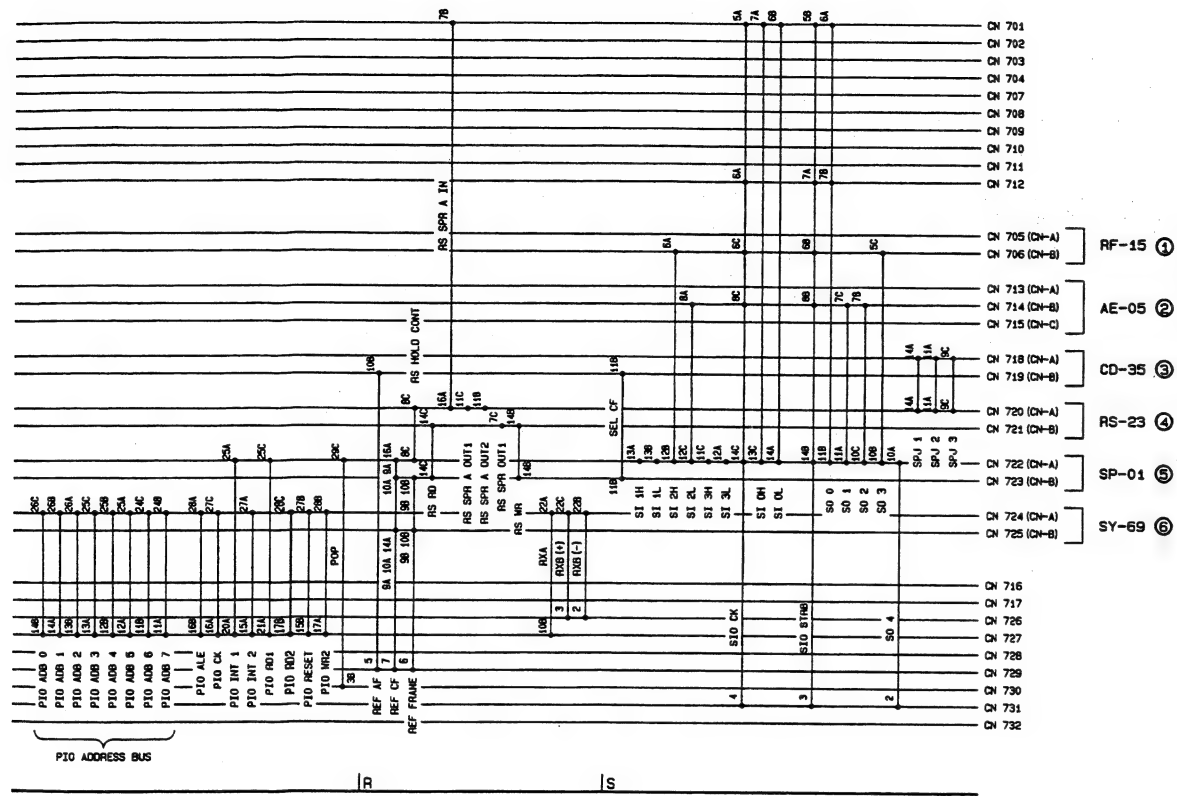

MB-133 BOARD
 BOARD NO. 1-320-904-11
 DVR-1000 (J) : #10001-
 DVR-1000 (U/C) : #10001-
 DVR-1000 (EK) : #10001-

CC-29, CS-21, LE-52, LE-56, PC-34
PC-37, PE-18, SE-47, SW-179, TR-41

SENSOR FRAME WIRING (1/2)



FRAME WIRING (1/2)

SENSOR

CC-29, CS-21, LE-52, LE-56, PC-34
PC-37, PE-18, SE-47, SW-179, TR-41



CC-29 BOARD (1-620-911-11)
Component Side

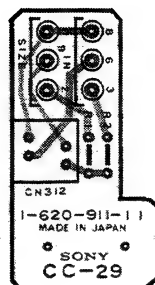

1-620-911-11 COMPONENT SIDE
1-620-911-11 SOLDER SIDE

CS-21 BOARD (1-620-910-12)
Component Side

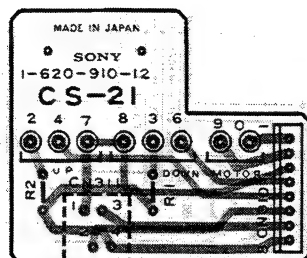

1-620-910-12 COMPONENT SIDE
1-620-910-12 SOLDER SIDE

LE-52 BOARD (1-620-897-11)
Component Side

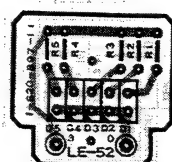

1-620-897-11 COMPONENT SIDE
1-620-897-11 SOLDER SIDE

SE-47 BOARD (1-620-894-11)
Component Side

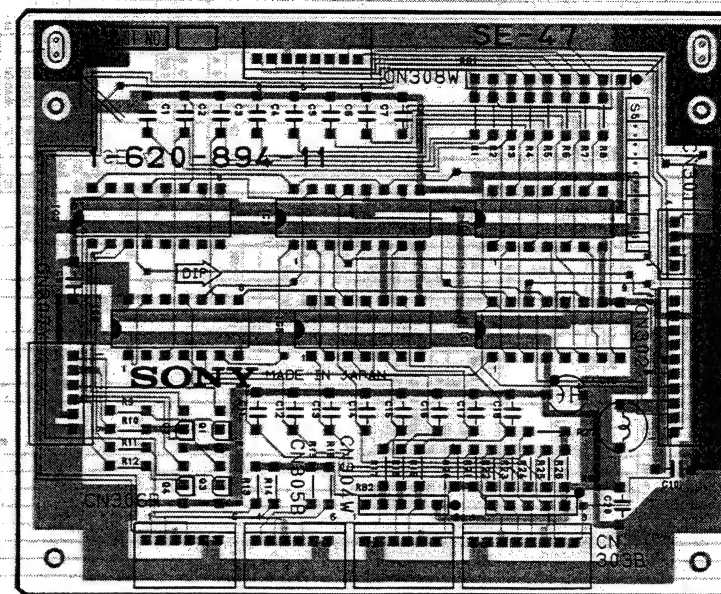

1-620-894-11 COMPONENT SIDE
1-620-894-11 SOLDER SIDE

LE-56 BOARD (1-620-908-11)
Component Side

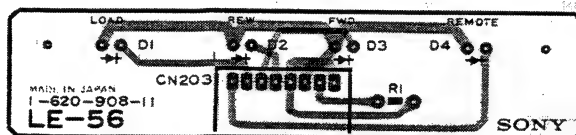

1-620-908-11 COMPONENT SIDE
1-620-908-11 SOLDER SIDE

PC-34 BOARD (1-620-895-11)
Component Side

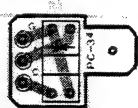

1-620-895-11 COMPONENT SIDE
1-620-895-11 SOLDER SIDE

PC-37 BOARD (1-621-344-11)
Component Side

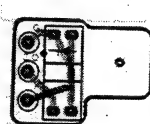

1-621-344-11 COMPONENT SIDE
1-621-344-11 SOLDER SIDE

PE-18 BOARD (1-620-916-11)
Component Side

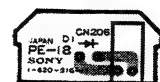

1-620-916-11 COMPONENT SIDE
1-620-916-11 SOLDER SIDE

SW-179 BOARD (1-620-915-11)
Component Side

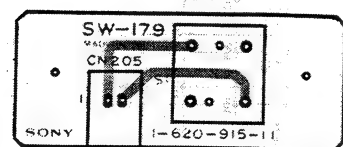

1-620-915-11 COMPONENT SIDE
1-620-915-11 SOLDER SIDE

TR-41 BOARD (1-620-898-11)
Component Side

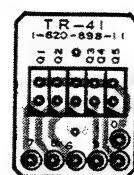

1-620-898-11 COMPONENT SIDE
1-620-898-11 SOLDER SIDE



FRAME WIRING (1/2) : SENSOR

- CC-29 BOARD
Cassette Controller (MOVE)
- CS-21 BOARD
Cassette Controller (FIX)
- LE-52 BOARD
Coding Hole Sensor (LED)
- LE-56 BOARD
Indicator (LOAD & RUN)
- PC-34 BOARD
Sensor User Hole & Reel Position
- PC-37 BOARD
Sensor Cassete IN/UP/DOWN
- PE-18 BOARD
Power, Indicator
- SE-47 BOARD
Sensor, Relaying
- SW-179 BOARD
Eject, Switch
- TR-41 BOARD
Coding Hole Sensor (PTR)

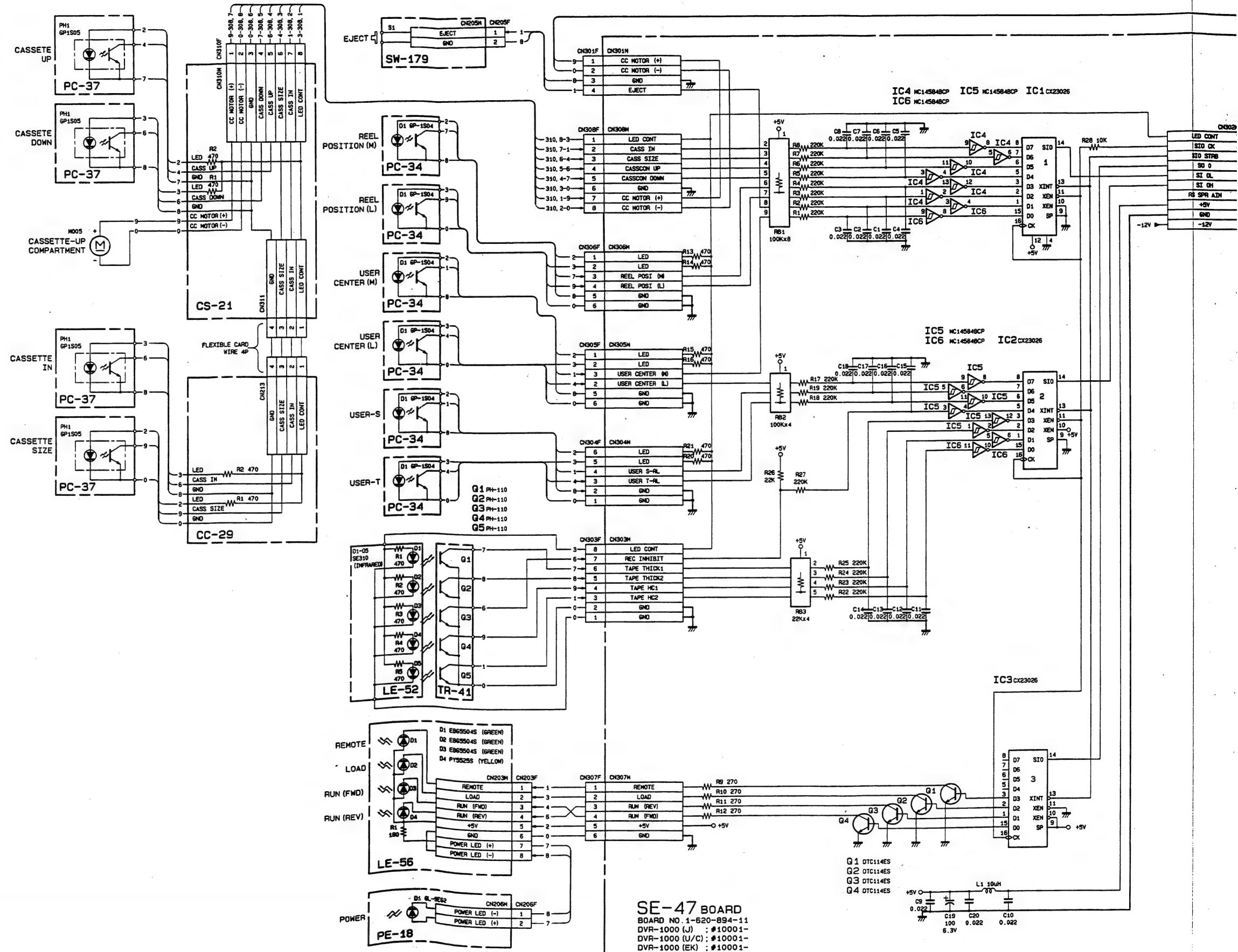



SE-47 BOARD

| Ref. No. | Pin No. | |
|----------|---------|-----|
| | +5V | GND |
| IC 1 | 12 | 4 |
| IC 2 | 12 | 4 |
| IC 3 | 12 | 4 |
| IC 4 | 14 | 7 |
| IC 5 | 14 | 7 |
| IC 6 | 14 | 7 |

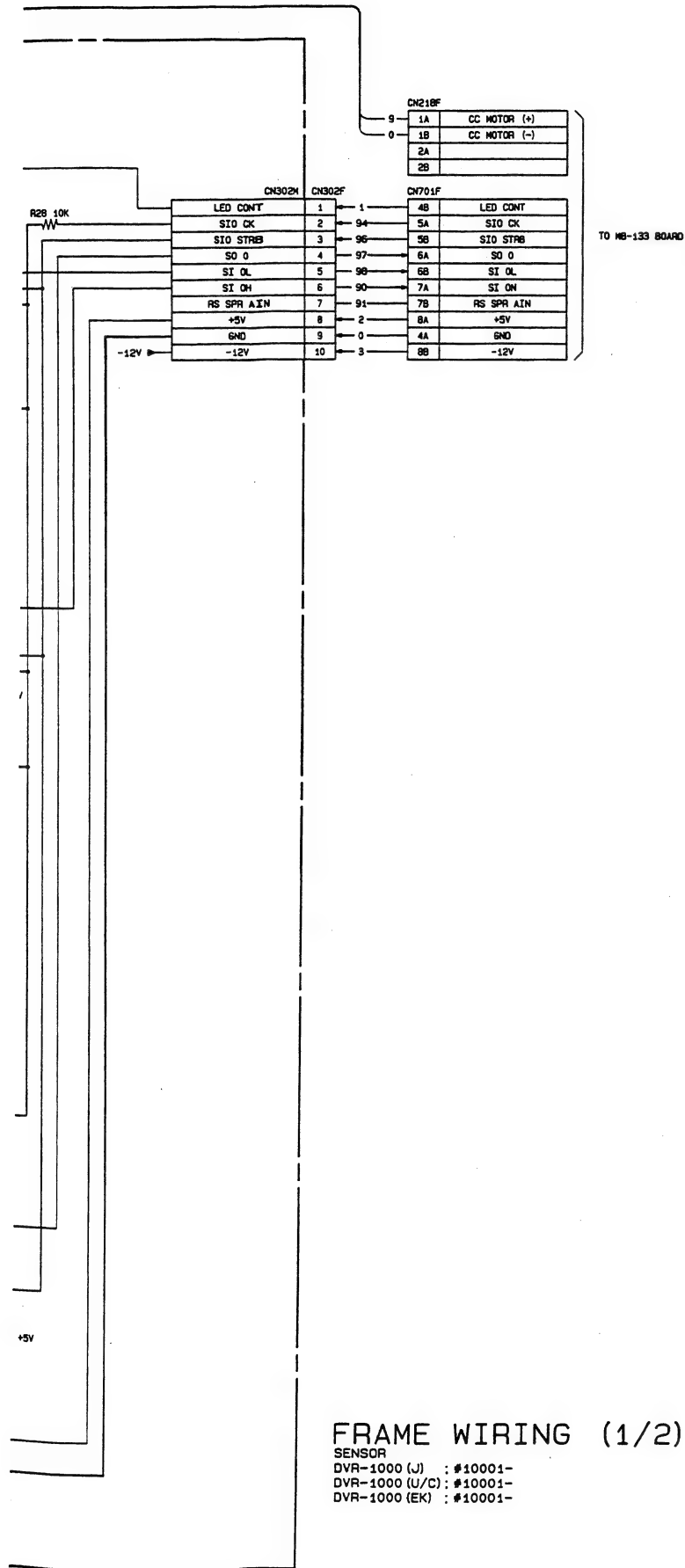

FRAME WIRING (1/2)

SENSOR
 DVR-1000 (J) : #10001-
 DVR-1000 (U/C) : #10001-
 DVR-1000 (EK) : #10001-

GRAPH 13-32

| WIRING | TYPE | NO. |
|--------|------|-----|
| 1 | 1 | 1 |
| 2 | 1 | 1 |
| 3 | 1 | 1 |
| 4 | 1 | 1 |
| 5 | 1 | 1 |
| 6 | 1 | 1 |
| 7 | 1 | 1 |
| 8 | 1 | 1 |
| 9 | 1 | 1 |
| 10 | 1 | 1 |
| 11 | 1 | 1 |
| 12 | 1 | 1 |
| 13 | 1 | 1 |
| 14 | 1 | 1 |
| 15 | 1 | 1 |
| 16 | 1 | 1 |
| 17 | 1 | 1 |
| 18 | 1 | 1 |
| 19 | 1 | 1 |
| 20 | 1 | 1 |
| 21 | 1 | 1 |
| 22 | 1 | 1 |
| 23 | 1 | 1 |
| 24 | 1 | 1 |
| 25 | 1 | 1 |
| 26 | 1 | 1 |
| 27 | 1 | 1 |
| 28 | 1 | 1 |
| 29 | 1 | 1 |
| 30 | 1 | 1 |
| 31 | 1 | 1 |
| 32 | 1 | 1 |

AH-13 BOARD (1-620-899-12)
 Component Side

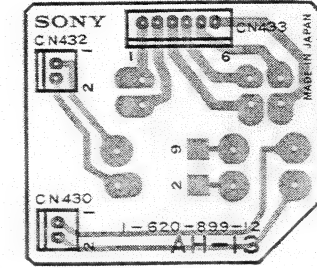

1-620-899-12 COMPONENT SIDE
 1-620-899-12 SOLDER SIDE

AH-15 BOARD (1-620-947-12)
 Component Side

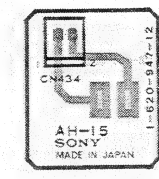

1-620-947-12 COMPONENT SIDE
 1-620-947-12 SOLDER SIDE

DE-17 BOARD (1-620-913-11)
 Component Side

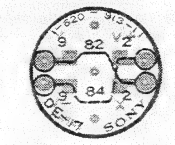

1-620-913-11 SOLDER SIDE

FC-37 BOARD (1-620-909-11)
 Component Side

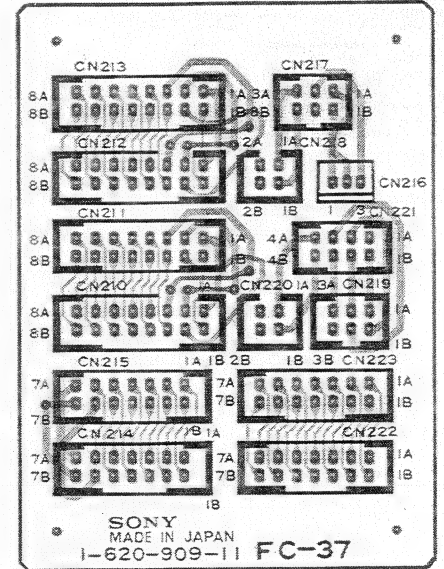

1-620-909-11 COMPONENT SIDE
 1-620-909-11 SOLDER SIDE

ING (1/2) SMI

Life Controller (MVE)

Life Controller (LIX)

or Capable IN/OUTPUT

Indicator

BP-10 BOARD (1-620-912-11)

Component Side

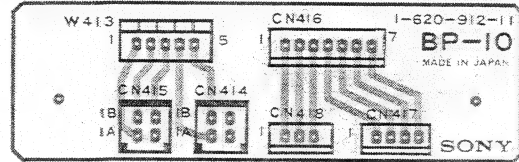

1-620-912-11 COMPONENT SIDE
1-620-912-11 SOLDER SIDE

CN-157 BOARD (1-620-892-11)

Component Side

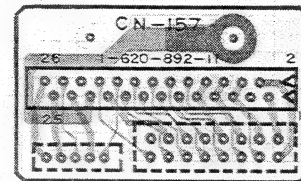

1-620-892-11 COMPONENT SIDE
1-620-892-11 SOLDER SIDE

CN-191 BOARD (1-621-346-11)

Component Side

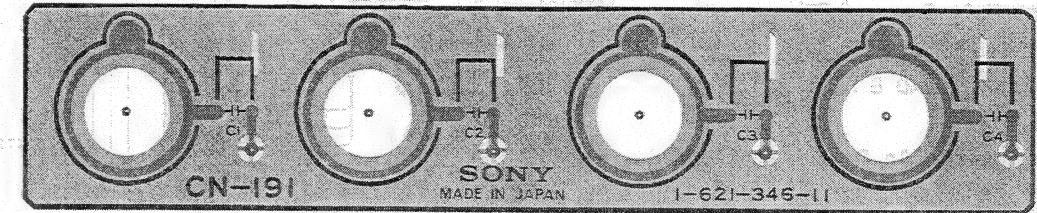

1-621-346-11 COMPONENT SIDE
1-621-346-11 SOLDER SIDE

FP-24 BOARD (1-620-914-11)

Component Side

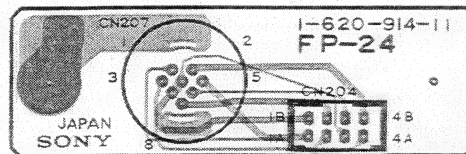

1-620-914-11 COMPONENT SIDE
1-620-914-11 SOLDER SIDE

MB-137 BOARD (1-620-893-11)

Component Side

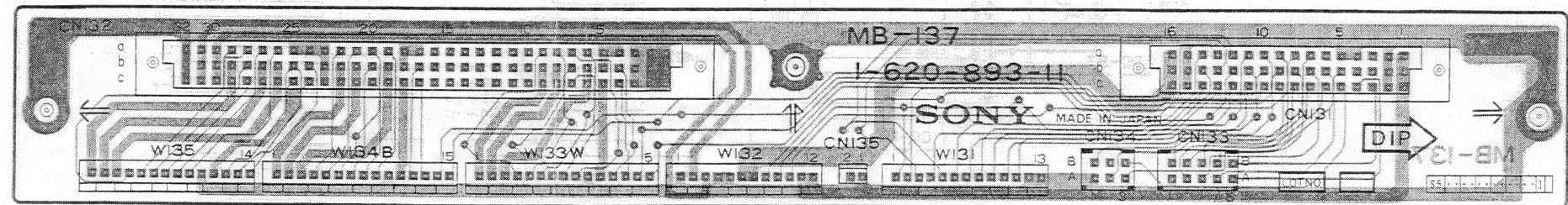

1-620-893-11 COMPONENT SIDE

1-620-893-11 SOLDER SIDE

PC-36 BOARD (1-620-896-11)

Component Side

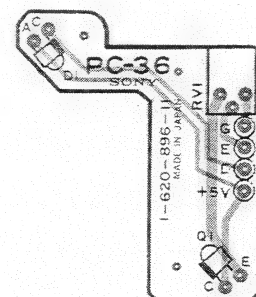

1-620-896-11 COMPONENT SIDE
1-620-896-11 SOLDER SIDE

VR-50 BOARD (1-620-907-11)

Component Side

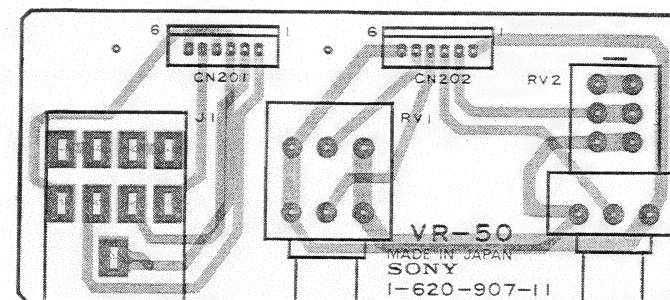

1-620-907-11 COMPONENT SIDE
1-620-907-11 SOLDER SIDE

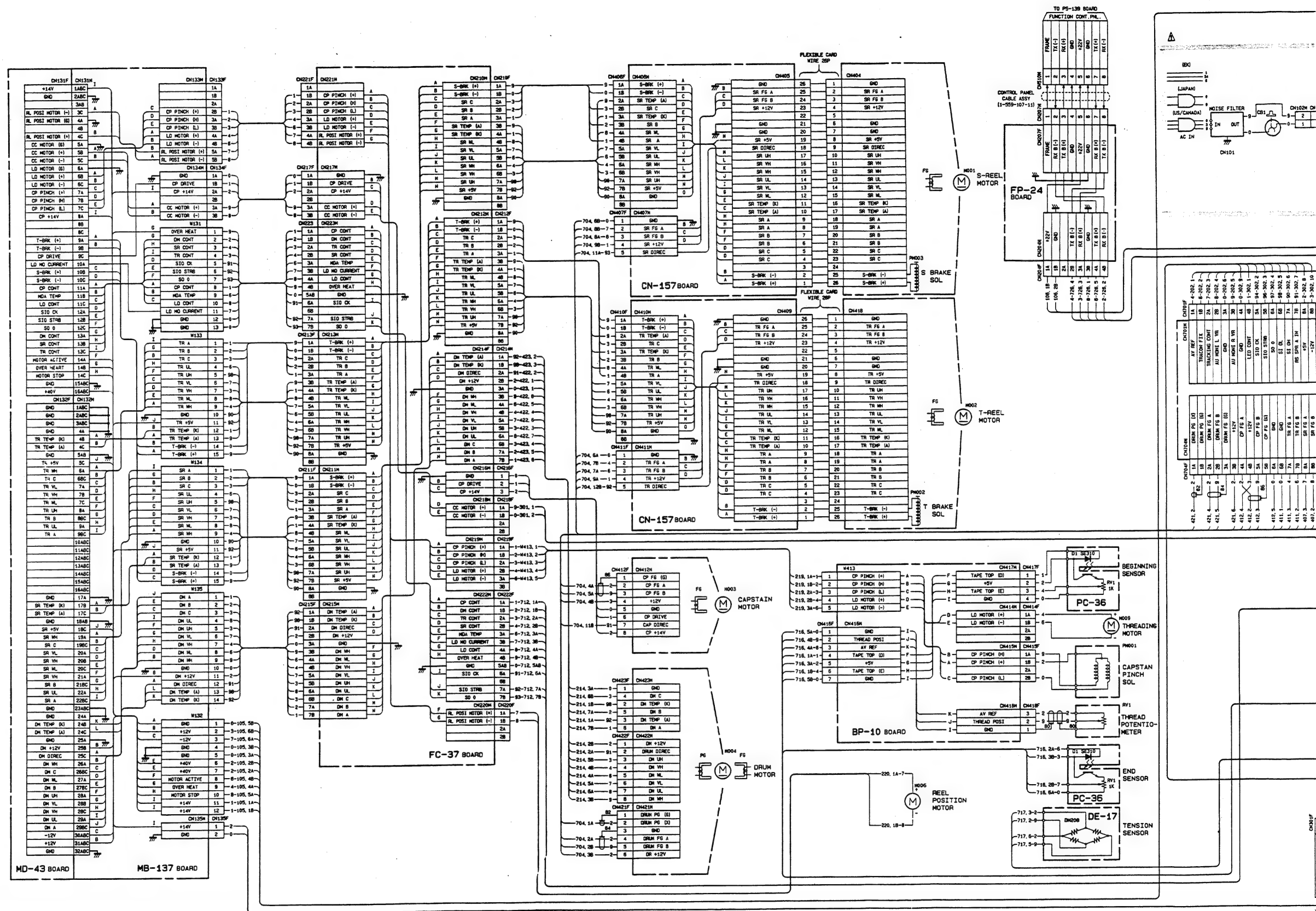

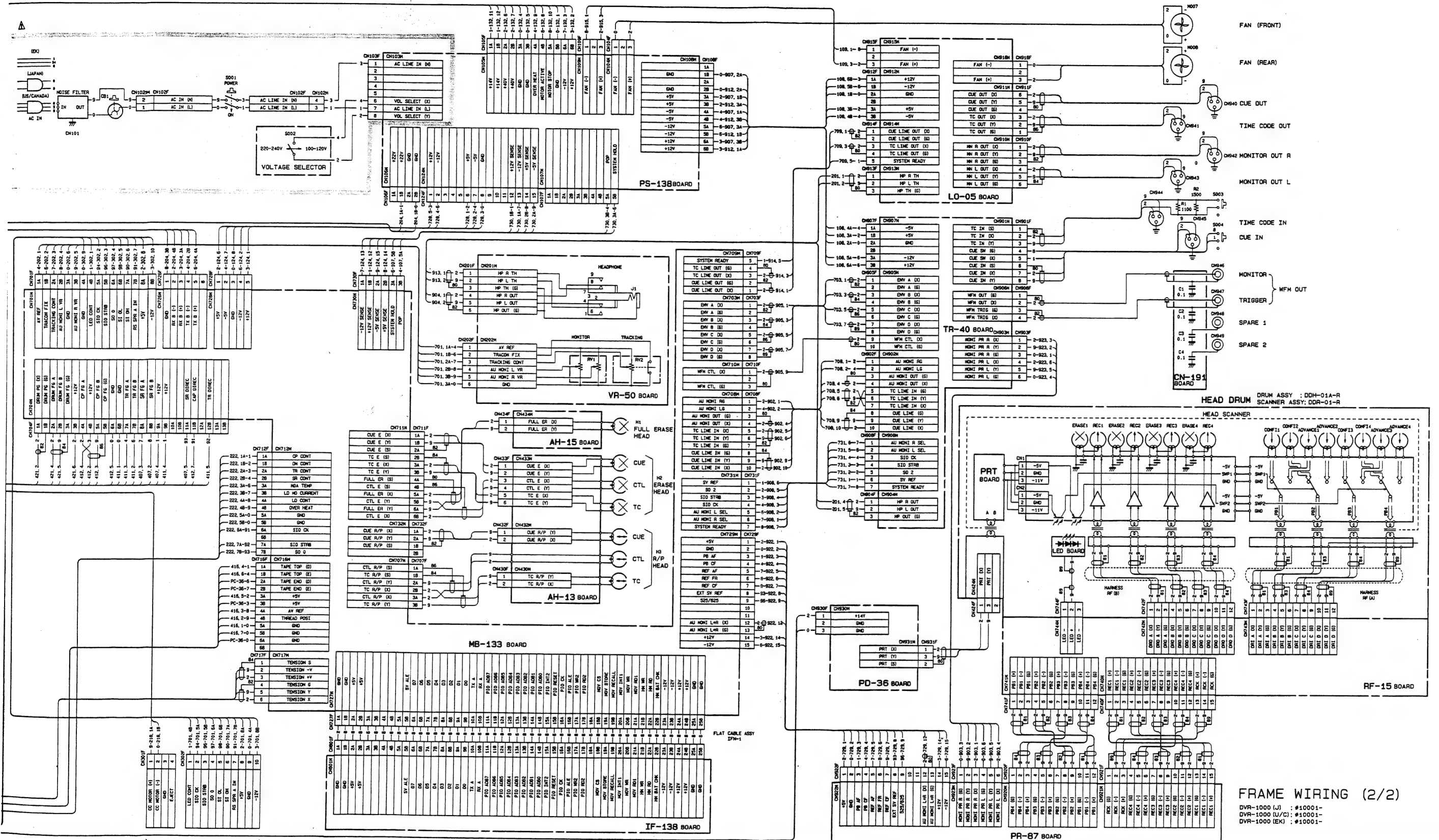

FRAME WIRING (2/2)
DVR-1000 (L): #10001-
DVR-1000 (U/C): #10001-
DVR-1000 (EK): #10001-

SECTION C

SEMICONDUCTOR PIN ASSIGNMENTS

この章の図の中には互換性のないダイオード、トランジスタ、ICが併記されていることがあります。部品を交換するときには必ず部品表を参照して下さい。

等価回路はICメーカーのData Bookに従いました。

The chart in this section may sometimes show diodes, transistors, and ICs that are not interchangeable. When replacing a component, be sure to refer to the parts list.

The circuit diagram of each IC is obtained from the IC data book published by the manufacturer.

| TYPE | PAGE | TYPE | PAGE | TYPE | PAGE | TYPE | PAGE |
|----------------|------|-------------------|------|--------------------|------|---------------------|------|
| 10E-2..... | C-3 | AM26LS30PC..... | C-5 | GL-9PG2..... | C-3 | LM317T..... | C-28 |
| 11DQ04..... | C-3 | AM26LS31PC..... | C-5 | GP-1S04..... | C-3 | LM319N..... | C-28 |
| 1S1555..... | C-3 | AM26LS32AC..... | C-5 | GP-1S05..... | C-3 | LM337T..... | C-28 |
| 1S2076..... | C-3 | AM26LS32PC..... | C-5 | GP08D..... | C-3 | LM358P..... | C-28 |
| 1S2473..... | C-3 | AN79L09..... | C-5 | | | LN259P..... | C-3 |
| 1SS106..... | C-3 | AN79M12..... | C-6 | | | LN35BP..... | C-3 |
| 1SS119..... | C-3 | | | HA178M05P..... | C-5 | | |
| 1SS120..... | C-3 | BA707..... | C-6 | HD10124..... | C-20 | M4049BP..... | C-7 |
| 1SS133..... | C-3 | BX1281..... | C-6 | HD14001BP..... | C-6 | M5238P..... | C-28 |
| 1SS148..... | C-3 | BX1320..... | C-6 | HD14011BP..... | C-6 | M5241L..... | C-28 |
| 1SS198..... | C-3 | BX1321..... | C-6 | HD14013BP..... | C-7 | MB3759..... | C-27 |
| 1SS97..... | C-3 | | | HD14046BP..... | C-7 | MB671131PF..... | C-29 |
| 1SZ51..... | C-3 | | | HD14051BP..... | C-7 | MB8416A-12P-SK..... | C-27 |
| | | CD74HC40105E..... | C-9 | HD14052BP..... | C-7 | MB8416A-15P-SK..... | C-27 |
| | | CF77074N..... | C-9 | HD14053BP..... | C-8 | MBM27C128-25..... | C-44 |
| 2SA1020..... | C-3 | CX23026..... | C-9 | HD14516BP..... | C-8 | MBM27C256-20..... | C-45 |
| 2SA1048..... | C-3 | CX23028..... | C-14 | HD14520BP..... | C-8 | MBM27C256-25..... | C-45 |
| 2SA1115..... | C-3 | CX7907A..... | C-10 | HD14538BP..... | C-21 | MBM27C32A-25..... | C-45 |
| 2SA1175..... | C-3 | CX7912A..... | C-12 | HD14556BP..... | C-8 | MBM27C32A-30..... | C-45 |
| 2SA1220A..... | C-3 | CXD1095Q..... | C-15 | HD14584BP..... | C-21 | MBM27C512-25..... | C-45 |
| 2SA715..... | C-3 | CXD1102Q..... | C-16 | HD7406P..... | C-21 | MBM27C64-25..... | C-44 |
| 2SA733..... | C-3 | CXQ70108P-8..... | C-46 | HD74HC00P..... | C-21 | MC14001BCP..... | C-6 |
| 2SA773..... | C-3 | CXQ71011P..... | C-17 | HD74HC02P..... | C-21 | MC14011BCP..... | C-6 |
| 2SA844..... | C-3 | CXQ71054P..... | C-18 | HD74HC04P..... | C-21 | MC14013BCP..... | C-7 |
| 2SA872..... | C-3 | CXQ71059P..... | C-20 | HD74HC08P..... | C-22 | MC14046BCP..... | C-7 |
| 2SA872A..... | C-3 | CXQ71086P..... | C-18 | HD74HC107P..... | C-22 | MC14051BCP..... | C-7 |
| 2SA933S..... | C-3 | | | HD74HC11P..... | C-22 | MC14052BCP..... | C-7 |
| 2SA966..... | C-3 | DA210S..... | C-3 | HD74HC123P..... | C-22 | MC14053BCP..... | C-8 |
| 2SA979..... | C-3 | DAP209S..... | C-3 | HD74HC125P..... | C-22 | MC14516BCP..... | C-8 |
| 2SB1013..... | C-3 | DM211..... | C-3 | HD74HC126P..... | C-22 | MC14520BCP..... | C-8 |
| 2SB1142..... | C-3 | DM208..... | C-3 | HD74HC138P..... | C-22 | MC14538BCP..... | C-21 |
| 2SB733..... | C-3 | DS1210..... | C-20 | HD74HC139P..... | C-22 | MC14556BCP..... | C-8 |
| 2SB734..... | C-3 | DS1235Y..... | C-20 | HD74HC14P..... | C-23 | MC14584BCP..... | C-21 |
| 2SB739..... | C-3 | DSAL12..... | C-3 | HD74HC153P..... | C-23 | MC34050P..... | C-30 |
| 2SB740..... | C-3 | DSAL1C2..... | C-3 | HD74HC157P..... | C-23 | MC3486P..... | C-30 |
| 2SB757..... | C-4 | DTA124ES..... | C-4 | HD74HC161P..... | C-23 | MC74HC00N..... | C-21 |
| 2SC1162..... | C-4 | DTA144ES..... | C-4 | HD74HC164P..... | C-23 | MC74HC02N..... | C-21 |
| 2SC1740S..... | C-4 | DTC114EF..... | C-4 | HD74HC165P..... | C-24 | MC74HC04N..... | C-21 |
| 2SC1775..... | C-4 | DTC114ES..... | C-4 | HD74HC174P..... | C-24 | MC74HC08N..... | C-22 |
| 2SC1775A..... | C-4 | DTC114YS..... | C-4 | HD74HC175P..... | C-24 | MC74HC107N..... | C-22 |
| 2SC2001..... | C-4 | DTC124EF..... | C-4 | HD74HC244P..... | C-24 | MC74HC11N..... | C-22 |
| 2SC2120..... | C-4 | DTC124ES..... | C-4 | HD74HC245P..... | C-25 | MC74HC125N..... | C-22 |
| 2SC2240..... | C-4 | DTC144EF..... | C-4 | HD74HC273P..... | C-25 | MC74HC126N..... | C-22 |
| 2SC2458..... | C-4 | DTC144WS..... | C-4 | HD74HC32P..... | C-25 | MC74HC138N..... | C-22 |
| 2SC2603..... | C-4 | EAA5504S..... | C-3 | HD74HC327P..... | C-25 | MC74HC139N..... | C-22 |
| 2SC2655..... | C-4 | EBG5504S..... | C-3 | HD74HC373P..... | C-25 | MC74HC14F..... | C-23 |
| 2SC2690A..... | C-4 | EBR5504S..... | C-3 | HD74HC374P..... | C-26 | MC74HC14N..... | C-23 |
| 2SC2785..... | C-4 | EQA02..... | C-3 | HD74HC4040P..... | C-26 | MC74HC153N..... | C-23 |
| 2SC2878-B..... | C-4 | ERA81-004..... | C-3 | HD74HC4538P..... | C-26 | MC74HC157N..... | C-23 |
| 2SC945..... | C-4 | ERA84-009..... | C-3 | HD74HC74P..... | C-26 | MC74HC161N..... | C-23 |
| 2SD1118..... | C-4 | ERB12..... | C-3 | HD74HC86P..... | C-26 | MC74HC164N..... | C-23 |
| 2SD1682..... | C-4 | ERB44..... | C-3 | HI1-0201-5..... | C-27 | MC74HC165N..... | C-24 |
| 2SD774..... | C-4 | ERB84-009..... | C-3 | HM6116ALSP-12..... | C-27 | MC74HC174N..... | C-24 |
| 2SD789..... | C-4 | ERC84-009..... | C-3 | HM6116ALSP-15..... | C-27 | MC74HC175N..... | C-24 |
| 2SD847..... | C-4 | ESAB85-009..... | C-3 | HM6148HP-45..... | C-27 | MC74HC221N..... | C-30 |
| 2SD998..... | C-4 | ESAC25-02C..... | C-3 | HM6148HP-55..... | C-27 | MC74HC244N..... | C-24 |
| 2SJ122..... | C-4 | ESAC85-009..... | C-3 | HZ3.9EB..... | C-3 | MC74HC245N..... | C-25 |
| 2SK385..... | C-4 | ESAC92..... | C-3 | HZ5.1EB..... | C-3 | MC74HC273N..... | C-25 |
| 2SK428..... | C-4 | ESAD83..... | C-3 | | | MC74HC32N..... | C-25 |
| 2SK523..... | C-4 | | | | | MC74HC367N..... | C-25 |
| 2SK528..... | C-4 | FT5761M..... | C-20 | | | | |

SEMICONDUCTOR INDEX

| TYPE | PAGE |
|------------------|------|
| MC74HC373N..... | C-25 |
| MC74HC374N..... | C-26 |
| MC74HC4040N..... | C-26 |
| MC74HC4053N..... | C-30 |
| MC74HC4538N..... | C-26 |
| MC74HC541N..... | C-31 |
| MC74HC573N..... | C-31 |
| MC74HC574N..... | C-31 |
| MC74HC74N..... | C-26 |
| MC74HC86N..... | C-26 |
| MC74HCU04N..... | C-21 |
| MP6901..... | C-31 |
| MSM4049BRS..... | C-7 |
| | |
| NJM082D..... | C-31 |
| NJM2043D-D..... | C-28 |
| NJM2901N..... | C-31 |
| NJM2903D..... | C-6 |
| NJM2904D..... | C-31 |
| NJM4556D..... | C-31 |
| NJM4558D..... | C-6 |
| NJM4559D..... | C-31 |
| NJM4560D..... | C-31 |
| NJM78L09A..... | C-5 |
| NJM78M05A..... | C-32 |
| NJM78M12A..... | C-32 |
| NJM79L09A..... | C-32 |
| NJM79M12A..... | C-32 |
| | |
| PC627..... | C-32 |
| PC817..... | C-3 |
| PH110..... | C-3 |
| PY5525S..... | C-3 |
| | |
| RD13EB..... | C-3 |
| RD15EB..... | C-3 |
| RD16EB..... | C-3 |
| RD18EB..... | C-3 |
| RD20EB..... | C-3 |
| RD22EB..... | C-3 |
| RD24EB..... | C-3 |
| RD3.9EB..... | C-3 |
| RD4.3EB..... | C-3 |
| RD5.1EB..... | C-3 |
| RD9.1EB..... | C-3 |
| | |
| S10SC4MR..... | C-3 |
| S15VB60..... | C-3 |
| S5277B..... | C-3 |
| S5KC20..... | C-3 |
| S5KC20R..... | C-3 |
| SE310..... | C-3 |
| SIB01..... | C-3 |
| SN7406N..... | C-21 |
| SN74HC00N..... | C-21 |
| SN74HC02N..... | C-21 |
| SN74HC04N..... | C-21 |
| SN74HC08N..... | C-22 |
| SN74HC107N..... | C-22 |
| SN74HC11N..... | C-22 |
| SN74HC125N..... | C-22 |
| SN74HC126N..... | C-22 |
| SN74HC138N..... | C-22 |
| SN74HC139N..... | C-22 |
| SN74HC14N..... | C-23 |
| SN74HC153N..... | C-23 |
| SN74HC157N..... | C-23 |
| SN74HC161N..... | C-23 |
| SN74HC164N..... | C-23 |
| SN74HC165N..... | C-24 |
| SN74HC174N..... | C-24 |
| SN74HC175N..... | C-24 |
| SN74HC244N..... | C-24 |
| SN74HC245N..... | C-25 |
| SN74HC273N..... | C-25 |
| SN74HC32N..... | C-25 |
| SN74HC373N..... | C-25 |
| SN74HC374N..... | C-25 |
| SN74HC377N..... | C-25 |
| SN74HC4040N..... | C-26 |
| SN74HC541N..... | C-31 |
| SN74HC573N..... | C-31 |
| SN74HC574N..... | C-31 |
| SN74HC74N..... | C-26 |
| SN74HC86N..... | C-26 |

| TYPE | PAGE |
|------------------|------|
| SN74HCU04N..... | C-21 |
| SN75160AN..... | C-32 |
| SN75161AN..... | C-33 |
| SN76489AN..... | C-33 |
| | |
| TA7257P..... | C-33 |
| TA7267P..... | C-34 |
| TA7368P..... | C-34 |
| TA78L005AP..... | C-34 |
| TA78L009AP..... | C-34 |
| TC4001BP..... | C-6 |
| TC40107BP..... | C-34 |
| TC4011BP..... | C-6 |
| TC4049BP..... | C-7 |
| TC4051BP..... | C-7 |
| TC4052BP..... | C-7 |
| TC4053BP..... | C-8 |
| TC4516BP..... | C-8 |
| TC4520BP..... | C-8 |
| TC4538BP..... | C-21 |
| TC4556BP..... | C-8 |
| TC5020BP..... | C-34 |
| TC504013BP..... | C-31 |
| TC74HC00P..... | C-21 |
| TC74HC02P..... | C-21 |
| TC74HC04P..... | C-21 |
| TC74HC08F..... | C-22 |
| TC74HC08P..... | C-22 |
| TC74HC107P..... | C-22 |
| TC74HC11P..... | C-22 |
| TC74HC123P..... | C-22 |
| TC74HC138P..... | C-22 |
| TC74HC139P..... | C-22 |
| TC74HC14F..... | C-23 |
| TC74HC14P..... | C-23 |
| TC74HC153P..... | C-23 |
| TC74HC157P..... | C-23 |
| TC74HC161P..... | C-23 |
| TC74HC164P..... | C-23 |
| TC74HC165P..... | C-24 |
| TC74HC174P..... | C-24 |
| TC74HC175P..... | C-24 |
| TC74HC221P..... | C-30 |
| TC74HC244F..... | C-24 |
| TC74HC244P..... | C-24 |
| TC74HC245P..... | C-25 |
| TC74HC273P..... | C-25 |
| TC74HC32P..... | C-25 |
| TC74HC367P..... | C-25 |
| TC74HC373P..... | C-25 |
| TC74HC374P..... | C-26 |
| TC74HC4040P..... | C-26 |
| TC74HC4538P..... | C-26 |
| TC74HC573P..... | C-31 |
| TC74HC574P..... | C-31 |
| TC74HC74F..... | C-26 |
| TC74HC74P..... | C-26 |
| TC74HC86P..... | C-26 |
| TC74HCU04P..... | C-21 |
| TL082CP..... | C-34 |
| TL084CN..... | C-34 |
| TL607CP..... | C-34 |
| TL7705AC..... | C-34 |
| | |
| U05E..... | C-3 |
| | |
| V06C..... | C-3 |
| V11L..... | C-3 |
| VP16V8E..... | C-45 |
| | |
| X2212P..... | C-30 |
| | |
| uPC1513HA..... | C-35 |
| uPC319C..... | C-35 |
| uPC339C..... | C-28 |
| uPC358C..... | C-28 |
| uPC393C..... | C-6 |
| uPC398C..... | C-28 |
| uPC4082C..... | C-34 |
| uPC4556C..... | C-35 |
| uPC4558C..... | C-6 |
| uPC648C..... | C-35 |
| uPC648D..... | C-35 |
| uPC78M05H..... | C-5 |

| TYPE | PAGE |
|--------------------|------|
| uPC78M12H..... | C-5 |
| uPC79M12H..... | C-6 |
| uPD3341C..... | C-35 |
| uPD4013BC..... | C-7 |
| uPD4051BC..... | C-7 |
| uPD4052BC..... | C-7 |
| uPD4053BC..... | C-8 |
| uPD43256G-10L..... | C-36 |
| uPD4364G-15L..... | C-17 |
| uPD4464C-15..... | C-17 |
| uPD4516BC..... | C-8 |
| uPD4520BC..... | C-8 |
| uPD4538BC..... | C-21 |
| uPD4556BC..... | C-8 |
| uPD4584BC..... | C-21 |
| uPD70108D-8..... | C-19 |
| uPD71011G..... | C-36 |
| uPD71054C..... | C-18 |
| uPD71054G..... | C-37 |
| uPD71059C..... | C-20 |
| uPD71059G..... | C-37 |
| uPD72001C..... | C-47 |
| uPD7201AC..... | C-38 |
| uPD7210C..... | C-39 |
| uPD7220AD-2..... | C-40 |
| uPD74HC123AC..... | C-22 |
| uPD74HC14G..... | C-23 |
| uPD74HC221AC..... | C-30 |
| uPD74HC245G..... | C-25 |
| uPD7506CT-211..... | C-42 |
| uPD78C10G..... | C-43 |

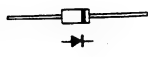

10E-2
1S1555
1S2076
1S2473
1SS119
1SS120
1SS133
1SS148

ERB84-009
ERB12-??
ERB44-??
ERB84-009
GP08-?
S5277B
S1B01-02

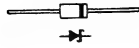

11D004
1SS106
1SS198
1SS97
ERB81-004
ERC84-009

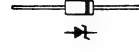

1SZ-??
EOA02
HZ-?EB?
RD-?EB?



DA210S



DAP209S

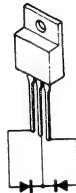

ESAB85-009
ESAC25-02C
ESAC85-009
ESAC92-02
SSKC20

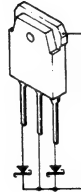

ESAD83



S10SC4MR
SSKC20R

BOTTOM VIEW

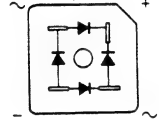

S15VB-??

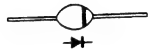

DSA1A-?
DSA1C-?
U05E
V06C
V11-?



EAA5504S : AMBER
EBG5504S : GREEN
EBR5504S : RED

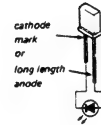

GL-9PG2 : GREEN



LN258P : RED
LN358P : GREEN



PV5525S : YELLOW



SE310 : INFRARED

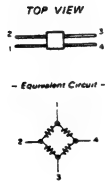

DM208

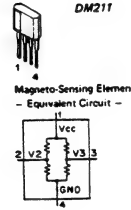

DM211

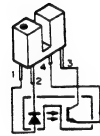
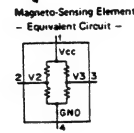

GP-1304
GP-1305

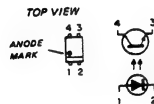

TOP VIEW
ANODE MARK

PC817



PH110



2SA1020
2SA773
2SA966
2SB739
2SB740



2SA1048
2SA1115
2SA933S



TYPE NO. PRINTED

2SA1175

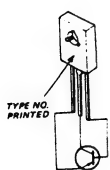

2SA1220A
2SA715

TYPE NO. PRINTED



2SA733
2SA844
2SA872
2SA872A
2SB1013

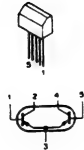

2SA979



2SB1142

TYPE NO. PRINTED



2SB733
2SB734

TRANSISTOR

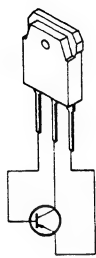

2SB757

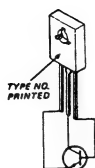

2SC1152
2SC2690A



2SC1740S
2SC2458
2SC2603



2SC1775
2SC1775A
2SC2120
2SC2240
2SC2878
2SC345



2SC2001
2SC2655
2SD789

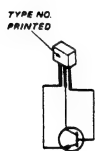

TYPE NO. PRINTED

2SC2785

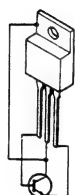

2SD1118

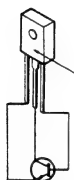

2SD1682

TYPE NO. PRINTED



2SD774



2SD847

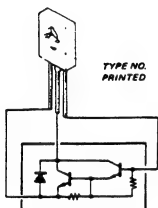

TYPE NO. PRINTED

2SD996



2SJ122

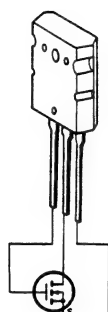

2SK385



2SK428



2SK523



2SK528



DTA124ES (R1=22K, R2=22K)
DTA144ES (R1=47K, R2=47K)

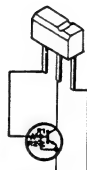

DTC114EF (R1=10K, R2=10K)
DTC124EF (R1=22K, R2=22K)
DTC144EF (R1=47K, R2=47K)



DTC114ES (R1=10K, R2=10K)
DTC114YS (R1=10K, R2=47K)
DTC124ES (R1=22K, R2=22K)
DTC144WS (R1=47K, R2=22K)

AM26LS30PC (ADVANCED MICRO DEVICES)
LINE DRIVER
— TOP VIEW —

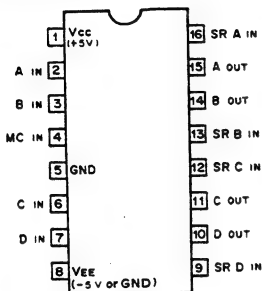

MC: MODE CONTROL
SR: SLEW RATE CONTROL

MC=1

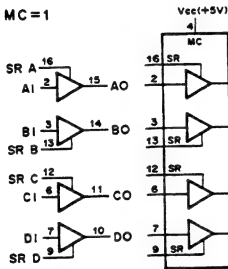

| INPUTS | OUTPUTS |
|--------|---------|
| MC | A TO D |
| 1 | 0 |
| 1 | 1 |

0: LOW LEVEL X: DON'T CARE
1: HIGH LEVEL HI-Z: HIGH IMPEDANCE

MC=0

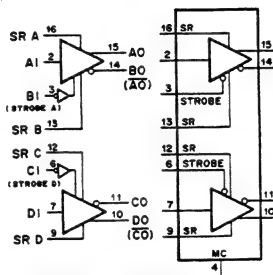

| INPUTS | OUTPUTS |
|--------|-----------|
| MC | A & B & C |
| 0 | 0 |
| 0 | 1 |
| 0 | X |
| 1 | X |

AM26LS31CN (TI)
AM26LS31PC (ADVANCED MICRO DEVICE)
HIGH SPEED DIFFERENTIAL LINE DRIVER
— TOP VIEW —

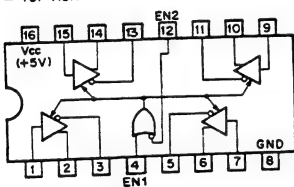

| EN2 | EN1 | OUTPUT |
|-----|-----|--------|
| 0 | 0 | ENABLE |
| 0 | 1 | ENABLE |
| 1 | 0 | HI-Z |
| 1 | 1 | ENABLE |

0: LOW LEVEL
1: HIGH LEVEL
HI-Z: HIGH IMPEDANCE

AM26LS32ACN (TI)
AM26LS32PC (ADVANCED MICRO DEVICES)
AM26LS33PC (ADVANCED MICRO DEVICES)
HIGH SPEED DIFFERENTIAL LINE RECEIVER
— TOP VIEW —

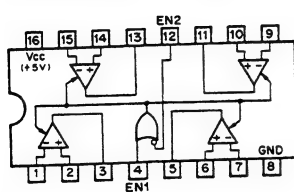

| EN2 | EN1 | OUTPUT |
|-----|-----|--------|
| 0 | 0 | ENABLE |
| 0 | 1 | ENABLE |
| 1 | 0 | HI-Z |
| 1 | 1 | ENABLE |

0: LOW LEVEL
1: HIGH LEVEL
HI-Z: HIGH IMPEDANCE

| SENSE | INPUT VOLT |
|-------|-------------|
| LS32 | ±200mV ±7V |
| LS33 | ±500mV ±15V |

AN78L?? (MATSUSHITA)

NJM78L??A (NEC)
uA78L??ACL (TI)
uA78L??AWV (FSC)
uPC78L??J (NEC)
POSITIVE VOLTAGE REGULATOR (100mA)

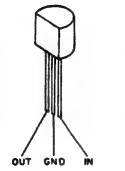

| OUTPUT VOLTAGE | NJM78L??A | uA78L??ACL | uA78L??AWV | uPC78L??J | AN78L?? |
|----------------|-----------|------------|------------|-----------|---------|
| +2.6V | NJM78L02A | uA78L02ACL | uA78L26AWV | ----- | ----- |
| +4V | ----- | ----- | ----- | ----- | AN78L04 |
| +5V | NJM78L05A | uA78L05ACL | uA78L05AWV | uPC78L05J | AN78L05 |
| +6V | NJM78L06A | ----- | ----- | ----- | AN78L06 |
| +6.2V | ----- | uA78L06ACL | uA78L62AWV | ----- | ----- |
| +7V | ----- | ----- | ----- | ----- | AN78L07 |
| +8V | NJM78L08A | uA78L08ACL | ----- | uPC78L08J | AN78L08 |
| +8.2V | ----- | ----- | uA78L82AWV | ----- | ----- |
| +9V | NJM78L09A | uA78L09ACL | uA78L09AWV | ----- | AN78L09 |
| +10V | ----- | uA78L10ACL | ----- | uPC78L10J | AN78L10 |
| +12V | NJM78L12A | uA78L12ACL | uA78L12AWV | uPC78L12J | AN78L12 |
| +15V | NJM78L15A | uA78L15ACL | uA78L15AWV | uPC78L15J | AN78L15 |
| +18V | NJM78L18A | ----- | uA78L18AWV | ----- | AN78L18 |
| +20V | NJM78L20A | ----- | ----- | ----- | AN78L20 |
| +24V | NJM78L24A | ----- | uA78L24AWV | ----- | AN78L24 |

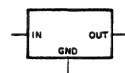

AN78M?? (MATSUSHITA)

FS78??M (SANKEN)
HA178M??P (HITACHI)
L78M?? (SANYO)
uA78M??UC (FSC)
uPC78M??H (NEC)
POSITIVE VOLTAGE REGULATOR (0.5A)
— SIDE VIEW —

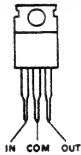

| OUTPUT VOLTAGE | uA78M??UC | FS78??M | uPC78M??H | L78M?? | HA178M??P |
|----------------|-----------|---------|-----------|--------|-----------|
| +5V | uA78M05UC | FS7805M | uPC78M05H | L78M05 | HA178M05P |
| +6V | uA78M06UC | ----- | ----- | ----- | HA178M06P |
| +7V | ----- | ----- | ----- | ----- | HA178M07P |
| +8V | uA78M08UC | ----- | uPC78M08H | ----- | HA178M08P |
| +12V | uA78M12UC | FS7812M | uPC78M12H | ----- | HA178M12P |
| +15V | uA78M15UC | FS7815M | uPC78M15H | ----- | HA178M15P |
| +18V | ----- | ----- | ----- | ----- | HA178M18P |
| +20V | uA78M20UC | ----- | ----- | ----- | HA178M20P |
| +24V | uA78M24UC | FS7824M | uPC78M24H | ----- | HA178M24P |

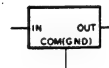

| OUTPUT VOLTAGE | AN78M?? |
|----------------|---------|
| +5V | AN78M05 |
| +6V | AN78M06 |
| +7V | AN78M07 |
| +8V | AN78M08 |
| +9V | AN78M09 |
| +10V | AN78M10 |
| +12V | AN78M12 |
| +15V | AN78M15 |
| +18V | AN78M18 |
| +20V | AN78M20 |
| +24V | AN78M24 |

AN79L?? (MATSUSHITA)

NEGATIVE VOLTAGE REGULATOR (100mA)
— FRONT VIEW —

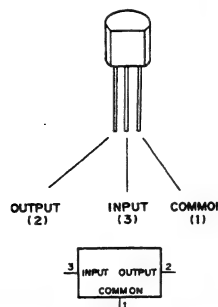

| OUTPUT VOLTAGE | ?? |
|----------------|----|
| -4V | 04 |
| -5V | 05 |
| -6V | 06 |
| -7V | 07 |
| -8V | 08 |
| -9V | 09 |
| -10V | 10 |
| -12V | 12 |
| -15V | 15 |
| -18V | 18 |
| -20V | 20 |
| -24V | 24 |

AN79M?? (MATSUSHITA)
 FS79??M (SANKEN)
 uA79M??AUC (FSC)
 uPC79M??H (NEC)
 NEGATIVE VOLTAGE REGULATOR (0.5A)
 — SIDE VIEW —

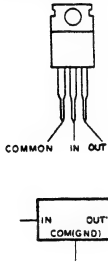

| OUTPUT VOLTAGE | uA79M??AUC | FS79??M | AN79M?? | uPC79M??H |
|----------------|------------|---------|---------|-----------|
| -5V | uA79M05AUC | FS7905M | AN79M05 | uPC79M05H |
| -6V | uA79M06AUC | | AN79M06 | |
| -7V | | | AN79M07 | |
| -8V | uA79M08AUC | | AN79M08 | uPC79M08H |
| -9V | | | AN79M09 | |
| -10V | | | AN79M10 | |
| -12V | uA79M12AUC | FS7912M | AN79M12 | uPC79M12H |
| -15V | uA79M15AUC | FS7915M | AN79M15 | uPC79M15H |
| -18V | | | AN79M18 | uPC79M18H |
| -20V | uA79M20AUC | | AN79M20 | |
| -24V | uA79M24AUC | FS7924M | AN79M24 | uPC79M24H |

BA4558 (ROHM)
 BA4558F (ROHM) FLAT PACKAGE
 HA17558 (HITACHI)
 M5218P (MITSUBISHI)
 NJM4558D (JRC)
 NJM4558D-D (JRC)
 NJM4558D-FA (JRC)
 NJM4558D-MD (JRC)
 NJM4558M (JRC) FLAT PACKAGE
 RC4558 (RAYTHEON)
 uPC4558C (NEC)
 uPC4558G (NEC) FLAT PACKAGE
 uPC4558G2 (NEC) FLAT PACKAGE
 OPERATIONAL AMPLIFIER
 — TOP VIEW —

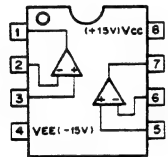

BA6993 (ROHM)
 IR9393 (SHARP)
 NJM2903D (JRC)
 NJM2903M (JRC) FLAT PACKAGE
 uA393DC (FSC)
 uPC393C (NEC)
 uPC393G (NEC) FLAT PACKAGE
 uPC393G2 (NEC) FLAT PACKAGE
 VOLTAGE COMPARATOR
 — TOP VIEW —

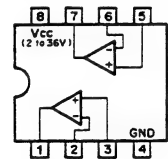

BA707 (ROHM)
 +3.3V VOLTAGE REGULATOR

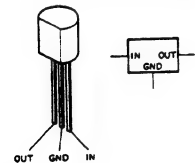

BX1281 (SONY)
 POWER MOS FET DRIVER
 — PRINTED SIDE VIEW —

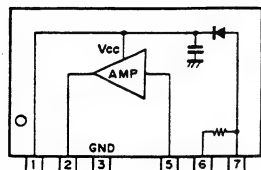

BX1320 (SONY)
 DRUM AND CAPSTAN MOTOR DRIVE CONTROLLER
 — PRINTED SIDE VIEW —

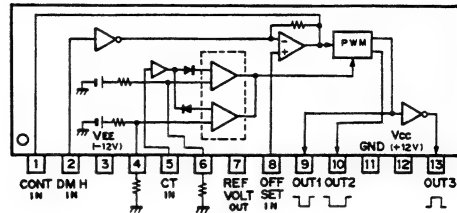

BX1321 (SONY)
 REEL MOTOR DRIVE CONTROLLER
 — PRINTED SIDE VIEW —

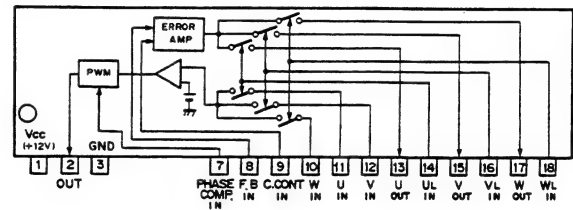

CD4001AE/BE (RCA)
 CD4001UBE (RCA)
 HD14001BP (HITACHI)
 MB84001B (FUJITSU)
 MC14001BCP (MOTOROLA)
 MC14001UBCP (MOTOROLA)
 MSM4001 (OKI)
 MSM4001BRS (OKI)
 TC4001BF (TOSHIBA) FLAT PACKAGE
 TC4001BP (TOSHIBA)
 TC4001UBP (TOSHIBA)
 uPD4001BC (NEC)
 C-MOS 2-INPUT NOR GATE
 — TOP VIEW —

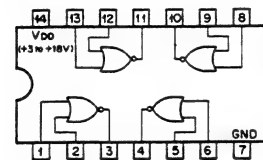

$$A \text{ --- } B \text{ --- } Y = A + B$$

$$Y = A + B = \overline{\overline{A} \cdot \overline{B}}$$

| A | B | Y |
|---|---|---|
| 0 | 0 | 1 |
| 0 | 1 | 0 |
| 1 | 0 | 0 |
| 1 | 1 | 0 |

0: LOW LEVEL
 1: HIGH LEVEL

CD4011AE/BE (RCA)
 CD4011UBE (RCA)
 HD14011BP (HITACHI)
 MB84011B (FUJITSU)
 MC14011BCP (MOTOROLA)
 MC14011UBCP (MOTOROLA)
 MSM4011BRS (OKI)
 MSM4011RS (OKI)
 TC4011BF (TOSHIBA) FLAT PACKAGE
 TC4011BP (TOSHIBA)
 TC4011UBP (TOSHIBA)
 uPD4011BC (NEC)
 C-MOS 2-INPUT NAND GATE
 — TOP VIEW —

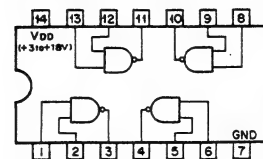

$$A \text{ --- } B \text{ --- } Y = A \cdot B$$

$$Y = A \cdot B = \overline{\overline{A} + \overline{B}}$$

| A | B | Y |
|---|---|---|
| 0 | 0 | 1 |
| 0 | 1 | 0 |
| 1 | 0 | 0 |
| 1 | 1 | 1 |

0: LOW LEVEL
 1: HIGH LEVEL

CD4013AE/BE (RCA)
 HD14013BFP (HITACHI) FLAT PACKAGE
 HD14013BP (HITACHI)
 MB84013B (FUJITSU)
 MB84013M (FUJITSU)
 MC14013BCP (MOTOROLA)
 uPD4013BC (NEC)
 uPD4013BG (NEC)
 uPD4013C (NEC)
 C-MOS D-TYPE FLIP-FLOP WITH DIRECT SET/RESET
 — TOP VIEW —

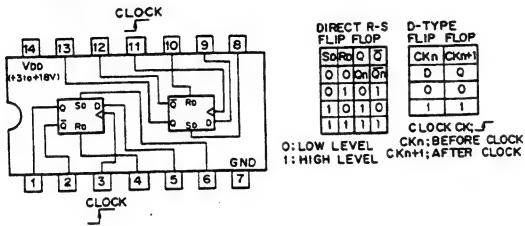

CD4046BE (RCA)
 HD14046BP (HITACHI)
 MC14046BCP (MOTOROLA)
 TC4046BP (TOSHIBA)
 C-MOS PHASE LOCKED LOOP
 — TOP VIEW —

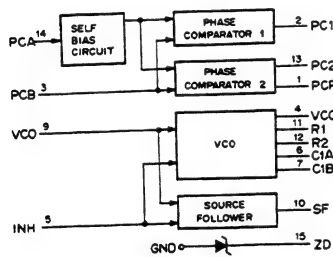
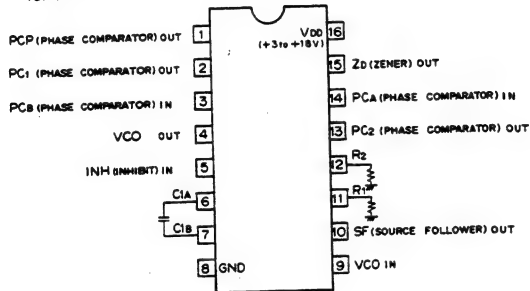

CD4049AE (RCA)
 CD4049UBE (RCA)
 HD14049UBP (HITACHI)
 M4049BP (MITSUBISHI)
 MB84049B (FUJITSU)
 MB84049UB (FUJITSU)
 MC14049BCP (MOTOROLA)
 MSM4049BRS (OKI)
 TC4049BF (TOSHIBA) FLAT PACKAGE
 TC4049BP (TOSHIBA)
 uPD4049C (NEC)
 uPD4049UBC (NEC)
 C-MOS INVERTING TYPE BUFFER/CONVERTER
 — TOP VIEW —

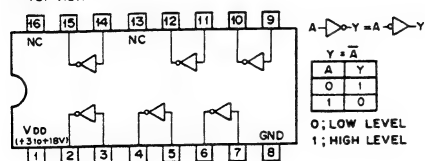

CD4051BE (RCA)
 F4051BPC (FSC)
 HD14051BP (HITACHI)
 MB84051B (FUJITSU)
 MC14051BCP (MOTOROLA)
 MSM4051BRS (OKI)
 TC4051BF (TOSHIBA) FLAT PACKAGE
 TC4051BP (TOSHIBA)
 TP4051B (TI)
 uPD4051BC (NEC)
 C-MOS 8-CHANNEL MULTIPLEXER/DEMULTIPLEXER
 — TOP VIEW —

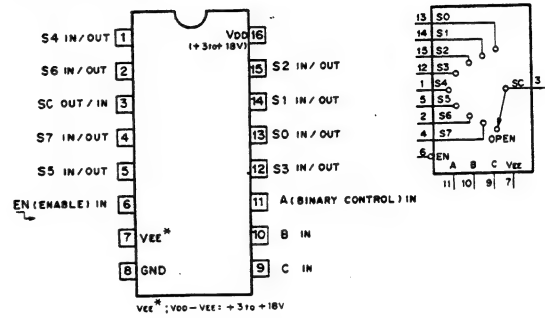

| EN | C | B | A | "ON" CHANNEL |
|----|---|---|---|--------------|
| 0 | 0 | 0 | 0 | 0 |
| 0 | 0 | 0 | 1 | 1 |
| 0 | 0 | 1 | 0 | 2 |
| 0 | 0 | 1 | 1 | 3 |
| 0 | 1 | 0 | 0 | 4 |
| 0 | 1 | 0 | 1 | 5 |
| 0 | 1 | 1 | 0 | 6 |
| 0 | 1 | 1 | 1 | 7 |
| 1 | X | X | X | OPEN |

0: LOW LEVEL
 1: HIGH LEVEL
 X: DON'T CARE

CD4052BE (RCA)
 HD14052BP (HITACHI)
 MB84052B (FUJITSU)
 MC14052BCP (MOTOROLA)
 MSM4052BRS (OKI)
 TC4052BF (TOSHIBA) FLAT PACKAGE
 TC4052BP (TOSHIBA)
 uPD4052BC (NEC)
 C-MOS 4-CHANNEL MULTIPLEXER/DEMULTIPLEXER
 — TOP VIEW —

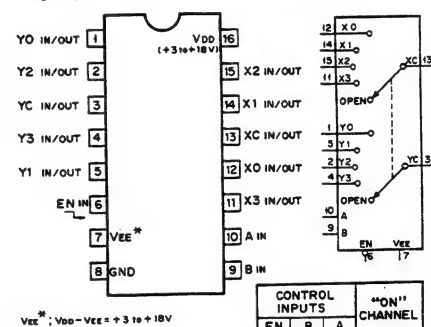

| CONTROL INPUTS | | | "ON" CHANNEL |
|----------------|---|---|--------------|
| EN | B | A | |
| 0 | 0 | 0 | 0 |
| 0 | 0 | 1 | 1 |
| 0 | 1 | 0 | 2 |
| 0 | 1 | 1 | 3 |
| 1 | X | X | OPEN |

0: LOW LEVEL
 1: HIGH LEVEL
 X: DON'T CARE

CD4053BE (RCA)
 HD14053BP (HITACHI)
 MB84053B (FUJITSU)
 MC14053BCP (MOTOROLA)
 MSM4053 (OKI)
 TC4053BF (TOSHIBA) FLAT PACKAGE
 TC4053BFHB (TOSHIBA)
 TC4053BP (TOSHIBA)
 uPD4053BC (NEC)
 uPD4053BG (NEC) FLAT PACKAGE
 C-MOS 2-CHANNEL MULTIPLEXER/DEMULTIPLEXER
 — TOP VIEW —

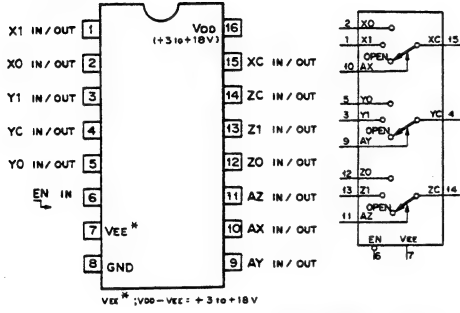

VEE* : VDD - VEE = +3 to +18 V

| CONT. INPUTS | | ON CHANNEL |
|--------------|-----------|------------|
| EN | A (X,Y,Z) | |
| 0 | 0 | 0 |
| 0 | 1 | 1 |
| 1 | X | OPEN |

0; LOW LEVEL
 1; HIGH LEVEL
 X; DON'T CARE.

CD4520BE (RCA)
 HD14520BP (HITACHI)
 MB84520B (FUJITSU)
 MC14520BCP (MOTOROLA)
 MSM4520BRS (OKI)
 MSM4520RS (OKI)
 TC4520BF (TOSHIBA) FLAT PACKAGE
 TC4520BP (TOSHIBA)
 uPD4520BC (NEC)
 C-MOS DUAL 4-BIT BINARY UP COUNTER
 — TOP VIEW —

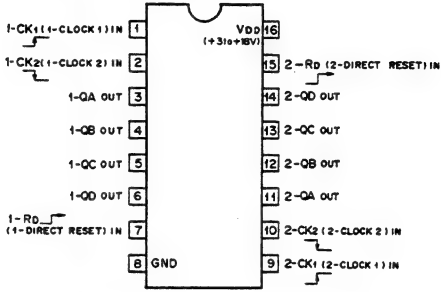

| STATE | OUTPUTS |
|-------|----------|
| | 2D CCBBA |
| 0 | 0 0 0 0 |
| 1 | 0 0 0 1 |
| 2 | 0 0 1 0 |
| 3 | 0 0 1 1 |
| 4 | 0 1 0 0 |
| 5 | 0 1 0 1 |
| 6 | 0 1 1 0 |
| 7 | 0 1 1 1 |
| 8 | 1 0 0 0 |
| 9 | 1 0 0 1 |
| 10 | 1 0 1 0 |
| 11 | 1 0 1 1 |
| 12 | 1 1 0 0 |
| 13 | 1 1 0 1 |
| 14 | 1 1 1 0 |
| 15 | 1 1 1 1 |

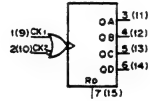

| CK1 | CK2 | Rd | ACTION |
|-----|-----|----|-------------------|
| F | 1 | 0 | INCREMENT COUNTER |
| 0 | 1 | 0 | INCREMENT COUNTER |
| 1 | X | 0 | NO CHANGE |
| X | F | 0 | NO CHANGE |
| F | 0 | 0 | NO CHANGE |
| 1 | 1 | 0 | NO CHANGE |
| X | X | 1 | QA THRU QD = 0 |

CD4516BE (RCA)
 HD14516BP (HITACHI)
 MC14516BCP (MOTOROLA)
 TC4516BF (TOSHIBA) FLAT PACKAGE
 TC4516BP (TOSHIBA)
 uPD4516BC (NEC)
 C-MOS PRESETTABLE BINARY UP/DOWN COUNTER
 — TOP VIEW —

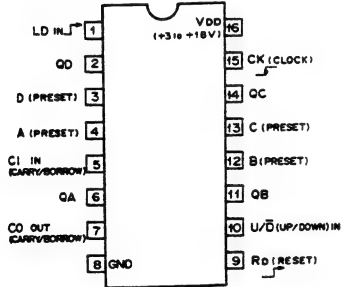

| INPUTS | | | | | OUTPUTS | | | |
|--------|----|----|----|-----|----------------|----|----|----|
| CK | Rd | LD | CI | U/D | QD | QC | QB | QA |
| X | 1 | X | X | X | 0 | 0 | 0 | 0 |
| X | 0 | 1 | X | X | SET TO A,B,C,D | | | |
| F | 0 | 0 | 0 | 1 | COUNT UP | | | |
| F | 0 | 0 | 0 | 0 | COUNT DOWN | | | |
| 0 | 0 | 0 | X | X | NO CHANGE | | | |
| X | 0 | 0 | 1 | X | NO CHANGE | | | |

| COUNT | OUTPUTS | | | |
|-------|---------|----|----|----|
| | QD | QC | QB | QA |
| 0 | 0 | 0 | 0 | 0 |
| 1 | 0 | 0 | 0 | 1 |
| 2 | 0 | 0 | 1 | 0 |
| 3 | 0 | 0 | 1 | 1 |
| 4 | 0 | 1 | 0 | 0 |
| 5 | 0 | 1 | 0 | 1 |
| 6 | 0 | 1 | 1 | 0 |
| 7 | 0 | 1 | 1 | 1 |
| 8 | 1 | 0 | 0 | 0 |
| 9 | 1 | 0 | 0 | 1 |
| 10 | 1 | 0 | 1 | 0 |
| 11 | 1 | 0 | 1 | 1 |
| 12 | 1 | 1 | 0 | 0 |
| 13 | 1 | 1 | 0 | 1 |
| 14 | 1 | 1 | 1 | 0 |
| 15 | 1 | 1 | 1 | 1 |

CO=L 8 (DOWN-COUNT "0" OR UP-COUNT "15")
 CI=L 8 (DOWN-COUNT "0" OR UP-COUNT "15")

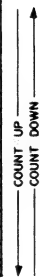

CD4556BE (RCA)
 HD14556BP (HITACHI)
 MC14556BCP (MOTOROLA)
 TC4556BF (TOSHIBA) FLAT PACKAGE
 TC4556BP (TOSHIBA)
 uPD4556BC (NEC)
 C-MOS BINARY TO 1-OF-4 DECODER/DEMULTIPLEXER
 — TOP VIEW —

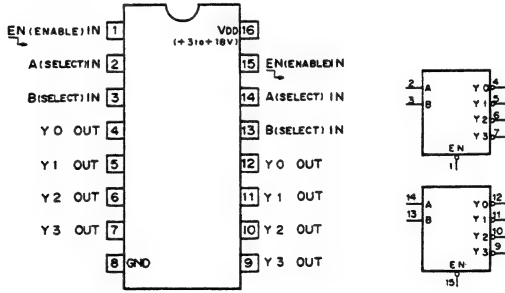

| INPUTS | | | OUTPUTS | | | |
|--------|---|---|---------|----|----|----|
| EN | A | B | Y3 | Y2 | Y1 | Y0 |
| 0 | 0 | 0 | 1 | 1 | 1 | 0 |
| 0 | 0 | 1 | 1 | 1 | 0 | 1 |
| 0 | 1 | 0 | 1 | 0 | 1 | 1 |
| 0 | 1 | 1 | 0 | 1 | 1 | 1 |
| 1 | X | X | 1 | 1 | 1 | 1 |

X; DON'T CARE
 1; HIGH LEVEL
 0; LOW LEVEL

CD74HC40105E (RCA)
C-MOS 16-WORDx4-BIT FIFO REGISTER
— TOP VIEW —

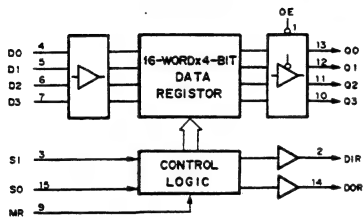
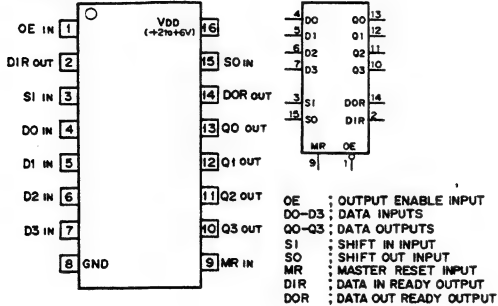

CF77074NT (TI)
CLOCK COUNTER
— TOP VIEW —

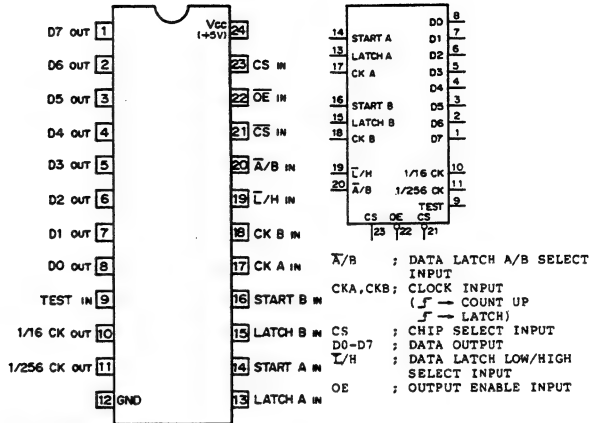

MODE SELECT

| INPUT | | | | | OUTPUT |
|-------|----|----|-----|-----|-------------------|
| CS | CS | OE | A/B | L/H | DO-D7 |
| 0 | X | X | X | X | HI-Z |
| 1 | 0 | 0 | 0 | 0 | LATCH A LOW BYTE |
| 1 | 0 | 0 | 0 | 1 | LATCH A HIGH BYTE |
| 1 | 0 | 0 | 1 | 0 | LATCH B LOW BYTE |
| 1 | 0 | 0 | 1 | 1 | LATCH B HIGH BYTE |
| X | 1 | X | X | X | HI-Z |
| X | X | 1 | X | X | HI-Z |

0: LOW LEVEL
1: HIGH LEVEL
X: DON'T CARE
HI-Z: HIGH IMPEDANCE

CX23026 (SONY)
C-MOS 8-BIT SERIAL TO/FROM PARALLEL SHIFT REGISTER
— TOP VIEW —

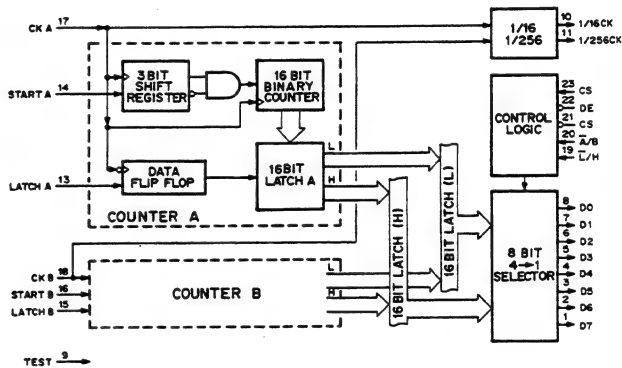
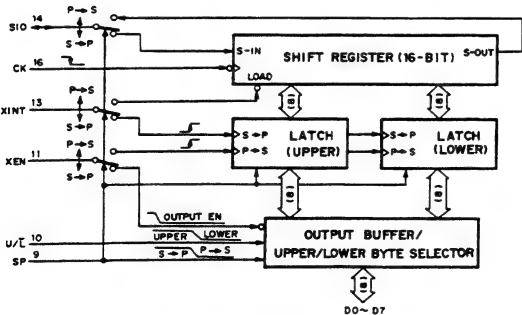
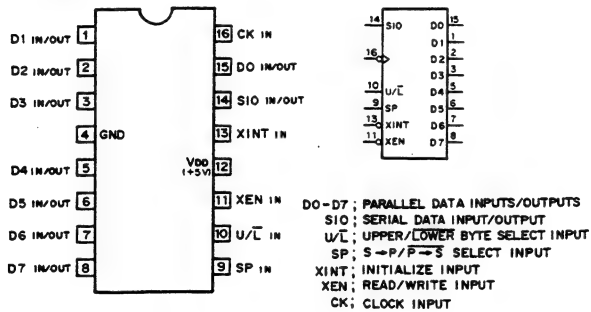



CX7907 (SONY)
 CX7907A (SONY)
 C-MOS TIME CODE GENERATOR
 - TOP VIEW -

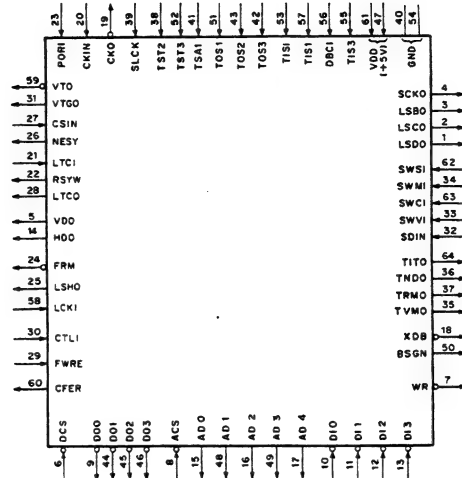
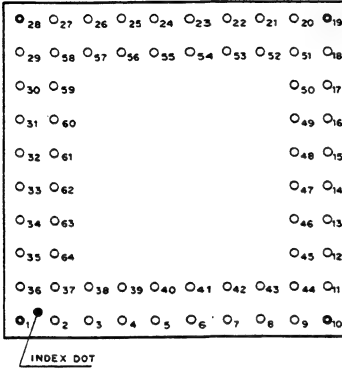

PIN ASSIGNMENT

| Pin No. | IN | OUT | SYMBOL | Pin No. | IN | OUT | SYMBOL | Pin No. | IN | OUT | SYMBOL | Pin No. | IN | OUT | SYMBOL |
|---------|----|-----|--------|---------|----|-----|--------|---------|----|-----|----------|---------|----|-----|----------|
| 1 | | o | LSDO | 17 | | o | AD4 | 33 | | o | SWVI | 49 | | o | AD3 |
| 2 | | o | LSCO | 18 | | o | XDB | 34 | | o | SWMI | 50 | | o | BSGN |
| 3 | | o | LSBO | 19 | | o | CKO | 35 | | o | TMDO | 51 | | o | TOS1 |
| 4 | | o | SCKO | 20 | | o | CKIN | 36 | | o | TMDO | 52 | | o | TST3 |
| 5 | | o | VDO | 21 | | o | LTCI | 37 | | o | TRMO | 53 | | o | TISI |
| 6 | o | | DCS | 22 | | o | RSYW | 38 | | o | TST2 | 54 | | o | GND |
| 7 | | o | WR | 23 | | o | PORI | 39 | | o | SLCK | 55 | | o | TIS3 |
| 8 | o | | ACS | 24 | | o | FRM | 40 | | o | GND | 56 | | o | DRCI |
| 9 | | o | DOO | 25 | | o | LSHO | 41 | | o | TSAI | 57 | | o | TIS1 |
| 10 | o | | DIO | 26 | | o | NESY | 42 | | o | TOS3 | 58 | | o | LCKI |
| 11 | o | | DI1 | 27 | | o | CSIN | 43 | | o | TOS2 | 59 | | o | LCKI |
| 12 | o | | DI2 | 28 | | o | LTCO | 44 | | o | DO1 | 60 | | o | CPER |
| 13 | o | | DI3 | 29 | | o | FWRE | 45 | | o | DO2 | 61 | | o | VDD(+5V) |
| 14 | | o | HDO | 30 | | o | CTLI | 46 | | o | DO3 | 62 | | o | SWSI |
| 15 | | o | ADO | 31 | | o | VTGO | 47 | | o | VDD(+5V) | 63 | | o | SWCI |
| 16 | | o | AD2 | 32 | | o | SDIN | 48 | | o | AD1 | 64 | | o | TITO |

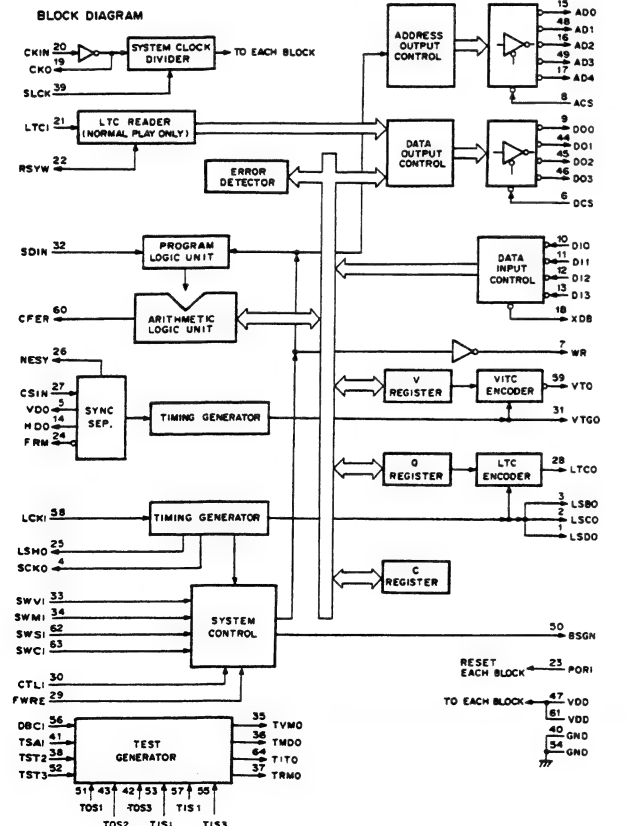

FUNCTIONAL PIN DEFINITION

| Pin No. | SYMBOL | DESCRIPTION |
|---------|--------|---|
| 8 | ACS | ADDRESS LINE CHIP SELECT INPUT |
| 15 | ADO | ADDRESS DATA OUTPUT |
| 16 | AD2 | ADDRESS DATA OUTPUT |
| 17 | AD4 | ADDRESS DATA OUTPUT |
| 49 | AD3 | ADDRESS DATA OUTPUT |
| 50 | BSGN | BUSY GENERATOR OUTPUT |
| 60 | CPER | COLOR FRAME ERROR FLAG OUTPUT |
| 20 | CKIN | SYSTEM CLOCK INPUT |
| 19 | CKO | CLOCK OUTPUT |
| 27 | CSIN | COMPOSITE SYNC INPUT |
| 30 | CTLI | CTL (TIMER) SIGNAL INPUT (T) |
| 6 | DCS | DATA LINE CHIP SELECT INPUT (NEGATIVE-LOGIC) |
| 10 | DIO | DATA BUS INPUT (NEGATIVE-LOGIC) |
| 11 | DI1 | DATA BUS INPUT (NEGATIVE-LOGIC) |
| 12 | DI2 | DATA BUS INPUT (NEGATIVE-LOGIC) |
| 13 | DI3 | DATA BUS INPUT (NEGATIVE-LOGIC) |
| 9 | DOO | DATA BUS OUTPUT (NEGATIVE-LOGIC) |
| 44 | DO1 | DATA BUS OUTPUT (NEGATIVE-LOGIC) |
| 45 | DO2 | DATA BUS OUTPUT (NEGATIVE-LOGIC) |
| 46 | DO3 | DATA BUS OUTPUT (NEGATIVE-LOGIC) |
| 24 | FRM | FRAME SIGNAL OUTPUT (NEGATIVE-LOGIC) |
| 29 | FWRE | CTL DIRECTION INPUT |
| 14 | HDO | HORIZONTAL SYNC DRIVE OUTPUT |
| 58 | LCKI | LTC CLOCK INPUT (SHMTE 9.6kHz/EBU 8kHz) |
| 3 | LSBO | LTC SYNCHRONOUS SIGNAL B OUTPUT |
| 2 | LSCO | LTC SYNCHRONOUS SIGNAL C OUTPUT |
| 1 | LSDO | LTC SYNCHRONOUS SIGNAL D OUTPUT |
| 25 | LSHO | LTC SYNCHRONOUS SIGNAL H OUTPUT |
| 21 | LTCI | LTC INPUT |
| 28 | LTCO | LTC SIGNAL OUTPUT |
| 26 | NESY | LOST-SYNC FLAG OUTPUT |
| 23 | PORI | POWER ON RESET INPUT |
| 22 | RSYW | READ SYNC WORD OUTPUT |
| 4 | SCKO | SWITCHES SIGNAL IN CLOCK OUTPUT |
| 32 | SDIN | SERIAL DATA INPUT |
| 39 | SLCK | SELECT CLOCK INPUT |
| 63 | SWCI | SWITCHES SIGNAL C INPUT |
| 34 | SWMI | SWITCHES SIGNAL M INPUT |
| 62 | SWSI | SWITCHES SIGNAL S INPUT |
| 33 | SWVI | SWITCHES SIGNAL V INPUT |
| 5 | VDO | VERTICAL SYNC DRIVE OUTPUT |
| 31 | VTGO | VITC GATE SIGNAL OUTPUT |
| 59 | VTO | VITC SIGNAL OUTPUT (NEGATIVE-LOGIC) |
| WR | WR | WRITE SIGNAL OUTPUT (NEGATIVE-LOGIC) |
| 18 | XDB | EXTERNAL DATA BUS IN FLAG OUTPUT (NEGATIVE-LOGIC) |
| 61 | VDD | POWER LINE (+5V) |
| 40 | GND | GND LINE |
| 54 | GND | GND LINE |
| 56 | DRCI | DRCI |
| 57 | TIS1 | TIS1 |
| 55 | TIS3 | TIS3 |
| 53 | TISI | TISI |
| 51 | TOS1 | TOS1 |
| 43 | TOS2 | TOS2 |
| 42 | TOS3 | TOS3 |
| 41 | TSAI | TSAI |
| 38 | TST2 | TST2 |
| 52 | TST3 | TST3 |
| 64 | TITO | TITO |
| 36 | TMDO | TMDO |
| 37 | TRMO | TRMO |
| 35 | TVMO | TVMO |

#32 SDIN

| LSDO | LSCO | LSBO | SWIN | FUNCTION |
|------|------|------|------|----------------------------|
| 0 | 0 | 0 | | INCREASE IN BIT 'PR OF D1' |
| 0 | 0 | 1 | | INCREASE IN BIT 'PT OF D2' |
| 0 | 1 | 0 | | INCREASE IN BIT 'SE OF D3' |
| 0 | 1 | 1 | | INCREASE IN BIT 'ST OF U4' |
| 1 | 0 | 0 | | INCREASE IN BIT 'MN OF U5' |
| 1 | 0 | 1 | | INCREASE IN BIT 'MT OF U6' |
| 1 | 1 | 0 | | INCREASE IN BIT 'RR OF U7' |
| 1 | 1 | 1 | | INCREASE IN BIT 'HT OF U8' |

NOTE: INFLUENCED BIT IS DECIDED BY FIRST 2 BITS OF SWCI.

#62 SWSI

| LSDO | LSCO | LSBO | SWSI | FUNCTION |
|------|------|------|-------|----------------------|
| 0 | 0 | 0 | FBS1* | VITC FIELD MARK/ |
| 0 | 0 | 1 | FBS2* | LTC PHASE CORRECTION |
| 0 | 1 | 0 | FBS3* | POSITION SELECT |
| 0 | 1 | 1 | 0 | PHASE CORRECTION ON |
| 0 | 1 | 1 | 1 | PHASE CORRECTION OFF |
| 1 | 0 | 0 | S1** | SIGNAL FORMAT |
| 1 | 0 | 1 | S2** | SELECT |
| 1 | 1 | 0 | S4** | |
| 1 | 1 | 1 | X | - |

NOTE: INFLUENCED BIT IS DECIDED BY FIRST 2 BITS OF SWCI.
X; DON'T CARE.

#63 SWCI

| LSDO | LSCO | LSBO | SWCI | FUNCTION |
|------|------|------|------|----------------------|
| 0 | 0 | 0 | 0 | U-BIT |
| 0 | 0 | 0 | 1 | TIME |
| 0 | 0 | 1 | 0 | CTL |
| 0 | 0 | 1 | 1 | TIME/U-BIT |
| 0 | 1 | 0 | X | - |
| 0 | 1 | 1 | 0 | DATA RESET ON*2 |
| 0 | 1 | 1 | 1 | DATA RESET OFF |
| 1 | 0 | 0 | 0 | TIME DATA HOLD |
| 1 | 0 | 0 | 1 | TIME DATA RUN |
| 1 | 0 | 1 | 1 | EXTERNAL DATA LOAD*2 |
| 1 | 1 | 0 | 0 | EXTRAPOLATION ON |
| 1 | 1 | 0 | 1 | EXTRAPOLATION OFF |
| 1 | 1 | 1 | X | - |

X; DON'T CARE.
*1; REFER TO TIMING CHART (DATA OUT).
*2; INFLUENCED DATA IS DECIDED BY FIRST 2 BITS OF SWCI.

#33 SWVI

| LSDO | LSCO | LSBO | SWVI | FUNCTION |
|------|------|------|------|----------------------|
| 0 | 0 | 0 | SW1A | VITC POSITION SELECT |
| 0 | 0 | 1 | SW1B | A |
| 0 | 1 | 0 | SW1C | |
| 0 | 1 | 1 | SW1D | |
| 1 | 0 | 0 | SW2A | VITC POSITION SELECT |
| 1 | 0 | 1 | SW2B | B |
| 1 | 1 | 0 | SW2C | |
| 1 | 1 | 1 | SW2D | |

*; VITC FIELD MARK/LTC PHASE CORRECTION POSITION SELECT

| FBS3 | FBS2 | FBS1 | FIELD MARK POSITION | LTC BIT No. |
|------|------|------|---------------------|-------------|
| 0 | 0 | 0 | AS1 | 10 |
| 0 | 0 | 1 | AS2 | 11 |
| 0 | 1 | 0 | AS3 | 27 |
| 0 | 1 | 1 | AS4 | 43 |
| 1 | 0 | 0 | AS5 | 58 |
| 1 | 0 | 1 | AS6 | 59 |
| 1 | 1 | 0 | - | - |
| 1 | 1 | 1 | - | - |

NOTE: LTC PHASE CORRECTION BIT OF CX7907 IS FIXED ON BIT-63.

**; SIGNAL FORMAT SELECT

| S4 | S2 | S1 | FORMAT | FRAME |
|----|----|----|-------------|-------|
| 0 | 0 | 0 | FLLM | 24 |
| 0 | 0 | 1 | NOT ALLOWED | - |
| 0 | 1 | X | - | - |
| 1 | 0 | 0 | PAL/SECAM | 25 |
| 1 | 0 | 1 | NOT ALLOWED | - |
| 1 | 1 | 0 | NTSC NDF | 30 |
| 1 | 1 | 1 | NTSC DF | 30 |

DF; DROP FRAME
NDF; NON DROP FRAME
X; DON'T CARE.

0; LOW LEVEL
1; HIGH LEVEL

†; VITC POSITION SELECT

| SW1D | SW1C | SW1B | SW1A | SW2D | SW2C | SW2B | SW2A | INSERTION LINE | |
|------|------|------|------|------|------|------|------|----------------|--------------|
| | | | | | | | | NTSC | PAL/SECAM |
| 0 | 0 | 0 | 0 | 0 | 0 | 0 | 0 | LINE 25 | LINE 22, 335 |
| 0 | 0 | 0 | 1 | 0 | 0 | 0 | 0 | 24 | 21, 334 |
| 0 | 0 | 0 | 1 | 1 | 0 | 0 | 0 | 21 | 20, 333 |
| 0 | 0 | 1 | 0 | 0 | 0 | 0 | 0 | 22 | 19, 332 |
| 0 | 0 | 1 | 0 | 1 | 0 | 0 | 0 | 21 | 18, 331 |
| 0 | 1 | 0 | 0 | 0 | 0 | 0 | 0 | 20 | 17, 330 |
| 0 | 1 | 0 | 1 | 0 | 0 | 0 | 0 | 19 | 16, 329 |
| 0 | 1 | 1 | 0 | 0 | 0 | 0 | 0 | 18 | 15, 328 |
| 1 | 0 | 0 | 0 | 0 | 0 | 0 | 0 | 17 | 14, 327 |
| 1 | 0 | 0 | 1 | 0 | 0 | 0 | 0 | 16 | 13, 326 |
| 1 | 0 | 1 | 0 | 0 | 0 | 0 | 0 | 15 | 12, 325 |
| 1 | 0 | 1 | 1 | 0 | 0 | 0 | 0 | 14 | 11, 324 |
| 1 | 1 | 0 | 0 | 0 | 0 | 0 | 0 | 13 | 10, 323 |
| 1 | 1 | 0 | 1 | 0 | 0 | 0 | 0 | 12 | 9, 322 |
| 1 | 1 | 1 | 0 | 0 | 0 | 0 | 0 | 11 | 8, 321 |
| 1 | 1 | 1 | 1 | 0 | 0 | 0 | 0 | 10 | 7, 320 |

#34 SWMI

| LSDO | LSCO | LSBO | SWMI | FUNCTION |
|------|------|------|------|--|
| 0 | 0 | 0 | X | INSERT SWMI DATA INTO BIT 'AS1' (NEGATIVE-LOGIC) |
| 0 | 0 | 1 | X | INSERT SWMI DATA INTO BIT 'AS2' (NEGATIVE-LOGIC) |
| 0 | 1 | 0 | X | INSERT SWMI DATA INTO BIT 'AS3' (NEGATIVE-LOGIC) |
| 0 | 1 | 1 | X | INSERT SWMI DATA INTO BIT 'AS4' (NEGATIVE-LOGIC) |
| 1 | 0 | 0 | X | INSERT SWMI DATA INTO BIT 'AS5' (NEGATIVE-LOGIC) |
| 1 | 0 | 1 | X | INSERT SWMI DATA INTO BIT 'AS6' (NEGATIVE-LOGIC) |
| 1 | 1 | 0 | 0 | COLOR FRAME LOCK IN FIELD 1 |
| 1 | 1 | 1 | 0 | COLOR FRAME OFF |
| 1 | 1 | 1 | 1 | COLOR FRAME ON |

X; DON'T CARE.

ERROR BYPASS ALGORITHM

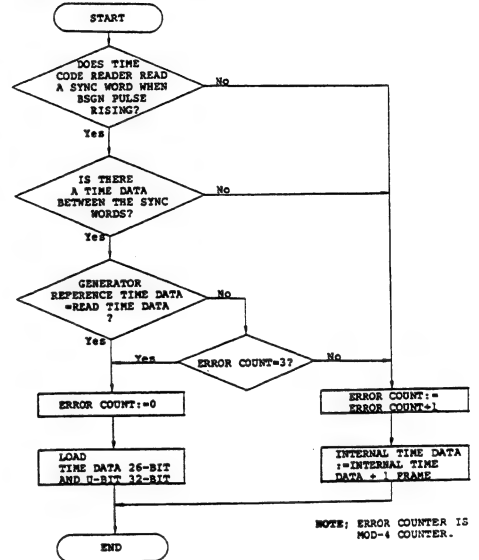

TIMING CHART

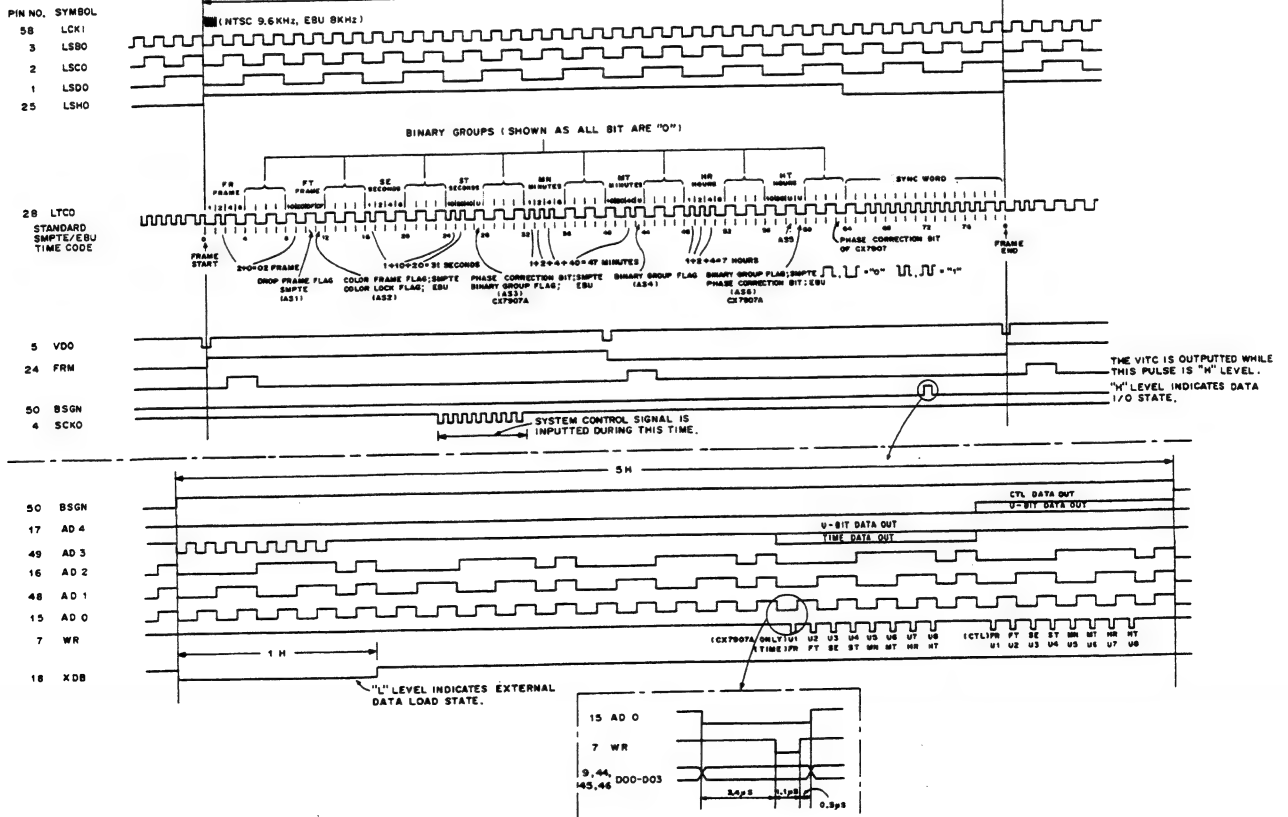

CX7912 (SONY)
CX7912A (SONY)
C-MOS TIME CODE READER
— TOP VIEW —

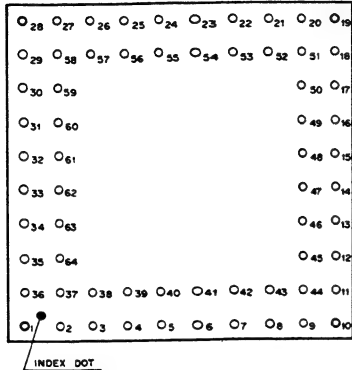

PIN ASSIGNMENT

| PIN NO. | IN | OUT | SYMBOL | PIN NO. | IN | OUT | SYMBOL | PIN NO. | IN | OUT | SYMBOL |
|---------|----|-------|--------|---------|-------|-----|--------|---------|----|-----|--------|
| 1 | ○ | S1 | 17 | ○ | AD 4 | 33 | ○ | SLCT | 49 | ○ | AD 3 |
| 2 | ○ | RST1 | 18 | ○ | RDSY | 34 | ○ | OU5 | 50 | ○ | BSRL |
| 3 | ○ | DER | 19 | ○ | CK 0 | 35 | ○ | S4 | 51 | ○ | TCT |
| 4 | ○ | BER | 20 | ○ | CK IN | 36 | ○ | S2 | 52 | ○ | SCK1 |
| 5 | ○ | FWRE | 21 | ○ | SCK0 | 37 | ○ | TSG 1 | 53 | ○ | TMO |
| 6 | ○ | DCS | 22 | ○ | DMSS | 38 | ○ | TSG 2 | 54 | ○ | GND |
| 7 | ○ | WR | 23 | ○ | PN | 39 | ○ | TSG 3 | 55 | ○ | XPN |
| 8 | ○ | ACS | 24 | ○ | PND | 40 | ○ | GND | 56 | ○ | AS6 |
| 9 | ○ | DD 0 | 25 | ○ | AS5 | 41 | ○ | H 4 0 | 57 | ○ | AS4 |
| 10 | ○ | CFS A | 26 | ○ | AS3 | 42 | ○ | H 8 0 | 58 | ○ | AS2 |
| 11 | ○ | CFS B | 27 | ○ | AS1 | 43 | ○ | H 16 0 | 59 | ○ | DCLK |
| 12 | ○ | CFS C | 28 | ○ | DATA | 44 | ○ | DD 1 | 60 | ○ | CAL |
| 13 | ○ | CFS D | 29 | ○ | FRE | 45 | ○ | DD 2 | 61 | ○ | VDDH5V |
| 14 | ○ | FLD | 30 | ○ | CTL 1 | 46 | ○ | DD 3 | 62 | ○ | SLTC |
| 15 | ○ | AD 0 | 31 | ○ | TC IN | 47 | ○ | VDDH5V | 63 | ○ | TPN |
| 16 | ○ | AD 2 | 32 | ○ | OVF | 48 | ○ | AD 1 | 64 | ○ | TEST |

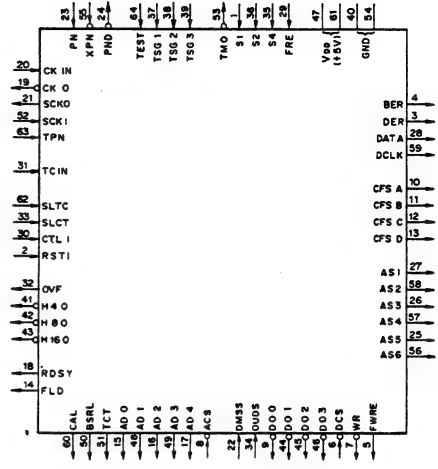

MODE SELECT

| SLCT | SLTC | MODE |
|------|------|-----------|
| 0 | 0 | AUTO |
| 0 | 1 | TIME CODE |
| 1 | 0 | CTL |
| 1 | 1 | AUTO |

CTL COUNT

| FRE | RST1 | COUNT |
|-----|------|------------|
| 0 | X | DOWN COUNT |
| 1 | X | UP COUNT |
| X | L | RESET |

SIGNAL FORMAT SELECT

| S4 | S2 | S1 | FORMAT | FRAME |
|----|----|----|-----------------------|-------|
| 0 | 0 | 0 | FILM | 24 |
| 0 | 0 | 1 | | |
| 0 | 1 | 0 | NOT ALLOWED | — |
| 0 | 1 | 1 | | |
| 1 | 0 | 0 | PAL, SECAM | 25 |
| 1 | 0 | 1 | NOT ALLOWED | — |
| 1 | 1 | 0 | NTSC (NON DROP FRAME) | 30 |
| 1 | 1 | 1 | NTSC (DROP FRAME) | 30 |

0: LOW LEVEL
1: HIGH LEVEL
X: DON'T CARE

TIMING CHART

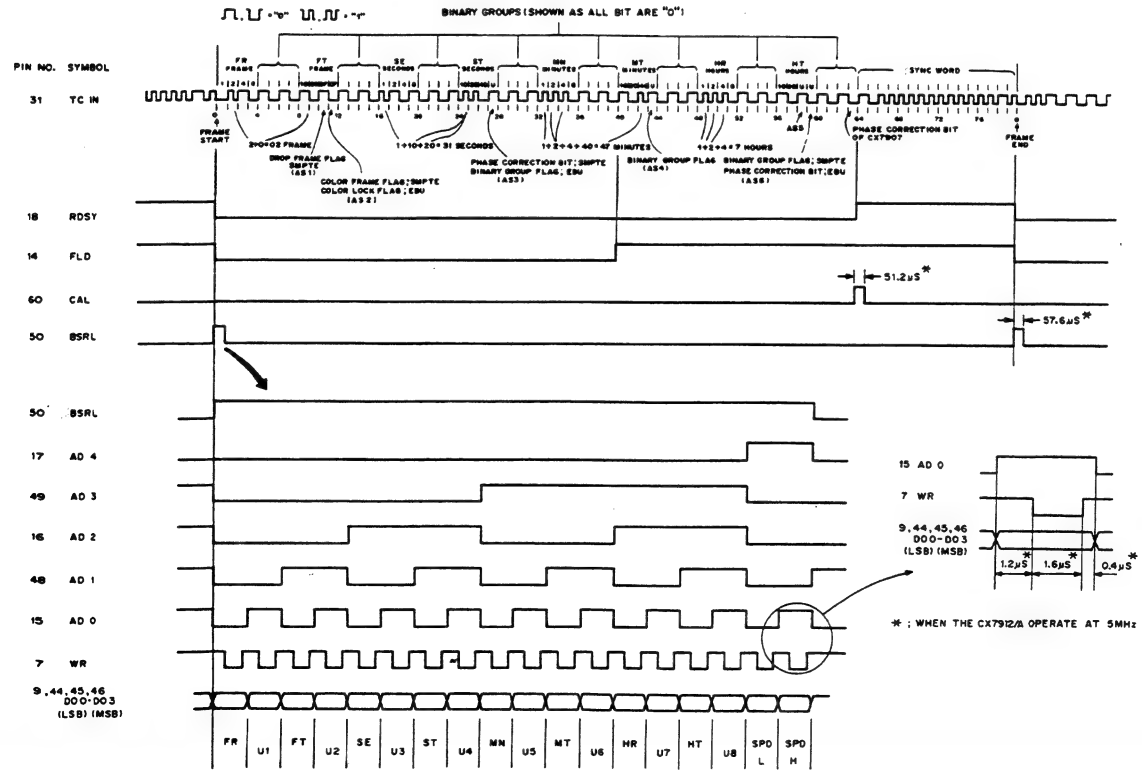

* : WHEN THE CX7912A OPERATE AT 5MHz

BLOCK DIAGRAM

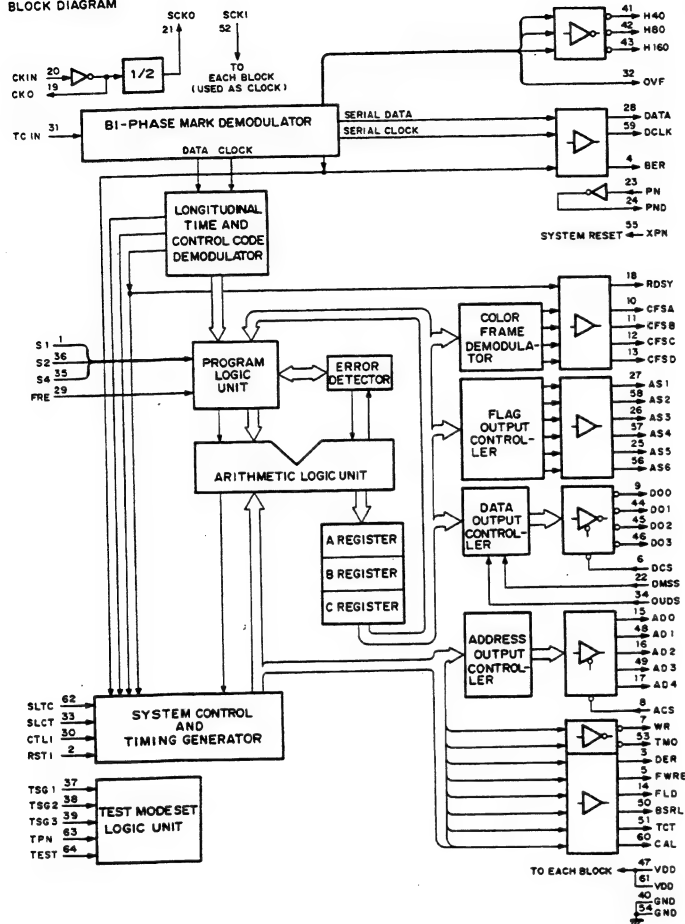

FUNCTIONAL PIN DEFINITION

| Pin No. | SYMBOL | DESCRIPTION |
|---------|--------|--|
| 8 | ACS | ADDRESS LINE OUTPUT ENABLE (NEGATIVE-LOGIC) |
| 15 | AD0 | |
| 48 | AD1 | |
| 16 | AD2 | |
| 49 | AD3 | ADDRESS DATA OUTPUT |
| 17 | AD4 | |
| 27 | AS1 | |
| 58 | AS2 | |
| 26 | AS3 | PARALLEL DATA OUTPUT |
| 57 | AS4 | |
| 25 | AS5 | |
| 56 | AS6 | |
| 4 | BER | BI-PHASE MARK ERROR (BIT ERROR) OUTPUT |
| 23 | PN | |
| 50 | BSRL | DATA OUT FLAG OUTPUT |
| 60 | CAL | CALCULATE OUT FLAG OUTPUT |
| 19 | CFSB | DEMODULATED COLOR FRAME OUTPUT |
| 11 | CFS8 | |
| 12 | CFS4 | |
| 13 | CFS0 | |
| 18 | RDSY | CLOCK INPUT |
| 19 | CKO | CLOCK OUTPUT (NEGATIVE-LOGIC) |
| 30 | CTLI | CTL SIGNAL INPUT (L) |
| 10 | DATA | DEMODULATED SERIAL DATA OUTPUT |
| 59 | DCLK | DEMODULATED CLOCK OUTPUT |
| 6 | DCS | DATA LINE OUTPUT ENABLE (NEGATIVE-LOGIC) |
| 3 | DER | DEMULATE DATA ERROR OUTPUT |
| 22 | DMSS | ASSIGNED DATA SELECT |
| 9 | DO0 | DATA OUTPUT (NEGATIVE-LOGIC) |
| 44 | DO1 | |
| 45 | DO2 | |
| 46 | DO3 | |
| 14 | FLD | FIELD DATA OUTPUT |
| 14 | PRE | CTL DIRECTION SIGNAL INPUT |
| 29 | FWRE | DEMULATE DIRECTION SIGNAL OUTPUT |
| 41 | H40 | SPEED RANGE FLAG 4 OUTPUT (NEGATIVE-LOGIC) |
| 42 | H80 | SPEED RANGE FLAG 8 OUTPUT (NEGATIVE-LOGIC) |
| 43 | H160 | SPEED RANGE FLAG 16 OUTPUT (NEGATIVE-LOGIC) |
| 34 | OUDS | ERROR BYPASS ON/OFF SELECT |
| 12 | OVF | OVERFLOW FLAG OUTPUT |
| 23 | PN | POWER ON SIGNAL INPUT |
| 24 | PND | POWER ON SIGNAL OUTPUT (NEGATIVE-LOGIC) |
| 18 | RDSY | READ SYNC WORD DATA OUTPUT |
| 2 | RSTI | CTL TIMER RESET INPUT (L) |
| 1 | S1 | SIGNAL FORMAT SELECT S1 |
| 36 | S2 | SIGNAL FORMAT SELECT S2 |
| 35 | S4 | SIGNAL FORMAT SELECT S4 |
| 52 | SCKI | SYSTEM CLOCK INPUT |
| 21 | SCKO | SYSTEM CLOCK OUTPUT |
| 33 | SLTC | SELECT CTL INPUT |
| 62 | SLTC | SELECT LTC INPUT |
| 55 | XPN | SYSTEM RESET SIGNAL INPUT (NEGATIVE-LOGIC) |
| 31 | TCIN | LONGITUDINAL TIME AND CONTROL CODE INPUT |
| 51 | TCT | INPUT SELECT FLAG OUTPUT |
| 53 | TMO | TIME OVER SIGNAL OUTPUT (NEGATIVE-LOGIC) |
| 7 | WR | WRITE SIGNAL OUTPUT (NEGATIVE-LOGIC) |
| 47 | VDD | POWER LINE (+5V) |
| 61 | VDD | |
| 40 | GND | GND LINE |
| 54 | GND | |
| 64 | TEST | TEST MODE SET INPUT (TO BE CONNECTED WITH GND) |
| 63 | TPN | |
| 37 | TSG1 | |
| 38 | TSG2 | |
| 39 | TSG3 | |

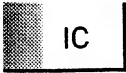

CX23028 (SONY)
 C-MOS SYNCHRONOUS ROTATIONAL DIRECTION DETECTOR
 - TOP VIEW -

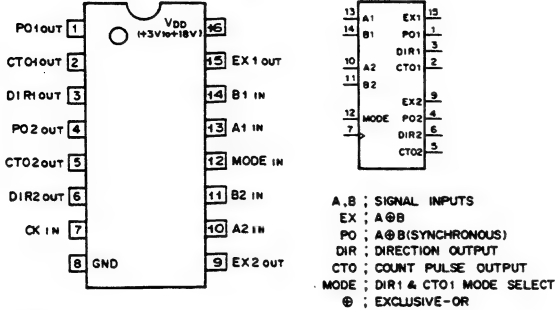

MODE = "1"

| DIRECTION OUTPUT "DIR" | |
|------------------------|-----|
| INPUTS | DIR |
| A < B | 1 |
| B < A | 0 |

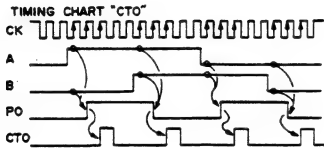

MODE = "0"

| DIRECTION OUTPUT "DIR" | | |
|------------------------|---------|--|
| CH1 | CH2 | DIR 1 |
| A1 < B1 | A2 < B2 | 1 |
| B1 < A1 | A2 < B2 | OUTPUT "1" AND "0" THE SAME FUNCTION OF MODE "1" |
| A1 < B1 | B2 < A2 | |
| B1 < A1 | B2 < A2 | 0 |

CTO 1 : CTO 1 with MODE "0" = CTO 1 with MODE "1" + CTO 2
 CTO 2 : THE SAME FUNCTION OF MODE "1"

1 : HIGH LEVEL
 0 : LOW LEVEL
 A < B : THE PHASE OF SIGNAL A IS IN ADVANCE FOR THE PHASE OF B.

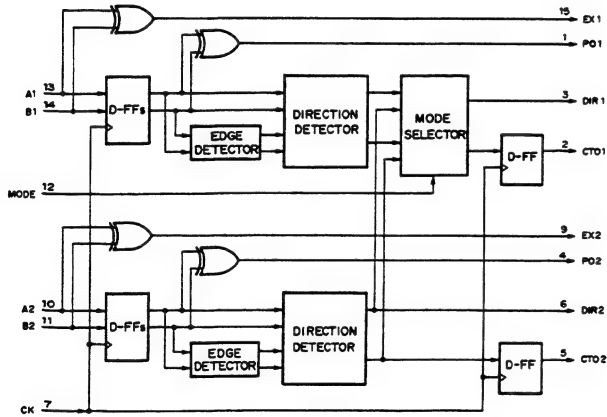

CXD1095Q (SONY) FLAT PACKAGE
C-MOS I/O PORT EXPANDER
— TOP VIEW —

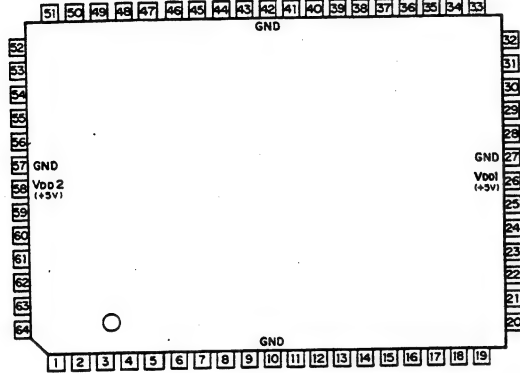

| PIN NO. | IN | OUT | SYMBOL | PIN NO. | IN | OUT | SYMBOL | PIN NO. | IN | OUT | SYMBOL | PIN NO. | IN | OUT | SYMBOL |
|---------|----|-----|--------|---------|----|-----|----------|---------|----|-----|--------|---------|----|-----|----------|
| 1 | | | NC | 17 | O | O | PC6 | 33 | | | NC | 49 | O | O | PX0 |
| 2 | | | NC | 18 | O | O | PC7 | 34 | | | NC | 50 | O | O | PX1 |
| 3 | O | O | PB1 | 19 | | | NC | 35 | O | O | D3 | 51 | | | NC |
| 4 | O | O | PB2 | 20 | O | O | P00 | 36 | O | O | D4 | 52 | O | O | PX2 |
| 5 | O | O | PB3 | 21 | O | O | P01 | 37 | O | O | D5 | 53 | O | O | PX3 |
| 6 | O | O | PB4 | 22 | O | O | P02 | 38 | O | O | D6 | 54 | O | O | PA0 |
| 7 | O | O | PB5 | 23 | O | O | P03 | 39 | O | O | D7 | 55 | O | O | PA1 |
| 8 | O | O | PB6 | 24 | O | O | PD4 | 40 | O | | CLR | 56 | O | O | PA2 |
| 9 | O | O | PB7 | 25 | | | GND | 41 | O | | RST | 57 | | | GND |
| 10 | | | GND | 26 | O | | VDD(+3V) | 42 | | | GND | 58 | O | | VDD(+3V) |
| 11 | O | O | PC0 | 27 | O | O | P05 | 43 | O | | WR | 59 | O | O | PA3 |
| 12 | O | O | PC1 | 28 | O | O | P06 | 44 | O | | RD | 60 | O | O | PA4 |
| 13 | O | O | PC2 | 29 | O | O | P07 | 45 | O | | CS | 61 | O | O | PA5 |
| 14 | O | O | PC3 | 30 | O | O | D0 | 46 | O | | A0 | 62 | O | O | PA6 |
| 15 | O | O | PC4 | 31 | O | O | D1 | 47 | O | | A1 | 63 | O | O | PA7 |
| 16 | O | O | PC5 | 32 | O | O | D2 | 48 | O | | A2 | 64 | O | O | PB0 |

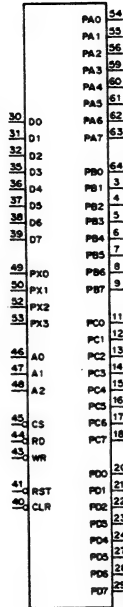

| CS | RD | WR | A2 | A1 | A0 | MODE |
|----|----|----|----|----|----|----------------------|
| 0 | 0 | 1 | 0 | 0 | 0 | PORT A → DATA BUS |
| 0 | 0 | 1 | 0 | 0 | 1 | PORT B → DATA BUS |
| 0 | 0 | 1 | 0 | 1 | 0 | PORT C → DATA BUS |
| 0 | 0 | 1 | 0 | 1 | 1 | PORT D → DATA BUS |
| 0 | 0 | 1 | 1 | 0 | 0 | PORT X → DATA BUS |
| 0 | 0 | 1 | 1 | 0 | 1 | --- |
| 0 | 0 | 1 | 1 | 1 | 0 | --- |
| 0 | 0 | 1 | 1 | 1 | 1 | --- |
| 0 | 1 | 0 | 0 | 0 | 0 | DATA BUS → PORT A |
| 0 | 1 | 0 | 0 | 0 | 1 | DATA BUS → PORT B |
| 0 | 1 | 0 | 0 | 1 | 0 | DATA BUS → PORT C |
| 0 | 1 | 0 | 0 | 1 | 1 | DATA BUS → PORT D |
| 0 | 1 | 0 | 1 | 0 | 0 | DATA BUS → PORT X |
| 0 | 1 | 0 | 1 | 0 | 1 | --- |
| 0 | 1 | 0 | 1 | 1 | 0 | DATA BUS → CTL REG.1 |
| 0 | 1 | 0 | 1 | 1 | 1 | DATA BUS → CTL REG.2 |
| 1 | X | X | X | X | X | DATA BUS ; HI-Z |

0; LOW LEVEL
1; HIGH LEVEL
X; DON'T CARE
HI-Z; HIGH IMPEDANCE

D0-D7; DATA BUS INPUTS/OUTPUTS
CS; CHIP SELECT INPUT
RD; READ STROBE INPUT
WR; WRITE STROBE INPUT
A0-A2; ADDRESS INPUT
RST; RESET INPUT
CLR; CLEAR INPUT
PA0-PA7; PORT A INPUTS/OUTPUTS
PB0-PB7; PORT B INPUTS/OUTPUTS
PC0-PC7; PORT C INPUTS/OUTPUTS
PD0-PD7; PORT D INPUTS/OUTPUTS
PX0-PX3; PORT X INPUTS/OUTPUTS

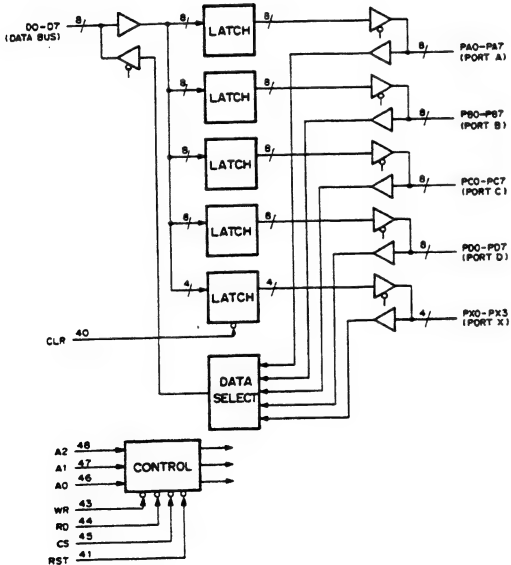

CXD1102Q (SONY) FLAT PACKAGE
C-MOS EL DISPLAY UNIT CONTROLLER
- TOP VIEW -

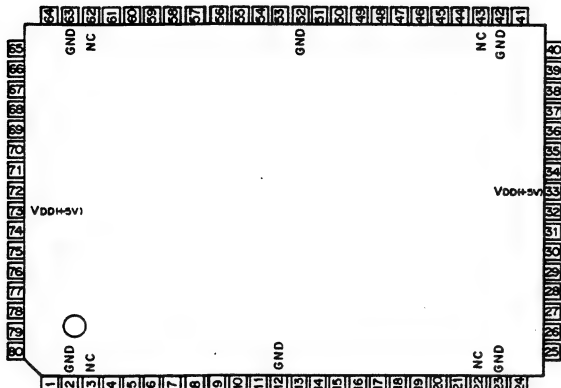

| PIN NO. | I/O | SYMBOL | PIN NO. | I/O | SYMBOL | PIN NO. | I/O | SYMBOL | PIN NO. | I/O | SYMBOL | | | |
|---------|-----|--------|---------|-----|--------|---------|-----|--------|---------|-----|--------|----|-----|-------|
| 1 | I/O | AD0 4 | 17 | O | MA0 2 | 33 | | VDD | 49 | I/O | MD0 1 | 65 | I | RAS |
| 2 | | GND | 18 | O | MA0 3 | 34 | I/O | MD1 4 | 50 | I/O | MD0 0 | 66 | I | HSYN |
| 3 | | NC | 19 | O | MA0 4 | 35 | I/O | MD1 3 | 51 | I | TEST1 | 67 | I | VSYN |
| 4 | I/O | AD0 3 | 20 | O | MA0 5 | 36 | I/O | MD1 2 | 52 | | GND | 68 | I | BLK |
| 5 | I/O | AD0 2 | 21 | O | MA0 6 | 37 | I/O | MD1 1 | 53 | I | CK | 69 | I/O | AD1 5 |
| 6 | I/O | AD0 1 | 22 | | NC | 38 | I/O | MD1 0 | 54 | I | TEST2 | 70 | I/O | AD1 4 |
| 7 | I/O | AD0 0 | 23 | | GND | 39 | I/O | MD0 9 | 55 | I | VDC2 | 71 | I/O | AD1 3 |
| 8 | I | WPI 1 | 24 | O | MA0 7 | 40 | I/O | MD0 8 | 56 | I | VDC1 | 72 | I/O | AD1 2 |
| 9 | I | WPI 2 | 25 | O | MA0 8 | 41 | I/O | MD0 7 | 57 | I | VDC0 | 73 | | VDD |
| 10 | O | WPO | 26 | O | MA0 9 | 42 | | GND | 58 | O | VD | 74 | I/O | AD1 1 |
| 11 | O | MWE | 27 | O | MA1 0 | 43 | | NC | 59 | O | HD | 75 | I/O | AD1 0 |
| 12 | | GND | 28 | O | MA1 1 | 44 | I/O | MD0 6 | 60 | O | DIN | 76 | I/O | AD0 9 |
| 13 | O | MCE | 29 | O | MA1 2 | 45 | I/O | MD0 5 | 61 | I | DBIN | 77 | I/O | AD0 8 |
| 14 | O | MOE | 30 | O | MA1 3 | 46 | I/O | MD0 4 | 62 | | NC | 78 | I/O | AD0 7 |
| 15 | O | MA0 0 | 31 | O | MA1 4 | 47 | I/O | MD0 3 | 63 | | GND | 79 | I/O | AD0 6 |
| 16 | O | MA0 1 | 32 | I/O | MA1 5 | 48 | I/O | MD0 2 | 64 | O | CKX2 | 80 | I/O | AD0 5 |

MA00-MA14: MEMORY ADDRESS OUTPUTS
MD00-MD15: MEMORY DATA INPUTS/OUTPUTS
AD00-AD15: MEMORY ADDRESS INPUTS/
MEMORY DATA INPUTS/OUTPUTS

CKX2: 1/2 CK OUTPUT
RAS: READ ENABLE INPUT
DBIN: WRITE ENABLE INPUT
HSYN: H COUNTER START PULSE INPUT
VSYN: V COUNTER START PULSE INPUT

MCE: MEMORY CHIP ENABLE INPUT
MOE: MEMORY OUTPUT ENABLE INPUT
MWE: MEMORY WRITE ENABLE INPUT
WPO: WRITE MODE OUTPUT
WPI1, WPI2: DELAYED WPO INPUTS

DIN: DISPLAY DATA OUTPUT
HD: DISPLAY H SYNC OUT
VD: DISPLAY V SYNC OUT

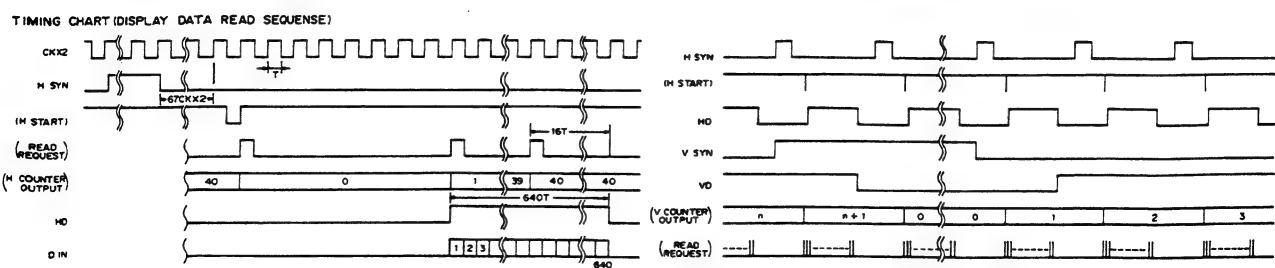
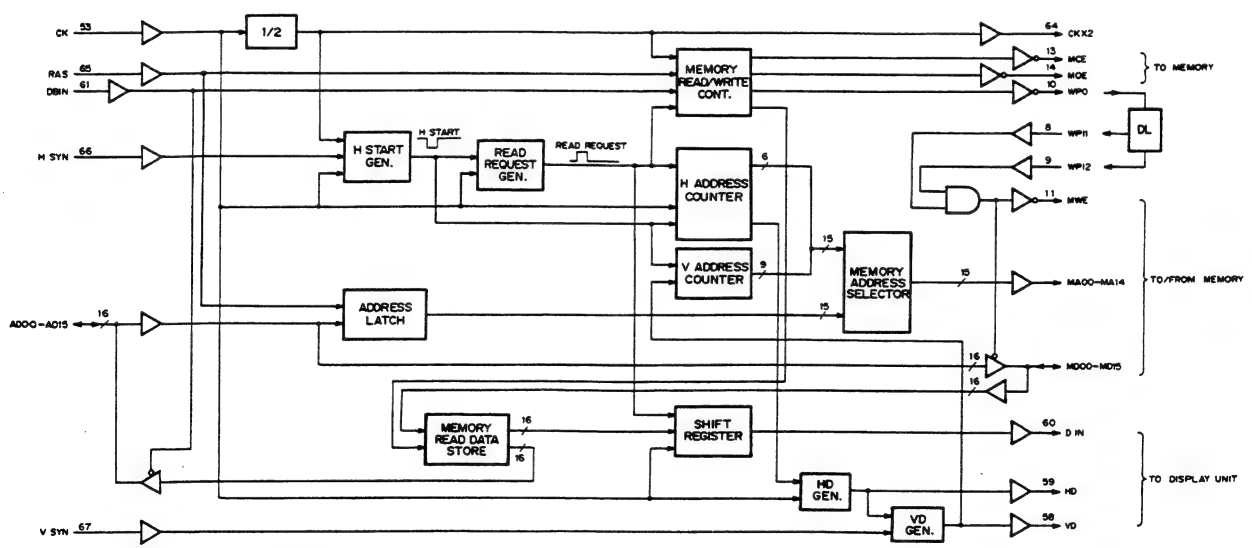
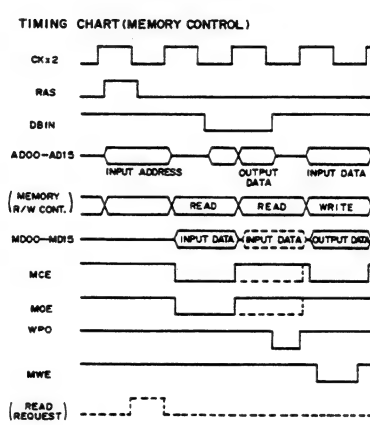
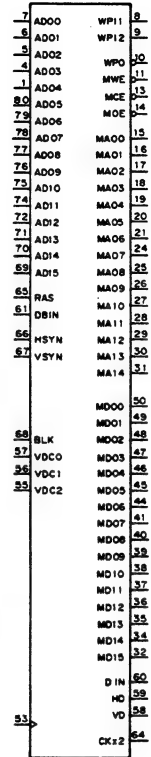

- CXK5864PN-15 (SONY) (ACCESS TIME = 150 nS)
- CXK5864PN-15L (SONY) (ACCESS TIME = 150 nS)
- HM6264LFP-15 (HITACHI) (ACCESS TIME = 150 nS) FLAT PACKAGE
- HM6264LFP-15T (HITACHI) (ACCESS TIME = 150 nS) FLAT PACKAGE
- HM6264LP-12 (HITACHI) (ACCESS TIME = 120 nS)
- HM6264LP-15 (HITACHI) (ACCESS TIME = 150 nS)
- HM6264P-12 (HITACHI) (ACCESS TIME = 120 nS)
- HM6264P-15 (HITACHI) (ACCESS TIME = 150 nS)
- TC5565P-15 (TOSHIBA) (ACCESS TIME = 150 nS)
- TC5565PL-12 (TOSHIBA) (ACCESS TIME = 120 nS)
- TC5565PL-15 (TOSHIBA) (ACCESS TIME = 150 nS)
- uPD4364C-15 (NEC) (ACCESS TIME = 150 nS)
- uPD4364C-15L (NEC) (ACCESS TIME = 150nS)
- uPD4364C-15L (NEC) (ACCESS TIME = 150nS) FLAT PACKAGE
- uPD4464C-15 (NEC) (ACCESS TIME = 150nS)
- uPD4464C-20 (NEC) (ACCESS TIME = 200nS)
- C-MOS 8192 WORDx8-BIT RAM

— TOP VIEW —

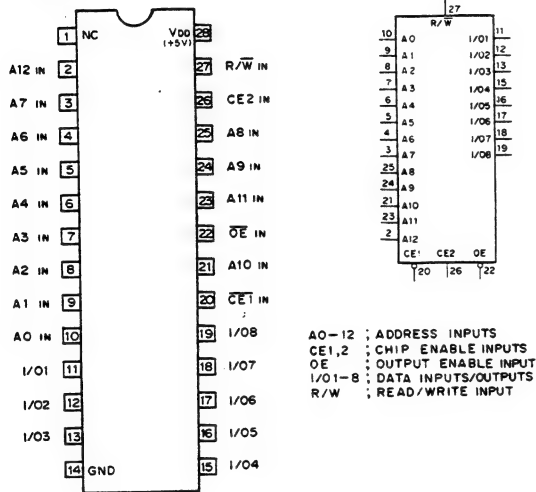

A0-12 : ADDRESS INPUTS
 CE1,2 : CHIP ENABLE INPUTS
 OE : OUTPUT ENABLE INPUT
 I/O1-8 : DATA INPUTS/OUTPUTS
 R/W : READ/WRITE INPUT

| MODE | CE1 | CE2 | OE | R/W | I/O1~8 |
|-----------------|-----|-----|----|-----|--------------|
| READ | 0 | 1 | 0 | 1 | DATA OUTPUTS |
| WRITE | 0 | 1 | X | 0 | DATA INPUTS |
| OUTPUT DESELECT | 0 | 1 | 1 | 1 | HI-Z |
| STANDBY | 1 | X | X | X | HI-Z |
| | X | 0 | X | X | HI-Z |

0 : LOW LEVEL
 1 : HIGH LEVEL
 X : DON'T CARE
 HI-Z : HIGH IMPEDANCE

- CXQ71011P (SONY)
- uPD71011C (NEC)
- C-MOS CLOCK PULSE GENERATOR/DRIVER

— TOP VIEW —

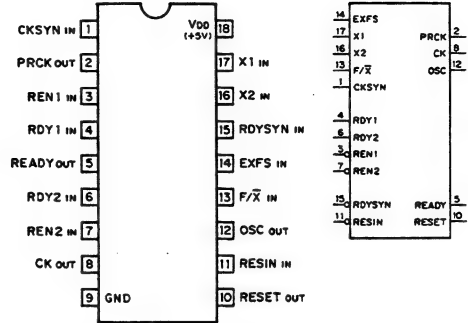

X1, X2 : CRYSTAL INPUT
 EXFS : EXTERNAL FREQUENCY SOURCE INPUT
 F/X : FREQUENCY/CRYSTAL SELECT INPUT
 CK : PROCESSOR CLOCK OUTPUT
 PRCK : PERIPHERAL CLOCK OUTPUT
 OSC : OSCILLATOR OUTPUT
 CKSYN : CLOCK SYNCHRONIZATION INPUT
 RESIN : RESET INPUT
 RDY1, RDY2 : BUS READY INPUT
 REN1, REN2 : READY ENABLE INPUT
 RDYSYN : READY SYNCHRONIZATION SELECT INPUT

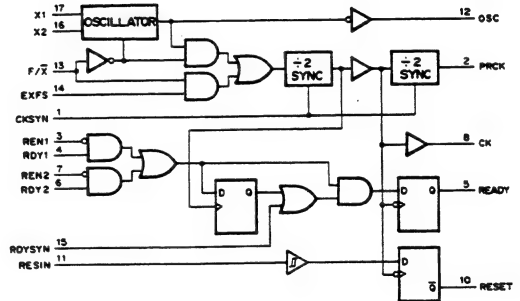



CXQ71054P (SONY)
 uPD71054C (NEC)
 C-MOS PROGRAMMABLE TIMER COUNTER
 — TOP VIEW —

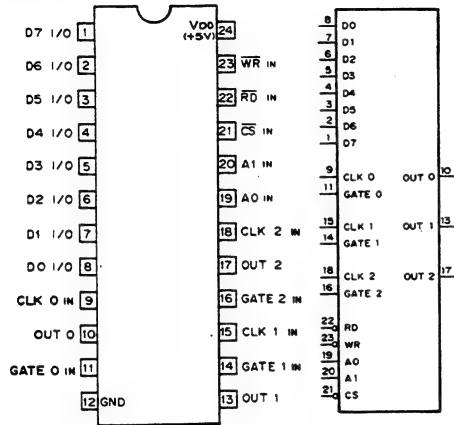

FUNCTION TABLE

| INPUTS | | | | | FUNCTION |
|--------|----|----|----|----|---------------------|
| CS | RD | WR | A1 | A0 | |
| 0 | 1 | 0 | 0 | 0 | Load Counter No. 0 |
| 0 | 1 | 0 | 0 | 1 | Load Counter No. 1 |
| 0 | 1 | 0 | 1 | 0 | Load Counter No. 2 |
| 0 | 1 | 0 | 1 | 1 | Control Word |
| 0 | 0 | 1 | 0 | 0 | Read Counter 0 |
| 0 | 0 | 1 | 0 | 1 | Read Counter 1 |
| 0 | 0 | 1 | 1 | 0 | Read Counter 2 |
| 0 | 0 | 1 | 1 | 1 | No-Operation (HI-Z) |
| 1 | X | X | X | X | Disable (HI-Z) |
| 0 | 1 | 1 | X | X | No-Operation (HI-Z) |

D7-D0 : 8-BIT DATA I/O
 CLK 0-2 : COUNTER CLOCK
 GATE 0-2 : COUNTER GATE
 OUT 0-2 : COUNTER OUTPUT
 RD : READ COUNTER
 WR : WRITE CMD OR DATA
 CS : CHIP SELECT
 A0,A1 : COUNTER SELECT

0; LOW LEVEL
 1; HIGH LEVEL
 X; DON'T CARE
 HI-Z; HIGH IMPEDANCE

CXQ71086P (SONY)
 uPD71086C (NEC)
 C-MOS 8-BIT BUS DRIVER/RECEIVER
 — TOP VIEW —

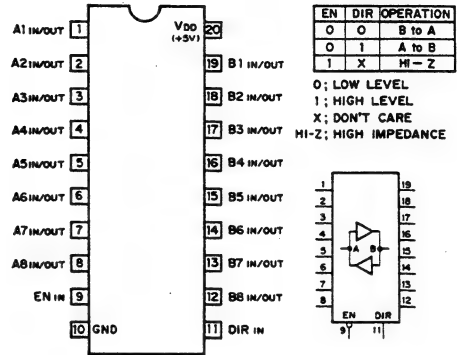

| EN | DIR | OPERATION |
|----|-----|-----------|
| 0 | 0 | B to A |
| 0 | 1 | A to B |
| 1 | X | HI-Z |

0; LOW LEVEL
 1; HIGH LEVEL
 X; DON'T CARE
 HI-Z; HIGH IMPEDANCE

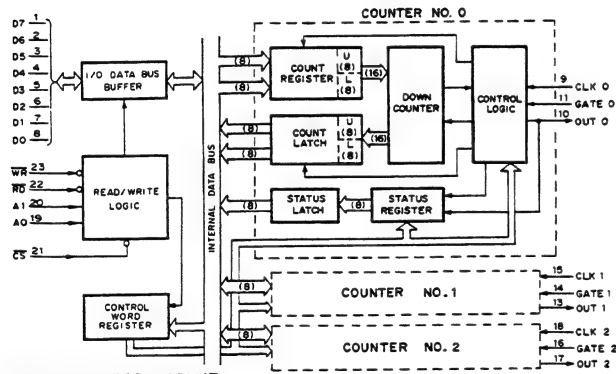
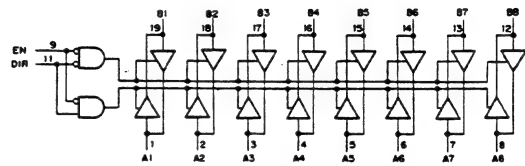

CONTROL WORD FORMAT

| D7 | D6 | D5 | D4 | D3 | D2 | D1 | D0 |
|-----|-----|-----|-----|----|----|----|-----|
| SC1 | SC0 | RL1 | RL0 | M2 | M1 | M0 | BCD |

| BCD | OPERATION |
|-----|----------------|
| 0 | 16-BIT BINARY |
| 1 | BCD (4-DECADE) |

| M2 | M1 | M0 | MODE |
|----|----|----|------|
| 0 | 0 | 0 | 0 |
| 0 | 0 | 1 | 1 |
| X | 1 | 0 | 2 |
| X | 1 | 1 | 3 |
| 1 | 0 | 0 | 4 |
| 1 | 0 | 1 | 5 |

| RL1 | RL0 | OPERATION |
|-----|-----|--------------------|
| 0 | 0 | COUNTER LATCHING |
| 0 | 1 | READ/LOAD LSB ONLY |
| 1 | 0 | READ/LOAD MSB ONLY |
| 1 | 1 | LSB FIRST THEN MSB |

| SC1 | SC0 | SELECTED COUNTER |
|-----|-----|--------------------|
| 0 | 0 | COUNTER No. 0 |
| 0 | 1 | COUNTER No. 1 |
| 1 | 0 | COUNTER No. 2 |
| 1 | 1 | MULTIPLE LATCH CMD |

CXQ70108-5 (SONY)
 CXQ70108-8 (SONY)
 uPD70108D-5 (NEC)
 uPD70108D-8 (NEC)
 C-MOS 8-BIT MICROPROCESSOR
 - TOP VIEW -

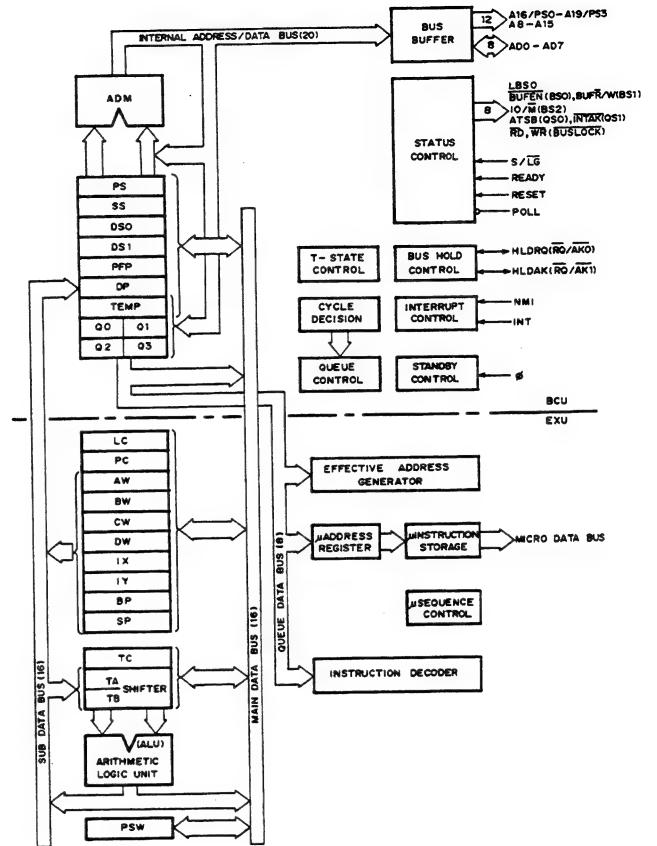
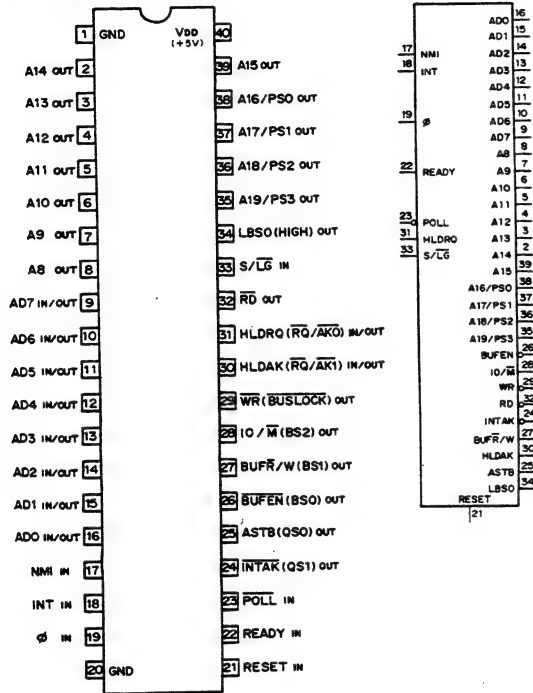

| PIN No. | FUNCTION | |
|---------|-----------------|----------------|
| | S/LG=HIGH LEVEL | S/LG=LOW LEVEL |
| 24 | INTAK | QS1 |
| 25 | ASTB | QSO |
| 26 | BUFEN | BS0 |
| 27 | BUF R/W | BS1 |
| 28 | IO/M | BS2 |
| 29 | WR | BUSLOCK |
| 30 | HLDAK | RQ/AK1 |
| 31 | HLDRO | RQ/AK0 |
| 34 | LBSO | HIGH LEVEL |

A8-A15; ADDRESS BUS OUTPUTS
 A00-AD7; ADDRESS/DATA BUS INPUTS/OUTPUTS
 NMI; NON-MASKABLE INTERRUPT INPUT
 INT; MASKABLE INTERRUPT INPUT
 φ; CLOCK INPUT
 INTAK; INTERRUPT ACKNOWLEDGE OUTPUT
 ASTB; ADDRESS STROBE OUTPUT
 BUFEN; BUFFER ENABLE OUTPUT
 BUF R/W; BUFFER READ/WRITE OUTPUT
 IO/M; IO/MEMORY OUTPUT
 WR; WRITE STROBE OUTPUT
 HLDRO; HOLD REQUEST INPUT
 HLDAK; HOLD ACKNOWLEDGE OUTPUT
 RD; READ STROBE OUTPUT
 S/LG; SMALL/LARGE INPUT
 LBSO; LATCHED BUS STATUS O OUTPUT
 A16/PS0-A19/PS3; ADDRESS BUS/PROCESSOR STATUS OUTPUTS
 QSO,1; QUEUE STATUS OUTPUTS
 BS0-BS2; BUS STATUS OUTPUTS
 BUSLOCK; BUS LOCK OUTPUT
 RQ/AK0,1; HOLD REQUEST/ACKNOWLEDGE INPUTS/OUTPUTS

CXQ71059P (SONY)
uPD71059C (NEC)
C-MOS INTERRUPT CONTROL UNIT
— TOP VIEW —

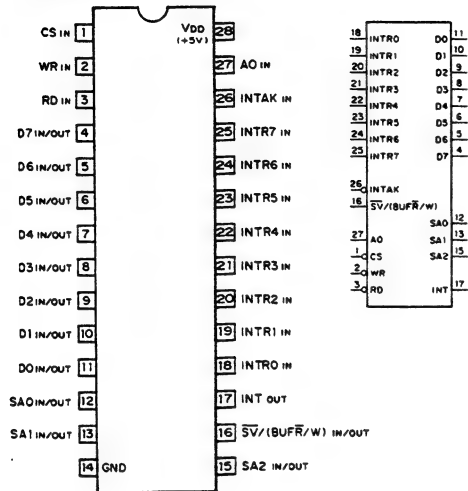

INTRO—INTR7 ; INTERRUPT REQUEST INPUTS
DO—D7 ; DATA BUS INPUTS/OUTPUTS
CS ; CHIP SELECT INPUT
RD ; READ STROBE INPUT
WR ; WRITE STROBE INPUT
AO ; ADDRESS INPUT
INT ; INTERRUPT OUTPUT
INTAK ; INTERRUPT ACKNOWLEDGE INPUT
SV/(BUF/R/W) ; SLAVE/BUFFER READ/WRITE INPUT/OUTPUT
SA0—SA2 ; SLAVE ADDRESS INPUTS/OUTPUTS

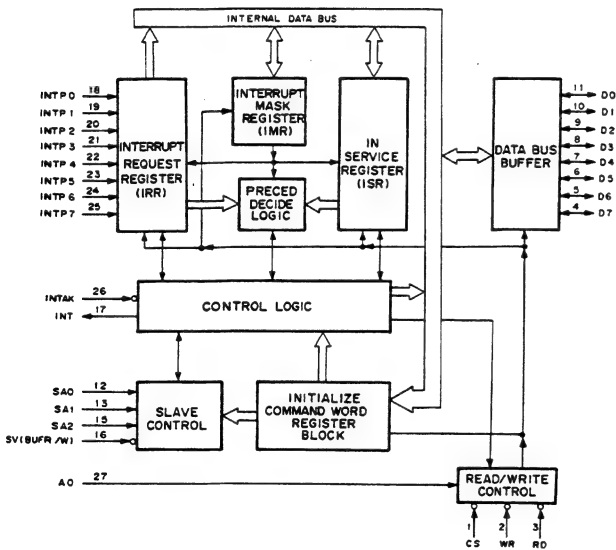

DS1210 (DALLAS SEMICONDUCTOR)
NONVOLATILE CONTROLLER
— TOP VIEW —

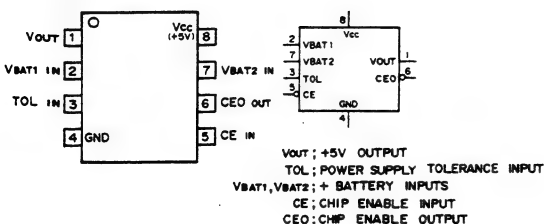

DS1235Y (DALLAS SEMICONDUCTOR)
MB84256-10 (FUJITSU) (ACCESS TIME = 100 nS)
MB84256-10LP (FUJITSU) (ACCESS TIME = 100 nS)
MB84256-12 (FUJITSU) (ACCESS TIME = 120 nS)
MB84256-12LP (FUJITSU) (ACCESS TIME = 120 nS)
MB84256-15 (FUJITSU) (ACCESS TIME = 150 nS)
MB84256-15LP (FUJITSU) (ACCESS TIME = 150 nS)
C-MOS 285k (3768x8)-BIT STATIC RAM
— TOP VIEW —

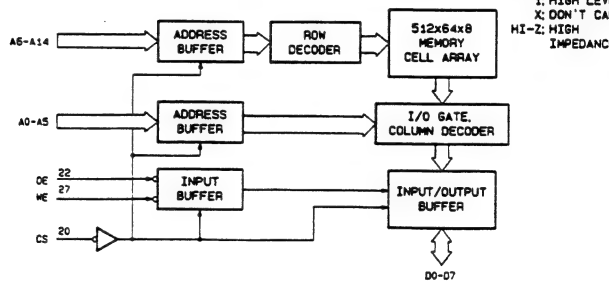
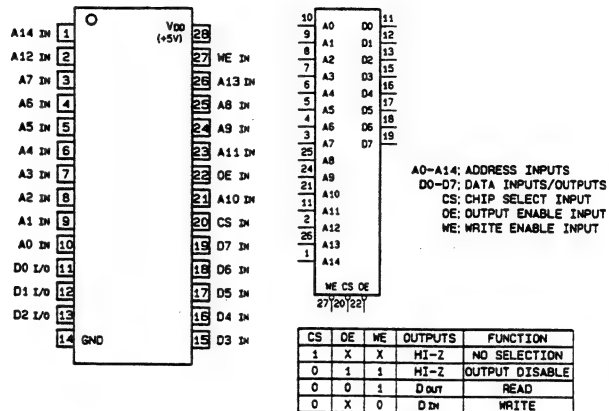

F10124 (FSC)
HD10124 (HITACHI)
MC10H124L (MOTOROLA)
MC10H124F (MOTOROLA) FLAT PACKAGE
MC10H124L (MOTOROLA)
MC10H124M (MOTOROLA) FLAT PACKAGE
ECL TTL-TO-ECL TRANSLATOR
— TOP VIEW —

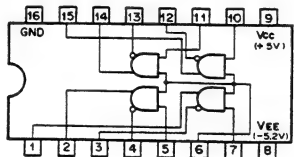

FT5761M (FUJITSU)
MP4504 (TOSHIBA)
DARLINGTON TRANSISTOR ARRAY
— PRINTED SIDE VIEW —

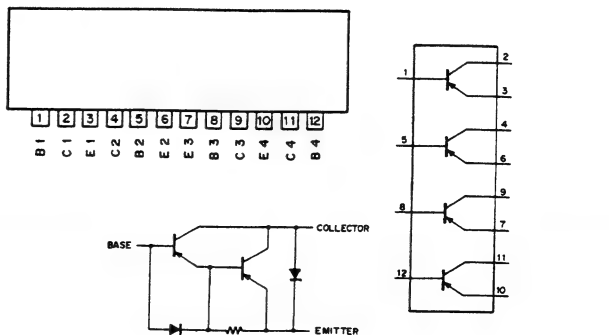

HD14538BFP (HITACHI) FLAT PACKAGE
 HD14538BP (HITACHI)
 M4538BP (MITUBISHI)
 MC14538BCP (MOTOROLA)
 MSM4538BRS (OKI)
 TC4538BF (TOSHIBA) FLAT PACKAGE
 TC4538BP (TOSHIBA)
 TC74HC4538F (TOSHIBA) FLAT PACKAGE
 uPD4538BC (NEC)
 C-MOS DUAL RETRIGGERABLE/NON-RETRIGGERABLE
 MONOSTABLE MULTIVIBRATOR

— TOP VIEW —

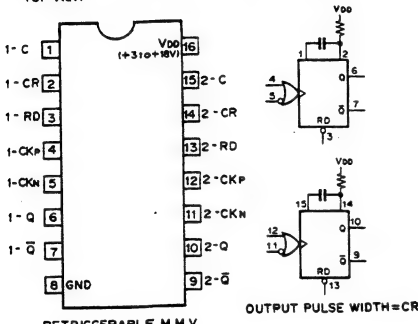

RETRIGGERABLE M.M.V

OUTPUT PULSE WIDTH=CR

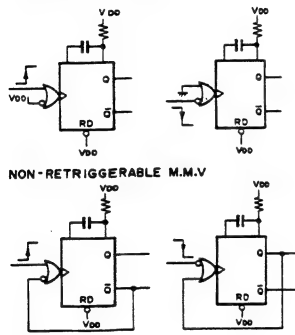

NON-RETRIGGERABLE M.M.V

HD14584BFP (HITACHI) FLAT PACKAGE
 HD14584BP (HITACHI)
 M4584BP (MITUBISHI)
 MC14584BCP (MOTOROLA)
 MSM4584RS (OKI)
 TC4584BP (TOSHIBA)
 uPD4584BC (NEC)
 uPD4584BG (TOSHIBA)
 C-MOS SCHMITT TRIGGER INVERTER

— TOP VIEW —

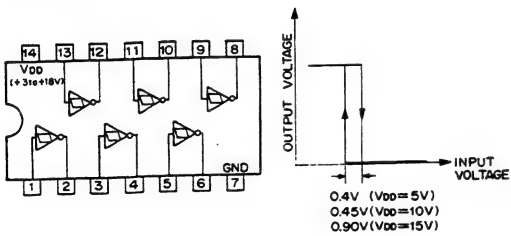

HD7406P (HITACHI)
 M53206P (MITSUBISHI)
 SN7406N (TI)
 SN7406NS (TI) FLAT PACKAGE
 SN74LS06N (TI)
 SN74LS06NS (TI) FLAT PACKAGE
 TTL INVERTER BUFFER/DRIVER WITH OPEN-COLLECTOR

— TOP VIEW —

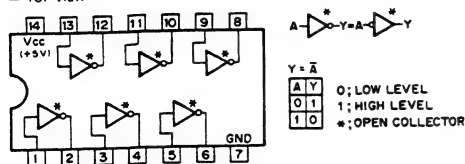

HD74HC00P (HITACHI)
 MC74HC00F (MOTOROLA) FLAT PACKAGE
 MC74HC00N (MOTOROLA)
 MN74HC00S (MATSUSHITA) FLAT PACKAGE
 MSM74HC00RS (OKI)
 SN74HC00N (TI)
 SN74HC00NS (TI) FLAT PACKAGE
 TC74HC00F (TOSHIBA) FLAT PACKAGE
 TC74HC00P (TOSHIBA)
 uPD74HC00C (NEC)
 uPD74HC00G (NEC) FLAT PACKAGE
 C-MOS 2-INPUT NAND GATE

— TOP VIEW —

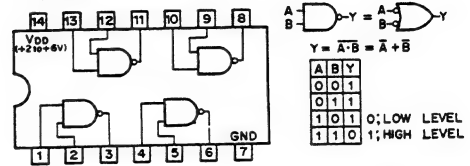

HD74HC02P (HITACHI)
 MC74HC02N (MOTOROLA)
 MSM74HC02RS (OKI)
 SN74HC02N (TI)
 SN74HC02NS (TI) FLAT PACKAGE
 TC74HC02F (TOSHIBA) FLAT PACKAGE
 TC74HC02P (TOSHIBA)
 uPD74HC02C (NEC)
 C-MOS 2-INPUT POSITIVE-NOR GATE

— TOP VIEW —

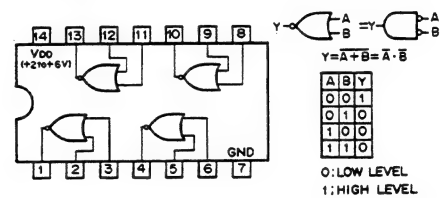

HD74HC04P (HITACHI)
 MC74HC04F (MOTOROLA) FLAT PACKAGE
 MC74HC04N (MOTOROLA)
 MC74HCT04N (MOTOROLA)
 MC74HCU04N (MOTOROLA)
 MN74HC04S (MATSUSHITA) FLAT PACKAGE
 MSM74HC04RS (OKI)
 SN74HC04N (TI)
 SN74HCU04N (TI)
 SN74HC04NS (TI) FLAT PACKAGE
 TC74HC04F (TOSHIBA) FLAT PACKAGE
 TC74HC04P (TOSHIBA)
 TC74HCT04P (TOSHIBA)
 TC74HCU04F (TOSHIBA) FLAT PACKAGE
 TC74HCU04P (TOSHIBA)
 uPD74HC04G (NEC) FLAT PACKAGE
 uPD74HCU04C (NEC)
 C-MOS INVERTER

— TOP VIEW —

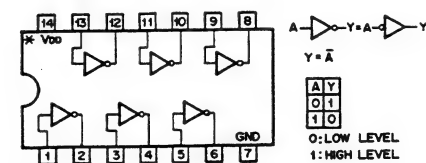

* VDD HC, HCU; +2 to +6V
 HCT; +5V

HD74HC08P (HITACHI)
 MC74HC08N (MOTOROLA)
 SN74HC08N (TI)
 SN74HC08NS (TI) FLAT PACKAGE
 TC74HC08F (TOSHIBA) FLAT PACKAGE
 TC74HC08P (TOSHIBA)
 uPD74HC08C (NEC)
 C-MOS 2-INPUT AND GATE
 — TOP VIEW —

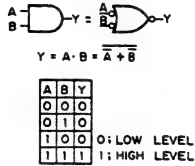
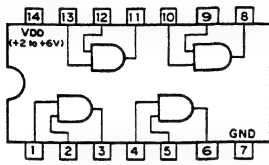

HD74HC107P (HITACHI)
 MC74HC107N (MOTOROLA)
 SN74HC107N (TI)
 TC74HC107P (TOSHIBA)
 C-MOS DUAL J-K FLIP-FLOPS
 — TOP VIEW —

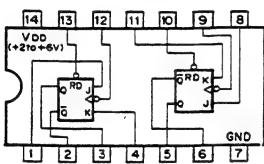

| INPUT | | | | OUTPUT |
|-------|----|---|---|-----------|
| RD | CK | J | K | Q |
| 0 | X | X | X | 0 |
| 1 | ↑ | 0 | 0 | NO CHANGE |
| 1 | ↑ | 1 | 0 | 1 |
| 1 | ↑ | 0 | 1 | 0 |
| 1 | ↑ | 1 | 1 | TOGGLE |

0: LOW LEVEL
 1: HIGH LEVEL
 X: DON'T CARE

HD74HC11P (HITACHI)
 MC74HC11F (MOTOROLA) FLAT PACKAGE
 MC74HC11N (MOTOROLA)
 SN74HC11N (TI)
 SN74HC11NS (TI) FLAT PACKAGE
 TC74HC11F (TOSHIBA) FLAT PACKAGE
 TC74HC11P (TOSHIBA)
 C-MOS 3-INPUT POSITIVE-AND GATE
 — TOP VIEW —

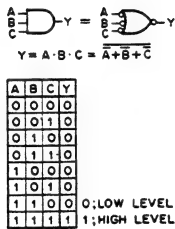
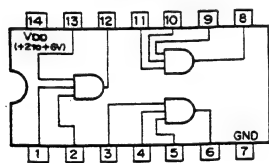

HD74HC123P (HITACHI)
 MC74HC123N (MOTOROLA)
 TC74HC123F (TOSHIBA) FLAT PACKAGE
 TC74HC123P (TOSHIBA)
 uPD74HC123AC (NEC)
 uPD74HC123C (NEC)
 C-MOS DUAL RETRIGGERABLE MONOSTABLE MULTIVIBRATOR
 — TOP VIEW —

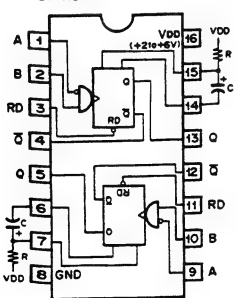

| INPUT | | | | OUTPUT | |
|-------|---|---|---|--------|--|
| RD | A | B | Q | Q-bar | |
| 0 | X | X | 0 | 1 | |
| 1 | 1 | X | 0 | 1 | |
| 1 | X | 0 | 0 | 1 | |
| 1 | 0 | 0 | 1 | 0 | |
| 1 | 1 | 0 | 1 | 0 | |
| 1 | 0 | 1 | 1 | 0 | |
| 1 | 1 | 1 | 1 | 0 | |

0: LOW LEVEL
 1: HIGH LEVEL
 X: DON'T CARE

OUTPUT PULSE WIDTH = 0.46CR

HD74HC125P (HITACHI)
 MC74HC125N (MOTOROLA)
 SN74HC125N (TI)
 uPD74HC125C (NEC)
 C-MOS BUS BUFFER GATES WITH 3-STATE OUTPUT
 — TOP VIEW —

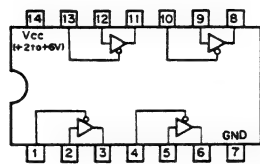

| G | A | Y |
|---|---|------|
| 0 | 0 | 0 |
| 0 | 1 | 1 |
| 1 | X | HI-Z |

0: LOW LEVEL
 1: HIGH LEVEL
 X: DON'T CARE
 HI-Z: HIGH IMPEDANCE

HD74HC126P (HITACHI)
 MC74HC126N (MOTOROLA)
 SN74HC126N (TI)
 C-MOS BUS BUFFER GATE WITH 3-STATE OUTPUT
 — TOP VIEW —

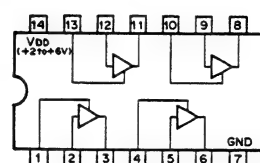

| G | A | Y |
|---|---|------|
| 0 | 0 | 0 |
| 0 | 1 | 1 |
| 1 | 0 | X |
| 1 | 1 | HI-Z |

0: LOW LEVEL
 1: HIGH LEVEL
 X: DON'T CARE
 HI-Z: HIGH IMPEDANCE

HD74HC138P (HITACHI)
 HD74HCT138P (HITACHI)
 MC74HC138N (MOTOROLA)
 MC74HCT138N (MOTOROLA)
 SN74HC138N (TI)
 SN74HC138NS (TI) FLAT PACKAGE
 TC74HC138F (TOSHIBA) FLAT PACKAGE
 TC74HC138P (TOSHIBA)
 TC74HCT138P (TOSHIBA)
 C-MOS 3-TO-8 LINE DECODER/DEMULTIPLEXER
 — TOP VIEW —

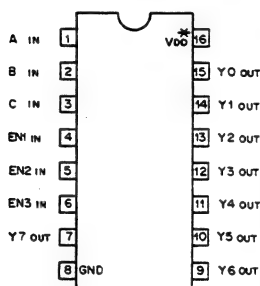

| INPUT | | | OUTPUT | | | | | | | | |
|-------|---|---|--------|----|----|----|----|----|----|----|----|
| EN | C | B | A | Y7 | Y6 | Y5 | Y4 | Y3 | Y2 | Y1 | Y0 |
| 0 | X | X | X | 1 | 1 | 1 | 1 | 1 | 1 | 1 | 1 |
| 1 | 0 | 0 | 0 | 1 | 1 | 1 | 1 | 1 | 1 | 1 | 0 |
| 1 | 0 | 0 | 1 | 1 | 1 | 1 | 1 | 1 | 1 | 0 | 1 |
| 1 | 0 | 1 | 0 | 1 | 1 | 1 | 1 | 1 | 1 | 0 | 1 |
| 1 | 0 | 1 | 1 | 1 | 1 | 1 | 1 | 1 | 0 | 1 | 1 |
| 1 | 1 | 0 | 0 | 1 | 1 | 1 | 1 | 0 | 1 | 1 | 1 |
| 1 | 1 | 0 | 1 | 1 | 1 | 1 | 1 | 0 | 1 | 1 | 1 |
| 1 | 1 | 1 | 0 | 1 | 0 | 1 | 1 | 1 | 1 | 1 | 1 |
| 1 | 1 | 1 | 1 | 0 | 1 | 1 | 1 | 1 | 1 | 1 | 1 |

EN = EN1-EN2-EN3
 0: LOW LEVEL
 1: HIGH LEVEL
 X: DON'T CARE

HD74HC139P (HITACHI)
 MC74HC139N (MOTOROLA)
 MSM74HC139S (OKI)
 SN74HC139N (TI)
 TC74HC139F (TOSHIBA) FLAT PACKAGE
 TC74HC139P (TOSHIBA)
 uPD74HC139C (NEC)
 C-MOS 1-OF-4 DECODER/DEMULTIPLEXER
 — TOP VIEW —

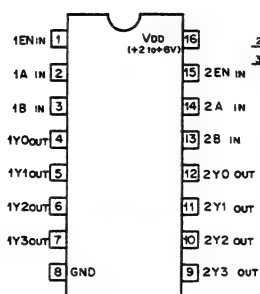

| INPUTS | | | OUTPUTS | | | |
|--------|---|---|---------|----|----|----|
| EN | B | A | Y3 | Y2 | Y1 | Y0 |
| 0 | 0 | 0 | 1 | 1 | 1 | 0 |
| 0 | 0 | 1 | 1 | 1 | 0 | 1 |
| 0 | 1 | 0 | 1 | 0 | 1 | 1 |
| 0 | 1 | 1 | 0 | 1 | 1 | 1 |
| 1 | X | X | 1 | 1 | 1 | 1 |

0: LOW LEVEL
 1: HIGH LEVEL
 X: DON'T CARE

HD74HC14P (HITACHI)
 MC74HC14N (MOTOROLA)
 MSM74HC14RS (OKI)
 SN74HC14N (TI)
 TC74HC14F (TOSHIBA) FLAT PACKAGE
 TC74HC14P (TOSHIBA)
 uPD74HC14C (NEC)
 uPD74HC14G (NEC) FLAT PACKAGE
 C-MOS SCHMITT TRIGGER INVERTER
 — TOP VIEW —

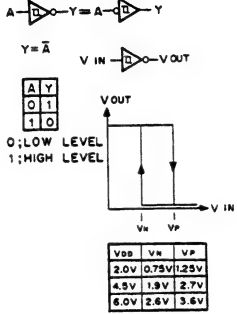
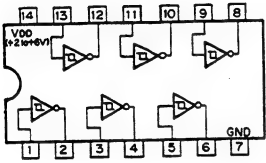

HD74HC153P (HITACHI)
 MC74HC153N (MOTOROLA)
 SN74HC153N (TI)
 SN74HC153NS (TI) FLAT PACKAGE
 TC74HC153F (TOSHIBA) FLAT PACKAGE
 TC74HC153P (TOSHIBA)
 C-MOS 4-LINE-TO-1-LINE DATA SELECTOR/MULTIPLEXER
 — TOP VIEW —

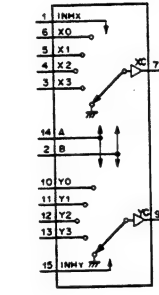
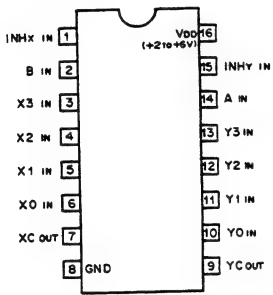

| CONTROL IN | | ON CHANNEL |
|------------|---|------------|
| INH | A | |
| 0 | 0 | 0 |
| 0 | 0 | 1 |
| 0 | 1 | 2 |
| 0 | 1 | 3 |
| 1 | X | GND |

0: LOW LEVEL
 1: HIGH LEVEL
 X: DON'T CARE

HD74HC157P (HITACHI)
 MC74HC157N (MOTOROLA)
 MSM74HC157RS (OKI)
 SN74HC157N (TI)
 TC74HC157F (TOSHIBA) FLAT PACKAGE
 TC74HC157P (TOSHIBA)
 uPD74HC157C (NEC)
 C-MOS 2-LINE-TO-1-LINE DATA SELECTOR/MULTIPLEXER
 — TOP VIEW —

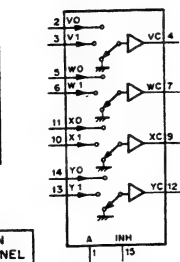
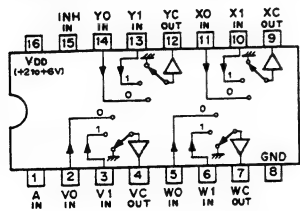

| CONT. IN | | ON CHANNEL |
|----------|---|------------|
| INH | A | |
| 0 | 0 | 0 |
| 0 | 1 | 1 |
| 1 | X | GND |

0: LOW LEVEL
 1: HIGH LEVEL
 X: DON'T CARE

HD74HC161P (HITACHI)
 MC74HC161N (MOTOROLA)
 SN74HC161N (TI)
 TC74HC161F (TOSHIBA) FLAT PACKAGE
 TC74HC161P (TOSHIBA)
 C-MOS SYNCHRONOUS PRESETTABLE 4-BIT BINARY COUNTER
 — TOP VIEW —

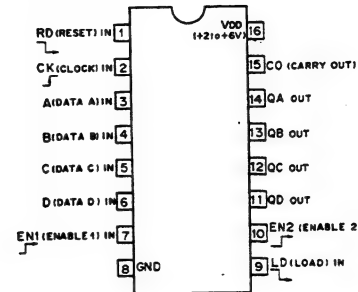

| MODE SELECTION | | | | MODE |
|----------------|----|-----|-----|----------------------|
| RD | LD | EN1 | EN2 | |
| 0 | X | X | X | RESET (ASYNCHRONOUS) |
| 1 | 0 | X | X | PRESET (SYNCHRONOUS) |
| 1 | 1 | 0 | X | NO COUNT |
| 1 | 1 | X | 0 | NO COUNT |
| 1 | 1 | 1 | 1 | COUNT |

0: LOW LEVEL
 1: HIGH LEVEL
 X: DON'T CARE

| COUNT | OUTPUT | | | |
|-------|--------|----|----|----|
| | QD | QC | QB | QA |
| 0 | 0 | 0 | 0 | 0 |
| 1 | 0 | 0 | 0 | 1 |
| 2 | 0 | 0 | 1 | 0 |
| 3 | 0 | 0 | 1 | 1 |
| 4 | 0 | 1 | 0 | 0 |
| 5 | 0 | 1 | 0 | 1 |
| 6 | 0 | 1 | 1 | 0 |
| 7 | 0 | 1 | 1 | 1 |
| 8 | 1 | 0 | 0 | 0 |
| 9 | 1 | 0 | 0 | 1 |
| 10 | 1 | 0 | 1 | 0 |
| 11 | 1 | 0 | 1 | 1 |
| 12 | 1 | 1 | 0 | 0 |
| 13 | 1 | 1 | 0 | 1 |
| 14 | 1 | 1 | 1 | 0 |
| 15 | 1 | 1 | 1 | 1 |

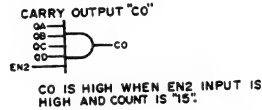

HD74HC164P (HITACHI)
 MC74HC164N (MOTOROLA)
 SN74HC164N (TI)
 TC74HC164P (TOSHIBA)
 uPD74HC164C (NEC)
 C-MOS 8-BIT SERIAL-IN/PARALLEL-OUT SHIFT REGISTER
 — TOP VIEW —

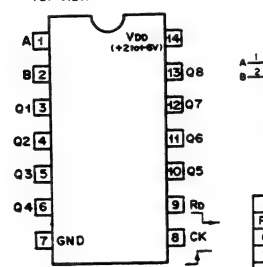

| INPUTS | | OUTPUTS | | | | | |
|--------|----|---------|---|-----|-----|-----|-----|
| Rd | CK | A | B | Q1 | Q2 | Q3 | Q4 |
| 0 | X | X | X | 0 | 0 | 0 | 0 |
| 1 | 0 | X | X | Q1o | Q2o | Q3o | Q4o |
| 1 | 1 | 1 | 1 | Q1n | Q2n | Q3n | Q4n |
| 1 | 1 | X | 0 | Q1n | Q2n | Q3n | Q4n |
| 1 | 1 | 0 | 0 | Q1n | Q2n | Q3n | Q4n |

0: LOW LEVEL
 1: HIGH LEVEL
 X: DON'T CARE

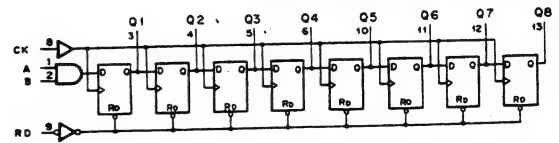

HD74HC165P (HITACHI)
 MC74HC165N (MOTOROLA)
 SN74HC165N (TI)
 TC74HC165P (TOSHIBA)
 C-MOS SERIAL-OR PARALLEL-INPUT SHIFT REGISTER
 — TOP VIEW —

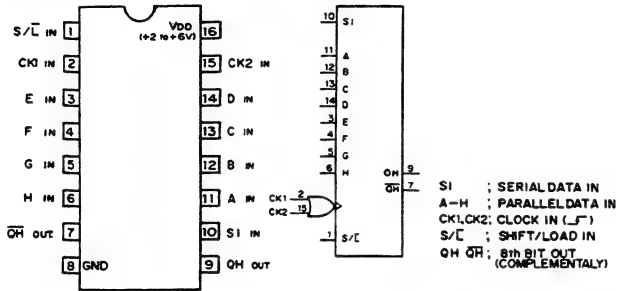

| INPUTS | | | CONTENTS/OUTPUT | | | | OPERATION |
|--------|---------|----|-----------------|------------|------------|-----|---------------|
| S/L | CK1+CK2 | SI | a.....h | QA | QB.... | QH | |
| 0 | X | X | a.....h | a | b.... | h | PARALLEL LOAD |
| 1 | ┘ | 0 | X | 0 | QAo... QGo | QHo | RIGHT SHIFT |
| 1 | ┘ | 1 | X | 0 | QAo... QGo | QHo | NO COUNT |
| 1 | 0 | X | X | QAo... QGo | QAo... QGo | QHo | |
| 1 | 1 | X | X | QAo... QGo | QAo... QGo | QHo | |

0; LOW LEVEL 1; HIGH LEVEL X; DON'T CARE
 a-h; LEVEL OF INPUTS A-H
 QAo-QHo; LEVEL OF QA-QH BEFORE THE INDICATED INPUT CONDITIONS WERE ESTABLISHED

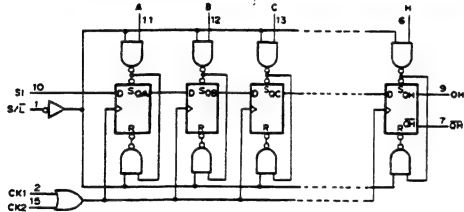

HD74HC174P (HITACHI)
 MC74HC174N (MOTOROLA)
 SN74HC174N (TI)
 TC74HC174F (TOSHIBA) FLAT PACKAGE
 TC74HC174P (TOSHIBA)
 C-MOS D-TYPE FLIP-FLOP WITH RESET
 — TOP VIEW —

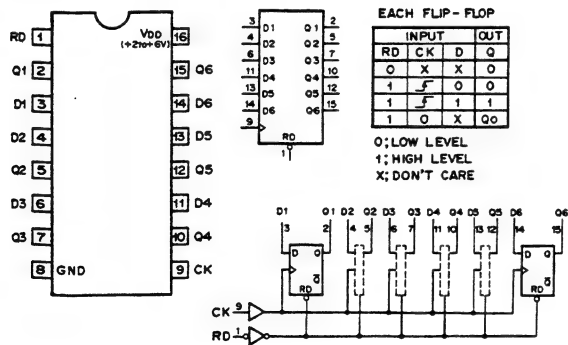

HD74HC175P (HITACHI)
 MC74HC175N (MOTOROLA)
 MSM74HC175RS (OKI)
 SN74HC175N (TI)
 SN74HC175NS (TI) FLAT PACKAGE
 TC74HC175F (TOSHIBA) FLAT PACKAGE
 TC74HC175P (TOSHIBA)
 uPD74HC175C (NEC)
 C-MOS D-TYPE FLIP-FLOP WITH RESET
 — TOP VIEW —

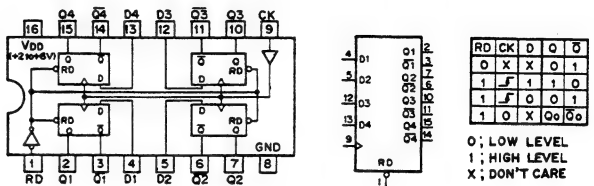

HD74HC244P (HITACHI)
 MC74HC244N (MOTOROLA)
 MC74HCT244N (MOTOROLA)
 MSM74HC244RS (OKI)
 SN74HC244N (TI)
 SN74HC244NS (TI) FLAT PACKAGE
 SN74HCT244N (TI)
 TC74HC244F (TOSHIBA) FLAT PACKAGE
 TC74HC244P (TOSHIBA)
 TC74HCT244P (TOSHIBA)
 uPD74HC244C (NEC)
 C-MOS BUS BUFFER WITH 3-STATE OUTPUT
 — TOP VIEW —

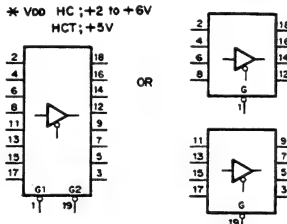
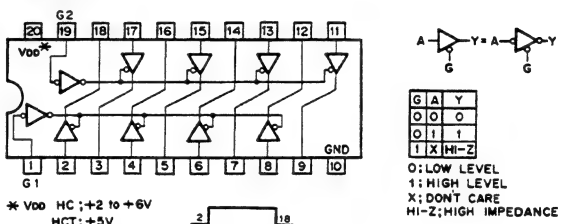

HD74HC245P (HITACHI)
 HD74HCT245P (HITACHI)
 MC74HC245N (MOTOROLA)
 MC74HCT245N (MOTOROLA)
 MSM74HC245RS (OKI)
 SN74HC245N (TI)
 SN74HC245NS (TI) FLAT PACKAGE
 SN74HCT245N (TI)
 TC74HC245F (TOSHIBA) FLAT PACKAGE
 TC74HC245P (TOSHIBA)
 uPD74HC245C (NEC)
 uPD74HC245G (NEC) FLAT PACKAGE
 C-MOS BILATERAL BUS TRANSCEIVERS WITH 3-STATE OUTPUT
 — TOP VIEW —

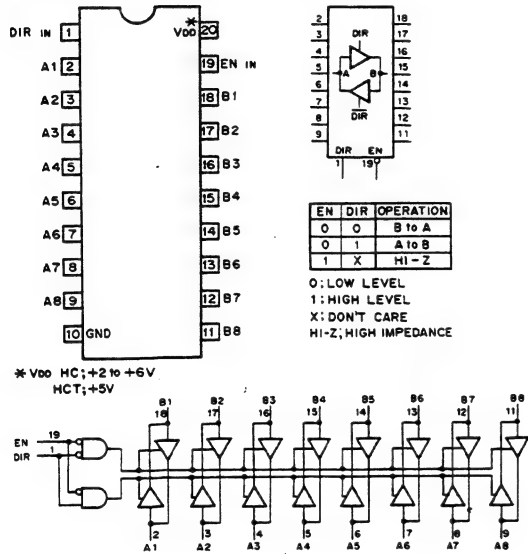

* VDD HC: +2 to +6V
 HCT: +5V

HD74HC32P (HITACHI)
 MC74HC32N (MOTOROLA)
 SN74HC32N (TI)
 SN74HC32NS (TI) FLAT PACKAGE
 TC74HC32F (TOSHIBA) FLAT PACKAGE
 TC74HC32P (TOSHIBA)
 C-MOS 2-INPUT OR GATE
 — TOP VIEW —

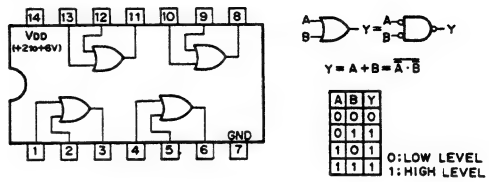

HD74HC367P (HITACHI)
 MC74HC367F (MOTOROLA)
 MC74HC367N (MOTOROLA)
 MN74HC367S (MATSUSHITA) FLAT PACKAGE
 SN74HC367N (TI)
 SN74HC367NS (TI) FLAT PACKAGE
 TC74HC367F (TOSHIBA) FLAT PACKAGE
 TC74HC367P (TOSHIBA)
 uPD74HC367C (NEC)
 uPD74HC367G (NEC) FLAT PACKAGE
 C-MOS BUS DRIVER WITH 3-STATE OUTPUTS
 — TOP VIEW —

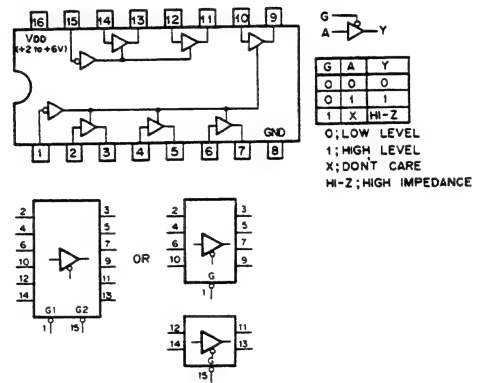

HD74HC273P (HITACHI)
 MC74HC273N (MOTOROLA)
 SN74HC273N (TI)
 SN74HC273NS (TI) FLAT PACKAGE
 TC74HC273F (TOSHIBA) FLAT PACKAGE
 TC74HC273P (TOSHIBA)
 C-MOS D-TYPE FLIP-FLOP WITH RESET
 — TOP VIEW —

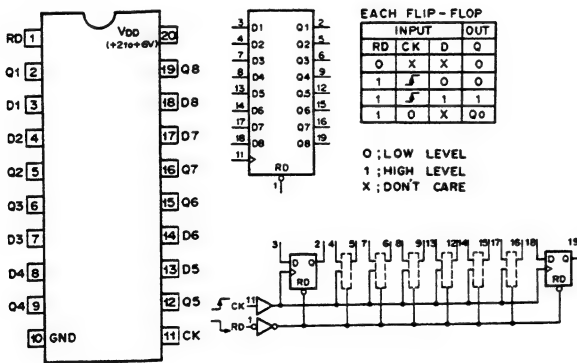

HD74HC373P (HITACHI)
 HD74HCT373P (HITACHI)
 MC74HC373N (MOTOROLA)
 MC74HCT373N (MOTOROLA)
 MSM74HC373RS (FUJITSU)
 SN74HC373N (TI)
 SN74HC373NS (TI) FLAT PACKAGE
 TC74HC373F (TOSHIBA) FLAT PACKAGE
 TC74HC373P (TOSHIBA)
 TC74HCT373P (TOSHIBA)
 uPD74HC373C (NEC)
 C-MOS 3-STATE OUTPUTS OCTAL LATCHES
 — TOP VIEW —

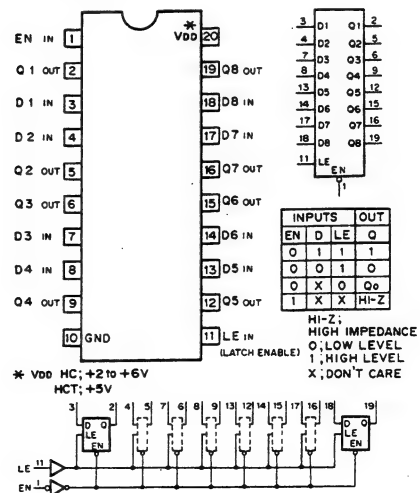

HD74HC374P (HITACHI)
 HD74HCT374P (HITACHI)
 MC74HC374F (MOTOROLA) FLAT PACKAGE
 MC74HC374N (MOTOROLA)
 MC74HCT374N (MOTOROLA)
 MN74HC374S (MATSUSHITA) FLAT PACKAGE
 MSM74HC374RS (OKI)
 SN74HC374N (TI)
 SN74HCT374N (TI)
 TC74HC374F (TOSHIBA) FLAT PACKAGE
 TC74HC374P (TOSHIBA)
 uPD74HC374C (NEC)
 uPD74HC374G (NEC) FLAT PACKAGE
 C-MOS 3-STATE OCTAL D-TYPE FLIP-FLOP
 — TOP VIEW —

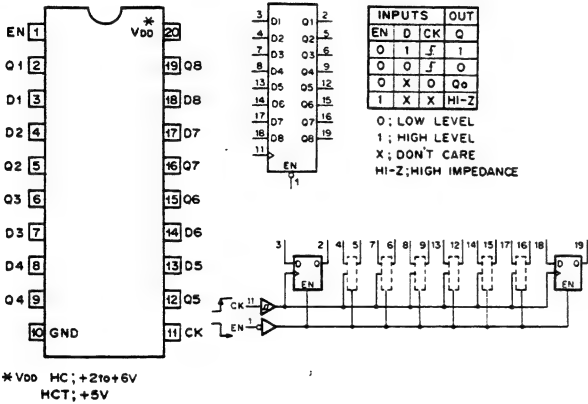

HD74HC4538P (HITACHI)
 MC74HC4538N (MOTOROLA)
 MSM74HC4538RS (OKI)
 TC74HC4538P (TOSHIBA)
 C-MOS DUAL RETRIGGERABLE/NON-RETRIGGERABLE MONOSTABLE MULTIVIBRATOR
 — TOP VIEW —

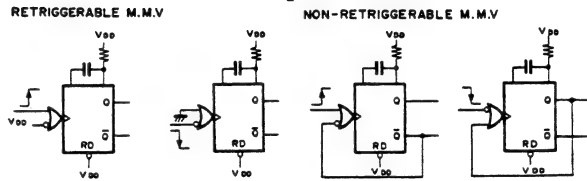
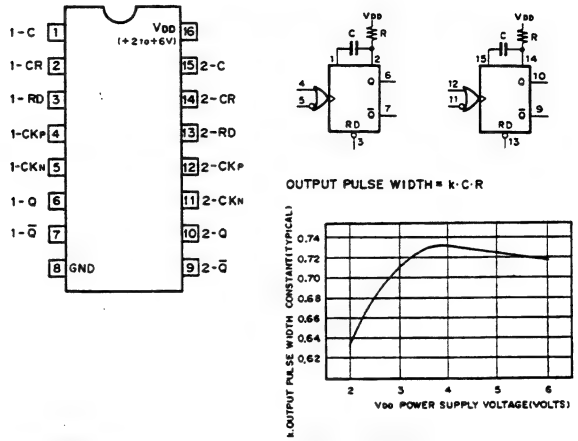

HD74HC4040P (HITACHI)
 MC74HC4040N (MOTOROLA)
 MSM74HC4040RS (OKI)
 SN74HC4040N (TI)
 SN74HC4040NS (TI) FLAT PACKAGE
 TC74HC4040P (TOSHIBA)
 C-MOS 12-STAGE RIPPLE CARRY BINARY COUNTER/DRIVER
 — TOP VIEW —

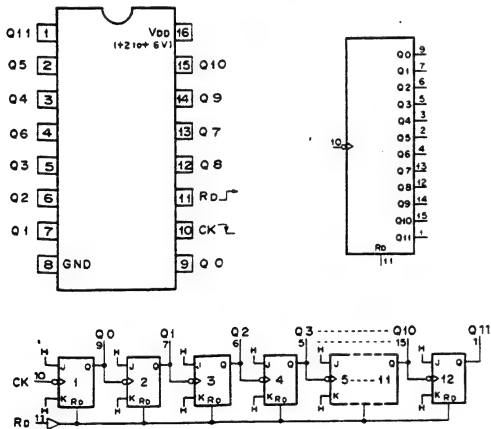

HD74HC74P (HITACHI)
 MC74HC74F (MOTOROLA) FLAT PACKAGE
 MC74HC74N (MOTOROLA)
 MN74HC74S (MATSUSHITA) FLAT PACKAGE
 MSM74HC74RS (OKI)
 SN74HC74N (TI)
 SN74HC74NS (TI) FLAT PACKAGE
 TC74HC74F (TOSHIBA) FLAT PACKAGE
 TC74HC74P (TOSHIBA)
 uPD74HC74C (NEC)
 uPD74HC74G (NEC) FLAT PACKAGE
 C-MOS D-TYPE FLIP FLOP WITH DIRECT SET/RESET
 — TOP VIEW —

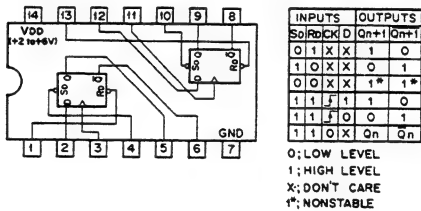

HD74HC86P (HITACHI)
 MC74HC86N (MOTOROLA)
 SN74HC86N (TI)
 SN74HC86NS (TI) FLAT PACKAGE
 TC74HC86F (TOSHIBA) FLAT PACKAGE
 TC74HC86P (TOSHIBA)
 uPD74HC86C (NEC)
 C-MOS EXCLUSIVE OR GATE
 — TOP VIEW —

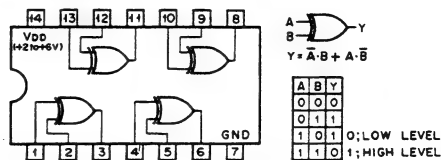

H11-0201-5 (HARRIS)
H11-201 (HARRIS)
C-MOS ANALOG SWITCH
— TOP VIEW —

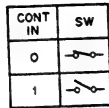
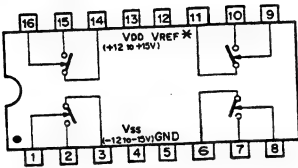

0 ; LOW LEVEL
1 ; HIGH LEVEL

* NOTE

| INTERFACIAL DEVICE | VREF CONNECTION |
|--------------------|-------------------------------------|
| TTL | Open |
| C-MOS | Open |
| | VDD ≤ 5.5V |
| | VDD > 5.5V To VDD of interfacial IC |

- HM6116ALSP-12 (HITACHI) (ACCESS TIME = 120 nS)
- HM6116ALSP-15 (HITACHI) (ACCESS TIME = 150 nS)
- HM6116ASP-12 (HITACHI) (ACCESS TIME = 120 nS)
- HM6116ASP-15 (HITACHI) (ACCESS TIME = 150 nS)
- HM6116LFP-2 (HITACHI) (ACCESS TIME = 120 nS) FLAT PACKAGE
- HM6116LFP-3 (HITACHI) (ACCESS TIME = 150 nS) FLAT PACKAGE
- HM6116LFP-4 (HITACHI) (ACCESS TIME = 200 nS) FLAT PACKAGE
- HM6116LP-2 (HITACHI) (ACCESS TIME = 120 nS)
- HM6116LP-3 (HITACHI) (ACCESS TIME = 150 nS)
- HM6116LP-4 (HITACHI) (ACCESS TIME = 200 nS)
- HM6116P-2 (HITACHI) (ACCESS TIME = 120 nS)
- HM6116P-3 (HITACHI) (ACCESS TIME = 150 nS)
- HM6116P-4 (HITACHI) (ACCESS TIME = 200 nS)
- M5B725P (MITSUBISHI) (ACCESS TIME = 200 nS)
- M5M5117P (MITSUBISHI) (ACCESS TIME = 200 nS)
- M5M5117P-12 (MITSUBISHI) (ACCESS TIME = 120 nS)
- M5M5117P-15 (MITSUBISHI) (ACCESS TIME = 150 nS)
- M8B416A-12P-SK (FUJITSU) (ACCESS TIME = 120 nS)
- M8B416A-15 (FUJITSU) (ACCESS TIME = 150 nS)
- M8B416A-15P-SK (FUJITSU) (ACCESS TIME = 150nS)
- M5M5128-12RS (OKI) (ACCESS TIME = 150 nS)
- M5M5128-15RS (OKI) (ACCESS TIME = 150 nS)
- M5M5128-20GS (OKI) (ACCESS TIME = 200 nS) FLAT PACKAGE
- M5M5128-20RS (OKI) (ACCESS TIME = 200 nS)
- TC5517AFL (TOSHIBA) (ACCESS TIME = 250 nS) FLAT PACKAGE
- TC5517APL (TOSHIBA) (ACCESS TIME = 250 nS)
- C-MOS 16384(2048x8)-BIT HIGH SPEED STATIC RAM

— TOP VIEW —

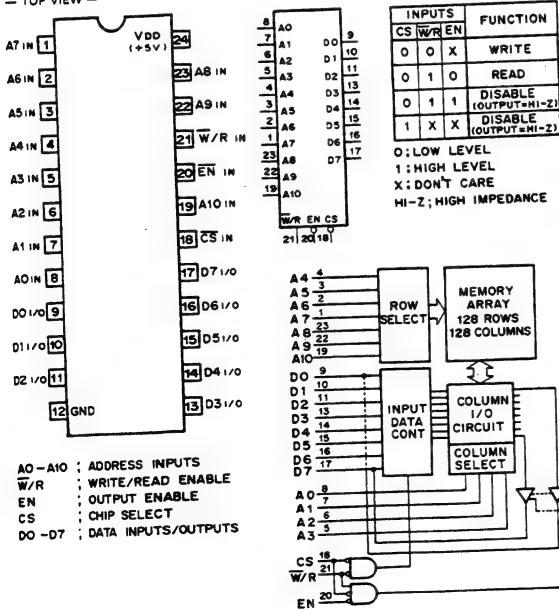

| INPUTS | | | FUNCTION |
|--------|-----|----|-----------------------|
| CS | W/R | EN | |
| 0 | 0 | X | WRITE |
| 0 | 1 | 0 | READ |
| 0 | 1 | 1 | DISABLE (OUTPUT=HI-Z) |
| 1 | X | X | DISABLE (OUTPUT=HI-Z) |

0 ; LOW LEVEL
1 ; HIGH LEVEL
X ; DON'T CARE
HI-Z ; HIGH IMPEDANCE

A0 - A10 : ADDRESS INPUTS
W/R : WRITE/READ ENABLE
EN : OUTPUT ENABLE
CS : CHIP SELECT
DO - D7 : DATA INPUTS/OUTPUTS

- HM6148HP-45 (HITACHI) C-MOS
- HM6148HP-55 (HITACHI) C-MOS
- M8B149-45 (FUJITSU) N-MOS
- M8B149-55 (FUJITSU) N-MOS
- M8B149-70 (FUJITSU) N-MOS
- M8B149L-55 (FUJITSU) N-MOS
- M8B149L-70 (FUJITSU) N-MOS
- MBM2149L-55 (FUJITSU) N-MOS
- MBM2149L-70 (FUJITSU) N-MOS
- 4096-BIT (1024x4) STATIC RAM WITH 3-STATE OUTPUT

— TOP VIEW —

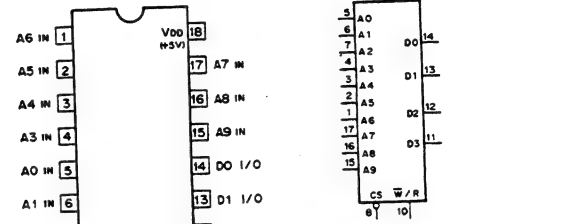

| CS | W/R | MODE | I/O |
|----|-----|---------|--------|
| 0 | 0 | WRITE | INPUT |
| 0 | 1 | READ | OUTPUT |
| 1 | X | INHIBIT | HIGH Z |

0 ; LOW LEVEL
1 ; HIGH LEVEL
X ; DON'T CARE
HIGH Z ; HIGH IMPEDANCE

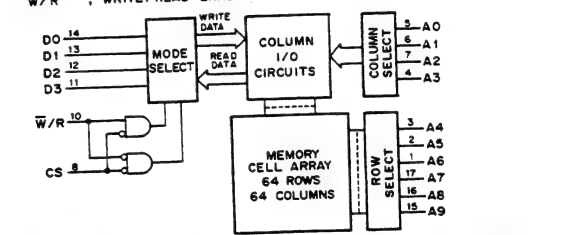

| TYPE | -45 | -55 | -70 | L-55 | L-70 | HP-45 | HP-55 |
|-------------------------------|-------|-------|-------|-------|-------|-------|-------|
| ADDRESS ACCESS TIME (MAX) | 45nS | 55nS | 70nS | 55nS | 70nS | 45nS | 55nS |
| CHIP SELECT ACCESS TIME (MAX) | 20nS | 25nS | 30nS | 25nS | 30nS | 45nS | 55nS |
| Icc (MAX) | 180mA | 180mA | 180mA | 125mA | 125mA | 80mA | 80mA |

- IR9494 (SHARP)
- IR3M02 (SHARP)
- M83759 (FUJITSU)
- TL494CN (TI)
- uPC494C (NEC)
- PWM POWER CONTROL

— TOP VIEW —

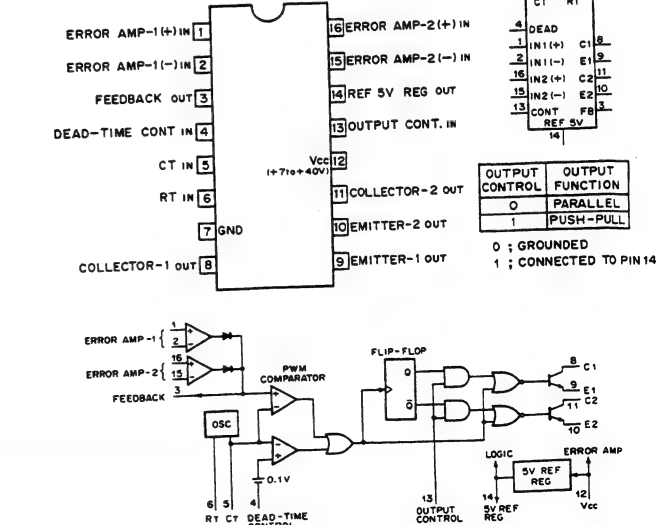

| OUTPUT CONTROL | OUTPUT FUNCTION |
|----------------|-----------------|
| 0 | PARALLEL |
| 1 | PUSH-PULL |

0 ; GROUND
1 ; CONNECTED TO PIN 14

LF398J (NS)
 LF398N (NS)
 uPC398C (NEC)
 uPC649C (NEC)
 SAMPLE AND HOLD CIRCUIT
 — TOP VIEW —

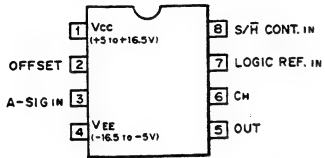

S/H CONT.: SAMPLE/HOLD CONTROL
 CH: EXTERNAL HOLD CAPACITOR

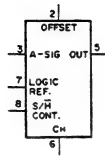

LM358JG (TI)
 LM358P (TI)
 uPC358C (NEC)
 uPC358G (NEC) FLAT PACKAGE
 uPC358G2 (NEC) FLAT PACKAGE
 DUAL OPERATIONAL AMPLIFIERS
 — TOP VIEW —

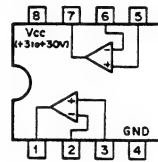

LM317T (NSC)
 3-TERMINAL ADJUSTABLE REGULATOR

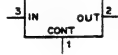
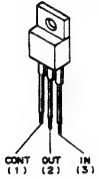

M5220P
 NJM2043D-D (JRC)
 NJM2043M-D (JRC) FLAT PACKAGE
 OPERATIONAL AMPLIFIER
 — TOP VIEW —

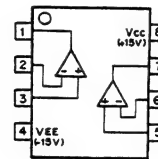

LM319N (NS)
 uPC319G2 (NEC) FLAT PACKAGE
 VOLTAGE COMPARATOR
 — TOP VIEW —

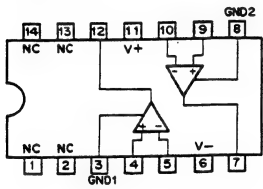

M5238P (MITSUBISHI)
 TLO72ACP (TI)
 TLO72BCP (TI)
 TLO72CP (TI)
 TLO72CPS (TI) FLAT PACKAGE
 OPERATIONAL AMPLIFIER
 (LOW-NOISE, JFET-INPUT)
 — TOP VIEW —

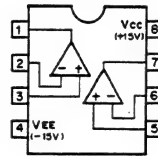

LM337T (NSC)
 3-TERMINAL ADJUSTABLE REGULATOR NEGATIVE

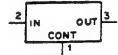
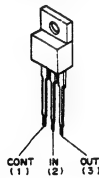

M5241L (MITSUBISHI)
 VOLTAGE CONTROLLED AMPLIFIER
 — PRINTED SIDE VIEW —

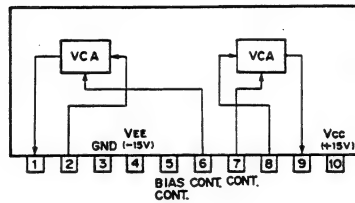

LM339 (NSC)
 MB4204 (FUJITSU)
 uPC339C (NEC)
 uPC339G2 (NEC) FLAT PACKAGE
 COMPARATOR
 — TOP VIEW —

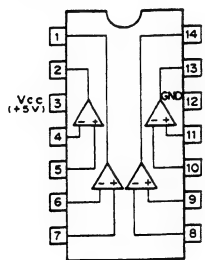

MB671131 (FUJITSU) FLAT PACKAGE
 C-MOS INTERFACE FOR MICROPROCESSOR
 - TOP VIEW -

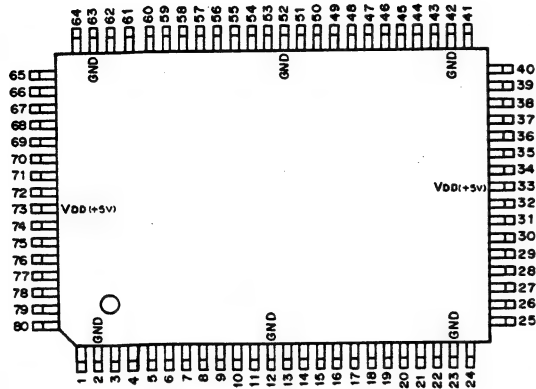

| PIN NO. | I/O | SYMBOL | PIN NO. | I/O | SYMBOL | PIN NO. | I/O | SYMBOL | PIN NO. | I/O | SYMBOL |
|---------|-----|--------|---------|-----|----------|---------|-----|--------|---------|-----|----------|
| 1 | I | CK2 | 21 | O | SIOQ | 41 | O | PIO1 | 61 | I | A13 |
| 2 | - | GND | 22 | O | VINT | 42 | - | GND | 62 | I | A12 |
| 3 | O | RDY2 | 23 | - | GND | 43 | O | PIO2 | 63 | - | GND |
| 4 | O | RDY1 | 24 | O | JCK | 44 | O | XINT | 64 | I | A11 |
| 5 | O | DK | 25 | O | SCK | 45 | O | CTC | 65 | I | A10 |
| 6 | I | RES | 26 | O | VOLO | 46 | O | SPAR | 66 | I | A9 |
| 7 | I | ASTB | 27 | O | JOGO | 47 | O | RAM | 67 | I | A8 |
| 8 | I | INTA | 28 | I | FRAM | 48 | O | SIO | 68 | - | NC |
| 9 | I | INT | 29 | O | XRES | 49 | O | ROM0 | 69 | I | AD7 |
| 10 | I | CK1 | 30 | O | OAO | 50 | O | ROM1 | 70 | I | AD6 |
| 11 | I | ELDI | 31 | O | OA1 | 51 | O | ROM2 | 71 | I | AD5 |
| 12 | - | GND | 32 | O | OA2 | 52 | - | GND | 72 | I | AD4 |
| 13 | O | ELDO | 33 | - | Vdd(+5V) | 53 | O | ROM3 | 73 | - | Vdd(+5V) |
| 14 | I | JOGI | 34 | O | OA3 | 54 | O | TPO | 74 | I | AD3 |
| 15 | I | VOLI | 35 | O | OA4 | 55 | O | TP1 | 75 | I | AD2 |
| 16 | I | SA2 | 36 | O | OAS | 56 | O | TP2 | 76 | I | AD1 |
| 17 | I | SA1 | 37 | O | OAG | 57 | I | A17 | 77 | I | AD0 |
| 18 | I | SA0 | 38 | O | OAT | 58 | I | A16 | 78 | I | RD |
| 19 | O | PRI | 39 | O | ELWR | 59 | I | A15 | 79 | I | WR |
| 20 | I | XSIO | 40 | O | ELRD | 60 | I | A14 | 80 | I | IO |

AD0-AD7; ADDRESS/DATA INPUTS
 A8-A17; ADDRESS INPUTS
 OAO-OA7; ADDRESS OUTPUTS
 ROM0-ROM3; PROM SELECT OUTPUTS
 SA0-SA2; SLAVE ADDRESS INPUTS
 TP0-TP2; TEST TERMINALS

IO; IO/MEMORY INPUT
 ASTB; ADDRESS STROBE INPUT
 RES; RESET PULSE INPUT
 JOGI; JOG DIAL PULSE INPUT
 VOLI; ROTARY ENCODER PULSE INPUT
 ELDI; DISPLAY DATA INPUT
 RD; READ STROBE INPUT
 WR; WRITE STROBE INPUT
 CK1; SYSTEM CLOCK INPUT
 INT; MASKABLE INTERRUPT INPUT
 INTA; INTERRUPT ACKNOWLEDGE INPUT
 XSIO; MPSC INTERRUPT REQUEST INPUT
 CK2; 29MHz CLOCK INPUT
 FRAM; FRAME PULSE INPUT

SPAR; SPARE PROGRAMMABLE TIMER COUNTER ENABLE OUTPUT
 CTC; PROGRAMMABLE TIMER COUNTER ENABLE OUTPUT
 XINT; INTERRUPT CONTROL UNIT ENABLE OUTPUT
 PIO1,PIO2; DATA BUS BUFFER ENABLE OUTPUTS
 SIO; MULTI-PROTOCOL SERIAL CONTROLLER ENABLE OUTPUT

RAM; RAM CHIP ENABLE OUTPUT
 XRES; RESET PULSE OUTPUT
 JOGO; JOG DIAL PULSE OUTPUT
 VOLO; ROTARY ENCODER PULSE OUTPUT
 ELDO; DISPLAY DATA OUTPUT
 ELRD; READ STROBE OUTPUT
 ELWR; WRITE STROBE OUTPUT
 RDY1,RDY2; BUS READY OUTPUTS

PRI; PRIORITY OUTPUT
 SIOQ; MPSC INTERRUPT REQUEST OUTPUT
 DCK; DATA TRANSMIT CLOCK OUTPUT (14.7456MHz)

SCK; RECEIVE/TRANSMIT CLOCK OUTPUT (1.2MHz)
 JCK; CLOCK OUTPUT (614kHz)
 VINT; INTERRUPT REQUEST OUTPUT

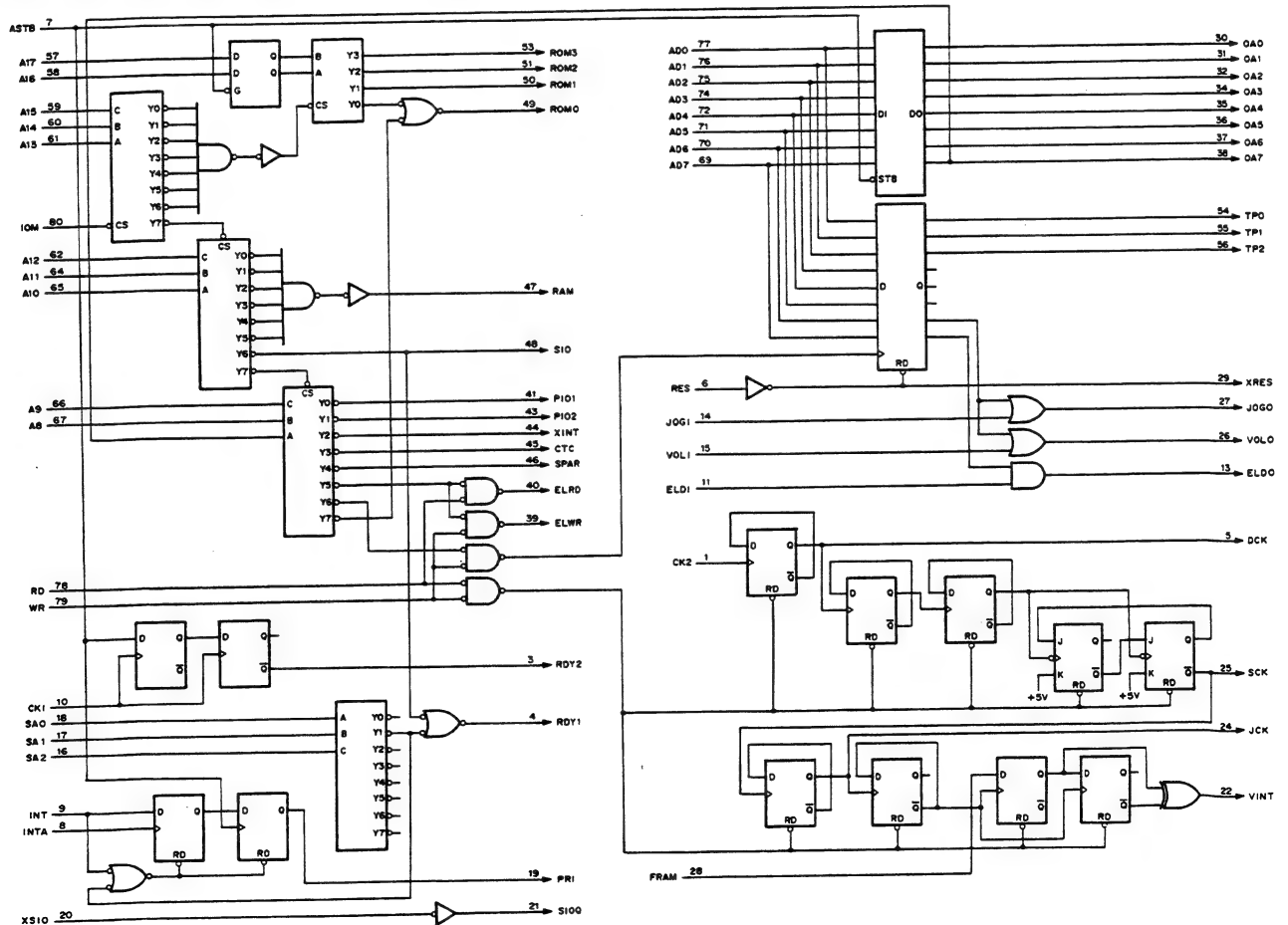
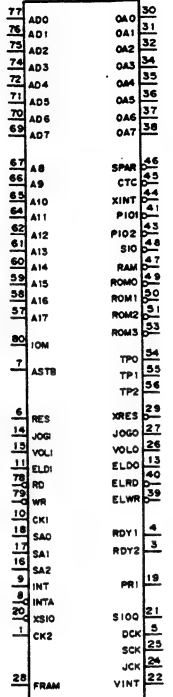

MBM2212-20 (FUJITSU) (ACCESS TIME = 200ns)
 MBM2212-20P (FUJITSU) (ACCESS TIME = 200ns)
 MBM2212-25 (FUJITSU) (ACCESS TIME = 250ns)
 X2212P (XICOR) (ACCESS TIME = 300ns)
 N-MOS 1024 (256x4)-BIT NONVOLATILE STATIC RAM
 — TOP VIEW —

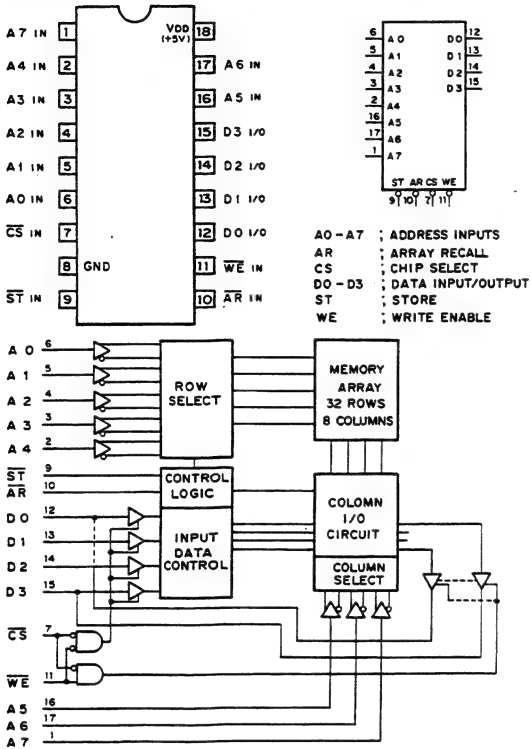

| INPUTS | | | | I/O | MODE |
|--------|----|----|----|--------------|---------------------|
| CS | WE | AR | ST | | |
| 1 | X | 1 | 1 | HI-Z | NOT SELECTED |
| 0 | 1 | 1 | 1 | OUTPUT DATA | RAM READ |
| 0 | 0 | 1 | 1 | INPUT DATA 1 | RAM WRITE "1" |
| 0 | 0 | 1 | 1 | INPUT DATA 0 | RAM WRITE "0" |
| X | 1 | 0 | 1 | HI-Z | ARRAY RECALL |
| 1 | X | 0 | 1 | HI-Z | ARRAY RECALL |
| X | 1 | 1 | 0 | HI-Z | NONVOLATILE STORING |
| 1 | X | 1 | 0 | HI-Z | NONVOLATILE STORING |

0 : LOW LEVEL
 1 : HIGH LEVEL
 X : DON'T CARE
 HI-Z : HIGH IMPEDANCE

MC34050P (MOTOROLA)
 RS-422 LINE DRIVER/RECEIVER
 — TOP VIEW —

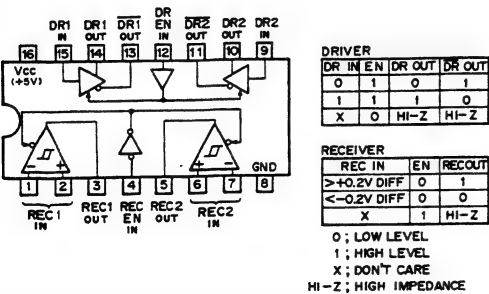

MC3486P (MOTOROLA)
 RS-422/423 LINE RECEIVER WITH 3-STATE OUTPUTS
 — TOP VIEW —

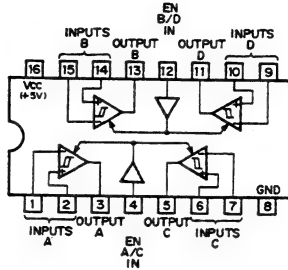

MC74HC221N (MOTOROLA)
 TC74HC221F (TOSHIBA) FLAT PACKAGE
 TC74HC221P (TOSHIBA)
 uPD74HC221AC (NEC)
 C-MOS MONOSTABLE MULTIVIBRATOR WITH SCHMITT TRIGGER INPUT
 — TOP VIEW —

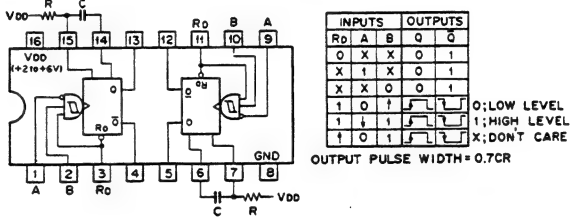

MC74HC4053F (MOTOROLA) FLAT PACKAGE
 MC74HC4053N (MOTOROLA)
 TC74HC4053P (TOSHIBA)
 C-MOS 2-CHANNEL MULTIPLEXER/DEMULTEPLEXER
 — TOP VIEW —

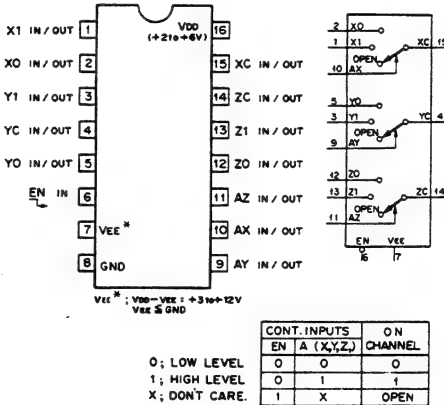

MC74HC541N (MOTOROLA)
 MC74HCT541F (TI) FLAT PACKAGE
 SN74HC541N (TI)
 SN74HCT541NS (TI) FLAT PACKAGE
 TC74HC541P (TOSHIBA)
 C-MOS BUFFERS AND LINE DRIVERS WITH 3-STATE OUTPUTS
 - TOP VIEW -

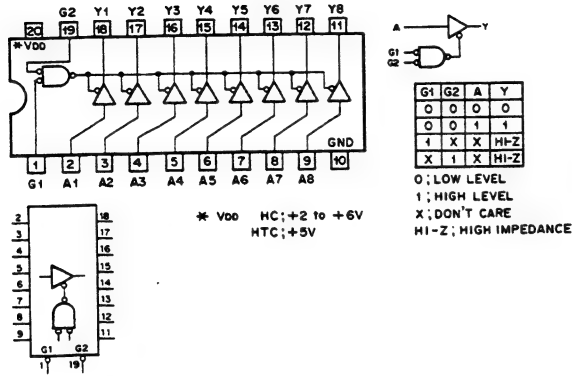

* V_{DD} HC: +2 to +6V
 HCT: +5V

MP6901 (TOSHIBA)
 POWER TRANSISTOR ARRAY
 - PRINTED SIDE VIEW -

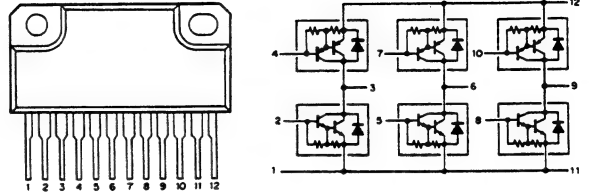

MSM4013RS (OKI)
 TC4013BF (TOSHIBA) FLAT PACKAGE
 TC4013BP (TOSHIBA)
 TC504013BF (TOSHIBA) FLAT PACKAGE
 TC504013BP (TOSHIBA)
 C-MOS D-TYPE FLIP FLOP WITH DIRECT SET/RESET
 - TOP VIEW -

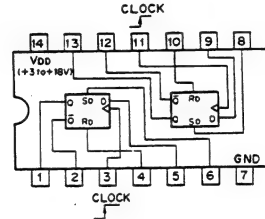

| S0/R0 | D | Q |
|-------|---|---|
| 0 | 0 | 0 |
| 0 | 1 | 0 |
| 1 | 0 | 1 |
| 1 | 1 | 1 |

CLOCK CK_n:
 CK_n: BEFORE CLOCK
 CK_{n+1}: AFTER CLOCK

O: LOW LEVEL
 1: HIGH LEVEL

MC74HC573N (MOTOROLA)
 SN74HC573N (TI)
 TC74HC573F (TOSHIBA) FLAT PACKAGE
 TC74HC573P (TOSHIBA)
 C-MOS 3-STATE OUTPUTS OCTAL LATCHES
 - TOP VIEW -

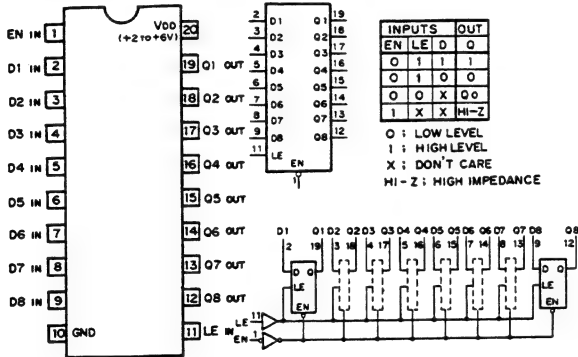

NJM082D (JRC)
 NJM082M (JRC) FLAT PACKAGE
 OPERATIONAL AMPLIFIER
 (J FET-INPUT)
 - TOP VIEW -

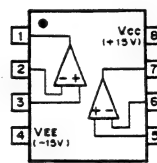

NJM2901N (JRC)
 SINGLE SUPPLY COMPARATOR
 - TOP VIEW -

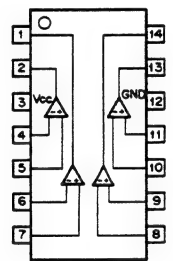

MC74HC574N (MOTOROLA)
 MSM74HC574RS (OKI)
 SN74HC574N (TI)
 SN74HCT574N (TI)
 TC74HC574F (TOSHIBA) FLAT PACKAGE
 TC74HC574P (TOSHIBA)
 TC74HCT574P (TOSHIBA)
 uPD74HC574C (NEC)
 C-MOS 3-STATE D-TYPE EDGE-TRIGGERED FLIP-FLOP
 - TOP VIEW -

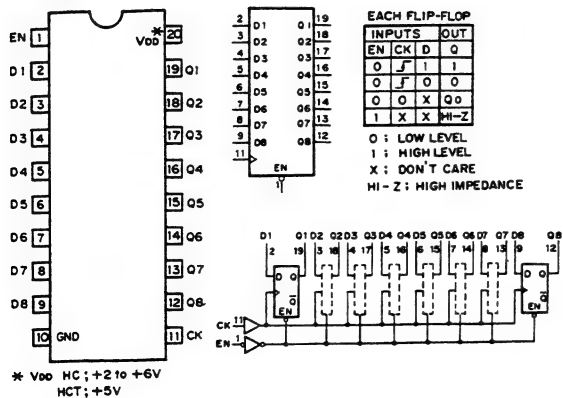

NJM2904D (JRC)
 NJM4556D (JRC)
 NJM4556M (JRC) FLAT PACKAGE
 NJM4556M-A (JRC) FLAT PACKAGE
 OPERATIONAL AMPLIFIER
 - TOP VIEW -

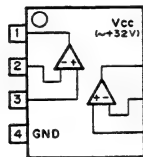

NJM4559D (JRC)
 OPERATIONAL AMPLIFIER
 - TOP VIEW -

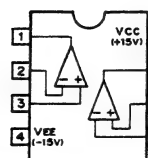

NJM4560D (JRC)
 NJM4560DD (JRC)
 NJM4560DN (JRC)
 NJM4560DX (JRC)
 NJM4560M (JRC) FLAT PACKAGE
 OPERATIONAL AMPLIFIER
 - TOP VIEW -

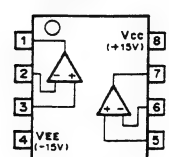

NJM78M ? 7A (JRC)
POSITIVE VOLTAGE REGULATOR (500mA)
— FRONT VIEW —

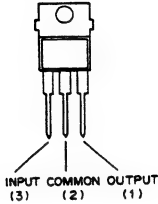

- 5V NJM78M05A
- 6V NJM78M06A
- 8V NJM78M08A
- 9V NJM78M09A
- 12V NJM78M12A
- 15V NJM78M15A
- 18V NJM78M18A
- 20V NJM78M20A
- 24V NJM78M24A

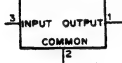

NJM79L ? 7A (JRC)
NEGATIVE VOLTAGE REGULATOR (100mA)
— FRONT VIEW —

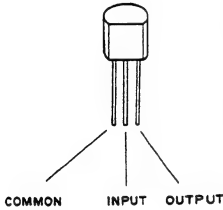

| OUTPUT VOLTAGE | NJM79LPPA |
|----------------|-----------|
| -3V | NJM79L03A |
| -4V | |
| -5V | NJM79L05A |
| -6V | NJM79L06A |
| -7V | |
| -8V | NJM79L08A |
| -9V | NJM79L09A |
| -10V | |
| -12V | NJM79L12A |
| -15V | NJM79L15A |
| -18V | NJM79L18A |
| -20V | |
| -24V | NJM79L24A |

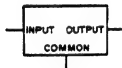

NJM79M ? 7A (JRC)
NEGATIVE VOLTAGE REGULATOR (500mA)
— FRONT VIEW —

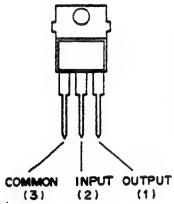

- 5V NJM79M05A
- 6V NJM79M06A
- 8V NJM79M08A
- 9V NJM79M09A
- 12V NJM79M12A
- 15V NJM79M15A
- 18V NJM79M18A
- 24V NJM79M24A

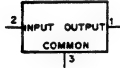

PC627 (SHARP)
TTL-PHOTOELECTRIC CELL
— TOP VIEW —

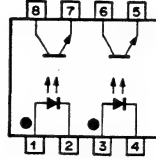

SN75160AN (TI)
SN75160AN-R (TI)
SN75160N (TI)
OCTAL GENERAL-PURPOSE INTERFACE BUS TRANSCEIVERS
— TOP VIEW —

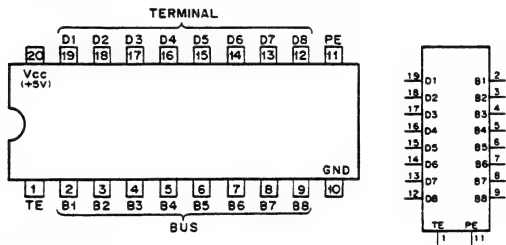

TE; TALK ENABLE
PE; PULL-UP ENABLE

DRIVERS

| INPUTS | | OUTPUT | |
|--------|-------|--------|---|
| D | TE PE | B | |
| 1 | 1 1 | 1 | 1 |
| 0 | 1 X | 0 | 0 |
| 1 | X 0 | Z | Z |
| X | 0 X | Z | Z |

RECEIVERS

| INPUTS | | OUTPUT | |
|--------|-------|--------|---|
| B | TE PE | D | |
| 0 | 0 X | 0 | 0 |
| 1 | 0 X | 1 | 1 |
| X | 1 X | Z | Z |

O; LOW LEVEL
1; HIGH LEVEL
X; DON'T CARE
Z; HIGH IMPEDANCE

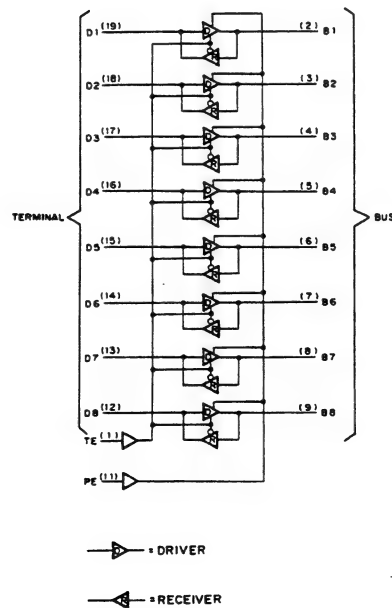

SN75161AN (TI)
INTERFACE BUS TRANSCEIVERS
— TOP VIEW —

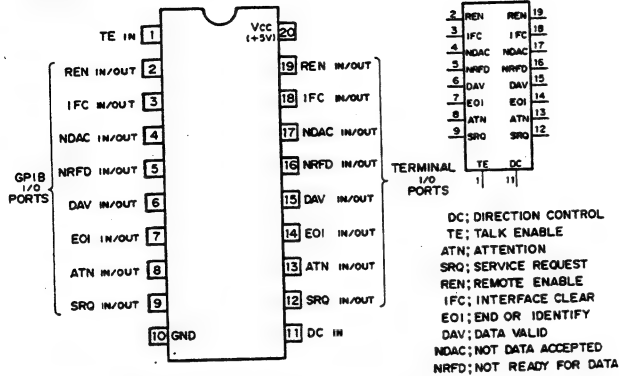

RECEIVE/TRANSMIT FUNCTION TABLE

| CONTROLS | BUS-MANAGEMENT CHANNELS | | | | DATA-TRANSFER CHANNELS | | | | | | |
|----------|-------------------------|----|-----|-----|------------------------|-----|-----|-----|-----|------|------|
| | DC | TE | ATN | EOI | ATN | SRQ | REN | IFC | DAV | NDAC | NRFD |
| 1 | 1 | 1 | | | R | T | R | R | T | R | R |
| 1 | 1 | 0 | | | | | | | | | |
| 0 | 0 | 1 | | | T | R | T | T | R | T | T |
| 0 | 0 | 0 | | | | | | | | | |
| 1 | 0 | X | | | R | T | R | R | R | T | T |
| 0 | 1 | X | | | T | R | T | T | T | R | R |

0: LOW LEVEL
1: HIGH LEVEL
X: DONT CARE
R: RECEIVE (TERMINAL ← GPIB)
T: TRANSMIT (TERMINAL → GPIB)

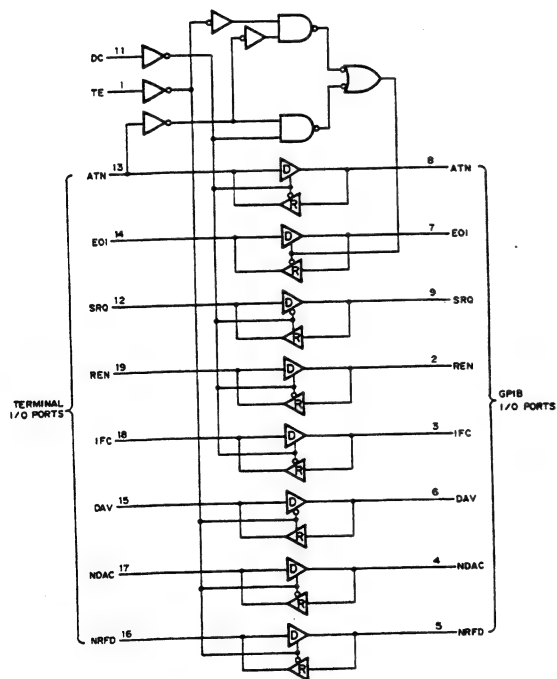

SN76489AN (TI)
IIL PROGRAMMABLE SOUND GENERATION CONTROLLER
— TOP VIEW —

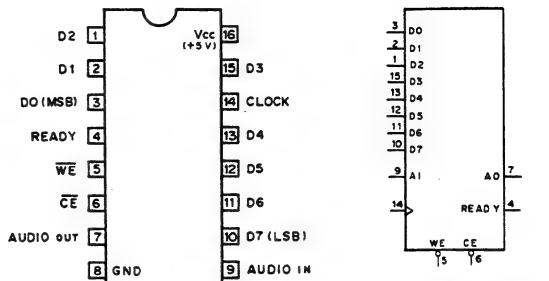

| CE | WE | READY |
|----|----|------------------------------------|
| 1 | X | 1 |
| 0 | 1 | 0 |
| 0 | 0 | 0 (DURING 32 CLOCKES INPUT) → 1 |

0: LOW LEVEL
1: HIGH LEVEL
X: DONT CARE

CE: CHIP ENABLE
WE: WRITE ENABLE
A1: AUDIO INPUT
AO: AUDIO OUTPUT

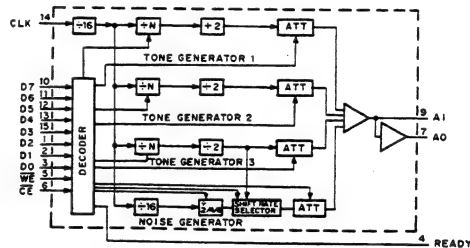

TA7257P (TOSHIBA)
FULL-BRIDGE DRIVER FOR DC MOTOR (H-SWITCH)
— PRINTED SIDE VIEW —

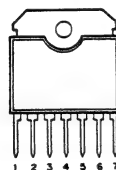

| IN1 | IN2 | OUT1 | OUT2 | MODE |
|-----|-----|------|------|-----------------|
| 1 | 1 | 0 | 0 | BRAKE |
| 0 | 1 | 0 | 1 | FORWARD/REVERSE |
| 1 | 0 | 1 | 0 | REVERSE/FORWARD |
| 0 | 0 | HI-Z | HI-Z | STOP |

0: LOW LEVEL HI-Z: HIGH IMPEDANCE
1: HIGH LEVEL

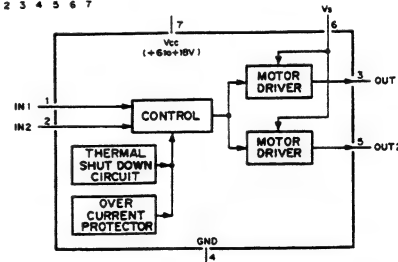

TA7267P (TOSHIBA)
DC MOTOR DRIVER
— PRINTED SIDE VIEW —

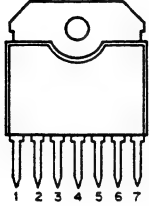

| INPUTS | OUTPUTS | MODE | | |
|--------|---------|------|---|--------------------------|
| 1 | 2 | 1 | 2 | |
| 1 | 1 | 0 | 0 | BRAKE |
| 0 | 1 | 0 | 1 | ROTATION / REV. ROTATION |
| 1 | 0 | 1 | 0 | REV. ROTATION / ROTATION |
| 0 | 0 | H-Z | | STOP |

0 : LOW LEVEL
1 : HIGH LEVEL
H-Z : HIGH IMPEDANCE

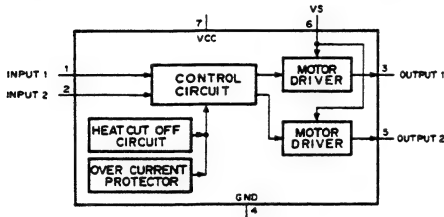

TA7368P (TOSHIBA)
LOW FREQUENCY POWER AMPLIFIER
— PRINTED SIDE —

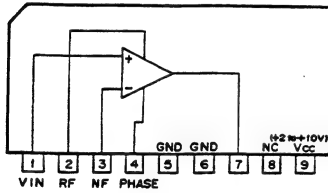

RF : RIPPLE FILTER
NF : NEGATIVE FEEDBACK

TA78L??AP (TOSHIBA)
POSITIVE VOLTAGE REGULATOR (150mA)

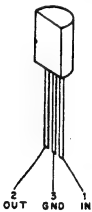

| OUTPUT VOLTAGE | PPP |
|----------------|-----|
| +5V | 005 |
| +6V | 006 |
| +7V | 007 |
| +7.5V | 075 |
| +8V | 008 |
| +9V | 009 |
| +10V | 010 |
| +12V | 012 |
| +13.2V | 132 |
| +15V | 015 |
| +18V | 018 |
| +20V | 020 |
| +24V | 024 |

TC40107BP (TOSHIBA)
C-MOS NAND BUFFER/DRIVER WITH OPEN-DRAIN
— TOP VIEW —

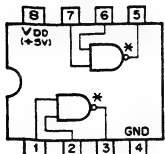

| A | B | Y | |
|---|---|------|-----------------------|
| 0 | 0 | HI-Z | 0 : LOW LEVEL |
| 0 | 1 | HI-Z | 1 : HIGH LEVEL |
| 1 | 0 | HI-Z | HI-Z : HIGH IMPEDANCE |
| 1 | 1 | 0 | * : OPEN-DRAIN |

TC5020BP (TOSHIBA)
C-MOS LOW-TO-HIGH VOLTAGE TRANSLATION INVERTER
— TOP VIEW —

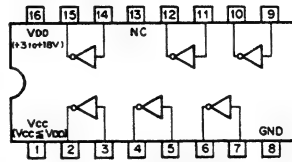

$Y = \bar{A}$

| A | Y |
|---|---|
| 0 | 1 |
| 1 | 0 |

0 : LOW LEVEL
1 : HIGH LEVEL

TL082ACP (TI)
TL082BCP (TI)
TL082CP (TI)
TL082CPS (TI) FLAT PACKAGE
uPC4082C (NEC)
OPERATIONAL AMPLIFIER
(J FET-INPUT)
— TOP VIEW —

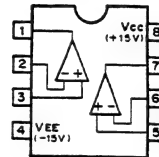

TL084ACN (TI)
TL084BCN (TI)
TL084CN (TI)
TL084CNS (TI) FLAT PACKAGE
uPC4084C (NEC)
OPERATIONAL AMPLIFIER
(J FET-INPUT)
— TOP VIEW —

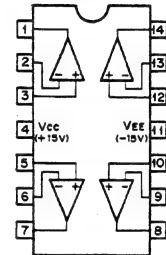

SN72607P (TI)
TL607CP (TI)
TL607CPS (TI) FLAT PACKAGE
P-MOS ANALOG SWITCH
— TOP VIEW —

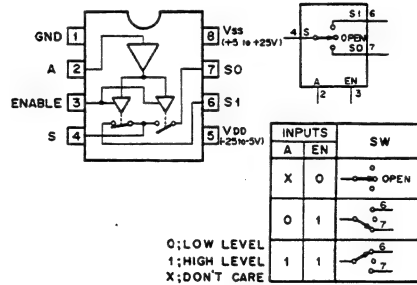

TL7705ACP (TI)
TL7705CP (TI)
POWER VOLTAGE SUPERVISOR
— TOP VIEW —

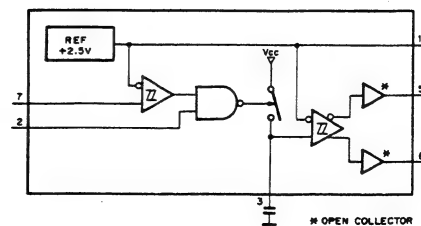
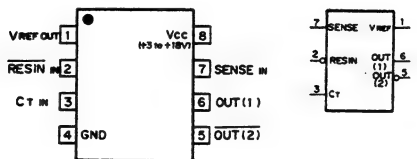

uPC1513HA (NEC)
AUDIO HEAD SELECT SWITCH
— PRINTED SIDE VIEW —

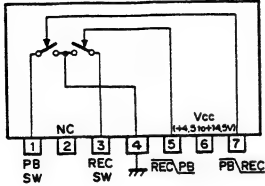

uPC272C (NEC)
uPC319C (NEC)
DUAL VOLTAGE COMPARATOR
— TOP VIEW —

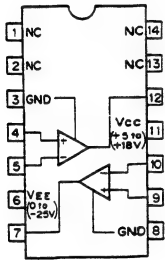

uPC4556C (NEC)
OPERATIONAL AMPLIFIER
(WIDE BAND, DECOMPENSATED)
— TOP VIEW —

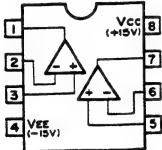

uPC458C (NEC)
uPC4741G (NEC) FLAT PACKAGE
OPERATIONAL AMPLIFIER
— TOP VIEW —

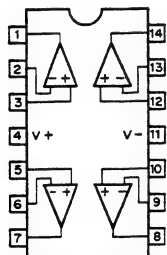

$4V \leq (V+) - (V-) \leq 40V$

uPC648C (NEC)
uPC648D (NEC)
12-BIT D/A CONVERTER WITH OPEN COLLECTOR OUTPUT
— TOP VIEW —

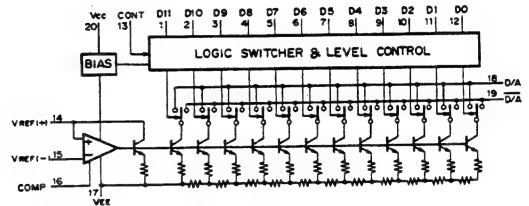
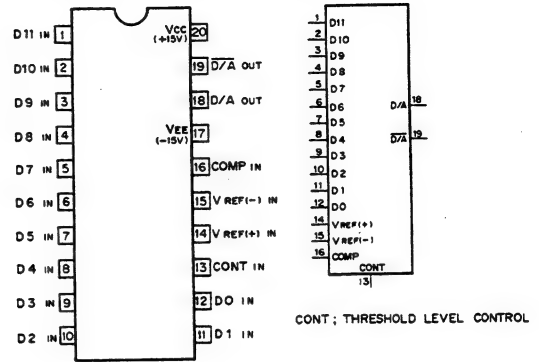

uPD3341C (NEC)
N-MOS 256-BIT (64x4) FIRST-IN FIRST-OUT SERIAL MEMORY
— TOP VIEW —

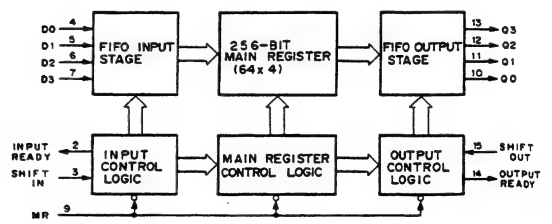
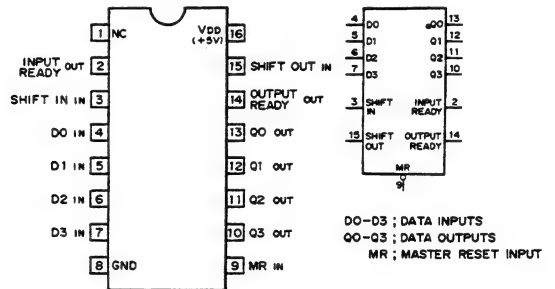

uPD43256C-10 (NEC) (ACCESS TIME = 100 nS)
 uPD43256C-10L (NEC) (ACCESS TIME = 100 nS)
 uPD43256C-12 (NEC) (ACCESS TIME = 120 nS)
 uPD43256C-12L (NEC) (ACCESS TIME = 120 nS)
 uPD43256C-15 (NEC) (ACCESS TIME = 150 nS)
 uPD43256C-15L (NEC) (ACCESS TIME = 150 nS)
 C-MOS 262144 (32768x8) BIT STATIC RAM
 — TOP VIEW —

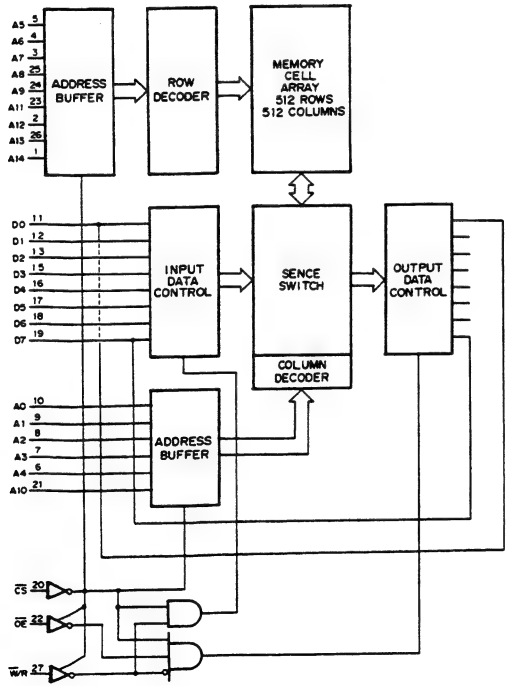
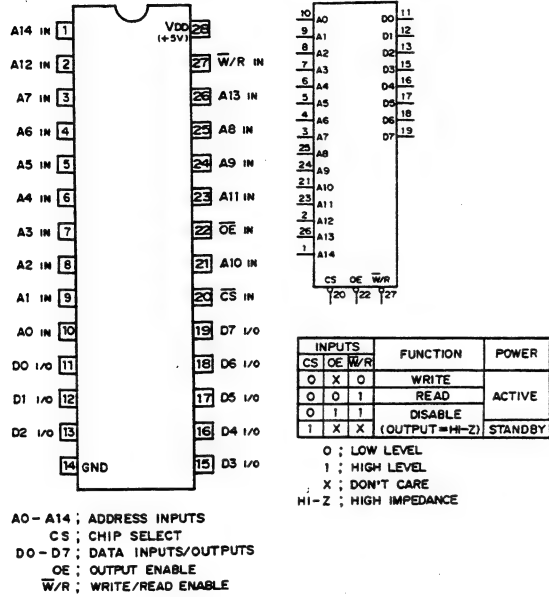

uPD71011G (NEC) FLAT PACKAGE
 C-MOS CLOCK PULSE GENERATOR/DRIVER
 — TOP VIEW —

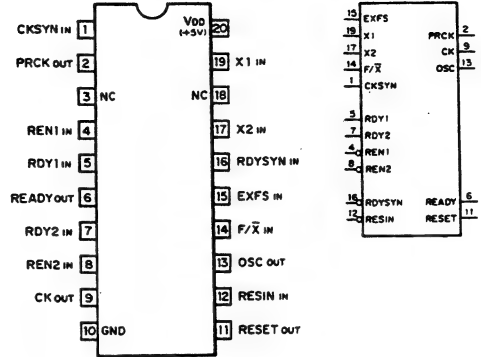

X1, X2 ; CRYSTAL INPUT
 EXFS ; EXTERNAL FREQUENCY SOURCE INPUT
 F/X ; FREQUENCY/CRYSTAL SELECT INPUT
 CK ; PROCESSOR CLOCK OUTPUT
 PRCK ; PERIPHERAL CLOCK OUTPUT
 OSC ; OSCILLATOR OUTPUT
 CKSYN ; CLOCK SYNCHRONIZATION INPUT
 RESIN ; RESET INPUT
 RDY1, RDY2 ; BUS READY INPUT
 REN1, REN2 ; READY ENABLE INPUT
 RDYSYN ; READY SYNCHRONIZATION SELECT INPUT

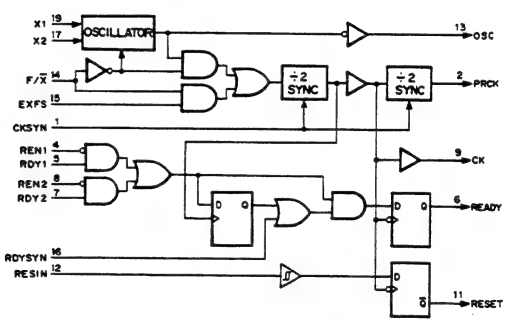

UPD71054G (NEC) FLAT PACKAGE
C-MOS PROGRAMMABLE TIMER COUNTER
— TOP VIEW —

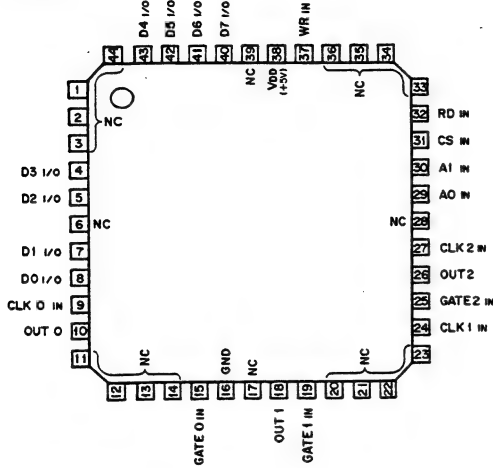

FUNCTION TABLE

| INPUTS | | | | FUNCTION |
|--------|----|----|-------|---------------------|
| CS | RD | WR | A1 AO | |
| 0 | 1 | 0 | 0 | Load Counter No. 0 |
| 0 | 1 | 0 | 1 | Load Counter No. 1 |
| 0 | 1 | 0 | 1 | Load Counter No. 2 |
| 0 | 1 | 0 | 1 | Control Word |
| 0 | 0 | 1 | 0 | Read Counter 0 |
| 0 | 0 | 1 | 0 | Read Counter 1 |
| 0 | 0 | 1 | 0 | Read Counter 2 |
| 0 | 0 | 1 | 1 | No-Operation (HI-Z) |
| 1 | X | X | X | Disable (HI-Z) |
| 0 | 1 | 1 | X | No-Operation (HI-Z) |

D7-D0 : 8-BIT DATA I/O
CLK 0-2 : COUNTER CLOCK
GATE 0-2 : COUNTER GATE
OUT 0-2 : COUNTER OUTPUT
RD : READ COUNTER
WR : WRITE CMD OR DATA
CS : CHIP SELECT
AO, A1 : COUNTER SELECT

0; LOW LEVEL
1; HIGH LEVEL
X; DON'T CARE
HI-Z; HIGH IMPEDANCE

CONTROL WORD FORMAT

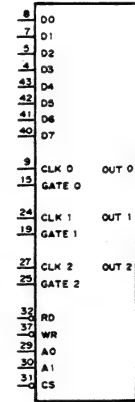
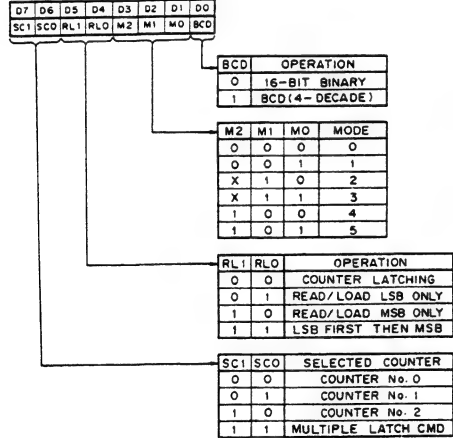

UPD71059G (NEC) FLAT PACKAGE
C-MOS INTERRUPT CONTROL UNIT
— TOP VIEW —

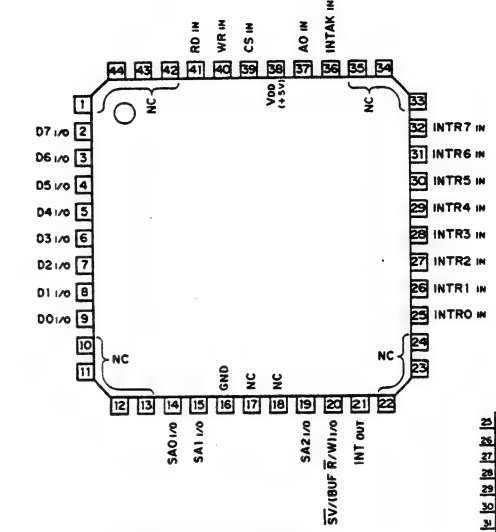

INTR0-INTR7 : INTERRUPT REQUEST INPUTS
D0-D7 : DATA BUS INPUTS/OUTPUTS
CS : CHIP SELECT INPUT
RD : READ STROBE INPUT
WR : WRITE STROBE INPUT
AO : ADDRESS INPUT
INT : INTERRUPT OUTPUT
INTAK : INTERRUPT ACKNOWLEDGE INPUT
SV/BUF R/W : SLAVE/BUFFER READ/WRITE INPUT/OUTPUT
SA0-SA2 : SLAVE ADDRESS INPUTS/OUTPUTS

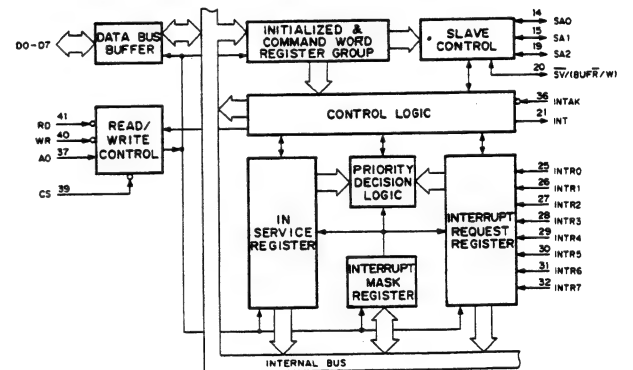
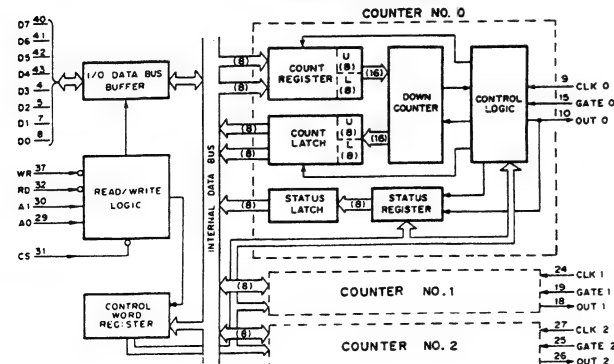
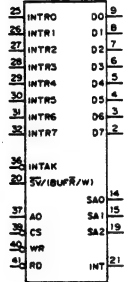



uPD7201 AC (NEC)
 uPD7201 AD (NEC)
 MULTI-PROTOCOL SERIAL CONTROLLER
 — TOP VIEW —

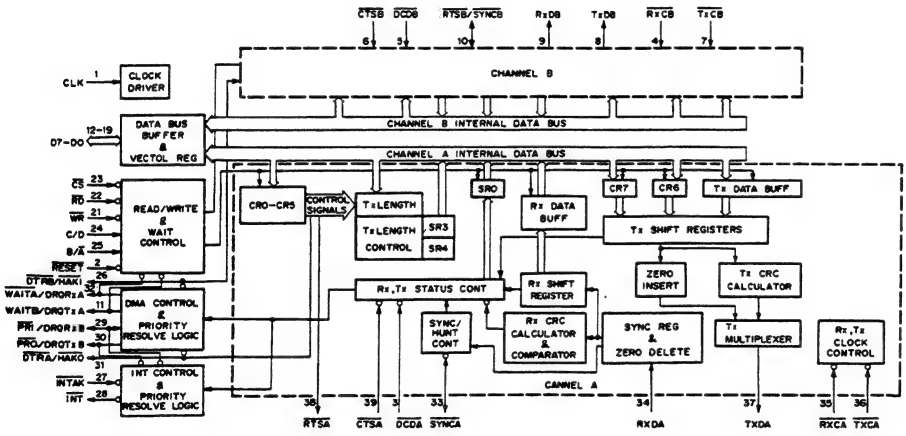
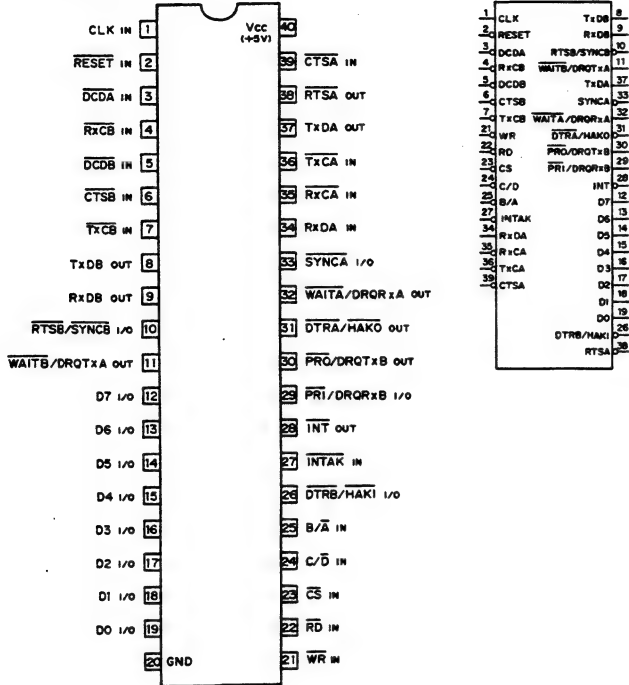

- CLK; SYSTEM CLOCK
- D7-DO; DATA BUS
- CS; CHIP SELECT
- WR; WRITE
- RD; READ
- C/D; CONTROL/DATA
- B/A; CHANNEL B/CHANNEL A
- INT; INTERRUPT REQUEST
- INTAK; INTERRUPT ACKNOWLEDGE
- PRI/DRQRxB; PRIORITY INPUT/DMA REQUEST Rx B
- PRO/DRQTXB; PRIORITY OUTPUT/DMA REQUEST Tx B
- WAITA/DRQRxA; WAIT A/DMA REQUEST Rx A
- WAITB/DRQTXA; WAIT B/DMA REQUEST Tx A
- DTRB/HAKI; DATA TERMINAL READY/HOLD ACKNOWLEDGE INPUT
- DTRA/HAKO; DATA TERMINAL READY/HOLD ACKNOWLEDGE OUTPUT
- RxDA, RxDB; RECEIVE DATA A/B
- TxDA, TxDB; TRANSMIT DATA A/B
- RxCA, RxCB; RECEIVE CLOCK A/B
- TxCA, TxCB; TRANSMIT CLOCK A/B
- SYNCA; SYNCHRONIZATION A
- RTSB/SYNCB; REQUEST TO SEND B/SYNCHRONIZATION B

CHANNEL SELECTION

| B/A | C/D | RD | WR | CS | FUNCTION |
|-----|-----|----|----|----|--|
| 0 | 1 | 0 | 0 | 0 | CHANNEL A CHANNEL B WRITE (TxD) |
| 0 | 1 | 0 | 1 | 0 | CHANNEL A CHANNEL B READ (Rx D) |
| 0 | 1 | 1 | 0 | 0 | CHANNEL A CHANNEL B WRITE (COMMAND/PARAMETER-REGISTER) |
| 0 | 1 | 1 | 1 | 0 | CHANNEL A CHANNEL B READ (STATUS/VECTOR-REGISTER) |

CTS, CTSB; CLEAR TO SEND A/B
 DCDA, DCDB; DATA CARRIER DETECT A/B
 RTSA; REQUEST TO SEND A

μPD7210C (NEC)
N-MOS GENERAL PURPOSE INTERFACE BUS-INTERFACE CONTROLLER
— TOP VIEW —

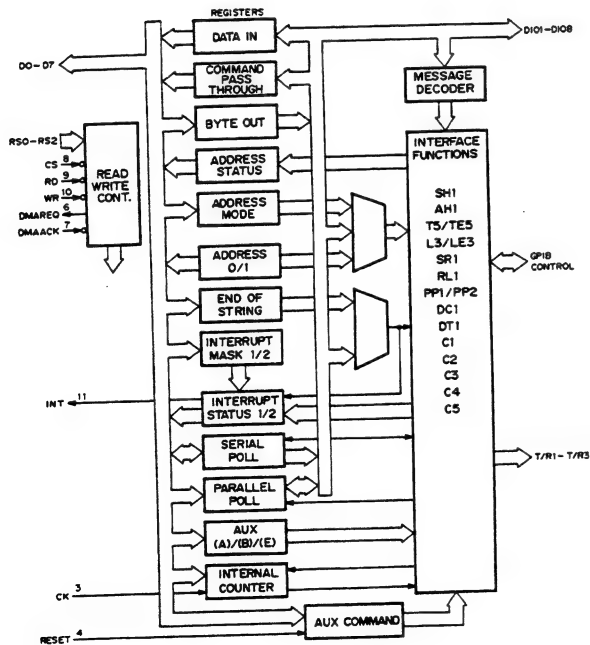
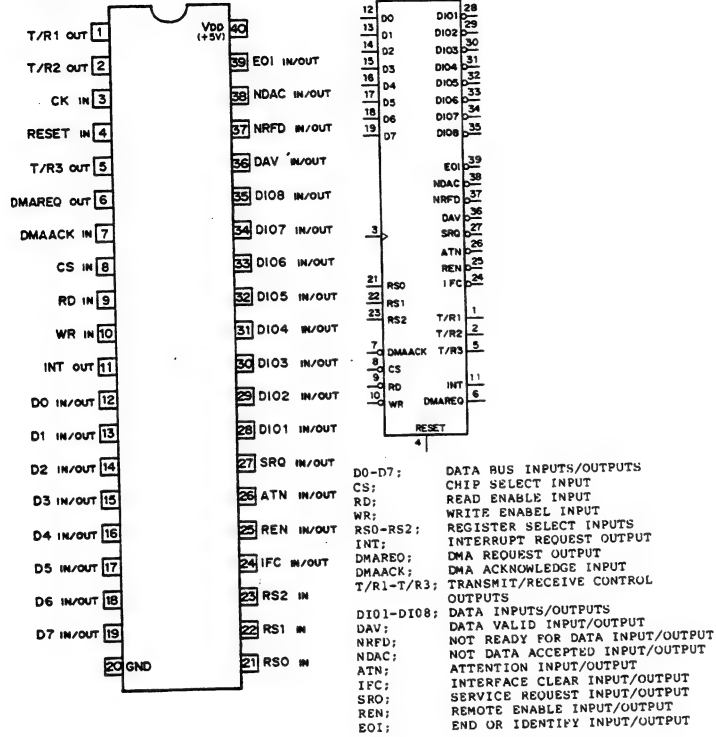

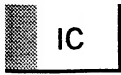

uPD7220AD (NEC) (6MHz)
 uPD7220AD-2 (NEC) (8MHz)
 uPD7220D-1 (NEC) (5MHz)
 N-MOS GRAPHIC DISPLAY CONTROLLER
 — TOP VIEW —

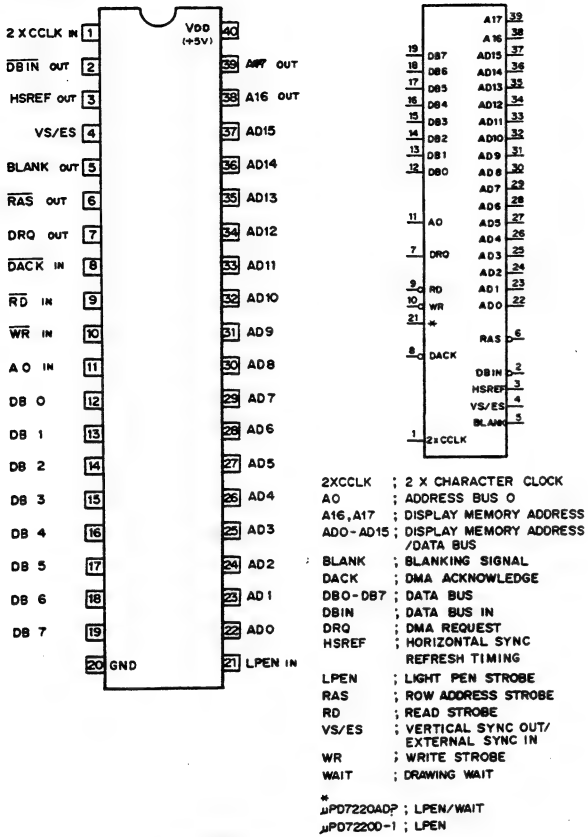

VIDEO MEMORY CONTROL TIMING

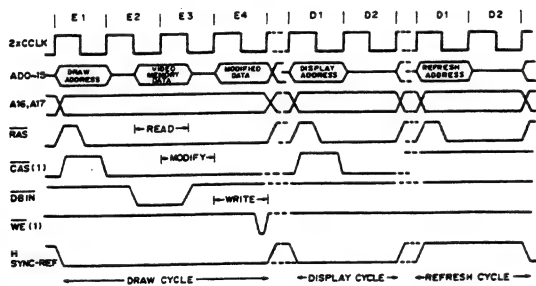

READ TIMING

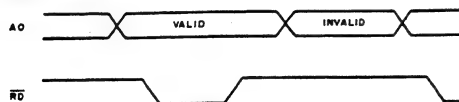

WRITE TIMING

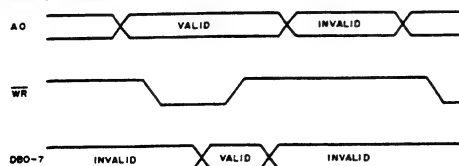

DMA READ TIMING

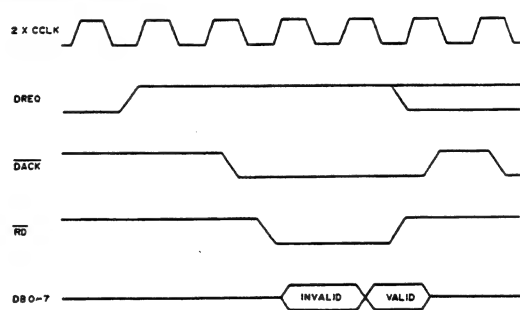

DMA WRITE TIMING

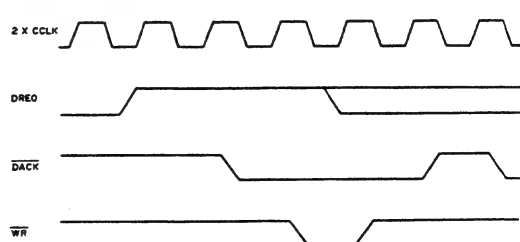

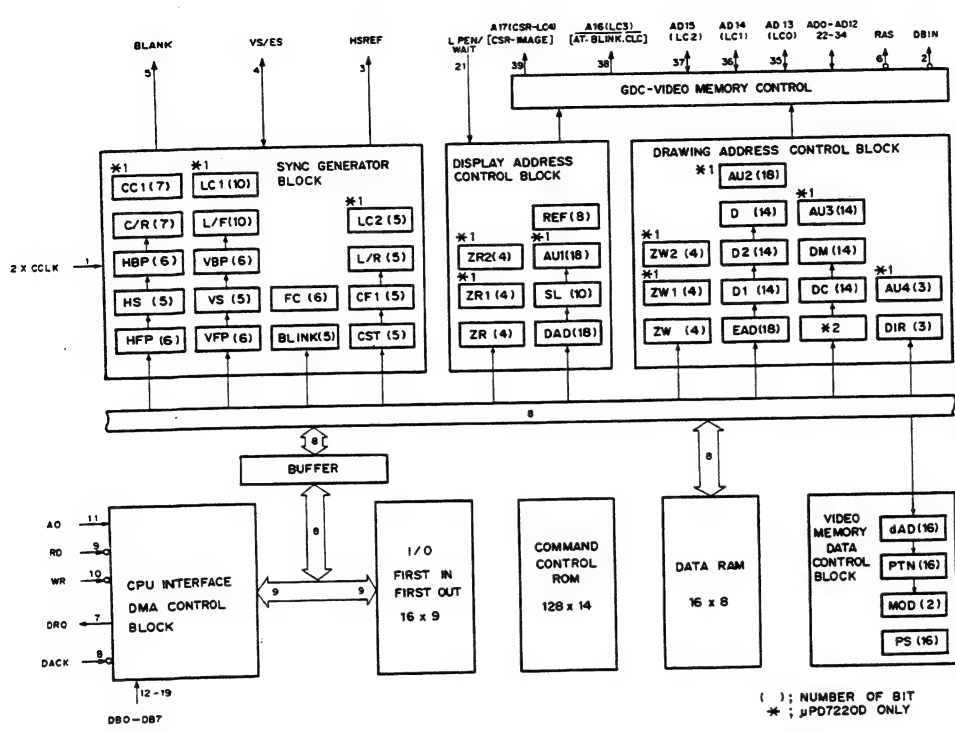

- ABBREVIATIONS OF REGISTER**
- AU1-4 ; ARITHMETIC LOGIC UNIT
 - BLINK ; BLINKING
 - CC1 ; CHARACTER COUNTER
 - CF1 ; FINAL CURSOR LINE
 - C/R ; NUMBER OF CHARACTERS PER ROW
 - CST ; CURSOR START LINE
 - DAD ; DISPLAY ADDRESS
 - dAD ; DOT ADDRESS
 - DIR ; DRAW DIRECTION
 - D1 ; DRAW PARAMETER
 - D2 ; DRAW PARAMETER
 - D ; DRAW PARAMETER
 - DM ; DRAW PARAMETER
 - DC ; DRAW PARAMETER
 - DM ; DRAW PARAMETER
 - EAD ; DRAW ADDRESS
 - FC ; FRAME COUNTER
 - HBP ; HORIZONTAL BACK PORCH
 - HFP ; HORIZONTAL FRONT PORCH
 - HS ; HORIZONTAL SYNC
 - LC1,2 ; LINE COUNTER
 - L/F ; NUMBER OF LINES PER FRAME
 - L/R ; NUMBER OF LINES PER ROW
 - MOD ; MODIFIED DOT MODE
 - P ; PITCH(TOTAL ADDRESS IN HORIZONTAL)
 - PS ; POINTER
 - PTN ; PATTERN
 - REF ; REFRESH COUNTER
 - SL ; SCANNING LINE
 - VBP ; VERTICAL BACK PORCH
 - VFP ; VERTICAL FRONT PORCH
 - VS ; VERTICAL SYNC
 - ZR ; ZOOMING REGISTER
 - ZR1,2 ; ZOOMING REGISTER COUNTER
 - ZW ; ZOOMING DRAW
 - ZW1,2 ; ZOOMING DRAW COUNTER

*1 ; μPD7220D-1 ONLY
 *2 ; μPD7220ADP;P(9)
 μPD7220D-1 ;P(8)

() ; NUMBER OF BIT
 * ; μPD7220D ONLY



μPD7506CT (NEC)
C-MOS SINGLE CHIP 4-BIT MICROCOMPUTER
 — TOP VIEW —

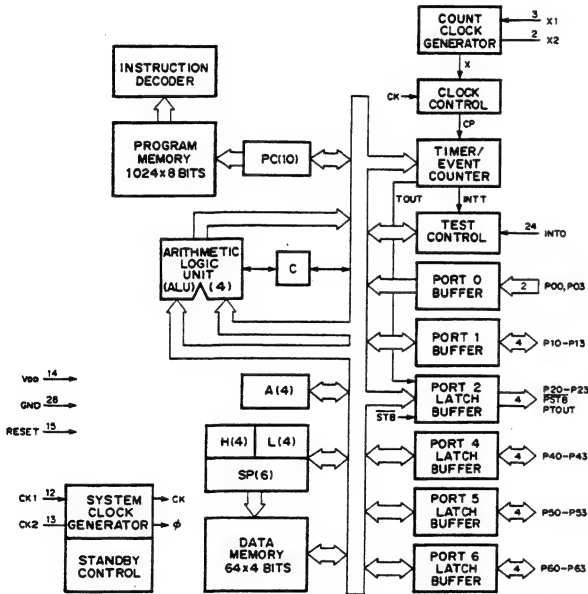
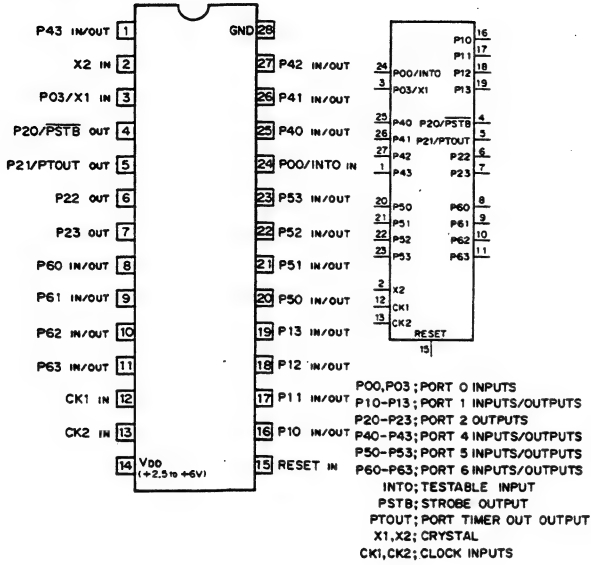

uPD78C10G
C-MOS SINGLE CHIP 8-BIT MICROPROCESSOR WITH A/D CONVERTER
— TOP VIEW —

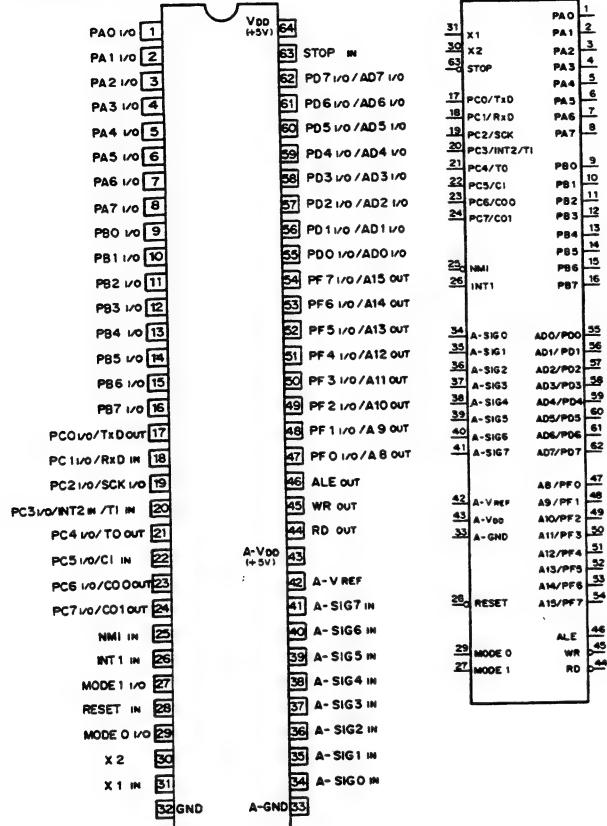

- PA0-7; INPUT/OUTPUT PORT A
- PB0-7; INPUT/OUTPUT PORT B
- PC0-7; INPUT/OUTPUT PORT C

- TxD; SERIAL DATA OUTPUT
- RxD; SERIAL DATA INPUT
- SCK; SERIAL CLOCK I/O
- INT2/T1; MASKABLE INTERRUPT REQUEST 2 IN/TIMER INPUT
- TO; TIMER OUTPUT
- C1; COUNTER INPUT
- CO0; COUNTER OUTPUT 0
- CO1; COUNTER OUTPUT 1

- PDO-7/AD0-7; I/O PORT D / ADDRESS/DATA BUS
- PFO-7/A8-15; I/O PORT F / ADDRESS BUS

- ALE; ADDRESS LATCH ENABLE OUTPUT
- RD; READ STROBE OUTPUT
- WR; WRITE STROBE OUTPUT
- MODE 0; MEMORY MODE 0 INPUT/OUTPUT
- MODE 1; MEMORY MODE 1 INPUT/OUTPUT
- RESET; SYSTEM RESET INPUT
- STOP; SYSTEM STOP INPUT
- NMI; NON-MASKABLE INTERRUPT REQUEST INPUT
- INT1; MASKABLE INTERRUPT REQUEST 1 INPUT
- X1, X2; EXTERNAL CRYSTAL, X1; SYSTEM CLOCK INPUT

- A-SIG 0 TO 7; ANALOG INPUTS
- A-VREF; REFERENCE VOLTAGE

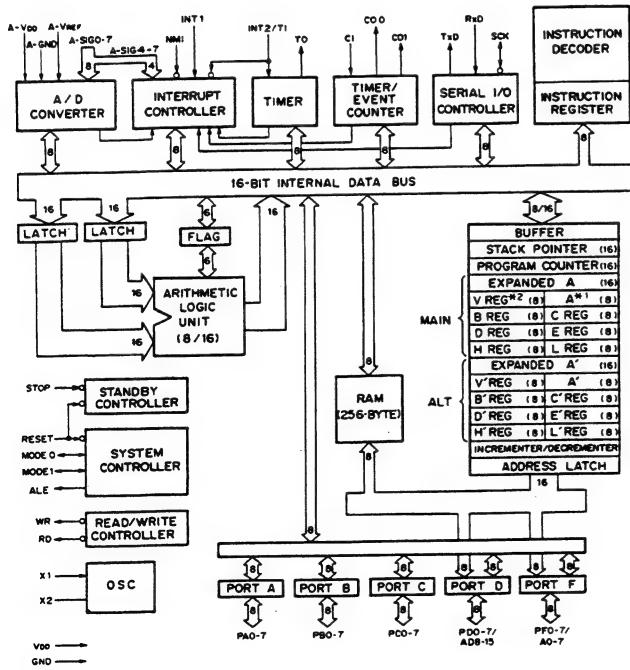

X1; ACCUMULATOR
X2; WORKING REGISTER VECTOR REG.

PROM

HN27C64G-20 (HITACHI) (ACCESS TIME = 200 nS)
 MBM27C64-20 (FUJITSU) (ACCESS TIME = 200 nS)
 MBM27C64-25 (FUJITSU) (ACCESS TIME = 250 nS)
 MBM27C64-30 (FUJITSU) (ACCESS TIME = 300 nS)
 C-MOS 64K (8K-8) ERASABLE PROM WITH 3-STATE OUTPUTS
 - TOP VIEW -

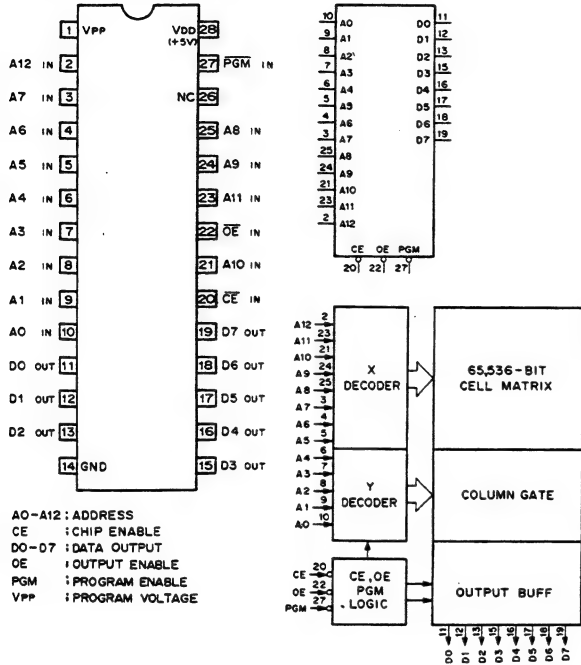

A0-A12 : ADDRESS
 CE : CHIP ENABLE
 D0-D7 : DATA OUTPUT
 OE : OUTPUT ENABLE
 PGM : PROGRAM ENABLE
 VPP : PROGRAM VOLTAGE

MBM27C128-25 (FUJITSU) (ACCESS TIME = 250ns)
 CMOS 131,072-BIT EPROM
 - TOP VIEW -

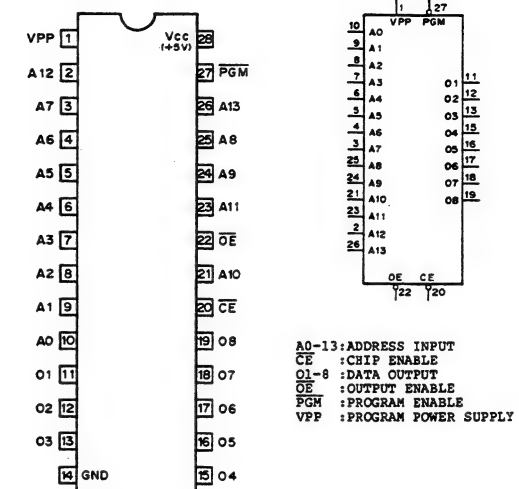

A0-13: ADDRESS INPUT
 CE : CHIP ENABLE
 O1-8 : DATA OUTPUT
 OE : OUTPUT ENABLE
 PGM : PROGRAM ENABLE
 VPP : PROGRAM POWER SUPPLY

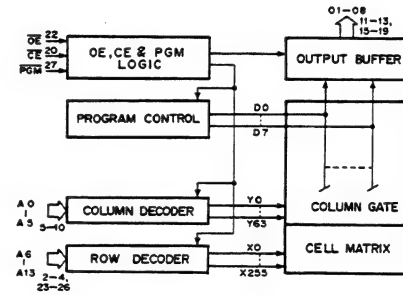

| MODE | TERMINAL | DATA OUTPUT | CE | OE | PGM | VPP |
|-----------------|----------------|-------------|----|----|------|-----|
| READ | DATA OUT | 0 | 0 | 1 | +5V | |
| OUTPUT DISABLE | HIGH IMPEDANCE | 0 | 1 | 1 | +5V | |
| OUTPUT DISABLE | HIGH IMPEDANCE | 0 | 0 | 0 | +5V | |
| STANDBY | HIGH IMPEDANCE | 1 | X | X | +5V | |
| PROGRAM | DATA IN | 0 | 1 | 0 | +21V | |
| PROGRAM VERIFY | DATA OUT | 0 | 0 | 1 | +21V | |
| PROGRAM INHIBIT | HIGH IMPEDANCE | 1 | X | X | +21V | |

0:LOW LEVEL
 1:HIGH LEVEL
 X:DON'T CARE

MBM27C256-20 (FUJITSU) (ACCESS TIME = 200 nS)
 MBM27C256-25 (FUJITSU) (ACCESS TIME = 250 nS)
 TCS7256D-25 (TOSHIBA) (ACCESS TIME = 250 nS)
 uPD27C256AD-12 (NEC) (ACCESS TIME = 120 nS)
 C-MOS 256K (32Kx8) ERASABLE PROM WITH 3-STATE OUTPUTS
 — TOP VIEW —

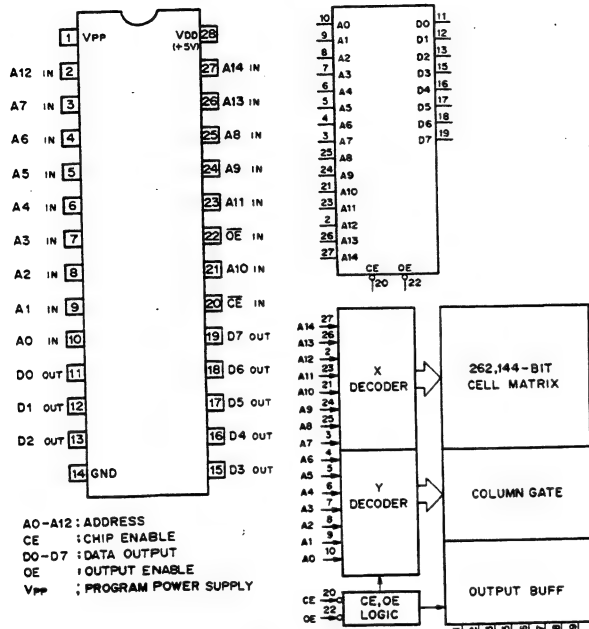

| An | CE | OE | Vpp | Dn | FUNCTION |
|----|----|----|------|-------|----------------|
| An | 0 | 0 | +5V | D OUT | READ |
| An | 0 | 1 | +5V | HI-Z | OUTPUT DISABLE |
| X | 1 | X | +5V | HI-Z | STANDBY |
| An | 0 | 1 | +21V | D IN | PGM |
| An | 0 | 0 | +21V | D OUT | PGM VERIFY |
| X | 1 | X | +21V | HI-Z | PGM INH |

0: LOW LEVEL
 1: HIGH LEVEL
 X: DON'T CARE
 HI-Z: HIGH IMPEDANCE

MBM27C512-25 (FUJITSU) (ACCESS TIME 250nS)
 MBM27C512-30 (FUJITSU) (ACCESS TIME 300nS)
 C-MOS 512K-8 BIT ERASABLE ROM
 — TOP VIEW —

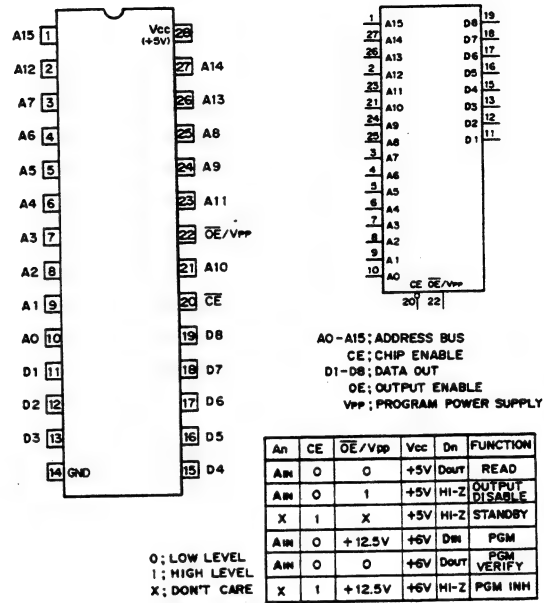

A0-A15: ADDRESS BUS
 CE: CHIP ENABLE
 D1-D8: DATA OUT
 OE: OUTPUT ENABLE
 Vpp: PROGRAM POWER SUPPLY

| An | CE | OE/Vpp | Vcc | Dn | FUNCTION |
|----|----|--------|-----|------|----------------|
| An | 0 | 0 | +5V | Dout | READ |
| An | 0 | 1 | +5V | HI-Z | OUTPUT DISABLE |
| X | 1 | X | +5V | HI-Z | STANDBY |
| An | 0 | +12.5V | +6V | Din | PGM |
| An | 0 | 0 | +6V | Dout | PGM VERIFY |
| X | 1 | +12.5V | +6V | HI-Z | PGM INH |

0: LOW LEVEL
 1: HIGH LEVEL
 X: DON'T CARE

MBM27C32A-20 (FUJITSU) (ACCESS TIME = 200 nS)
 MBM27C32A-25 (FUJITSU) (ACCESS TIME = 250 nS)
 MBM27C32A-30 (FUJITSU) (ACCESS TIME = 300 nS)
 C-MOS 32K (4Kx8) UV EPROM
 — TOP VIEW —

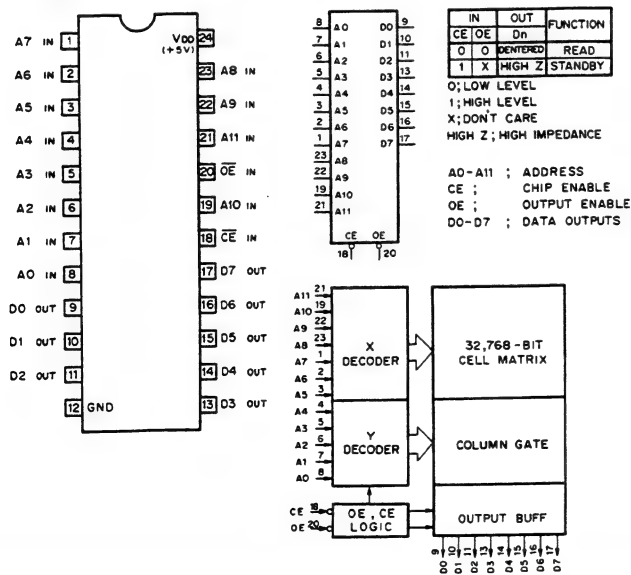

| IN | OUT | FUNCTION |
|----|-----|----------------|
| CE | OE | Dn |
| 0 | 0 | ENTERED READ |
| 1 | X | HIGH Z STANDBY |

0: LOW LEVEL
 1: HIGH LEVEL
 X: DON'T CARE
 HIGH Z: HIGH IMPEDANCE

A0-A11: ADDRESS
 CE: CHIP ENABLE
 OE: OUTPUT ENABLE
 D0-D7: DATA OUTPUTS

VP16V8E (VLSI TECHNOLOGY)
 C-MOS GENERIC ARRAY LOGIC
 — TOP VIEW —

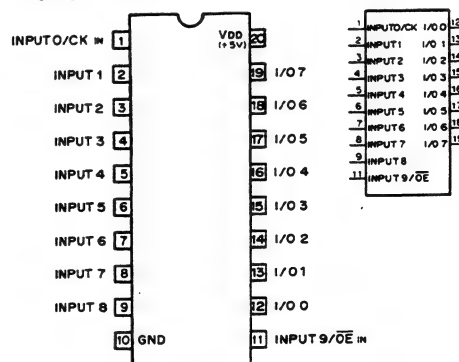

* ABOVE DIAGRAM SHOWS CONDITIONS BEFORE WRITING OF DATA.

CXQ70108-5 (SONY)
 CXQ70108-8 (SONY)
 CXQ70108D-8 (SONY)
 CXQ70108P-8 (SONY)
 uPD70108D-5 (NEC)
 uPD70108D-8 (NEC)
 C-MOS 8-BIT MICROPROCESSOR
 - TOP VIEW -

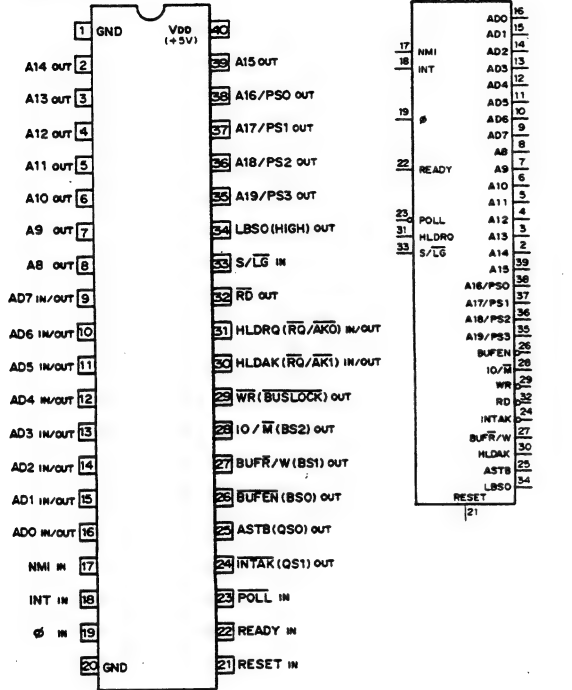

| PIN No. | FUNCTION | |
|---------|-----------------|----------------|
| | S/LG=HIGH LEVEL | S/LG=LOW LEVEL |
| 24 | INTAK | Q51 |
| 25 | ASTB | Q50 |
| 26 | BUFEN | BS0 |
| 27 | BUF R/W | BS1 |
| 28 | IO/M | BS2 |
| 29 | WR | BUSLOCK |
| 30 | HLDRAK | RQ/AK1 |
| 31 | HLDRAK | RQ/AK0 |
| 34 | LBSO | HIGH LEVEL |

A8-A15; ADDRESS BUS OUTPUTS
 ADO-AD7; ADDRESS/DATA BUS INPUTS/OUTPUTS
 NMI; NON-MASKABLE INTERRUPT INPUT
 INT; MASKABLE INTERRUPT INPUT
 phi; CLOCK INPUT
 INTAK; INTERRUPT ACKNOWLEDGE OUTPUT
 ASTB; ADDRESS STROBE OUTPUT
 BUFEN; BUFFER ENABLE OUTPUT
 BUFR/W; BUFFER READ/WRITE OUTPUT
 IO/M; IO/MEMORY OUTPUT
 WR; WRITE STROBE OUTPUT
 HLDRAK; HOLD ACKNOWLEDGE OUTPUT
 HLDRAK; HOLD REQUEST INPUT
 RD; READ STROBE OUTPUT
 S/LG; SMALL/LARGE INPUT
 LBSO; LATCHED BUS STATUS 0 OUTPUT
 A16/PSO-A19/PS3; ADDRESS BUS/PROCESSOR STATUS OUTPUTS
 Q50, 51; QUEUE STATUS OUTPUTS
 BS0-BS2; BUS STATUS OUTPUTS
 BUSLOCK; BUS LOCK OUTPUT
 RQ/AK0, 1; HOLD REQUEST/ACKNOWLEDGE INPUTS/OUTPUTS

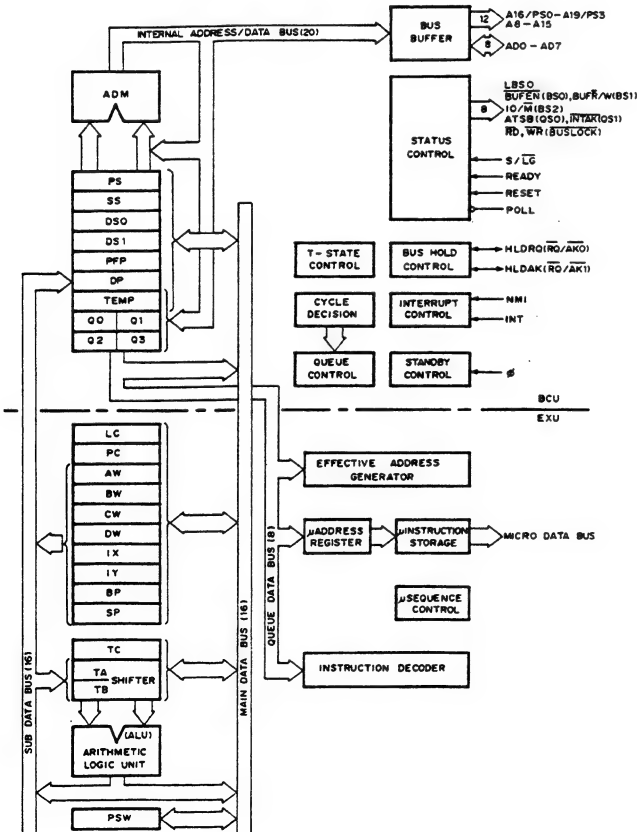

uPD72001 C (NEC)
C-MOS ADVANCED MULTI-PROTOCOL SERIAL CONTROLLER
— TOP VIEW —

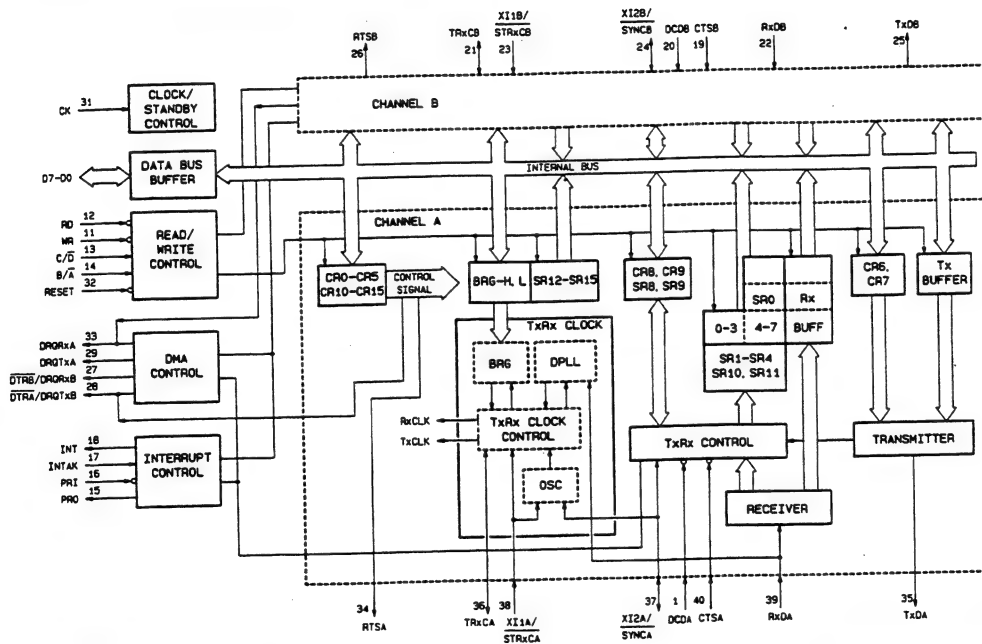
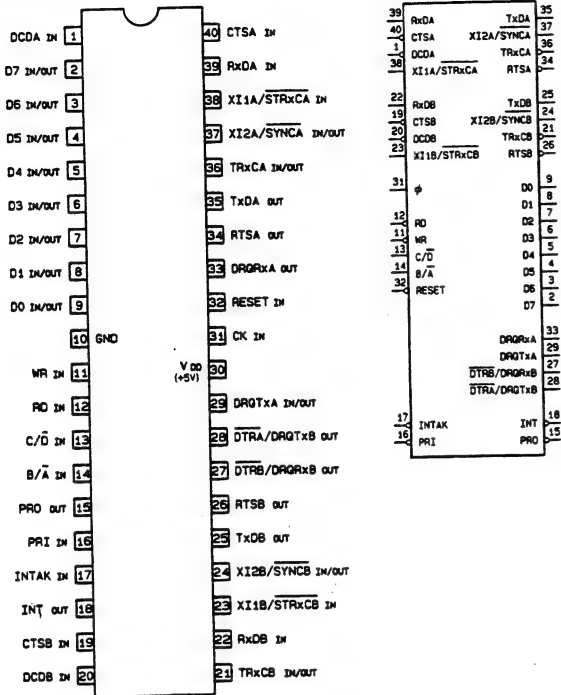

| INPUTS | | | | FUNCTION | |
|--------|----|-----|-----|-----------|--------------------------|
| WR | RD | B/A | C/D | CHANNEL | FUNCTION |
| 0 | 1 | 0 | 0 | CHANNEL A | WRITE (TxD) |
| 1 | 0 | 1 | 0 | CHANNEL B | WRITE (TxD) |
| 1 | 0 | 0 | 0 | CHANNEL A | READ (RxD) |
| 1 | 0 | 1 | 0 | CHANNEL B | READ (RxD) |
| 0 | 1 | 0 | 1 | CHANNEL A | WRITE (CONTROL REGISTER) |
| 0 | 1 | 1 | 1 | CHANNEL B | WRITE (CONTROL REGISTER) |
| 1 | 0 | 0 | 1 | CHANNEL A | READ (STATUS REGISTER) |
| 1 | 0 | 1 | 1 | CHANNEL B | READ (STATUS REGISTER) |
| 1 | 1 | X | X | | HIGH-IMPEDANCE |
| 0 | 0 | X | X | | INHIBIT |

0: LOW LEVEL
1: HIGH LEVEL
X: DON'T CARE

CK : SYSTEM CLOCK INPUT
WR : WRITE ENABLE INPUT
RD : READ ENABLE INPUT
B/A : CHANNEL B/A SELECT INPUT
C/D : CONTROL/DATA SELECT INPUT
D0-D7 : DATA BUS INPUTS/OUTPUTS
INT : INTERRUPT OUTPUT
INTAK : INTERRUPT ACKNOWLEDGE INPUT
PRI : PRIORITY INPUT
DRQTxA : DMA REQUEST TxA OUTPUT
DRQRxA : DMA REQUEST RxA OUTPUT
PRO : PRIORITY OUTPUT

DTRA/DRQTxB : DATA TERMINAL READY A/DMA REQUEST TxB OUTPUT
DTRB/DRQRxB : DATA TERMINAL READY B/DMA REQUEST RxB OUTPUT
CTS.A, CTS.B : CLEAR TO SEND A/B INPUT
DCDA, DCDB : DATA CARRIER DETECT A/B INPUT
RTSA, RTSB : REQUEST TO SEND A/B INPUT
RESET : RESET INPUT

SECTION D

REPLACEABLE PARTS AND OPTIONAL FIXTURE

補修用部品注意事項

(1) 安全重要部品

回路図、分解図、電気部品表中、 Δ 印及び  で囲まれた部品は安全性を維持するために重要な部品です。従ってこれらの部品を交換するときには必ず指定の部品と交換して下さい。

(2) 部品の共通化

ソニーから供給される部品はセットに実装されているものと異なることがあります。これは部品の共通化、改良等によるものです。

分解図や電気部品表には現時点での共通化された部品が記載されています。

(3) 部品の変更

部品の変更に関する情報は第E章「CHANGED PARTS」を参照して下さい。

(4) 部品の在庫

部品表のSP (Supply code) 欄に \circ で示される部品は交換頻度が低い部品ですので在庫していないことがあり、納期が長くなることがあります。

(5) コンデンサー、インダクター、抵抗の単位

回路図、分解図、電気部品表中、特に明記したものを除き、下記の単位は省略されています。

コンデンサー: μF

インダクター: μH

抵抗: Ω

Notes on Repair Parts

(1) Safety Related Components Warning

Components identified by shading marked with Δ on the schematic diagrams, exploded views and electrical spare parts list are critical to safe operation. Replace these components with Sony parts whose part numbers appear in this manual or in service bulletins and service manual supplements published by Sony.

(2) Standardization of Parts

Repair parts supplied from Sony Parts Center may not be always identical with the parts which actually in use due to "accommodating the improved parts and/or engineering changes" or "standardization of genuine parts".

This manual's exploded views and electrical spare parts list are indicating the part numbers of "the standardized genuine parts at present".

(3) Change of Parts

Regarding engineering parts changes, refer to Section E. "CHANGED PARTS".

(4) Stock of Parts

Parts marked with " \circ " SP (Supply Code) column of the spare parts list are not normally required for routine service work. Orders for parts marked with " \circ " will be processed, but allow for additional delivery time.

(5) Units for Capacitors, Inductors and Resistors

The following units are assumed in schematic diagrams, electrical parts list and exploded views unless otherwise specified.

Capacitors: μF

Inductors: μH

Resistors: ohm

MAIN ASS' Y

MAIN ASSEMBLY, DVR-1000

| No. | Part No. | SP | Description |
|-----|--------------|----|---------------------------------|
| A01 | A-6025-112-A | o | COMPLETE PCB, SE-47 |
| X01 | X-3715-496-1 | o | HANDLE ASSY |
| X02 | X-3715-356-1 | o | PLATE ASSY, TOP |
| X03 | X-4836-202-X | s | FOOT ASSY |
| 301 | 3-642-047-00 | o | STOP, HANDLE |
| 302 | 3-715-307-01 | o | STOPPER, UPPER LID |
| 303 | 3-715-308-01 | o | SPACER, UPPER LID |
| 304 | 3-715-612-01 | o | PLATE, ORNAMENTAL |
| 305 | 3-715-636-01 | o | PLATE (LEFT), ADJUSTMENT |
| 306 | 3-715-637-01 | o | PLATE (RIGHT), ADJUSTMENT |
| 307 | 3-715-639-01 | o | PANEL (LEFT), SIDE |
| 308 | 3-715-640-01 | o | PANEL (RIGHT), SIDE |
| 309 | 3-715-673-01 | o | PLATE, BOTTOM |
| 310 | 3-715-698-01 | o | PLATE, OUTER, LEFT |
| 311 | 3-715-699-01 | o | PLATE, OUTER, RIGHT |
| 312 | 3-715-808-02 | o | COVER, SE-47 PC BOARD |
| 313 | 3-716-720-01 | o | PLATE, SHIELD, RF |
| 701 | 7-624-106-04 | s | STOP RING 3.0, TYPE-E |
| 702 | 7-682-547-09 | s | SCREW, +B 3X6 |
| 703 | 7-682-562-04 | s | SCREW, +B 4X10 |
| 704 | 7-682-648-09 | s | SCREW, +PS 3X8 |
| 705 | 7-682-660-09 | s | SCREW, +PS 4X6 |
| 706 | 7-682-666-09 | s | SCREW, +PS 4X20 |
| 707 | 7-682-903-11 | s | SCREW, +PWH 3X6 |
| 708 | 7-682-947-01 | s | SCREW, +PSW 3X6 |
| 709 | 7-682-950-01 | s | SCREW, +PSW 3X12 |
| 710 | 7-685-645-79 | s | SCREW, +BVTP 3X6, TYPE2 SLIT |
| 711 | 7-688-003-01 | s | W3, SMALL |
| 712 | 7-682-948-01 | s | SCREW, +PSW 3X8 |

MAIN ASS'Y MAIN ASS'Y

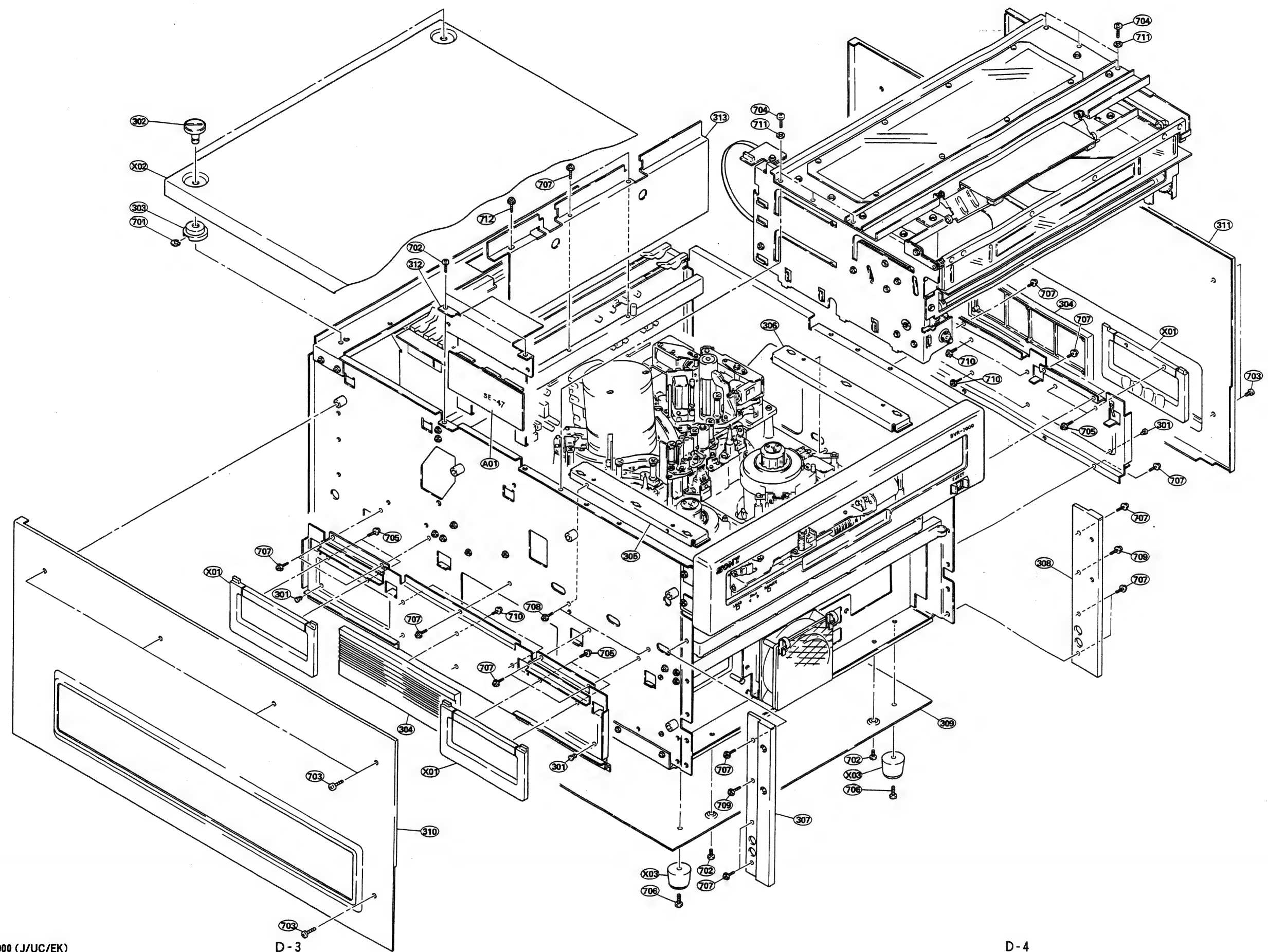

FRONT PANEL ASS'Y FRONT PANEL ASS'Y

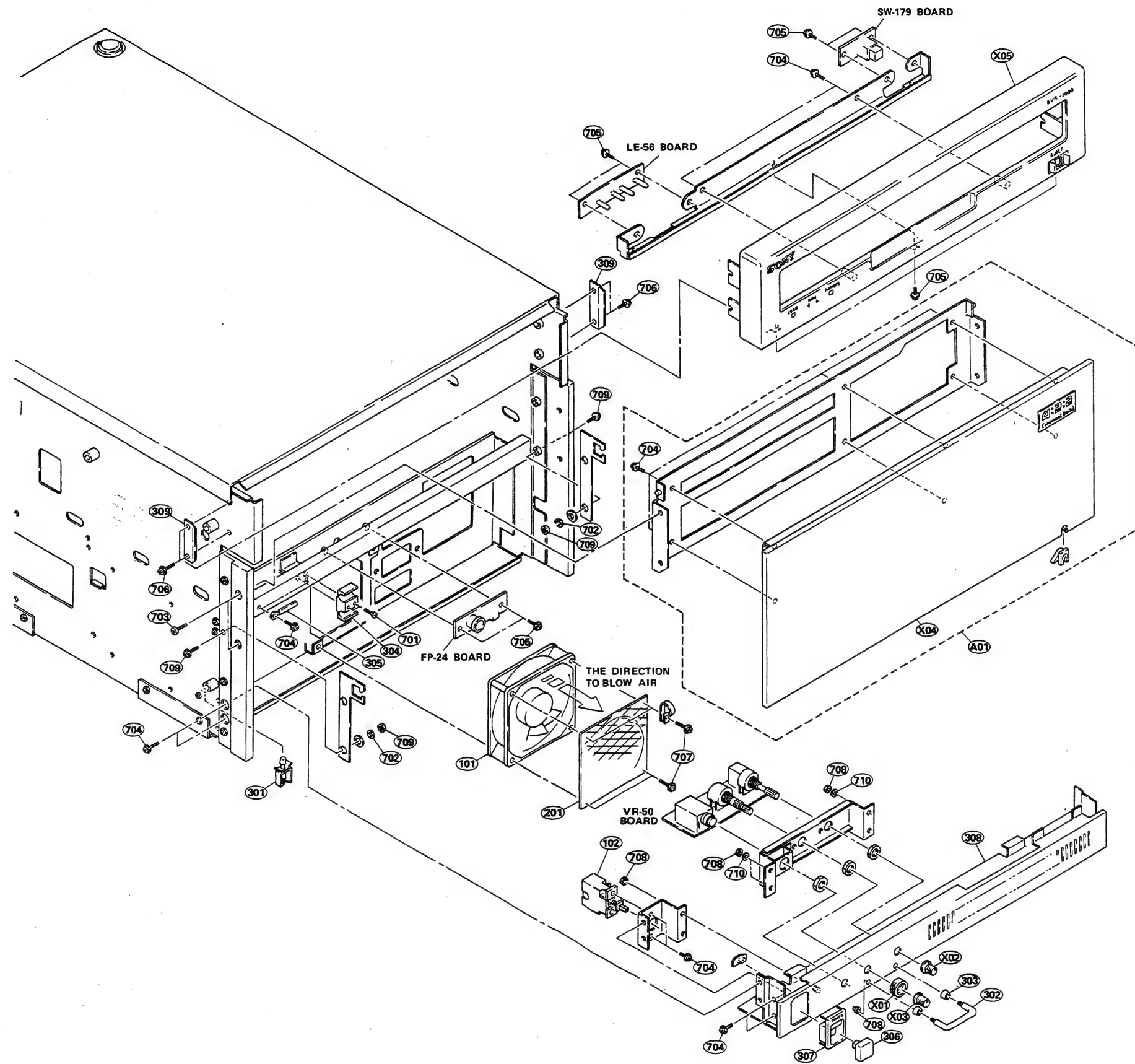

FRONT PANEL ASSEMBLY, DVR-1000

| No. | Part No. | SP | Description |
|-----|--------------|----|-------------------------|
| A01 | A-6003-028-A | o | PANEL (A) ASSY, BLANK |
| X01 | X-3715-497-1 | s | KNOB (W) ASSY, VOLUME |
| X02 | X-3715-499-1 | s | KNOB (1) ASSY, VOLUME |
| X03 | X-3715-498-1 | s | KNOB (2) ASSY, VOLUME |
| X04 | X-3715-395-1 | o | PANEL (A) ASSY, BLANK |
| X05 | X-3715-396-1 | o | ESCUTCHEON ASSY |
| 101 | 1-541-436-11 | s | MOTOR, DC FAN |
| 102 | 1-570-052-11 | s | SWITCH, PUSH (AC POWER) |
| 201 | 2-252-609-00 | o | COVER, FAN |
| 301 | 3-655-214-00 | o | CLIP, CABLE |
| 302 | 3-657-653-00 | o | ARM, GUARD |
| 303 | 3-657-654-00 | o | RING, ORNAMENTAL |
| 304 | 3-686-244-01 | o | CLAMP, CABLE |
| 305 | 3-701-822-00 | o | HOLDER, WIRE |
| 306 | 3-715-610-01 | s | KNOB, PS |
| 307 | 3-715-611-03 | o | GUARD, PS |
| 308 | 3-715-819-01 | o | PANEL, FRONT |
| 309 | 3-716-713-01 | o | STOPPER, ESCUTCHEON |
| 701 | 7-621-773-95 | s | SCREW, +B 2.6X6 |
| 702 | 7-623-208-22 | s | SW3, TYPE-2 |
| 703 | 7-682-548-09 | s | SCREW, +B 3X8 |
| 704 | 7-682-903-11 | s | SCREW, +PWH 3X6 |
| 705 | 7-682-947-01 | s | SCREW, +PSW 3X6 |
| 706 | 7-682-948-01 | s | SCREW, +PSW 3X8 |
| 707 | 7-682-969-01 | s | SCREW, +PSW 4X35 |
| 708 | 7-684-023-04 | s | N 3, TYPE-2 |
| 709 | 7-686-250-01 | s | SCREW, +PWH 3X12 |
| 710 | 7-688-003-11 | s | W3, MIDDLE |

FUNCTION CONTROL PANEL ASS' Y

FUNCTION CONTROL PANEL ASSEMBLY, DVR-1000

| No. | Part No. | SP | Description |
|-----|--------------|----|------------------------------|
| A01 | A-6017-142-A | o | COMPLETE PCB, PS-139 |
| A02 | A-6017-143-A | o | COMPLETE PCB, SW-157 |
| A03 | A-6017-145-A | o | COMPLETE PCB, CP-106 |
| X01 | X-3715-386-2 | o | PLATE ASSY, BOTTOM |
| X02 | X-3715-387-1 | o | PANEL ASSY, CONTROL |
| 101 | 1-464-765-12 | s | DISPLAY UNIT, EL |
| 102 | 1-464-779-11 | s | ENCODER, ROTARY |
| 103 | 1-515-618-12 | s | CLUTCH, ELECTOMAGNETIC |
| 301 | 3-673-694-00 | o | HOLDER, DME |
| 302 | 3-714-595-01 | o | KNOB, DIAL |
| 303 | 3-714-596-01 | o | DIAL |
| 304 | 3-715-861-01 | o | SHEET, PANEL |
| 305 | 3-715-863-04 | o | SUPPORT, PC BOARD |
| 306 | 3-715-864-01 | s | KEY, TEN |
| 307 | 3-715-865-01 | s | KEY, SELECT |
| 308 | 3-715-866-01 | s | KEY, MENU |
| 309 | 3-715-869-01 | o | KNOB, VOLUME |
| 701 | 7-621-759-45 | s | SCREW, +PSW 2.6X6 |
| 702 | 7-682-947-01 | s | SCREW, +PSW 3X6 |
| 703 | 7-682-948-01 | s | SCREW, +PSW 3X8 |
| 704 | 7-683-238-01 | s | SET SCREW, FLAT POINT 3X4 |
| 705 | 7-685-533-14 | s | SCREW, +BTP 2.6X6 |
| 706 | 7-685-903-11 | s | SCREW, +PTPWH 3X6 |

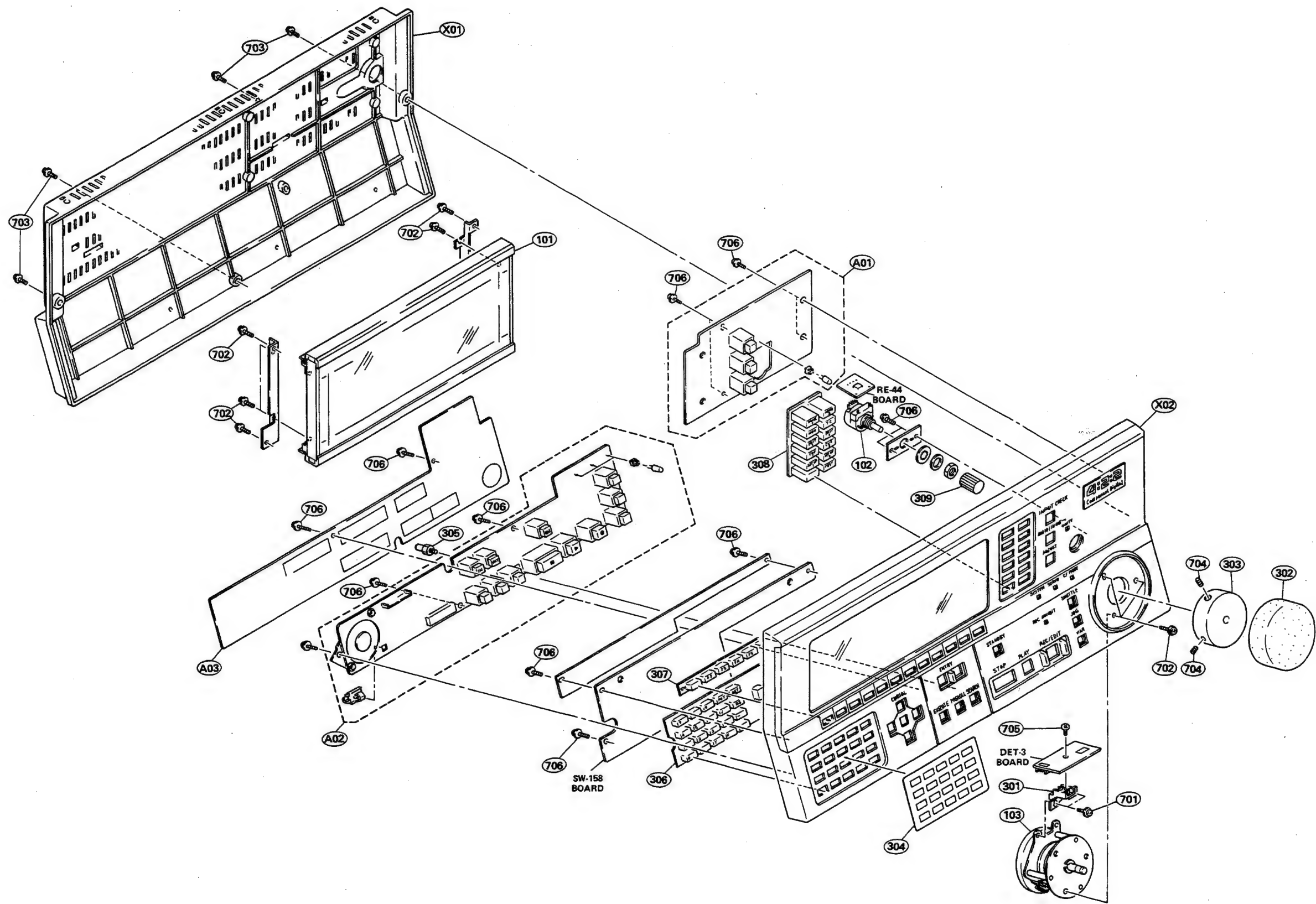

REAR PANEL ASS'Y REAR PANEL ASS'Y

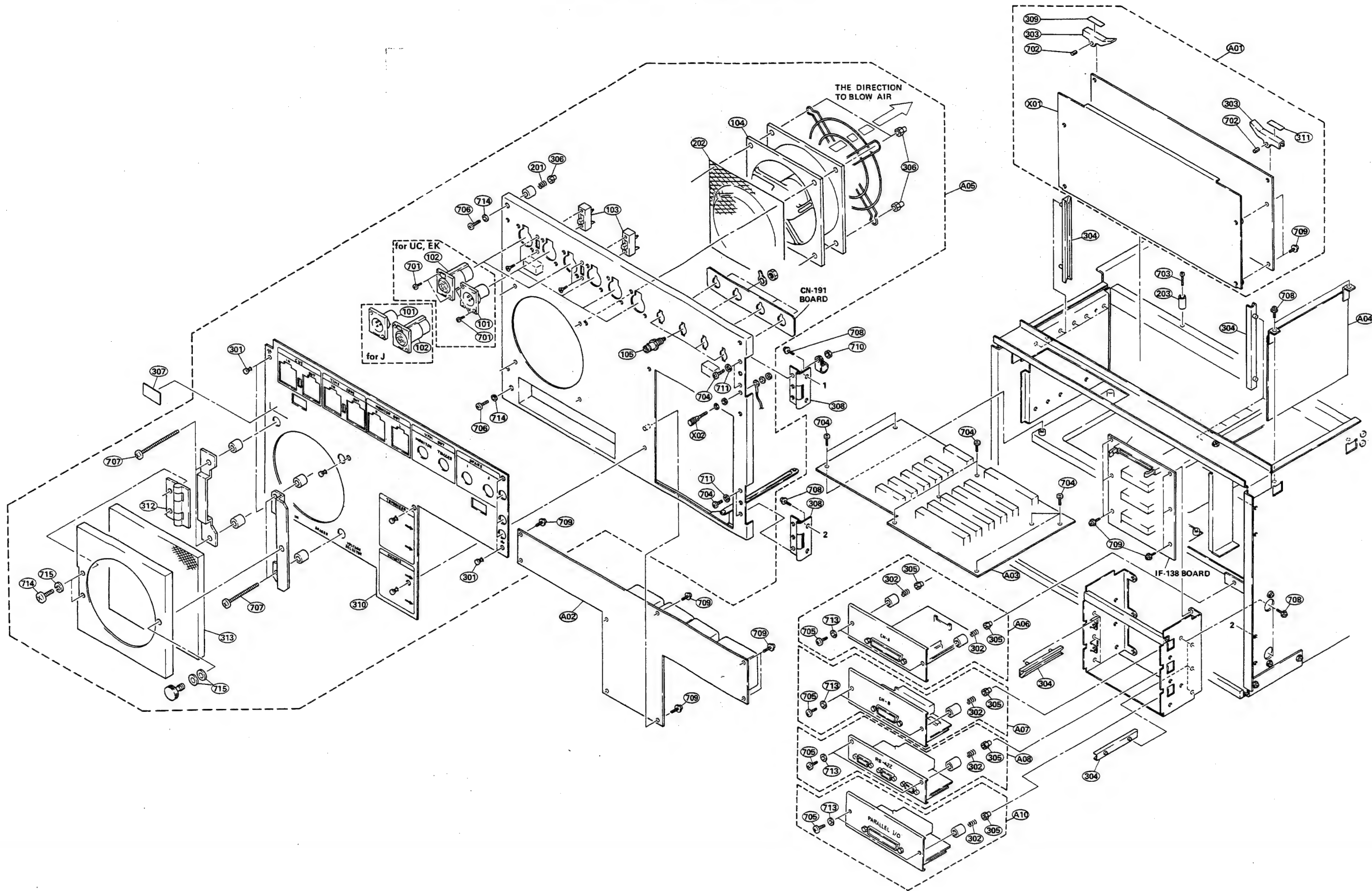

REAR PANEL ASSEMBLY, DVR-1000

(REAR PANEL ASSEMBLY, DVR-1000)

| No. | Part No. | SP | Description | No. | Part No. | SP | Description |
|-----|--------------|----|-----------------------------------|-----|--------------|----|-------------------------------|
| A01 | A-6011-114-A | o | COMPLETE PCB, RF-15 | 310 | 3-715-703-04 | o | LABEL, REAR PANEL |
| | A-6013-084-A | o | COMPLETE PCB, AE-05 | 311 | 3-715-590-71 | o | LABEL, SERIAL NUMBER (SY-124) |
| | A-6015-104-A | o | COMPLETE PCB, CD-35 | 312 | 3-651-803-00 | o | HINGE, PC BOARD |
| | A-6015-105-A | o | COMPLETE PCB, RS-23 | 313 | 3-735-190-01 | s | FILTER, AIR |
| | A-6017-140-A | o | COMPLETE PCB, SP-01 | 701 | 7-621-770-67 | s | SCREW, +B 2.6X6 |
| | A-6017-150-A | o | COMPLETE PCB, SY-124 | 702 | 7-626-320-11 | o | PIN, SPRING 3X8 |
| A02 | A-6013-082-A | o | COMPLETE PCB, LO-05 | 703 | 7-628-254-95 | s | SCREW, +PS 2.6X14 |
| A03 | A-6025-108-A | o | COMPLETE PCB, MB-133 | 704 | 7-682-547-09 | s | SCREW, +B 3X6 |
| A04 | A-6025-113-A | o | COMPLETE PCB, TR-40 | 705 | 7-682-565-09 | s | SCREW, +B 4X16 |
| A05 | A-6032-065-B | o | PANEL (1) ASSY, REAR (for J) | 706 | 7-682-567-09 | s | SCREW, +B 4X25 |
| | A-6032-066-B | o | PANEL (1) ASSY, REAR (for UC, EK) | 707 | 7-682-572-09 | s | SCREW, +B 4X50 |
| A06 | A-6032-069-A | o | PANEL ASSY, CN-A | 708 | 7-682-903-11 | s | SCREW, +PWH 3X6 |
| A07 | A-6032-070-A | o | PANEL ASSY, CN-B | 709 | 7-682-947-01 | s | SCREW, +PSW 3X6 |
| A08 | A-6032-081-A | o | PANEL (B) ASSY, RS-422 | 710 | 7-684-023-04 | s | N 3, TYPE 2 |
| A10 | A-6032-080-A | o | PANEL ASSY, PARALLEL I/O | 711 | 7-688-003-01 | s | W 3, SMALL |
| X01 | X-3715-349-1 | s | PLATE ASSY, SHIELD, SUB | 712 | 7-688-004-01 | s | W 4, SMALL |
| X02 | X-4854-207-0 | s | TERMINAL ASSY, GROUND | 713 | 7-688-004-12 | s | W 4, MIDDLE |
| 101 | 1-509-176-51 | s | RECEP, XLR 3P, MALE | 714 | 7-682-545-09 | s | SCREW, +B 3X4 |
| 102 | 1-509-184-51 | s | RECEP, XLR 3P, FEMALE | 715 | 7-688-003-12 | s | W3 |
| 103 | 1-514-524-00 | s | SWITCH, SLIDE | | | | |
| 104 | 1-541-437-11 | s | MOTOR, DC FAN | | | | |
| 105 | 1-561-781-21 | s | RECEP, BNC | | | | |
| 201 | 2-083-308-00 | s | SPRING | | | | |
| 202 | 2-369-812-11 | o | COVER, FUN | | | | |
| 203 | 2-387-010-01 | o | SPACER | | | | |
| 204 | 2-390-741-00 | o | BUSHING, RUBBER | | | | |
| 301 | 3-531-576-11 | o | RIVET | | | | |
| 302 | 3-576-921-00 | s | SPRING, COMPRESSION | | | | |
| 303 | 3-673-249-00 | o | LEVER, PC BOARD | | | | |
| 304 | 3-673-676-01 | o | RAIL, GUIDE, CHASSIS | | | | |
| 305 | 3-680-316-00 | s | NUT 4, STOPPER | | | | |
| 306 | 3-680-316-11 | o | NUT 4, STOPPER | | | | |
| 307 | 3-703-043-51 | s | LABEL, CAUTION, MAIN | | | | |
| 308 | 3-715-517-01 | o | HINGE, PARALLEL | | | | |
| 309 | 3-715-590-01 | o | LABEL, SERIAL NUMBER (RF-15) | | | | |
| | 3-715-590-11 | o | LABEL, SERIAL NUMBER (AE-05) | | | | |
| | 3-715-590-21 | o | LABEL, SERIAL NUMBER (CD-35) | | | | |
| | 3-715-590-31 | o | LABEL, SERIAL NUMBER (RS-23) | | | | |
| | 3-715-590-41 | o | LABEL, SERIAL NUMBER (SP-01) | | | | |
| | 3-715-590-61 | o | LABEL, SERIAL NUMBER (SY-124) | | | | |

POWER ASS'Y

POWER ASSEMBLY, DVR-1000

| No. | Part No. | SP | Description |
|-----|----------------|----|--------------------------|
| A01 | A-6023-039-A | o | COMPLETE PCB, PS-138 |
| A02 | A-6023-040-A | o | COMPLETE PCB, RE-32 |
| A03 | A-6023-041-A | o | COMPLETE PCB, CT-74 |
| A04 | A-6023-042-A | o | COMPLETE PCB, MD-43 |
| A05 | A-6023-043-A | o | COMPLETE PCB, PD-36 |
| A06 | A-6023-044-A | o | COMPLETE PCB, MB-137 |
| A07 | A-6026-071-A | o | COMPLETE PCB, FC-37 |
| A08 | A-6038-029-A | o | POWER ASSY |
| 101 | A-1-526-956-11 | s | INLET, AC (NOISE FILTER) |
| 102 | A-1-532-545-51 | s | BREAKER, CIRCUIT |
| 103 | A-1-554-011-00 | s | SWITCH, ROCKER |
| 301 | 3-531-576-11 | o | RIVET |
| 302 | 3-657-845-00 | o | BRACKET, PC BOARD |
| 303 | 3-701-699-00 | o | LABEL, GROUND TERMINAL |
| 304 | 3-715-524-02 | o | COVER |
| 305 | 3-715-525-02 | o | LABEL, POWER |
| 306 | 3-715-526-01 | o | WASHER 3 |
| 701 | 7-621-759-45 | s | SCREW, +PSW 2.6X6 |
| 702 | 7-623-423-07 | s | LW 4, TYPE B |
| 703 | 7-682-547-09 | s | SCREW, +B 3X6 |
| 704 | 7-682-549-09 | s | SCREW, +B 3X10 |
| 705 | 7-682-903-11 | s | SCREW, +PWH 3X6 |
| 706 | 7-682-947-01 | s | SCREW, +PSW 3X6 |
| 707 | 7-682-948-01 | s | SCREW, +PSW 3X8 |
| 708 | 7-682-961-01 | s | SCREW, +PSW 4X8 |

POWER ASS'Y POWER ASS' Y

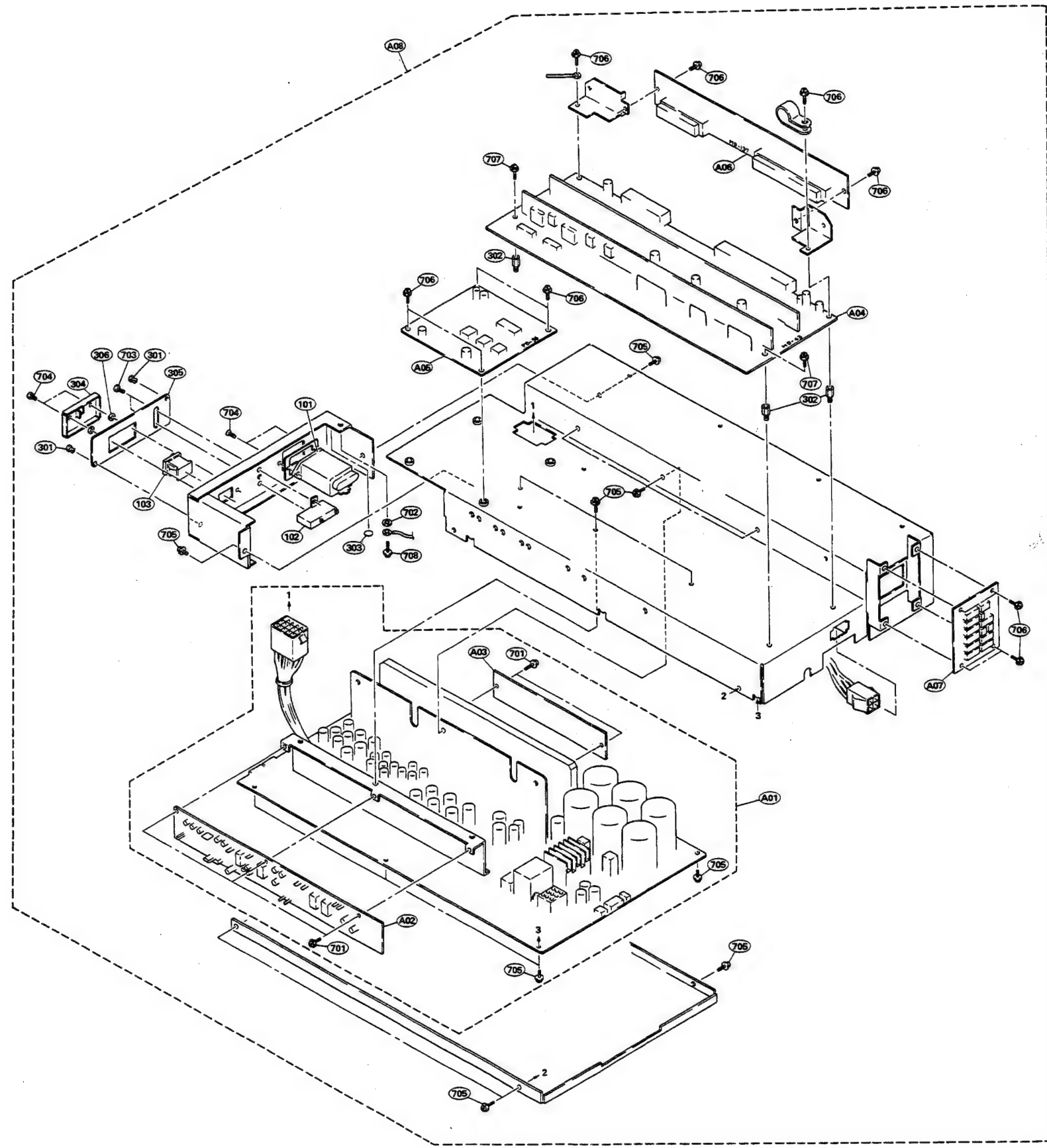

CASSETTE COMPARTMENT ASS'Y CASSETTE COMPARTMENT ASS'Y

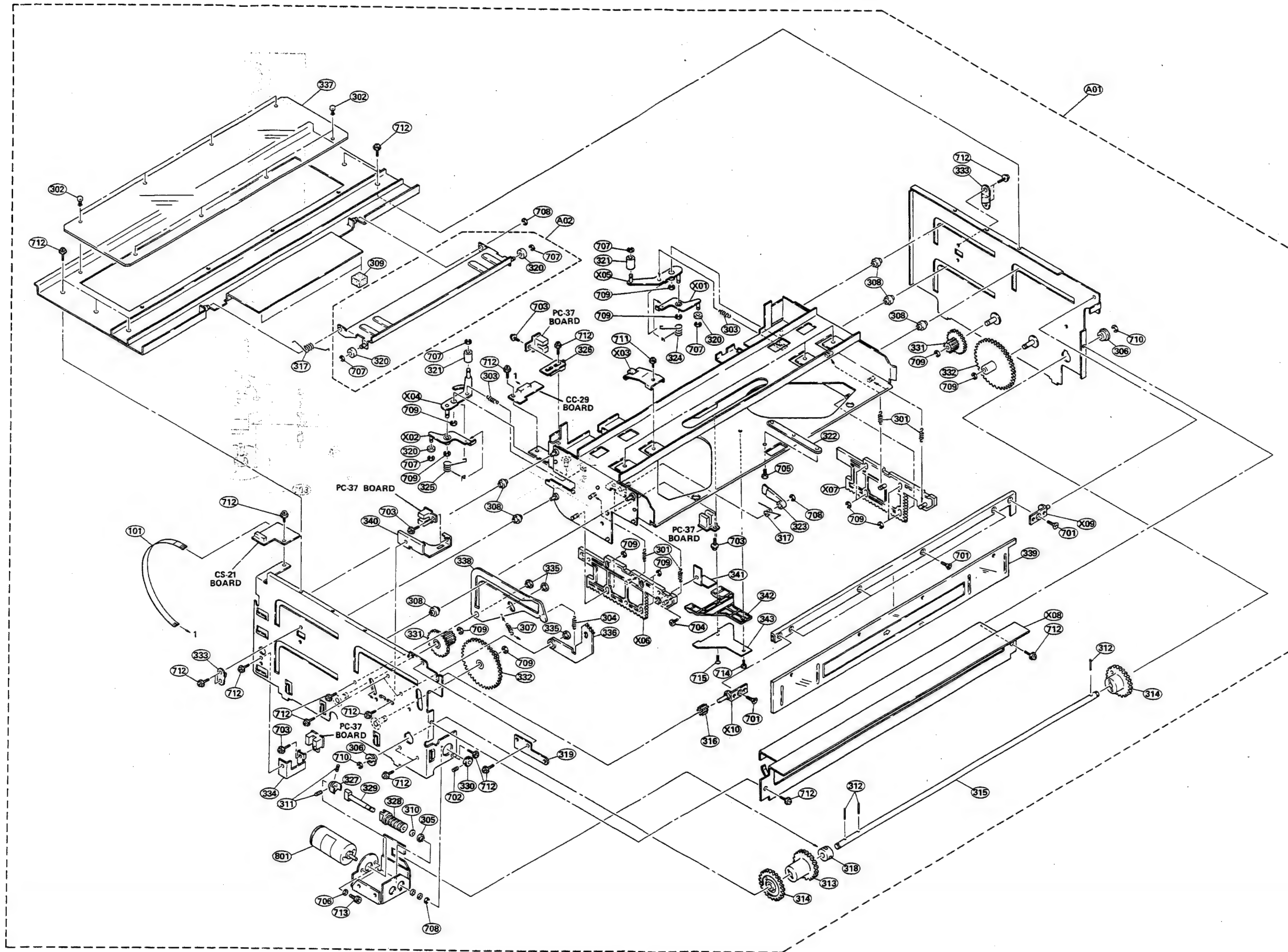

CASSETTE COMPARTMENT ASS'Y

CASSETTE COMPARTMENT ASSEMBLY, DVR-1000

(CASSETTE COMPARTMENT ASSEMBLY, DVR-1000)

| No. | part No. | SP | Description | No. | part No. | SP | Description |
|-----|--------------|----|--------------------------------|-----|--------------|----|-----------------------------|
| A01 | A-6028-008-A | s | CASSETTE COMPARTMENT COMP ASSY | 323 | 3-715-550-01 | o | SHUTTER, SENSOR |
| A02 | A-6028-007-A | o | PLATE ASSY, STOPPER | 324 | 3-715-551-01 | o | SPRING (RIGHT) |
| X01 | X-3715-333-1 | o | LEVER ASSY, PUSH-OUT, RIGHT | 325 | 3-715-552-01 | o | SPRING (LEFT) |
| X02 | X-3715-334-1 | o | LEVER ASSY, PUSH-OUT, LEFT | 326 | 3-715-553-01 | o | BRACKET, IN SW |
| X03 | X-3715-335-1 | o | ROLLER ASSY, STOPPER | 327 | 3-715-572-01 | o | RING, CUP |
| X04 | X-3715-336-1 | o | ARM (LEFT) ASSY, PUSH-OUT | 328 | 3-715-573-01 | s | GEAR, WORM |
| X05 | X-3715-337-1 | o | ARM (RIGHT) ASSY, PUSH-OUT | 329 | 3-715-574-01 | o | SHAFT, WORM GEAR |
| X06 | X-3715-338-3 | o | RACK (LEFT) ASSY | 330 | 3-715-575-01 | o | WHEEL, DRIVING |
| X07 | X-3715-339-3 | o | RACK (RIGHT) ASSY | 331 | 3-715-576-01 | s | GEAR (A) |
| X08 | X-3715-346-3 | o | PLATE (A) ASSY, FRONT | 332 | 3-715-577-01 | s | GEAR (B) |
| X09 | X-3715-390-1 | o | PLATE (RIGHT) ASSY, SHAFT | 333 | 3-715-578-01 | s | CAM, PUSH-OUT |
| X10 | X-3715-391-1 | o | PLATE (LEFT) ASSY, SHAFT | 334 | 3-715-579-01 | o | BRACKET, SENSOR, DOWN |
| 101 | 1-559-046-11 | s | WIRE, FLEXIBLE CARD 4P | 335 | 3-715-580-01 | o | SHAFT, LID OPEN CAM |
| 301 | 3-497-257-03 | s | SPRING, TENSION | 336 | 3-715-581-02 | o | ARM, LID SWITCHING |
| 302 | 3-531-576-11 | o | RIVET | 337 | 3-715-655-03 | o | COVER |
| 303 | 3-542-475-00 | s | SPRING, TENSION | 338 | 3-715-657-01 | o | CAM, LID OPEN |
| 304 | 3-563-103-00 | s | SPRING, TENSION | 339 | 3-715-658-03 | o | LID, CASSETTE COMPARTMENT |
| 305 | 3-642-569-00 | o | BEARING, DIA.3 | 340 | 3-715-888-02 | o | BRACKET, UP SENSOR |
| 306 | 3-642-595-03 | s | BEARING (6) | 341 | 3-715-894-01 | o | PLATE, SENSOR, UP |
| 307 | 3-643-344-00 | s | SPRING, TENSION | 342 | 3-716-773-01 | o | GUIDE, CASSETTE COMPARTMENT |
| 308 | 3-668-299-00 | s | ROLLER, GUIDE | 343 | 3-716-774-01 | o | RETAINER, GUIDE |
| 309 | 3-672-926-00 | o | CUSHION, LID | 701 | 7-621-592-10 | s | SCREW, +K 2.6X8 |
| 310 | 3-701-439-01 | s | WASHER | 702 | 7-621-733-08 | s | SET SCREW, FLAT POINT 2X4 |
| 311 | 3-701-505-00 | s | SET SCREW, DOUBLE POINT 3X3 | 703 | 7-621-759-35 | s | SCREW, +PSW 2.6X5 |
| 312 | 3-703-358-06 | s | PIN, PARALLEL (DIA. 2X14) | 704 | 7-621-772-20 | s | SCREW, +B 2X5 |
| 313 | 3-715-538-01 | s | WHEEL, WORM | 705 | 7-621-775-10 | s | SCREW, +B 2.6X4 |
| 314 | 3-715-539-01 | s | GEAR (C) | 706 | 7-623-208-22 | s | SW 3, TYPE 2 |
| 315 | 3-715-540-01 | o | SHAFT, DRIVING | 707 | 7-624-102-04 | s | STOP RING 1.5, TYPE-E |
| 316 | 3-715-541-01 | s | GEAR, LID | 708 | 7-624-105-04 | s | STOP RING 2.3, TYPE-E |
| 317 | 3-715-542-01 | o | SPRING | 709 | 7-624-106-04 | s | STOP RING 3.0, TYPE-E |
| 318 | 3-715-543-01 | s | COLLAR, JOINT SHAFT | 710 | 7-624-109-04 | s | STOP RING 5.0, TYPE-E |
| 319 | 3-715-545-01 | o | PLATE, FIXED, LID SHAFT | 711 | 7-682-903-01 | s | SCREW, +PWH 3X5 |
| 320 | 3-715-546-01 | o | ROLLER, PUSH-OUT | 712 | 7-682-903-11 | s | SCREW, +PWH 3X6 |
| 321 | 3-715-547-01 | s | ROLLER (2), PUSH-OUT | 713 | 7-683-402-04 | s | SCREW, C 3X5 |
| 322 | 3-715-549-01 | o | RAIL, GUIDE, CENTERING | 714 | 7-621-592-00 | s | SCREW, +B 2.6X6 |
| | | | | 715 | 7-621-773-95 | s | SCREW, +K 2.6X6 |
| | | | | 801 | 8-835-047-01 | s | MOTOR, DC (MNR-4000A) |

REEL TABLE ASS' Y

REEL TABLE ASSEMBLY, DVR-1000

| No. | Part No. | SP | Description |
|-----|--------------|----|--------------------------------|
| A01 | A-6029-005-A | o | TABEL ASSY, REEL |
| A02 | A-6029-014-B | o | PIN ASSY, UB |
| X01 | X-3715-301-1 | o | ROD ASSY, LIMITER |
| X02 | X-3715-302-1 | o | PLATE ASSY, BRAKE, S |
| X03 | X-3715-303-1 | o | PLATE ASSY, BRAKE, T |
| X04 | X-3715-304-1 | o | PULLEY (L) ASSY, TIMING |
| X05 | X-3715-305-1 | o | ARM ASSY, CRANK |
| X06 | X-3715-307-1 | o | FLAG ASSY, UB |
| X07 | X-3715-342-1 | o | BEARING ASSY, CRANK |
| X08 | X-3715-393-1 | s | ARM ASSY, BRAKE |
| X09 | X-3715-487-1 | o | SPRING ASSY (S) RETURN |
| X10 | X-3715-488-1 | o | SPRING ASSY (T) RETURN |
| 101 | 1-454-433-12 | s | SOLENOID, PLUNGER |
| 102 | 1-541-376-11 | s | MOTOR, DC (DNR-4700A) |
| 103 | 1-559-045-11 | s | WIRE, FLEXIBLE CARD 26P |
| 301 | 3-302-492-00 | s | SPRING, COMPRESSION |
| 302 | 3-554-091-00 | s | SPRING, TENSION |
| 303 | 3-642-629-00 | s | SPRING, COMPRESSION |
| 304 | 3-701-441-21 | s | WASHER |
| 305 | 3-701-443-21 | s | WASHER, 5 |
| 306 | 3-701-506-01 | s | SET SCREW, DOUBLE POINT 3X4 |
| 307 | 3-701-511-00 | s | SET SCREW, DOUBLE POINT 4X6 |
| 308 | 3-703-358-54 | o | PIN, PARALLEL (DIA. 2X10) |
| 309 | 3-715-313-01 | o | ARM (B), CRANK |
| 310 | 3-715-316-01 | o | SHAFT |
| 311 | 3-715-316-11 | o | SHAFT |
| 312 | 3-715-329-01 | o | SHAFT, CASSETTE HEIGHT |
| 313 | 3-715-331-01 | o | SLEEVE, LIMITER |
| 314 | 3-715-339-01 | s | SLEEVE |
| 315 | 3-715-340-01 | o | SPRING |
| 316 | 3-715-341-01 | o | CLAW, REEL TABLE |
| 317 | 3-715-347-01 | o | SHAFT (A), CRANK |
| 318 | 3-715-348-02 | s | WHEEL, W |
| 319 | 3-715-348-12 | s | WHEEL, W |
| 320 | 3-715-350-01 | o | PULLEY (S), TIMING |
| 321 | 3-715-351-01 | o | BEARING (B) |
| 322 | 3-715-352-01 | o | SHAFT, WORM |
| 323 | 3-715-354-01 | s | WORM |
| 324 | 3-715-354-11 | s | WORM |
| 325 | 3-715-356-01 | s | GEAR (A), FLAT |
| 326 | 3-715-357-01 | s | GEAR (B), FLAT |
| 327 | 3-715-359-01 | o | BELT, TIMING |

(REEL TABLE ASSEMBLY, DVR-1000)

| No. | Part No. | SP | Description |
|-----|--------------|----|------------------------------|
| 328 | 3-715-614-04 | o | FRAME (S), MOTOR |
| 329 | 3-715-615-04 | o | FRAME (T), MOTOR |
| 330 | 3-715-358-52 | o | PIN, PARALLEL (DIA. 2X6) |
| 331 | 3-701-438-01 | o | WASHR 2.5, t=0.13 |
| 401 | 4-879-763-00 | s | SPRING, COMPRESSION |
| 701 | 7-621-759-35 | s | SCREW, +PSW, 2.6X5 |
| 702 | 7-621-772-30 | s | SCREW, +B 2X6 |
| 703 | 7-623-208-22 | s | SW 3, TYPE 2 |
| 704 | 7-624-102-04 | s | STOP RING 1.5, TYPE-E |
| 705 | 7-624-105-04 | s | STOP RING 2.3, TYPE-E |
| 706 | 7-624-106-04 | s | STOP RING 3.0, TYPE-E |
| 707 | 7-624-108-04 | s | STOP RING 4.0, TYPE-E |
| 708 | 7-624-197-11 | s | STOP RING 14, TYPE-C |
| 709 | 7-627-454-17 | s | SCREW, +K 2.6X4 |
| 710 | 7-628-254-00 | s | SCREW, +PS 2.6X5 |
| 711 | 7-682-647-09 | s | SCREW, +PS 3X6 |
| 712 | 7-682-947-01 | s | SCREW, +PSW 3X6 |
| 713 | 7-682-948-01 | s | SCREW, +PSW 3X8 |
| 714 | 3-724-831-01 | s | SET SCREW, FLAT POINT 3X4 |
| 715 | 7-683-402-04 | s | SCREW, C 3X5 |
| 716 | 7-683-410-04 | s | SCREW, C 3X20 |
| 718 | 7-685-132-29 | s | SCREW, P 2.6X5 |
| 719 | 7-621-775-10 | o | SCREW, +B 2.6X4 |
| 801 | 8-835-227-01 | s | MOTOR, DC U-6A |

REEL TABLE ASS'Y REEL TABLE ASS'Y

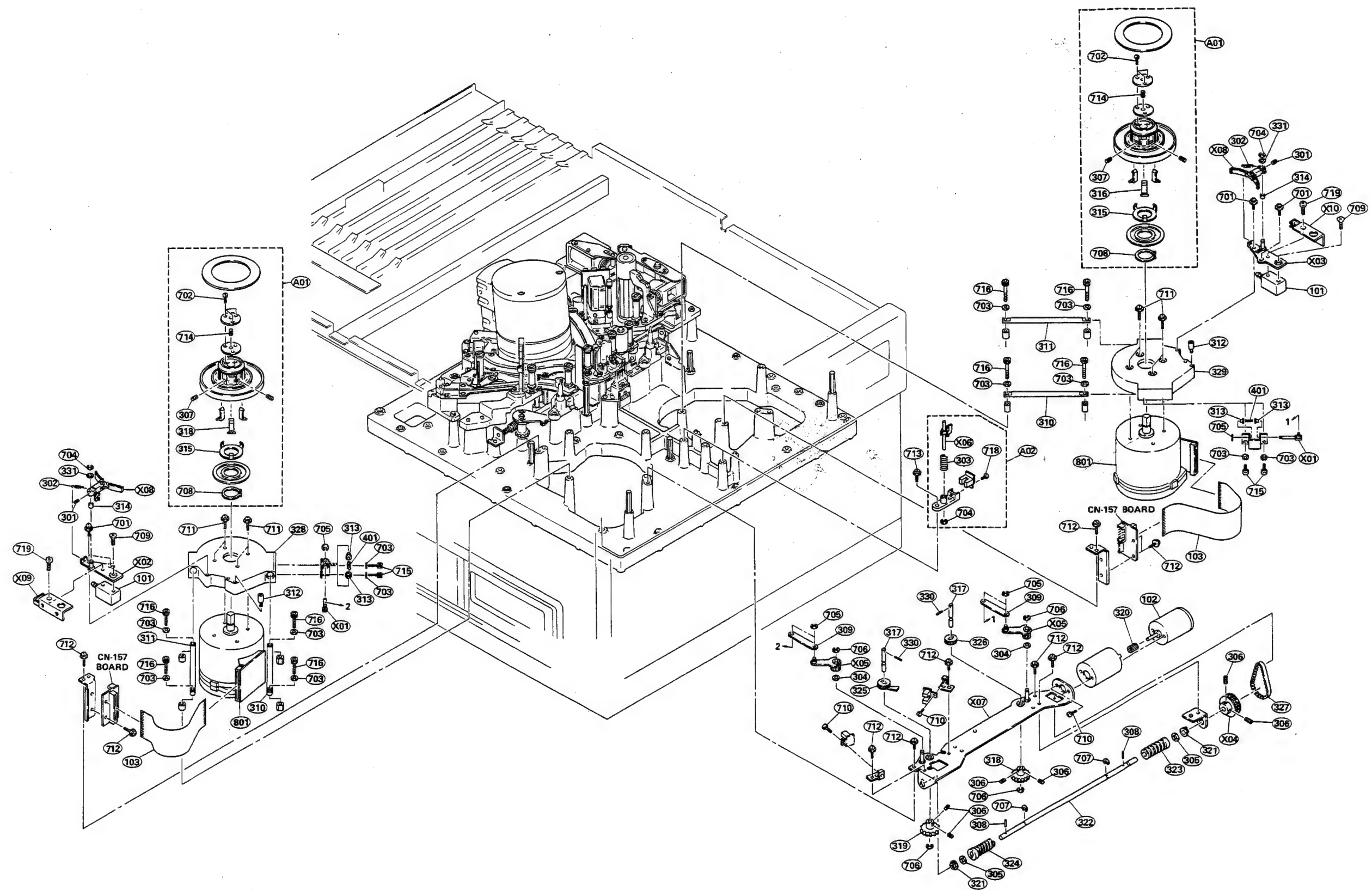

S SIDE GUIDES & PINCH ROLLER ASS'Y

S SIDE GUIDES & PINCH ROLLER ASSEMBLY, DVR-1000

| No. | part No. | SP | Description |
|-----|--------------|----|-----------------------------------|
| A01 | A-6029-045-B | s | GUIDE ASSY, S DRAWER |
| A02 | A-6029-017-A | o | SENSOR ASSY, END |
| A03 | A-6029-029-A | o | HOLDER ASSY, TENSION REGULATOR |
| A04 | A-6029-043-B | s | PINCH ASSY |
| X01 | X-3715-315-2 | o | ARM ASSY |
| X02 | X-3715-317-1 | o | LINK ASSY, RETURN |
| X03 | X-3715-318-1 | o | LINK ASSY, ROTARY |
| X04 | X-3715-319-1 | o | LINK (S) ASSY, ROTARY |
| X05 | X-3715-320-1 | o | ARM ASSY, SS |
| X06 | X-3715-323-1 | s | ARM (B) ASSY, TENSION |
| X07 | X-3715-324-1 | s | SHAFT ASSY, TENSION REGULATOR |
| X08 | X-3715-325-4 | o | SLIDER ASSY, S DRAWER |
| X09 | X-3715-326-1 | o | GUIDE BLOCK ASSY, S |
| X10 | X-3715-375-1 | s | GUIDE (N) ASSY, ROLLER |
| X11 | X-3715-377-1 | o | GUIDE (SUB) ASSY, ROLLER |
| X12 | X-3715-388-2 | o | SUPPORT ASSY, PINCH |
| X13 | X-3715-389-2 | o | PINCH BLOCK ASSY |
| X14 | X-3715-397-1 | s | GUIDE BLOCK ASSY, S DRAWER |
| X15 | X-3715-489-1 | o | RETAINER ASSY, GUIDE, PS |
| X16 | X-3715-376-1 | s | GUIDE (W) ASSY, ROLLER |
| 301 | 3-161-605-01 | s | BEARING (FLANGE), BALL |
| 302 | 3-305-526-00 | s | SPRING, TENSION |
| 303 | 3-458-053-01 | s | SPRING, COMPRESSION |
| 304 | 3-570-228-00 | s | SPRING, COMPRESSION |
| 305 | 3-575-488-00 | s | SPRING, COMPRESSION |
| 306 | 3-646-114-00 | o | PIN, SPRING |
| 307 | 3-651-607-00 | s | BEARING, BALL |
| 308 | 3-659-338-00 | s | SPRING, COMPRESSION |
| 309 | 3-672-461-00 | s | SPRING, TENSION |
| 310 | 3-673-761-01 | o | PIECE, ADJUSTMENT |
| 311 | 3-701-439-01 | s | WASHER 3, t=0.13 |
| | 3-701-439-11 | s | WASHER 3, t=0.25 |
| 312 | 3-701-441-01 | s | WASHER |
| 313 | 3-701-441-11 | s | WASHER |
| 314 | 3-701-441-21 | s | WASHER |
| 315 | 3-701-443-21 | s | WASHER, 5 |
| 316 | 3-701-505-00 | s | SET SCREW, DOUBLE POINT 3X4 |
| 317 | 3-715-410-01 | o | LINK, ROAD |
| 318 | 3-715-411-01 | o | SPRING |
| 319 | 3-715-422-01 | s | WHEEL, LINK |
| 320 | 3-715-423-01 | o | NUT, LINK |
| 321 | 3-715-426-01 | s | WHEEL (S), LINK |

(S SIDE GUIDES & PINCH ROLLER ASSEMBLY, DVR-1000)

| No. | part No. | SP | Description |
|-----|--------------|----|------------------------------|
| 322 | 3-715-447-01 | o | RETAINER (A), BEARING |
| 323 | 3-715-448-01 | o | HOLDER, DME |
| 324 | 3-715-449-01 | o | RETAINER, BEARING |
| 326 | 3-715-613-01 | s | RAIL, SS |
| 327 | 3-724-810-01 | s | SPACER, D |
| 328 | 3-715-812-01 | s | FLANGE |
| 329 | 3-715-813-01 | s | RETAINER, FLANGE |
| 330 | 3-715-814-01 | s | HOLDER (2), COLOR |
| 331 | 3-716-725-01 | o | RETAINER BLOCK (SS) |
| 332 | 3-716-775-02 | s | FLANGE, (B) |
| 333 | 3-716-776-02 | o | STOPPR ROTATION |
| 334 | 3-701-577-00 | s | SCREW (M2X5), CAP |
| 401 | 4-866-079-01 | s | SPRING, COMPRESSION |
| 701 | 7-621-759-45 | s | SCREW, +PSW 2.6X6 |
| 702 | 7-621-772-10 | s | SCREW, +B 2X4 |
| 703 | 7-621-775-10 | s | SCREW, +B 2.6X4 |
| 704 | 7-624-102-04 | s | STOP RING 1.5, TYPE-E |
| 705 | 7-624-105-04 | s | STOP RING 2.3, TYPE-E |
| 706 | 7-624-106-04 | s | STOP RING 3.0, TYPE-E |
| 707 | 7-624-132-11 | s | STOP RING 10, TYPE-C |
| 708 | 7-626-305-61 | o | SPRING PIN 1X4 |
| 709 | 7-627-553-68 | s | SCREW, PRECISION +P 2X6 |
| 710 | 7-627-556-38 | s | SCREW, +P 2.6X4.0 |
| 711 | 7-628-253-00 | s | SCREW, +PS 2X4 |
| 712 | 7-628-254-30 | s | SCREW, +PS 2.6X10 |
| 713 | 7-682-948-01 | s | SCREW, +PSW 3X8 |
| 714 | 7-682-950-01 | s | SCREW, +PSW 3X12 |
| 715 | 7-683-237-01 | s | SET SCREW, FLAT POINT 3X3 |
| 716 | 7-683-404-04 | s | SCREW, C 3X8 |
| 717 | 7-685-103-19 | s | SCREW, +P 2X5 TYPE2 SLIT |
| 718 | 7-688-002-01 | s | W 2.6, SMALL |
| 719 | 7-688-003-01 | s | W 3, SMALL |
| 720 | 7-623-924-11 | s | WASHR 3, t=0.8 |
| 801 | 8-825-770-01 | s | HEAD, FE |

T SIDE GUIDES & CAPSTAN ASS' Y

T SIDE GUIDES & CAPSTAN ASSEMBLY, DVR-1000

| No. | Part No. | SP | Description |
|-----|--------------|----|-----------------------------|
| A01 | A-6029-050-A | o | BASE ASSY, T GUIDE |
| A02 | A-6029-012-D | o | CD BLOCK ASSY |
| A03 | A-6029-013-B | o | PIN ASSY, STANDARD |
| A04 | A-6029-017-A | o | SENSOR ASSY, END |
| X01 | X-3715-309-1 | o | PIN ASSY, LINK |
| X02 | X-3715-310-1 | o | BASE ASSY, T ROLLER |
| X03 | X-3715-311-1 | o | ARM ASSY, PRESS |
| X04 | X-3715-375-1 | s | GUIDE (N) ASSY, ROLLER |
| X05 | X-3715-313-2 | o | BASE ASSY, SLIDE |
| X06 | X-3715-312-2 | o | BASE ASSY, AU |
| 101 | 1-454-434-11 | s | SOLENOID, PLUNGER |
| 201 | 2-266-943-00 | s | SPRING, COMPRESSION |
| 301 | 3-429-123-00 | s | SPRING |
| 302 | 3-498-078-01 | o | SPRING, COMPRESSION |
| 303 | 3-554-017-00 | s | SPRING, COMPRESSION |
| 304 | 3-673-907-00 | o | SCREW (M3) |
| 305 | 3-680-316-00 | s | NUT (M4), STOPPER |
| 306 | 3-701-439-01 | s | WASHER 3, t=0.13 |
| 307 | 3-701-439-11 | s | WASHER 3, t=0.25 |
| 308 | 3-701-439-21 | s | WASHER 3, t=0.50 |
| 309 | 3-701-444-11 | s | WASHER 6, t=0.25 |
| 310 | 3-701-444-21 | s | WASHER 6, t=0.50 |
| 311 | 3-701-447-21 | s | WASHER 10 |
| 312 | 3-701-506-01 | s | SET SCREW, DOUBLE POINT 3X4 |
| 313 | 3-715-319-01 | s | SPACER (K), t=10um |
| | 3-715-319-11 | s | SPACER (K), t=20um |
| 314 | 3-715-374-02 | o | LINK, SUB |
| 315 | 3-715-375-01 | o | SUPPORT, SUB LINK |
| 316 | 3-715-376-01 | o | STOPPER, ARM |
| 317 | 3-715-377-01 | o | STOPPER, AU |
| 318 | 3-715-379-01 | o | SHAFT, ARM, PRESS |
| 319 | 3-715-380-01 | o | SPACER, ROTARY |
| 320 | 3-715-385-01 | o | LIMITER, PRESS |
| 321 | 3-715-386-01 | o | LINK, LIMITTER |
| 322 | 3-715-387-01 | o | PIN, PRESS |
| 323 | 3-715-388-01 | o | PRESS BLOCK |
| 324 | 3-715-389-01 | o | PLATE, PRESS, PINCH |
| 325 | 3-715-390-01 | o | PLATE, ADJUSTMENT, ARM |
| 326 | 3-715-391-01 | o | SPRING |
| 327 | 3-715-395-02 | o | PLATE, POSITIONING |
| 328 | 3-715-396-02 | o | LINK, SOLENOID |
| 329 | 3-715-398-01 | o | PIN, SOLENOID |
| 330 | 3-715-401-01 | o | PIN, AU LOCK |
| 331 | 3-715-402-01 | o | FLANGE, FIXED |
| 332 | 3-715-403-01 | o | GUIDE, F FIXED |
| 333 | 3-715-404-01 | o | RETAINER, GUIDE |

(T SIDE GUIDES & CAPSTAN ASSEMBLY, DVR-1000)

| No. | Part No. | SP | Description |
|-----|--------------|----|---------------------------|
| 334 | 3-715-809-11 | s | SPACER (R) |
| 335 | 3-715-812-02 | s | FLANGE |
| 336 | 3-715-813-01 | s | RETAINER, FLANGE |
| 337 | 3-715-814-11 | s | HOLDER (2), COLOR |
| 401 | 4-866-079-01 | s | SPRING, COMPRESSION |
| 402 | 4-887-106-00 | s | SPRING, COMPRESSION |
| 701 | 7-623-208-22 | s | SW 3, TYPE 2 |
| 702 | 7-624-105-04 | s | STOP RING 2.3, TYPE-E |
| 703 | 7-624-109-04 | s | STOP RING 5.0, TYPE-E |
| 704 | 7-627-553-38 | s | SCREW, PRECISION +P 2X3 |
| 705 | 7-627-556-38 | s | SCREW, +P 2.6X4.0 |
| 706 | 7-628-254-15 | s | SCREW, PS 2.6X6 |
| 707 | 7-682-649-09 | s | SCREW, +PS 3X10 |
| 708 | 7-682-664-09 | s | SCREW, +PS 4X14 |
| 709 | 7-682-903-11 | s | SCREW, +PWH 3X6 |
| 710 | 7-682-947-01 | s | SCREW, +PSW 3X6 |
| 711 | 7-682-948-01 | s | SCREW, +PSW 3X8 |
| 712 | 7-682-949-01 | s | SCREW, +PSW 3X10 |
| 713 | 7-682-950-01 | s | SCREW, +PSW 3X12 |
| 714 | 7-683-237-01 | s | SET SCREW, FLAT POINT 3X3 |
| 715 | 7-683-404-04 | s | SCREW, C 3X8 |
| 716 | 7-683-406-04 | s | SCREW, C 3X12 |
| 717 | 7-683-408-04 | s | SCREW, C 3X16 |
| 718 | 7-685-103-19 | s | SCREW, +P 2X5, TYPE2 SLIT |
| 719 | 7-688-001-01 | s | W 2, SMALL |
| 720 | 7-688-001-12 | s | W 2, MIDDLE |
| 721 | 7-688-002-01 | s | W 2.6, SMALL |
| 722 | 7-688-003-01 | s | W 3, SMALL |
| 723 | 7-688-004-01 | s | W 4, SMALL |
| 801 | 8-825-770-12 | s | HEAD, AUDIO |
| 802 | 8-835-234-01 | s | MOTOR, DC BHF-1916A |

SLANT GUIDE, THREADING MOTOR & DRIVING SHAFT ASS'Y

SLANT GUIDE, THREADING MOTOR & DRIVING SHAFT ASSEMBLY, DVR-1000

(SLANT GUIDE, THREADING MOTOR & DRIVING SHAFT ASSEMBLY, DVR-1000)

| No. | Part No. | SP | Description | No. | Part No. | SP | Description |
|-----|--------------|----|-----------------------------|-----|--------------|----|----------------------------|
| A01 | A-6029-046-A | s | GUIDE ASSY, S SLANT | 330 | 3-715-488-01 | o | SLEEVE, WORM GEAR |
| A02 | A-6029-047-A | s | GUIDE ASSY, S ROLLER | 331 | 3-715-489-01 | o | SHAFT, GB WORM |
| A03 | A-6029-048-B | s | GUIDE ASSY, T SLANT | 332 | 3-715-490-01 | s | WORM (G) |
| A04 | A-6029-042-C | o | GUIDE ASSY, T ROLLER | 333 | 3-715-491-01 | o | JOINT, SHAFT |
| A05 | A-6029-037-A | o | BOX ASSY, GEAR | 334 | 3-715-494-01 | o | SCREW, LOADING |
| X01 | X-3715-321-1 | o | BRACKET ASSY, GEAR | 335 | 3-715-495-01 | s | GUIDE, FIXED |
| X02 | X-3715-329-2 | o | SLIDER ASSY, S SLANT GUIDE | 336 | 3-715-628-01 | o | HOLDER, S FIXED GUIDE |
| X03 | X-3715-330-1 | o | SLIDER ASSY, T SLANT GUIDE | 337 | 3-715-630-01 | o | HOLDER, T FIXED GUIDE |
| X04 | X-3715-377-1 | o | GUIDE SUB ASSY, ROLLER | 338 | 3-715-803-01 | s | FLANGE (2), ROLLER (LOWER) |
| 101 | 1-237-578-11 | s | POTENTIOMETER 5K | 339 | 3-715-812-01 | s | FLANGE |
| 201 | 2-640-047-01 | s | SCREW 2X5 | 340 | 3-715-813-01 | s | RETAINER, FLANGE |
| 301 | 3-481-272-00 | s | SPRING, COMPRESSION | 341 | 3-715-814-01 | s | HOLDER (2), COLOR |
| 302 | 3-572-513-00 | o | SPRING, COMPRESSION | 342 | 3-715-874-01 | s | BEARING (FLANGE), BALL |
| 303 | 3-659-338-00 | s | SPRING, COMPRESSION | 343 | 3-576-336-00 | s | SPRING, COMPRESSION |
| 304 | 3-692-591-01 | s | SCREW, +P 2X3, PRECISION | 344 | 3-722-964-01 | s | GUIDE, SLIDER |
| 305 | 3-701-439-11 | s | WASHER | 345 | 3-735-144-01 | o | COVER, GEAR BOX |
| 306 | 3-701-443-21 | s | WASHER 5 | 401 | 4-858-559-00 | s | WASHER |
| 307 | 3-701-505-00 | s | SET SCREW, DOUBLE POINT 3X3 | 402 | 4-866-079-01 | s | SPRING, COMPRESSION |
| 308 | 3-701-579-01 | o | SCREW M2X8, CAP | 701 | 7-621-772-10 | s | SCREW, +B 2X4 |
| 309 | 3-715-319-01 | s | SPACER (K), t=10um | 702 | 7-624-105-04 | s | STOP RING 2.3, TYPE-E |
| | 3-715-319-11 | s | SPACER (K), t=20um | 703 | 7-624-108-04 | s | STOP RING 4.0, TYPE-E |
| | 3-715-319-21 | s | SPACER (K), t=30um | 704 | 7-682-646-09 | s | SCREW, +PS 3X5 |
| | 3-715-319-31 | s | SPACER (K), t=50um | 705 | 7-682-948-01 | s | SCREW, +PSW 3X8 |
| 310 | 3-715-325-01 | s | RAIL, S | 706 | 7-682-950-01 | s | SCREW, +PSW 3X12 |
| 311 | 3-715-326-01 | s | RAIL, T | 707 | 7-683-237-01 | s | SET SCREW, FLAT POINT 3X3 |
| 312 | 3-715-430-01 | o | SHAFT (C4), MAIN | 708 | 7-688-001-01 | s | W 2, SMALL |
| 313 | 3-715-431-01 | o | SPACER | 801 | 8-835-123-01 | s | MOTOR, DC (MNR-7400A) |
| 314 | 3-715-432-01 | o | SLEEVE, SLIDE | | | | |
| 315 | 3-715-433-01 | o | PIN, WORM | | | | |
| 316 | 3-715-434-01 | s | GEAR (I) | | | | |
| 317 | 3-715-435-01 | s | GEAR (T), WORM | | | | |
| 318 | 3-715-436-01 | s | GEAR (S), WORM | | | | |
| 319 | 3-715-437-01 | o | SLEEVE, B | | | | |
| 320 | 3-715-439-03 | s | GEAR (H) | | | | |
| 321 | 3-715-440-01 | s | GEAR (G) | | | | |
| 322 | 3-715-459-01 | o | SLIDER | | | | |
| 323 | 3-715-476-01 | s | GEAR (C) | | | | |
| 324 | 3-715-477-01 | s | GEAR (D) | | | | |
| 325 | 3-715-479-01 | s | GEAR (A) | | | | |
| 326 | 3-715-480-01 | o | GEAR (B) | | | | |
| 327 | 3-715-481-01 | o | SLEEVE, GB | | | | |
| 328 | 3-715-481-11 | o | SLEEVE, GB | | | | |
| 329 | 3-715-485-01 | s | GEAR (E) | | | | |

HEAD DRUM ASS' Y

HEAD DRUM ASSEMBLY, DVR-1000

| No. | Part No. | SP | Description |
|-----|--------------|----|-------------------------------|
| A01 | A-6050-470-B | s | HEAD DRUM ASSY, DDH-01A-R |
| A02 | A-6050-465-A | s | BUSHING ASSY, SHAFT GROUND |
| A03 | A-6050-471-B | s | SCANNER ASSY |
| X01 | X-3715-327-1 | o | BRACKET ASSY, DRUM |
| X02 | X-3715-371-1 | o | TABLE ASSY, SLANT |
| 201 | 2-623-773-21 | o | BOLT (M3X10), STAINLESS |
| 301 | 3-306-861-00 | s | SPRING, TENSION |
| 302 | 3-715-465-01 | o | GUIDE, GEAR |
| 303 | 3-715-468-01 | s | GEAR (F) |
| 304 | 3-715-470-01 | s | SPACER (ST), t=100um |
| | 3-715-470-11 | s | SPACER (ST), t=50um |
| | 3-715-470-21 | s | SPACER (ST), t=20um |
| | 3-715-470-31 | s | SPACER (ST), t=10um |
| 305 | 3-715-471-01 | o | GEAR, LOADING |
| 306 | 3-715-472-01 | o | LINK (S), BANANA |
| 307 | 3-715-473-01 | o | HOOK, SPRING |
| 308 | 3-715-474-01 | o | PIN (M), ARM |
| 309 | 3-715-475-01 | o | LINK (T), BANANA |
| 310 | 3-715-677-01 | o | RAIL BLOCK (S) |
| 311 | 3-715-678-01 | o | RAIL BLOCK (T) |
| 312 | 3-716-722-01 | o | SPACER, RAIL BLOCK, t=10um |
| | 3-716-722-11 | o | SPACER, RAIL BLOCK, t=20um |
| | 3-716-722-21 | o | SPACER, RAIL BLOCK, t=30um |
| 313 | 3-716-723-01 | o | RETAINER BLOCK (S) |
| 314 | 3-716-724-01 | o | RETAINER BLOCK (T) |
| 701 | 7-621-770-67 | s | SCREW, +B 2.6X6 |
| 702 | 7-621-772-10 | s | SCREW, +B 2X4 |
| 703 | 7-621-775-10 | s | SCREW, +B 2.6X4 |
| 704 | 7-623-208-22 | s | SW 3, TYPE 2 |
| 705 | 7-623-210-22 | s | SW 4, TYPE 2 |
| 706 | 7-624-106-04 | s | STOP RING 3.0, TYPE-E |
| 707 | 7-628-254-10 | s | SCREW, +PS 2.6X6 |
| 708 | 7-682-548-09 | s | SCREW, +B 3X8 |
| 709 | 7-682-948-01 | s | SCREW, +PSW 3X8 |
| 710 | 7-683-406-04 | s | SCREW, C 3X12 |
| 711 | 7-683-421-04 | s | SCREW, C 4X12 |
| 712 | 7-688-002-02 | s | W 2.6, SMALL |
| 713 | 7-688-003-01 | s | W 3, SMALL |
| 714 | 7-688-003-11 | s | W 3, MIDDLE |
| 715 | 7-688-004-01 | s | W 4, SMALL |

NONPOLAR CAPACITOR

Replacements for nonpolar capacitors not given in board parts lists are shown in the following list. If a capacitor with the desired working voltage is not found, choose one of a higher work

| Part No. | SP | Description | |
|--------------|----|--------------|----------------------|
| 1-107-019-00 | s | CAP, MICA | 1.0 pF ±0.5 pF 500 V |
| 1-107-039-00 | s | CAP, MICA | 1.2 pF ±0.5 pF 500 V |
| 1-107-040-00 | s | CAP, MICA | 1.5 pF ±0.5 pF 500 V |
| 1-107-041-00 | s | CAP, MICA | 1.8 pF ±0.5 pF 500 V |
| 1-107-042-00 | s | CAP, MICA | 2.2 pF ±0.5 pF 500 V |
| 1-107-043-00 | s | CAP, MICA | 2.7 pF ±0.5 pF 500 V |
| 1-107-044-00 | s | CAP, MICA | 3.3 pF ±0.5 pF 500 V |
| 1-107-045-00 | s | CAP, MICA | 3.9 pF ±0.5 pF 500 V |
| 1-107-046-00 | s | CAP, MICA | 4.7 pF ±0.5 pF 500 V |
| 1-107-026-00 | s | CAP, MICA | 5.1 pF ±0.5 pF 500 V |
| 1-107-047-00 | s | CAP, MICA | 5.6 pF ±0.5 pF 500 V |
| 1-107-048-00 | s | CAP, MICA | 6.8 pF ±0.5 pF 500 V |
| 1-107-049-00 | s | CAP, MICA | 8.2 pF ±0.5 pF 500 V |
| 1-107-202-00 | s | CAP, MICA | 10 pF 5% 500 V |
| 1-107-203-00 | s | CAP, MICA | 11 pF 5% 500 V |
| 1-107-204-00 | s | CAP, MICA | 12 pF 5% 500 V |
| 1-107-205-00 | s | CAP, MICA | 13 pF 5% 500 V |
| 1-107-206-00 | s | CAP, MICA | 15 pF 5% 500 V |
| 1-107-207-00 | s | CAP, MICA | 16 pF 5% 500 V |
| 1-107-208-00 | s | CAP, MICA | 18 pF 5% 500 V |
| 1-107-209-00 | s | CAP, MICA | 20 pF 5% 500 V |
| 1-107-210-00 | s | CAP, MICA | 22 pF 5% 500 V |
| 1-107-211-00 | s | CAP, MICA | 24 pF 5% 500 V |
| 1-107-157-00 | s | CAP, MICA | 27 pF 5% 500 V |
| 1-107-158-00 | s | CAP, MICA | 30 pF 5% 500 V |
| 1-107-159-00 | s | CAP, MICA | 33 pF 5% 500 V |
| 1-107-074-00 | s | CAP, MICA | 36 pF 5% 50 V |
| 1-107-075-00 | s | CAP, MICA | 39 pF 5% 50 V |
| 1-107-076-00 | s | CAP, MICA | 43 pF 5% 50 V |
| 1-107-077-00 | s | CAP, MICA | 47 pF 5% 50 V |
| 1-107-164-00 | s | CAP, MICA | 51 pF 5% 500 V |
| 1-107-165-00 | s | CAP, MICA | 56 pF 5% 500 V |
| 1-107-166-00 | s | CAP, MICA | 62 pF 5% 500 V |
| 1-107-036-00 | s | CAP, MICA | 68 pF 5% 500 V |
| 1-107-167-00 | s | CAP, MICA | 75 pF 5% 500 V |
| 1-107-083-00 | s | CAP, MICA | 82 pF 5% 50 V |
| 1-107-084-00 | s | CAP, MICA | 91 pF 5% 50 V |
| 1-107-085-00 | s | CAP, MICA | 100 pF 5% 50 V |
| 1-107-086-00 | s | CAP, MICA | 110 pF 5% 50 V |
| 1-107-087-00 | s | CAP, MICA | 120 pF 5% 50 V |
| 1-109-538-00 | s | CAP, MICA | 130 pF 5% 100 V |
| 1-109-539-00 | s | CAP, MICA | 150 pF 5% 100 V |
| 1-107-090-00 | s | CAP, MICA | 160 pF 5% 50 V |
| 1-109-540-00 | s | CAP, MICA | 180 pF 5% 100 V |
| 1-109-541-00 | s | CAP, MICA | 200 pF 5% 100 V |
| 1-109-542-00 | s | CAP, MICA | 220 pF 5% 100 V |
| 1-109-545-00 | s | CAP, MICA | 270 pF 5% 100 V |
| 1-109-547-00 | s | CAP, MICA | 330 pF 5% 100 V |
| 1-109-549-00 | s | CAP, MICA | 390 pF 5% 100 V |
| 1-109-633-00 | s | CAP, MICA | 470 pF 2% 500 V |
| 1-109-555-00 | s | CAP, MICA | 560 pF 5% 100 V |
| 1-109-635-00 | s | CAP, MICA | 680 pF 2% 500 V |
| 1-162-765-11 | s | CAP, CERAMIC | 0.001 5% 50 V |
| 1-162-769-11 | s | CAP, CERAMIC | 0.0022 5% 50 V |
| 1-162-777-11 | s | CAP, CERAMIC | 0.01 5% 50 V |
| 1-162-781-11 | s | CAP, CERAMIC | 0.022 5% 50 V |
| 1-162-806-11 | s | CAP, CERAMIC | 0.1 10% 50 V |
| 1-162-810-11 | s | CAP, CERAMIC | 0.22 10% 50 V |
| 1-162-812-11 | s | CAP, CERAMIC | 0.33 10% 50 V |

ELECTROLYTIC CAPACITOR

Replacements for electrolytic capacitors not given in board parts lists are shown in the following list. If a capacitor with the desired working voltage is not found, choose one of a higher working voltage.

| Part No. | SP | Description | |
|--------------|----|-------------|---------------|
| 1-124-902-00 | s | CAP, ELECT | 0.47 20% 50 V |
| 1-124-791-11 | s | CAP, ELECT | 1.0 20% 100 V |
| 1-124-925-11 | s | CAP, ELECT | 2.2 20% 100 V |
| 1-123-382-00 | s | CAP, ELECT | 3.3 20% 100 V |
| 1-124-927-00 | s | CAP, ELECT | 4.7 20% 100 V |
| 1-123-875-91 | s | CAP, ELECT | 10 20% 50 V |
| 1-124-908-11 | s | CAP, ELECT | 22 20% 50 V |
| 1-124-963-11 | s | CAP, ELECT | 33 20% 16 V |
| 1-124-482-11 | s | CAP, ELECT | 33 20% 35 V |
| 1-124-917-11 | s | CAP, ELECT | 33 20% 63 V |
| 1-124-446-11 | s | CAP, ELECT | 47 20% 10 V |
| 1-124-477-11 | s | CAP, ELECT | 47 20% 25 V |
| 1-124-910-11 | s | CAP, ELECT | 47 20% 50 V |
| 1-124-443-00 | s | CAP, ELECT | 100 20% 10 V |
| 1-126-101-11 | s | CAP, ELECT | 100 20% 16 V |
| 1-124-478-11 | s | CAP, ELECT | 100 20% 25 V |
| 1-124-122-11 | s | CAP, ELECT | 100 20% 50 V |
| 1-124-444-00 | s | CAP, ELECT | 220 20% 10 V |
| 1-124-120-11 | s | CAP, ELECT | 220 20% 25 V |
| 1-124-484-11 | s | CAP, ELECT | 220 20% 35 V |
| 1-124-911-11 | s | CAP, ELECT | 220 20% 50 V |
| 1-124-442-00 | s | CAP, ELECT | 330 20% 6.3 V |
| 1-124-604-00 | s | CAP, ELECT | 330 20% 10 V |
| 1-124-119-00 | s | CAP, ELECT | 330 20% 16 V |
| 1-124-479-11 | s | CAP, ELECT | 330 20% 25 V |
| 1-124-485-11 | s | CAP, ELECT | 330 20% 35 V |
| 1-124-912-11 | s | CAP, ELECT | 330 20% 50 V |
| 1-124-472-11 | s | CAP, ELECT | 470 20% 10 V |
| 1-124-475-11 | s | CAP, ELECT | 470 20% 16 V |
| 1-124-480-11 | s | CAP, ELECT | 470 20% 25 V |
| 1-126-104-11 | s | CAP, ELECT | 470 20% 35 V |
| 1-124-913-11 | s | CAP, ELECT | 470 20% 50 V |

RESISTOR

Replacements for resistors not given in board parts lists are shown in the following list.

| Part No. | SP | Description | |
|--------------|----|-------------|---------------|
| 1-215-373-31 | s | RES, METAL | 10 1% 1/6 W |
| 1-215-374-00 | s | RES, METAL | 11 1% 1/6 W |
| 1-215-375-00 | s | RES, METAL | 12 1% 1/6 W |
| 1-215-376-00 | s | RES, METAL | 13 1% 1/6 W |
| 1-215-377-00 | s | RES, METAL | 15 1% 1/6 W |
| 1-215-378-00 | s | RES, METAL | 16 1% 1/6 W |
| 1-215-379-00 | s | RES, METAL | 18 1% 1/6 W |
| 1-215-380-00 | s | RES, METAL | 20 1% 1/6 W |
| 1-215-381-00 | s | RES, METAL | 22 1% 1/6 W |
| 1-215-382-00 | s | RES, METAL | 24 1% 1/6 W |
| 1-215-383-00 | s | RES, METAL | 27 1% 1/6 W |
| 1-215-384-00 | s | RES, METAL | 30 1% 1/6 W |
| 1-215-385-00 | s | RES, METAL | 33 1% 1/6 W |
| 1-215-386-00 | s | RES, METAL | 36 1% 1/6 W |
| 1-215-387-00 | s | RES, METAL | 39 1% 1/6 W |
| 1-215-388-00 | s | RES, METAL | 43 1% 1/6 W |
| 1-215-389-00 | s | RES, METAL | 47 1% 1/6 W |
| 1-215-390-00 | s | RES, METAL | 51 1% 1/6 W |
| 1-215-391-00 | s | RES, METAL | 56 1% 1/6 W |
| 1-215-392-00 | s | RES, METAL | 62 1% 1/6 W |
| 1-215-393-00 | s | RES, METAL | 68 1% 1/6 W |
| 1-215-394-00 | s | RES, METAL | 75 1% 1/6 W |
| 1-215-395-00 | s | RES, METAL | 82 1% 1/6 W |
| 1-215-396-00 | s | RES, METAL | 91 1% 1/6 W |
| 1-215-397-00 | s | RES, METAL | 100 1% 1/6 W |
| 1-215-398-00 | s | RES, METAL | 110 1% 1/6 W |
| 1-215-399-00 | s | RES, METAL | 120 1% 1/6 W |
| 1-215-400-00 | s | RES, METAL | 130 1% 1/6 W |
| 1-215-401-00 | s | RES, METAL | 150 1% 1/6 W |
| 1-215-402-00 | s | RES, METAL | 160 1% 1/6 W |
| 1-215-403-00 | s | RES, METAL | 180 1% 1/6 W |
| 1-215-404-00 | s | RES, METAL | 200 1% 1/6 W |
| 1-215-405-00 | s | RES, METAL | 220 1% 1/6 W |
| 1-215-406-00 | s | RES, METAL | 240 1% 1/6 W |
| 1-215-407-00 | s | RES, METAL | 270 1% 1/6 W |
| 1-215-408-00 | s | RES, METAL | 300 1% 1/6 W |
| 1-215-409-00 | s | RES, METAL | 330 1% 1/6 W |
| 1-215-410-00 | s | RES, METAL | 360 1% 1/6 W |
| 1-215-411-00 | s | RES, METAL | 390 1% 1/6 W |
| 1-215-412-00 | s | RES, METAL | 430 1% 1/6 W |
| 1-215-413-00 | s | RES, METAL | 470 1% 1/6 W |
| 1-215-414-00 | s | RES, METAL | 510 1% 1/6 W |
| 1-215-415-00 | s | RES, METAL | 560 1% 1/6 W |
| 1-215-416-00 | s | RES, METAL | 620 1% 1/6 W |
| 1-215-417-00 | s | RES, METAL | 680 1% 1/6 W |
| 1-215-418-00 | s | RES, METAL | 750 1% 1/6 W |
| 1-215-419-00 | s | RES, METAL | 820 1% 1/6 W |
| 1-215-420-00 | s | RES, METAL | 910 1% 1/6 W |
| 1-215-421-00 | s | RES, METAL | 1.0k 1% 1/6 W |
| 1-215-422-00 | s | RES, METAL | 1.1k 1% 1/6 W |
| 1-215-423-00 | s | RES, METAL | 1.2k 1% 1/6 W |
| 1-215-424-00 | s | RES, METAL | 1.3k 1% 1/6 W |
| 1-215-425-00 | s | RES, METAL | 1.5k 1% 1/6 W |
| 1-215-426-00 | s | RES, METAL | 1.6k 1% 1/6 W |
| 1-215-427-00 | s | RES, METAL | 1.8k 1% 1/6 W |
| 1-215-428-00 | s | RES, METAL | 2.0k 1% 1/6 W |
| 1-215-429-00 | s | RES, METAL | 2.2k 1% 1/6 W |
| 1-215-430-00 | s | RES, METAL | 2.4k 1% 1/6 W |
| 1-215-431-00 | s | RES, METAL | 2.7k 1% 1/6 W |
| 1-215-432-00 | s | RES, METAL | 3.0k 1% 1/6 W |
| 1-215-433-00 | s | RES, METAL | 3.3k 1% 1/6 W |
| 1-215-434-00 | s | RES, METAL | 3.6k 1% 1/6 W |
| 1-215-435-00 | s | RES, METAL | 3.9k 1% 1/6 W |
| 1-215-436-00 | s | RES, METAL | 4.3k 1% 1/6 W |
| 1-215-437-00 | s | RES, METAL | 4.7k 1% 1/6 W |

(RESISTOR)

Replacements for resistors not given in board parts lists are shown in the following list.

| Part No. | SP | Description | |
|--------------|----|-------------|---------------|
| 1-215-438-00 | s | RES, METAL | 5.1k 1% 1/6 W |
| 1-215-439-00 | s | RES, METAL | 5.6k 1% 1/6 W |
| 1-215-440-00 | s | RES, METAL | 6.2k 1% 1/6 W |
| 1-215-441-00 | s | RES, METAL | 6.8k 1% 1/6 W |
| 1-215-442-00 | s | RES, METAL | 7.5k 1% 1/6 W |
| 1-215-443-00 | s | RES, METAL | 8.2k 1% 1/6 W |
| 1-215-444-00 | s | RES, METAL | 9.1k 1% 1/6 W |
| 1-215-445-00 | s | RES, METAL | 10k 1% 1/6 W |
| 1-215-446-00 | s | RES, METAL | 11k 1% 1/6 W |
| 1-215-447-00 | s | RES, METAL | 12k 1% 1/6 W |
| 1-215-448-00 | s | RES, METAL | 13k 1% 1/6 W |
| 1-215-449-00 | s | RES, METAL | 15k 1% 1/6 W |
| 1-215-450-00 | s | RES, METAL | 16k 1% 1/6 W |
| 1-215-451-00 | s | RES, METAL | 18k 1% 1/6 W |
| 1-215-452-00 | s | RES, METAL | 20k 1% 1/6 W |
| 1-215-453-00 | s | RES, METAL | 22k 1% 1/6 W |
| 1-215-454-00 | s | RES, METAL | 24k 1% 1/6 W |
| 1-215-455-00 | s | RES, METAL | 27k 1% 1/6 W |
| 1-215-456-00 | s | RES, METAL | 30k 1% 1/6 W |
| 1-215-457-00 | s | RES, METAL | 33k 1% 1/6 W |
| 1-215-458-00 | s | RES, METAL | 36k 1% 1/6 W |
| 1-215-459-00 | s | RES, METAL | 39k 1% 1/6 W |
| 1-215-460-00 | s | RES, METAL | 43k 1% 1/6 W |
| 1-215-461-00 | s | RES, METAL | 47k 1% 1/6 W |
| 1-215-462-00 | s | RES, METAL | 51k 1% 1/6 W |
| 1-215-463-00 | s | RES, METAL | 56k 1% 1/6 W |
| 1-215-464-00 | s | RES, METAL | 62k 1% 1/6 W |
| 1-215-465-00 | s | RES, METAL | 68k 1% 1/6 W |
| 1-215-466-00 | s | RES, METAL | 75k 1% 1/6 W |
| 1-215-467-00 | s | RES, METAL | 82k 1% 1/6 W |
| 1-215-468-00 | s | RES, METAL | 91k 1% 1/6 W |
| 1-215-469-00 | s | RES, METAL | 100k 1% 1/6 W |
| 1-215-470-00 | s | RES, METAL | 110k 1% 1/6 W |
| 1-215-471-00 | s | RES, METAL | 120k 1% 1/6 W |
| 1-215-472-00 | s | RES, METAL | 130k 1% 1/6 W |
| 1-215-473-00 | s | RES, METAL | 150k 1% 1/6 W |
| 1-215-474-00 | s | RES, METAL | 160k 1% 1/6 W |
| 1-215-475-00 | s | RES, METAL | 180k 1% 1/6 W |
| 1-215-476-00 | s | RES, METAL | 200k 1% 1/6 W |
| 1-215-477-00 | s | RES, METAL | 220k 1% 1/6 W |
| 1-215-478-00 | s | RES, METAL | 240k 1% 1/6 W |
| 1-215-479-00 | s | RES, METAL | 270k 1% 1/6 W |
| 1-215-480-00 | s | RES, METAL | 300k 1% 1/6 W |
| 1-215-481-00 | s | RES, METAL | 330k 1% 1/6 W |
| 1-215-482-00 | s | RES, METAL | 360k 1% 1/6 W |
| 1-215-483-00 | s | RES, METAL | 390k 1% 1/6 W |
| 1-215-484-00 | s | RES, METAL | 430k 1% 1/6 W |
| 1-215-485-00 | s | RES, METAL | 470k 1% 1/6 W |
| 1-215-486-00 | s | RES, METAL | 510k 1% 1/6 W |
| 1-215-487-00 | s | RES, METAL | 560k 1% 1/6 W |
| 1-215-488-00 | s | RES, METAL | 620k 1% 1/6 W |
| 1-215-489-00 | s | RES, METAL | 680k 1% 1/6 W |
| 1-215-490-00 | s | RES, METAL | 750k 1% 1/6 W |
| 1-215-491-00 | s | RES, METAL | 820k 1% 1/6 W |
| 1-215-492-00 | s | RES, METAL | 910k 1% 1/6 W |
| 1-215-493-00 | s | RES, METAL | 1.0M 1% 1/6 W |

AE-05 BOARD, DVR-1000

(AE-05 BOARD, DVR-1000)

| Ref. No. or Qty | Part No. | SP | Description |
|--------------------|--------------|----|--|
| 1pc | A-6013-084-A | o | AE-05 COMPLETE PCB, AE-05 (This assembly includes the following parts.) |
| 2pcs | 3-673-249-11 | o | LEVER, PC BOARD |
| 2pcs | 7-626-320-11 | o | PIN, SPRING 3X8 |
| 3pcs | 4-352-844-01 | s | PIN, LEAD, COATING |
| 6pcs | 7-622-207-05 | s | N 2.6, TYPE 2 |
| 6pcs | 7-628-254-30 | s | SCREW, +PS 2.6X10 |
| 1pc | 3-715-590-11 | o | LABEL, SERIAL NUMBER |
| 4pcs | 7-682-647-09 | s | SCREW +PS 3X6 |
| C102 | 1-124-247-00 | s | CAP, ELECT 10uF 20% 25V |
| C103 | 1-124-247-00 | s | CAP, ELECT 10uF 20% 25V |
| C104 | 1-131-365-00 | s | CAP, TANT 10uF 20% 20V |
| C105 | 1-130-471-00 | s | CAP, MYLAR 0.001uF 5% 50V |
| C106 | 1-123-661-00 | s | CAP, ELECT 100uF 20% 6.3V |
| C107 | 1-131-347-00 | s | CAP, TANT 1uF 20% 35V |
| C108 | 1-124-247-00 | s | CAP, ELECT 10uF 20% 25V |
| C109 | 1-124-247-00 | s | CAP, ELECT 10uF 20% 25V |
| C111 | 1-131-365-00 | s | CAP, TANT 10uF 20% 20V |
| C112 | 1-124-247-00 | s | CAP, ELECT 10uF 20% 25V |
| C113 | 1-124-247-00 | s | CAP, ELECT 10uF 20% 25V |
| C114 | 1-130-469-00 | s | CAP, MYLAR 680PF 5% 50V |
| C115 | 1-130-475-00 | s | CAP, MYLAR 0.0022uF 5% 50V |
| C116 | 1-130-472-00 | s | CAP, MYLAR 0.0012uF 5% 50V |
| C117 | 1-130-482-00 | s | CAP, MYLAR 0.0082uF 5% 50V |
| C119 | 1-130-494-11 | s | CAP, MYLAR 0.082uF 5% 50V |
| C120 | 1-131-365-00 | s | CAP, TANT 10uF 20% 20V |
| C121 | 1-130-475-00 | s | CAP, MYLAR 0.0022uF 5% 50V |
| C122 | 1-130-487-00 | s | CAP, MYLAR 0.022uF 5% 50V |
| C123 | 1-124-247-00 | s | CAP, ELECT 10uF 20% 25V |
| C124 | 1-124-247-00 | s | CAP, ELECT 10uF 20% 25V |
| C125 | 1-131-347-00 | s | CAP, TANT 1uF 20% 35V |
| C126 | 1-130-487-00 | s | CAP, MYLAR 0.022uF 5% 50V |
| C127 | 1-130-475-00 | s | CAP, MYLAR 0.0022uF 5% 50V |
| C128 | 1-130-467-00 | s | CAP, MYLAR 470PF 5% 50V |
| C129 | 1-130-468-00 | s | CAP, MYLAR 560PF 5% 50V |
| C130 | 1-109-561-00 | s | CAP, MICA 0.001uF 5% 100V |
| C132 | 1-131-365-00 | s | CAP, TANT 10uF 20% 20V |
| C134 | 1-131-395-00 | s | CAP, TANT 100uF 10% 3.15 |
| C135 | 1-130-477-00 | s | CAP, MYLAR 0.0033uF 5% 50V |
| C136 | 1-124-247-00 | s | CAP, ELECT 10uF 20% 25V |
| C137 | 1-124-247-00 | s | CAP, ELECT 10uF 20% 25V |
| C138 | 1-130-479-00 | s | CAP, MYLAR 0.0047uF 5% 50V |
| C139 | 1-130-480-00 | s | CAP, MYLAR 0.0056uF 5% 50V |
| C140 | 1-130-480-00 | s | CAP, MYLAR 0.0056uF 5% 50V |
| C141 | 1-130-471-00 | s | CAP, MYLAR 0.001uF 5% 50V |
| C142 | 1-131-365-00 | s | CAP, TANT 10uF 20% 20V |
| C143 | 1-123-661-00 | s | CAP, ELECT 100uF 20% 6.3V |
| C144 | 1-130-471-00 | s | CAP, MYLAR 0.001uF 5% 50V |
| C145 | 1-131-347-00 | s | CAP, TANT 1uF 20% 35V |
| C146 | 1-124-247-00 | s | CAP, ELECT 10uF 20% 25V |
| C147 | 1-124-247-00 | s | CAP, ELECT 10uF 20% 25V |
| C149 | 1-124-247-00 | s | CAP, ELECT 10uF 20% 25V |
| C150 | 1-124-247-00 | s | CAP, ELECT 10uF 20% 25V |
| C151 | 1-131-365-00 | s | CAP, TANT 10uF 20% 20V |
| C152 | 1-124-247-00 | s | CAP, ELECT 10uF 20% 25V |
| C153 | 1-124-247-00 | s | CAP, ELECT 10uF 20% 25V |
| C154 | 1-131-381-00 | s | CAP, TANT 47uF 10% 10V |
| C155 | 1-124-247-00 | s | CAP, ELECT 10uF 20% 25V |
| C156 | 1-124-247-00 | s | CAP, ELECT 10uF 20% 25V |
| C157 | 1-131-347-00 | s | CAP, TANT 1uF 20% 35V |
| C158 | 1-131-347-00 | s | CAP, TANT 1uF 20% 35V |
| C159 | 1-124-247-00 | s | CAP, ELECT 10uF 20% 25V |
| C160 | 1-124-247-00 | s | CAP, ELECT 10uF 20% 25V |
| C161 | 1-131-347-00 | s | CAP, TANT 1uF 20% 35V |
| C162 | 1-124-247-00 | s | CAP, ELECT 10uF 20% 25V |
| C163 | 1-124-247-00 | s | CAP, ELECT 10uF 20% 25V |
| C164 | 1-124-247-00 | s | CAP, ELECT 10uF 20% 25V |
| C165 | 1-124-247-00 | s | CAP, ELECT 10uF 20% 25V |
| C201 | 1-124-247-00 | s | CAP, ELECT 10uF 20% 25V |
| C202 | 1-124-247-00 | s | CAP, ELECT 10uF 20% 25V |
| C204 | 1-124-247-00 | s | CAP, ELECT 10uF 20% 25V |

| Ref. No. or Qty | Part No. | SP | Description |
|--------------------|--------------|----|----------------------------|
| C205 | 1-124-247-00 | s | CAP, ELECT 10uF 20% 25V |
| C206 | 1-131-363-00 | s | CAP, TANT 4.7uF 10% 16V |
| C207 | 1-130-468-00 | s | CAP, MYLAR 560PF 5% 50V |
| C208 | 1-131-367-00 | s | CAP, TANT 22uF 10% 20V |
| C209 | 1-130-494-11 | s | CAP, MYLAR 0.082uF 5% 50V |
| C210 | 1-131-365-00 | s | CAP, TANT 10uF 20% 20V |
| C211 | 1-130-475-00 | s | CAP, MYLAR 0.0022uF 5% 50V |
| C212 | 1-130-487-00 | s | CAP, MYLAR 0.022uF 5% 50V |
| C213 | 1-131-347-00 | s | CAP, TANT 1uF 20% 35V |
| C214 | 1-130-487-00 | s | CAP, MYLAR 0.022uF 5% 50V |
| C215 | 1-130-475-00 | s | CAP, MYLAR 0.0022uF 5% 50V |
| C216 | 1-130-467-00 | s | CAP, MYLAR 470PF 5% 50V |
| C217 | 1-130-468-00 | s | CAP, MYLAR 560PF 5% 50V |
| C218 | 1-124-247-00 | s | CAP, ELECT 10uF 20% 25V |
| C219 | 1-124-247-00 | s | CAP, ELECT 10uF 20% 25V |
| C220 | 1-109-561-00 | s | CAP, MICA 0.001uF 5% 100V |
| C222 | 1-130-491-00 | s | CAP, MYLAR 0.047uF 5% 50V |
| C223 | 1-130-478-00 | s | CAP, MYLAR 0.0039uF 5% 50V |
| C224 | 1-130-471-00 | s | CAP, MYLAR 0.001uF 5% 50V |
| C225 | 1-124-247-00 | s | CAP, ELECT 10uF 20% 25V |
| C226 | 1-124-247-00 | s | CAP, ELECT 10uF 20% 25V |
| C227 | 1-124-247-00 | s | CAP, ELECT 10uF 20% 25V |
| C228 | 1-124-247-00 | s | CAP, ELECT 10uF 20% 25V |
| C229 | 1-131-395-00 | s | CAP, TANT 100uF 10% 3.15 |
| C230 | 1-130-474-00 | s | CAP, MYLAR 0.0018uF 5% 50V |
| C231 | 1-130-479-00 | s | CAP, MYLAR 0.0047uF 5% 50V |
| C232 | 1-130-467-00 | s | CAP, MYLAR 470PF 5% 50V |
| C233 | 1-124-247-00 | s | CAP, ELECT 10uF 20% 25V |
| C234 | 1-124-247-00 | s | CAP, ELECT 10uF 20% 25V |
| C235 | 1-131-365-00 | s | CAP, TANT 10uF 20% 20V |
| C236 | 1-124-234-00 | s | CAP, ELECT 22uF 20% 16V |
| C237 | 1-130-473-00 | s | CAP, MYLAR 0.0015uF 5% 50V |
| C238 | 1-124-247-00 | s | CAP, ELECT 10uF 20% 25V |
| C239 | 1-124-247-00 | s | CAP, ELECT 10uF 20% 25V |
| C240 | 1-124-247-00 | s | CAP, ELECT 10uF 20% 25V |
| C241 | 1-124-247-00 | s | CAP, ELECT 10uF 20% 25V |
| C242 | 1-131-365-00 | s | CAP, TANT 10uF 20% 20V |
| C243 | 1-124-247-00 | s | CAP, ELECT 10uF 20% 25V |
| C244 | 1-124-247-00 | s | CAP, ELECT 10uF 20% 25V |
| C301 | 1-109-536-00 | s | CAP, MICA 110PF 5% 100V |
| C302 | 1-131-367-00 | s | CAP, TANT 22uF 10% 20V |
| C306 | 1-124-247-00 | s | CAP, ELECT 10uF 20% 25V |
| C307 | 1-124-247-00 | s | CAP, ELECT 10uF 20% 25V |
| C310 | 1-130-467-00 | s | CAP, MYLAR 470PF 5% 50V |
| C311 | 1-130-468-00 | s | CAP, MYLAR 560PF 5% 50V |
| C312 | 1-109-561-00 | s | CAP, MICA 0.001uF 5% 100V |
| C314 | 1-131-395-00 | s | CAP, TANT 100uF 10% 3.15 |
| C315 | 1-130-480-00 | s | CAP, MYLAR 0.0056uF 5% 50V |
| C316 | 1-124-247-00 | s | CAP, ELECT 10uF 20% 25V |
| C317 | 1-124-247-00 | s | CAP, ELECT 10uF 20% 25V |
| C318 | 1-130-479-00 | s | CAP, MYLAR 0.0047uF 5% 50V |
| C320 | 1-131-365-00 | s | CAP, TANT 10uF 20% 20V |
| C321 | 1-124-247-00 | s | CAP, ELECT 10uF 20% 25V |
| C322 | 1-124-247-00 | s | CAP, ELECT 10uF 20% 25V |
| C323 | 1-124-247-00 | s | CAP, ELECT 10uF 20% 25V |
| C324 | 1-124-247-00 | s | CAP, ELECT 10uF 20% 25V |
| C407 | 1-124-247-00 | s | CAP, ELECT 10uF 20% 25V |
| C408 | 1-124-247-00 | s | CAP, ELECT 10uF 20% 25V |
| C509 | 1-130-475-00 | s | CAP, MYLAR 0.0022uF 5% 50V |
| C510 | 1-130-487-00 | s | CAP, MYLAR 0.022uF 5% 50V |
| C511 | 1-131-347-00 | s | CAP, TANT 1uF 20% 35V |
| C512 | 1-130-487-00 | s | CAP, MYLAR 0.022uF 5% 50V |
| C514 | 1-130-468-00 | s | CAP, MYLAR 560PF 5% 50V |
| C515 | 1-124-247-00 | s | CAP, ELECT 10uF 20% 25V |
| C516 | 1-124-247-00 | s | CAP, ELECT 10uF 20% 25V |
| C517 | 1-124-247-00 | s | CAP, ELECT 10uF 20% 25V |
| C518 | 1-124-247-00 | s | CAP, ELECT 10uF 20% 25V |
| C519 | 1-109-561-00 | s | CAP, MICA 0.001uF 5% 100V |
| C520 | 1-130-475-00 | s | CAP, MYLAR 0.0022uF 5% 50V |
| C521 | 1-130-487-00 | s | CAP, MYLAR 0.022uF 5% 50V |

NOTE: Please see pages D-37 and D-38 for the part numbers of capacitors and resistors that are not listed in the parts list.

(AE-05 BOARD, DVR-1000)

| Ref. No. or Qty | Part No. | SP | Description |
|--------------------|--------------|----|----------------------------|
| C522 | 1-131-347-00 | s | CAP, TANT 1uF 20% 35V |
| C523 | 1-130-487-00 | s | CAP, MYLAR 0.022uF 5% 50V |
| C525 | 1-130-468-00 | s | CAP, MYLAR 560PF 5% 50V |
| C526 | 1-124-247-00 | s | CAP, ELECT 10uF 20% 25V |
| C527 | 1-124-247-00 | s | CAP, ELECT 10uF 20% 25V |
| C528 | 1-109-561-00 | s | CAP, MICA 0.001uF 5% 100V |
| C529 | 1-130-475-00 | s | CAP, MYLAR 0.0022uF 5% 50V |
| C530 | 1-130-487-00 | s | CAP, MYLAR 0.022uF 5% 50V |
| C531 | 1-130-487-00 | s | CAP, MYLAR 0.022uF 5% 50V |
| C533 | 1-130-468-00 | s | CAP, MYLAR 560PF 5% 50V |
| C536 | 1-130-483-00 | s | CAP, MYLAR 0.01uF 5% 50V |
| C537 | 1-130-483-00 | s | CAP, MYLAR 0.01uF 5% 50V |
| C538 | 1-109-637-00 | s | CAP, MICA 0.001uF 5% 500V |
| C539 | 1-131-347-00 | s | CAP, TANT 1uF 20% 35V |
| C540 | 1-124-247-00 | s | CAP, ELECT 10uF 20% 25V |
| C541 | 1-124-247-00 | s | CAP, ELECT 10uF 20% 25V |
| C601 | 1-130-473-00 | s | CAP, MYLAR 0.0015uF 5% 50V |
| C602 | 1-131-393-00 | s | CAP, TANT 47uF 10% 3.15 |
| C604 | 1-130-480-00 | s | CAP, MYLAR 0.0056uF 5% 50V |
| C605 | 1-131-347-00 | s | CAP, TANT 1uF 20% 35V |
| C608 | 1-130-473-00 | s | CAP, MYLAR 0.0015uF 5% 50V |
| C610 | 1-130-487-00 | s | CAP, MYLAR 0.022uF 5% 50V |
| C613 | 1-124-247-00 | s | CAP, ELECT 10uF 20% 25V |
| C614 | 1-124-247-00 | s | CAP, ELECT 10uF 20% 25V |
| C615 | 1-124-234-00 | s | CAP, ELECT 22uF 20% 16V |
| C616 | 1-124-234-00 | s | CAP, ELECT 22uF 20% 16V |
| C617 | 1-124-638-11 | s | CAP, ELECT 22uF 20% 6.3V |
| C618 | 1-124-638-11 | s | CAP, ELECT 22uF 20% 6.3V |
| C625 | 1-102-110-00 | s | CAP, CERAMIC 220PF 10% 50V |
| CN713 | 1-506-748-11 | s | RECEP, DIN 96P, MALE |
| CN714 | 1-506-746-11 | s | RECEP, DIN 48P, MALE |
| CN715 | 1-506-746-11 | s | RECEP, DIN 48P, MALE |
| D103 | 8-719-912-20 | s | DIODE 1SS120 |
| D104 | 8-719-912-20 | s | DIODE 1SS120 |
| D105 | 8-719-912-20 | s | DIODE 1SS120 |
| D106 | 8-719-912-20 | s | DIODE 1SS120 |
| D107 | 8-719-912-20 | s | DIODE 1SS120 |
| D108 | 8-719-100-30 | s | DIODE RD5.1E-B2 |
| D109 | 8-719-912-20 | s | DIODE 1SS120 |
| D201 | 8-719-912-20 | s | DIODE 1SS120 |
| D202 | 8-719-912-20 | s | DIODE 1SS120 |
| D203 | 8-719-912-20 | s | DIODE 1SS120 |
| D401 | 8-719-912-20 | s | DIODE 1SS120 |
| D402 | 8-719-400-35 | s | DIODE LN35BP |
| D403 | 8-719-400-35 | s | DIODE LN35BP |
| D501 | 8-719-912-20 | s | DIODE 1SS120 |
| D502 | 8-719-912-20 | s | DIODE 1SS120 |
| D503 | 8-719-912-20 | s | DIODE 1SS120 |
| D504 | 8-719-912-20 | s | DIODE 1SS120 |
| D505 | 8-719-912-20 | s | DIODE 1SS120 |
| D506 | 8-719-912-20 | s | DIODE 1SS120 |
| D507 | 8-719-912-20 | s | DIODE 1SS120 |
| D508 | 8-719-912-20 | s | DIODE 1SS120 |
| D509 | 8-719-912-20 | s | DIODE 1SS120 |
| D510 | 8-719-912-20 | s | DIODE 1SS120 |
| D511 | 8-719-912-20 | s | DIODE 1SS120 |
| D512 | 8-719-912-20 | s | DIODE 1SS120 |
| D513 | 8-719-912-20 | s | DIODE 1SS120 |
| IC101 | 8-759-701-21 | s | IC NJM5532D-D |
| IC102 | 8-759-603-82 | s | IC M5241L |
| IC103 | 8-759-040-53 | s | IC MC14053BCP |
| IC104 | 8-759-040-53 | s | IC MC14053BCP |
| IC105 | 8-759-745-59 | s | IC NJM4559D |
| IC106 | 8-759-602-83 | s | IC M5238P |
| IC107 | 8-759-602-83 | s | IC M5238P |
| IC108 | 8-759-700-04 | s | IC NJM2043D-D |
| IC109 | 8-759-602-83 | s | IC M5238P |
| IC110 | 8-759-040-53 | s | IC MC14053BCP |
| IC111 | 8-759-602-83 | s | IC M5238P |
| IC112 | 8-759-602-83 | s | IC M5238P |

(AE-05 BOARD, DVR-1000)

| Ref. No. or Qty | Part No. | SP | Description |
|--------------------|--------------|----|------------------------|
| IC113 | 8-759-040-53 | s | IC MC14053BCP |
| IC114 | 8-759-101-73 | s | IC UPC1513HA |
| IC115 | 8-759-103-19 | s | IC UPC319C |
| IC201 | 8-759-700-04 | s | IC NJM2043D-D |
| IC202 | 8-759-103-19 | s | IC UPC319C |
| IC203 | 8-759-040-53 | s | IC MC14053BCP |
| IC204 | 8-759-040-53 | s | IC MC14053BCP |
| IC205 | 8-759-602-83 | s | IC M5238P |
| IC206 | 8-759-602-83 | s | IC M5238P |
| IC207 | 8-759-745-59 | s | IC NJM4559D |
| IC208 | 8-759-101-73 | s | IC UPC1513HA |
| IC209 | 8-759-602-83 | s | IC M5238P |
| IC210 | 8-759-745-59 | s | IC NJM4559D |
| IC211 | 8-759-040-53 | s | IC MC14053BCP |
| IC301 | 8-759-602-83 | s | IC M5238P |
| IC302 | 8-759-602-83 | s | IC M5238P |
| IC303 | 8-759-040-53 | s | IC MC14053BCP |
| IC304 | 8-759-101-73 | s | IC UPC1513HA |
| IC305 | 8-759-602-83 | s | IC M5238P |
| IC306 | 8-759-103-19 | s | IC UPC319C |
| IC401 | 8-759-925-26 | s | IC CX23026 |
| IC402 | 8-759-925-26 | s | IC CX23026 |
| IC403 | 8-759-925-26 | s | IC CX23026 |
| IC404 | 1-567-794-11 | s | CRYSTAL 14.31818000MHz |
| IC405 | 8-759-103-19 | s | IC UPC319C |
| IC406 | 8-759-916-29 | s | IC SN74HC74N |
| IC407 | 8-759-916-29 | s | IC SN74HC74N |
| IC408 | 8-759-916-29 | s | IC SN74HC74N |
| IC409 | 8-759-925-26 | s | IC CX23026 |
| IC410 | 8-759-925-26 | s | IC CX23026 |
| IC411 | 8-759-921-08 | s | IC SN74HC02N |
| IC412 | 8-759-974-06 | s | IC SN7406N |
| IC413 | 8-759-250-20 | s | IC TC5020BP |
| IC414 | 8-759-202-21 | s | IC TC74HC32P |
| IC415 | 8-759-202-21 | s | IC TC74HC32P |
| IC416 | 8-759-202-74 | s | IC TC74HC04P |
| IC417 | 8-759-202-74 | s | IC TC74HC04P |
| IC418 | 8-759-803-70 | s | IC LC74HC08 |
| IC419 | 8-759-708-09 | s | IC NJM78L09A |
| IC420 | 8-759-700-68 | s | IC NJM79L09A |
| IC501 | 8-759-602-83 | s | IC M5238P |
| IC502 | 8-759-602-83 | s | IC M5238P |
| IC503 | 8-759-602-83 | s | IC M5238P |
| IC504 | 8-759-900-59 | s | IC HI1-0201-5 |
| IC601 | 8-759-906-07 | s | IC TL607CP |
| IC602 | 8-759-708-05 | s | IC NJM78L05A |
| IC603 | 8-759-700-65 | s | IC NJM79L05A |
| L101 | 1-410-450-11 | s | INDUCTOR, 3.9mH 10% |
| L102 | 1-410-439-11 | s | INDUCTOR, 470uH |
| L201 | 1-410-450-11 | s | INDUCTOR, 3.9mH 10% |
| L202 | 1-410-439-11 | s | INDUCTOR, 470uH |
| L301 | 1-410-450-11 | s | INDUCTOR, 3.9mH 10% |
| L302 | 1-410-439-11 | s | INDUCTOR, 470uH |
| L501 | 1-421-329-00 | s | COIL, CHOKE |
| L502 | 1-421-329-00 | s | COIL, CHOKE |
| L503 | 1-421-329-00 | s | COIL, CHOKE |
| L504 | 1-421-329-00 | s | COIL, CHOKE |
| L505 | 1-410-450-11 | s | INDUCTOR, 3.9mH 10% |
| L506 | 1-410-450-11 | s | INDUCTOR, 3.9mH 10% |
| L507 | 1-410-450-11 | s | INDUCTOR, 3.9mH 10% |
| LV101 | 1-407-286-00 | s | INDUCTOR, VAR 2.2mH |
| LV201 | 1-407-286-00 | s | INDUCTOR, VAR 2.2mH |
| LV301 | 1-407-286-00 | s | INDUCTOR, VAR 2.2mH |
| LV501 | 1-407-285-00 | s | INDUCTOR, VAR 1.5mH |
| LV502 | 1-407-284-00 | s | INDUCTOR, VAR 1mH |
| LV503 | 1-407-282-00 | s | INDUCTOR, VAR 0.47mH |
| Q201 | 8-729-900-36 | s | TRANSISTOR DTC124ES |
| Q301 | 8-729-900-36 | s | TRANSISTOR DTC124ES |
| Q501 | 8-729-169-02 | s | TRANSISTOR 2SC2690A |
| Q502 | 8-729-122-02 | s | TRANSISTOR 2SA1220A |

NOTE: Please see pages D-37 and D-38 for the part numbers of capacitors and resistors that are not listed in the parts list.

(AE-05 BOARD, DVR-1000)

| Ref. No. or Qty | Part No. | SP | Description |
|--------------------|--------------|----|--------------------------|
| Q503 | 8-729-169-02 | s | TRANSISTOR 2SC2690A |
| Q504 | 8-729-122-02 | s | TRANSISTOR 2SA1220A |
| Q505 | 8-729-600-60 | s | TRANSISTOR 2SA1115P |
| Q506 | 8-729-245-82 | s | TRANSISTOR 2SC2458-Y |
| Q507 | 8-729-265-52 | s | TRANSISTOR 2SC2655-O |
| Q508 | 8-729-374-02 | s | TRANSISTOR 2SB740 |
| R105 | 1-215-830-11 | s | RES, METAL 100K 1% 1/8W |
| R109 | 1-214-569-00 | s | RES, METAL 3.3K 1% 1/8W |
| R110 | 1-214-569-00 | s | RES, METAL 3.3K 1% 1/8W |
| R111 | 1-214-553-00 | s | RES, METAL 680 1% 1/8W |
| R113 | 1-214-553-00 | s | RES, METAL 680 1% 1/8W |
| R114 | 1-214-581-00 | s | RES, METAL 10K 1% 1/8W |
| R115 | 1-214-546-00 | s | RES, METAL 360 1% 1/8W |
| R116 | 1-214-545-00 | s | RES, METAL 330 1% 1/8W |
| R117 | 1-214-555-00 | s | RES, METAL 820 1% 1/8W |
| R118 | 1-214-557-00 | s | RES, METAL 1K 1% 1/8W |
| R119 | 1-214-581-00 | s | RES, METAL 10K 1% 1/8W |
| R122 | 1-214-574-00 | s | RES, METAL 5.1K 1% 1/8W |
| R123 | 1-214-574-00 | s | RES, METAL 5.1K 1% 1/8W |
| R126 | 1-214-579-00 | s | RES, METAL 8.2K 1% 1/8W |
| R127 | 1-247-881-00 | s | RES, CARBON 120K 5% 1/4W |
| R128 | 1-247-883-00 | s | RES, CARBON 150K 5% 1/4W |
| R129 | 1-214-580-00 | s | RES, METAL 9.1K 1% 1/8W |
| R130 | 1-214-590-00 | s | RES, METAL 24K 1% 1/8W |
| R131 | 1-214-550-00 | s | RES, METAL 510 1% 1/8W |
| R132 | 1-215-824-11 | s | RES, METAL 56K 1% 1/8W |
| R133 | 1-215-827-11 | s | RES, METAL 75K 1% 1/8W |
| R134 | 1-214-533-00 | s | RES, METAL 100 1% 1/8W |
| R135 | 1-214-557-00 | s | RES, METAL 1K 1% 1/8W |
| R136 | 1-247-887-00 | s | RES, CARBON 220K 5% 1/4W |
| R137 | 1-214-554-00 | s | RES, METAL 750 1% 1/8W |
| R138 | 1-214-545-00 | s | RES, METAL 330 1% 1/8W |
| R140 | 1-214-581-00 | s | RES, METAL 10K 1% 1/8W |
| R142 | 1-214-557-00 | s | RES, METAL 1K 1% 1/8W |
| R143 | 1-214-509-00 | s | RES, METAL 10 1% 1/8W |
| R144 | 1-214-509-00 | s | RES, METAL 10 1% 1/8W |
| R145 | 1-214-581-00 | s | RES, METAL 10K 1% 1/8W |
| R148 | 1-214-591-00 | s | RES, METAL 27K 1% 1/8W |
| R149 | 1-214-529-00 | s | RES, METAL 68 1% 1/8W |
| R150 | 1-214-545-00 | s | RES, METAL 330 1% 1/8W |
| R152 | 1-214-533-00 | s | RES, METAL 100 1% 1/8W |
| R153 | 1-214-533-00 | s | RES, METAL 100 1% 1/8W |
| R154 | 1-214-553-00 | s | RES, METAL 680 1% 1/8W |
| R155 | 1-247-895-00 | s | RES, CARBON 470K 5% 1/4W |
| R156 | 1-214-557-00 | s | RES, METAL 1K 1% 1/8W |
| R157 | 1-214-581-00 | s | RES, METAL 10K 1% 1/8W |
| R159 | 1-214-546-00 | s | RES, METAL 360 1% 1/8W |
| R160 | 1-214-545-00 | s | RES, METAL 330 1% 1/8W |
| R161 | 1-214-581-00 | s | RES, METAL 10K 1% 1/8W |
| R162 | 1-214-555-00 | s | RES, METAL 820 1% 1/8W |
| R163 | 1-214-533-00 | s | RES, METAL 100 1% 1/8W |
| R164 | 1-249-413-11 | s | RES, CARBON 470 5% 1/4W |
| R166 | 1-214-589-00 | s | RES, METAL 22K 1% 1/8W |
| R167 | 1-214-581-00 | s | RES, METAL 10K 1% 1/8W |
| R169 | 1-214-574-00 | s | RES, METAL 5.1K 1% 1/8W |
| R170 | 1-214-581-00 | s | RES, METAL 10K 1% 1/8W |
| R171 | 1-214-557-00 | s | RES, METAL 1K 1% 1/8W |
| R172 | 1-215-822-11 | s | RES, METAL 47K 1% 1/8W |
| R173 | 1-215-830-11 | s | RES, METAL 100K 1% 1/8W |
| R174 | 1-214-581-00 | s | RES, METAL 10K 1% 1/8W |
| R175 | 1-214-565-00 | s | RES, METAL 2.2K 1% 1/8W |
| R176 | 1-214-581-00 | s | RES, METAL 10K 1% 1/8W |
| R177 | 1-214-572-00 | s | RES, METAL 4.3K 1% 1/8W |
| R178 | 1-214-581-00 | s | RES, METAL 10K 1% 1/8W |
| R179 | 1-214-581-00 | s | RES, METAL 10K 1% 1/8W |
| R180 | 1-214-581-00 | s | RES, METAL 10K 1% 1/8W |
| R181 | 1-214-581-00 | s | RES, METAL 10K 1% 1/8W |
| R182 | 1-214-557-00 | s | RES, METAL 1K 1% 1/8W |

(AE-05 BOARD, DVR-1000)

| Ref. No. or Qty | Part No. | SP | Description |
|--------------------|--------------|----|--------------------------|
| R183 | 1-215-827-11 | s | RES, METAL 75K 1% 1/8W |
| R184 | 1-215-827-11 | s | RES, METAL 75K 1% 1/8W |
| R185 | 1-214-533-00 | s | RES, METAL 100 1% 1/8W |
| R186 | 1-214-549-00 | s | RES, METAL 470 1% 1/8W |
| R187 | 1-247-895-00 | s | RES, CARBON 470K 5% 1/4W |
| R188 | 1-214-569-00 | s | RES, METAL 3.3K 1% 1/8W |
| R201 | 1-214-581-00 | s | RES, METAL 10K 1% 1/8W |
| R202 | 1-214-581-00 | s | RES, METAL 10K 1% 1/8W |
| R203 | 1-214-581-00 | s | RES, METAL 10K 1% 1/8W |
| R204 | 1-214-581-00 | s | RES, METAL 10K 1% 1/8W |
| R205 | 1-214-592-00 | s | RES, METAL 30K 1% 1/8W |
| R206 | 1-214-592-00 | s | RES, METAL 30K 1% 1/8W |
| R207 | 1-215-822-11 | s | RES, METAL 47K 1% 1/8W |
| R208 | 1-214-563-00 | s | RES, METAL 1.8K 1% 1/8W |
| R210 | 1-214-557-00 | s | RES, METAL 1K 1% 1/8W |
| R213 | 1-214-592-00 | s | RES, METAL 30K 1% 1/8W |
| R214 | 1-214-581-00 | s | RES, METAL 10K 1% 1/8W |
| R215 | 1-215-820-11 | s | RES, METAL 39K 1% 1/8W |
| R216 | 1-214-581-00 | s | RES, METAL 10K 1% 1/8W |
| R217 | 1-214-557-00 | s | RES, METAL 1K 1% 1/8W |
| R218 | 1-214-557-00 | s | RES, METAL 1K 1% 1/8W |
| R219 | 1-247-887-00 | s | RES, CARBON 220K 5% 1/4W |
| R220 | 1-214-554-00 | s | RES, METAL 750 1% 1/8W |
| R222 | 1-214-545-00 | s | RES, METAL 330 1% 1/8W |
| R223 | 1-214-581-00 | s | RES, METAL 10K 1% 1/8W |
| R224 | 1-214-557-00 | s | RES, METAL 1K 1% 1/8W |
| R225 | 1-214-509-00 | s | RES, METAL 10 1% 1/8W |
| R226 | 1-214-509-00 | s | RES, METAL 10 1% 1/8W |
| R227 | 1-214-581-00 | s | RES, METAL 10K 1% 1/8W |
| R230 | 1-214-575-00 | s | RES, METAL 5.6K 1% 1/8W |
| R231 | 1-214-541-00 | s | RES, METAL 220 1% 1/8W |
| R232 | 1-214-577-00 | s | RES, METAL 6.8K 1% 1/8W |
| R234 | 1-214-579-00 | s | RES, METAL 8.2K 1% 1/8W |
| R235 | 1-214-558-00 | s | RES, METAL 1.1K 1% 1/8W |
| R236 | 1-214-557-00 | s | RES, METAL 1K 1% 1/8W |
| R237 | 1-214-593-00 | s | RES, METAL 33K 1% 1/8W |
| R239 | 1-215-823-11 | s | RES, METAL 51K 1% 1/8W |
| R240 | 1-214-574-00 | s | RES, METAL 5.1K 1% 1/8W |
| R241 | 1-215-821-11 | s | RES, METAL 43K 1% 1/8W |
| R242 | 1-214-578-00 | s | RES, METAL 7.5K 1% 1/8W |
| R243 | 1-214-533-00 | s | RES, METAL 100 1% 1/8W |
| R245 | 1-214-563-00 | s | RES, METAL 1.8K 1% 1/8W |
| R246 | 1-214-571-00 | s | RES, METAL 3.9K 1% 1/8W |
| R247 | 1-214-581-00 | s | RES, METAL 10K 1% 1/8W |
| R248 | 1-214-563-00 | s | RES, METAL 1.8K 1% 1/8W |
| R249 | 1-214-581-00 | s | RES, METAL 10K 1% 1/8W |
| R250 | 1-214-581-00 | s | RES, METAL 10K 1% 1/8W |
| R303 | 1-214-588-00 | s | RES, METAL 20K 1% 1/8W |
| R304 | 1-214-581-00 | s | RES, METAL 10K 1% 1/8W |
| R305 | 1-215-820-11 | s | RES, METAL 39K 1% 1/8W |
| R310 | 1-214-557-00 | s | RES, METAL 1K 1% 1/8W |
| R311 | 1-214-509-00 | s | RES, METAL 10 1% 1/8W |
| R312 | 1-214-509-00 | s | RES, METAL 10 1% 1/8W |
| R313 | 1-214-581-00 | s | RES, METAL 10K 1% 1/8W |
| R316 | 1-214-575-00 | s | RES, METAL 5.6K 1% 1/8W |
| R317 | 1-214-541-00 | s | RES, METAL 220 1% 1/8W |
| R320 | 1-214-579-00 | s | RES, METAL 8.2K 1% 1/8W |
| R321 | 1-214-588-00 | s | RES, METAL 20K 1% 1/8W |
| R322 | 1-214-558-00 | s | RES, METAL 1.1K 1% 1/8W |
| R323 | 1-214-557-00 | s | RES, METAL 1K 1% 1/8W |
| R324 | 1-215-823-11 | s | RES, METAL 51K 1% 1/8W |
| R325 | 1-247-883-00 | s | RES, CARBON 150K 5% 1/4W |
| R326 | 1-215-823-11 | s | RES, METAL 51K 1% 1/8W |
| R327 | 1-214-541-00 | s | RES, METAL 220 1% 1/8W |
| R328 | 1-214-574-00 | s | RES, METAL 5.1K 1% 1/8W |
| R368 | 1-214-565-00 | s | RES, METAL 2.2K 1% 1/8W |
| R401 | 1-214-581-00 | s | RES, METAL 10K 1% 1/8W |
| R403 | 1-214-563-00 | s | RES, METAL 1.8K 1% 1/8W |
| R404 | 1-214-540-00 | s | RES, METAL 200 1% 1/8W |
| R405 | 1-214-550-00 | s | RES, METAL 510 1% 1/8W |

NOTE: Please see pages D-37 and D-38 for the part numbers of capacitors and resistors that are not listed in the parts list.

(AE-05 BOARD, DVR-1000)

| Ref. No. or Qty | Part No. | SP | Description |
|--------------------|--------------|----|-----------------------------|
| R406 | 1-214-550-00 | s | RES. METAL 510 1% 1/8W |
| R407 | 1-214-541-00 | s | RES. METAL 220 1% 1/8W |
| R408 | 1-214-541-00 | s | RES. METAL 220 1% 1/8W |
| R409 | 1-214-565-00 | s | RES. METAL 2.2K 1% 1/8W |
| R410 | 1-214-565-00 | s | RES. METAL 2.2K 1% 1/8W |
| R411 | 1-214-571-00 | s | RES. METAL 3.9K 1% 1/8W |
| R412 | 1-214-579-00 | s | RES. METAL 8.2K 1% 1/8W |
| R413 | 1-214-550-00 | s | RES. METAL 510 1% 1/8W |
| R502 | 1-214-581-00 | s | RES. METAL 10K 1% 1/8W |
| R503 | 1-214-554-00 | s | RES. METAL 750 1% 1/8W |
| R504 | 1-214-557-00 | s | RES. METAL 1K 1% 1/8W |
| R505 | 1-214-557-00 | s | RES. METAL 1K 1% 1/8W |
| R506 | 1-249-387-11 | s | RES. CARBON 3.3 5% 1/4W |
| R507 | 1-249-387-11 | s | RES. CARBON 3.3 5% 1/4W |
| R508 | 1-249-447-11 | s | RES. CARBON 1 5% 1/4W |
| R510 | 1-214-581-00 | s | RES. METAL 10K 1% 1/8W |
| R511 | 1-214-554-00 | s | RES. METAL 750 1% 1/8W |
| R512 | 1-214-557-00 | s | RES. METAL 1K 1% 1/8W |
| R513 | 1-214-557-00 | s | RES. METAL 1K 1% 1/8W |
| R514 | 1-249-387-11 | s | RES. CARBON 3.3 5% 1/4W |
| R515 | 1-249-387-11 | s | RES. CARBON 3.3 5% 1/4W |
| R516 | 1-249-447-11 | s | RES. CARBON 1 5% 1/4W |
| R518 | 1-214-581-00 | s | RES. METAL 10K 1% 1/8W |
| R519 | 1-214-554-00 | s | RES. METAL 750 1% 1/8W |
| R520 | 1-214-561-00 | s | RES. METAL 1.5K 1% 1/8W |
| R521 | 1-214-553-00 | s | RES. METAL 680 1% 1/8W |
| R522 | 1-214-553-00 | s | RES. METAL 680 1% 1/8W |
| R523 | 1-214-561-00 | s | RES. METAL 1.5K 1% 1/8W |
| R524 | 1-249-387-11 | s | RES. CARBON 3.3 5% 1/4W |
| R525 | 1-249-387-11 | s | RES. CARBON 3.3 5% 1/4W |
| R526 | 1-249-447-11 | s | RES. CARBON 1 5% 1/4W |
| R608 | 1-215-830-11 | s | RES. METAL 100K 1% 1/8W |
| R609 | 1-214-525-00 | s | RES. METAL 47 1% 1/8W |
| R610 | 1-214-525-00 | s | RES. METAL 47 1% 1/8W |
| R611 | 1-214-581-00 | s | RES. METAL 10K 1% 1/8W |
| R612 | 1-214-581-00 | s | RES. METAL 10K 1% 1/8W |
| R617 | 1-214-550-00 | s | RES. METAL 510 1% 1/8W |
| R618 | 1-214-562-00 | s | RES. METAL 1.6K 1% 1/8W |
| R619 | 1-214-557-00 | s | RES. METAL 1K 1% 1/8W |
| RB601 | 1-231-533-00 | s | RESISTOR BLOCK, 10K x 4 |
| RV101 | 1-228-458-00 | s | RES. VAR. CERMET 5K |
| RV102 | 1-228-456-00 | s | RES. VAR. CERMET 1K |
| RV103 | 1-228-457-00 | s | RES. VAR. CERMET 2K |
| RV104 | 1-228-476-00 | s | RES. VAR. CERMET 50K |
| RV105 | 1-228-473-00 | s | RES. VAR. CERMET 5K |
| RV106 | 1-228-455-00 | s | RES. VAR. CERMET 500 |
| RV107 | 1-228-460-00 | s | RES. VAR. CERMET 20K |
| RV108 | 1-228-458-00 | s | RES. VAR. CERMET 5K |
| RV109 | 1-228-460-00 | s | RES. VAR. CERMET 20K |
| RV121 | 1-228-459-00 | s | RES. VAR. CERMET 10K |
| RV168 | 1-228-457-00 | s | RES. VAR. CERMET 2K |
| RV201 | 1-228-472-00 | s | RES. VAR. CERMET 2K |
| RV202 | 1-228-455-00 | s | RES. VAR. CERMET 500 |
| RV203 | 1-228-459-00 | s | RES. VAR. CERMET 10K |
| RV204 | 1-228-462-00 | s | RES. VAR. CERMET 100K |
| RV205 | 1-228-476-00 | s | RES. VAR. CERMET 50K |
| RV206 | 1-228-462-00 | s | RES. VAR. CERMET 100K |
| RV301 | 1-228-472-00 | s | RES. VAR. CERMET 2K |
| RV303 | 1-228-462-00 | s | RES. VAR. CERMET 100K |
| RV304 | 1-228-477-00 | s | RES. VAR. CERMET 100K |
| RV305 | 1-228-462-00 | s | RES. VAR. CERMET 100K |
| RV501 | 1-228-455-00 | s | RES. VAR. CERMET 500 |
| RV502 | 1-228-455-00 | s | RES. VAR. CERMET 500 |
| RV503 | 1-228-455-00 | s | RES. VAR. CERMET 500 |
| TH101 | 1-807-749-11 | s | THERMISTOR. POSITIVE 68-OHM |
| TH102 | 1-807-749-11 | s | THERMISTOR. POSITIVE 68-OHM |
| TH601 | 1-800-200-00 | s | THERMISTOR S-3K |

AH-13 BOARD, DVR-1000

| Ref. No. or Qty | Part No. | SP | Description |
|--------------------|--------------|----|--------------------------------------|
| 1pc | 1-620-899-12 | o | PC BOARD, AH-13 WITHOUT COMPONENT |
| CN432M | 1-506-467-31 | o | CONNECTOR, 2P, MALE |
| CN430M | 1-506-467-41 | o | CONNECTOR, 2P, MALE |
| CN433M | 1-506-471-11 | o | CONNECTOR, 6P, MALE |

NOTE: Please see pages D-37 and D-38 for the part numbers of capacitors and resistors that are not listed in the parts list.

AH-15 BOARD, DVR-1000

| Ref. No. or Qty | Part No. | SP | Description |
|--------------------|--------------|----|--------------------------------------|
| 1pc | 1-620-947-12 | o | PC BOARD, AH-15 WITHOUT COMPONENT |
| CN434M | 1-506-467-21 | o | CONNECTOR, 2P, MALE |

BP-10 BOARD, DVR-1000

| Ref. No. or Qty | Part No. | SP | Description |
|--------------------|--------------|----|--------------------------------------|
| 1pc | 1-620-912-11 | o | PC BOARD, BP-10 WITHOUT COMPONENT |
| CN414M | 1-506-631-11 | o | RECEP, PS 4P, MALE |
| CN415M | 1-506-631-11 | o | RECEP, PS 4P, MALE |
| CN416M | 1-506-472-11 | o | RECEP, 7P, MALE |
| CN417M | 1-506-469-11 | o | RECEP, 4P, MALE |
| CN418M | 1-506-468-11 | o | RECEP, 3P, MALE |

NOTE: Please see pages D-37 and D-38 for the part numbers of capacitors and resistors that are not listed in the parts list.

CC-29 BOARD, DVR-1000

| Ref. No. or Qty | Part No. | SP | Description |
|--------------------|--------------|----|--------------------------------------|
| 1pc | 1-620-911-11 | o | PC BOARD, CC-29 WITHOUT COMPONENT |
| CN1 | 1-562-884-11 | o | CONNECTOR, FPC 4P |
| R1 | 1-249-413-11 | s | RES, CARBON 470 5% 1/6W |
| R2 | 1-249-413-11 | s | RES, CARBON 470 5% 1/6W |

CD-35 BOARD, DVR-1000

| Ref. No. or Qty | Part No. | SP | Description |
|--------------------|--------------|----|--|
| 1pc | A-6015-104-A | o | COMPLETE PCB, CD-35 (This assembly includes the following parts.) |
| 1pc | 3-715-590-21 | o | LABEL, SERIAL NUMBER |
| 2pcs | 3-673-249-00 | o | LEVER, PC BOARD |
| 2pcs | 7-626-320-11 | o | PIN, SPRING 3X8 |
| 4pcs | 7-628-254-30 | s | +PSW, 2.6X10 |
| 4pcs | 7-622-207-05 | s | N 2.6, TYPE 2 |
| 4pcs | 7-682-647-09 | s | SCREW +PWH 3X6 |
| C1 | 1-124-236-00 | s | CAP, ELECT 47uF 20% 16V |
| C3 | 1-124-236-00 | s | CAP, ELECT 47uF 20% 16V |
| C5 | 1-123-661-00 | s | CAP, ELECT 100uF 20% 6.3V |
| C7 | 1-123-661-00 | s | CAP, ELECT 100uF 20% 6.3V |
| C9 | 1-130-483-00 | s | CAP, MYLAR 0.01uF 5% 50V |
| C10 | 1-130-487-00 | s | CAP, MYLAR 0.022uF 5% 50V |
| C11 | 1-130-471-00 | s | CAP, MYLAR 0.001uF 5% 50V |
| C12 | 1-130-483-00 | s | CAP, MYLAR 0.01uF 5% 50V |
| C13 | 1-124-598-11 | s | CAP, ELECT 22uF 20% 25V |
| C15 | 1-161-375-00 | s | CAP, CERAMIC 0.0022uF 20% 50V |
| C16 | 1-124-598-11 | s | CAP, ELECT 22uF 20% 25V |
| C17 | 1-124-598-11 | s | CAP, ELECT 22uF 20% 25V |
| C18 | 1-124-598-11 | s | CAP, ELECT 22uF 20% 25V |
| C29 | 1-124-598-11 | s | CAP, ELECT 22uF 20% 25V |
| C33 | 1-124-259-00 | s | CAP, ELECT 4.7uF 20% 50V |
| C34 | 1-124-259-00 | s | CAP, ELECT 4.7uF 20% 50V |
| C39 | 1-162-286-31 | s | CAP, CERAMIC 220PF 10% 50V |
| C40 | 1-162-294-31 | s | CAP, CERAMIC 0.001uF 10% 50V |
| C41 | 1-161-379-00 | s | CAP, CERAMIC 0.01uF 20% 25V |
| C46 | 1-162-757-11 | s | CAP, CERAMIC 220PF 5% 50V |
| C48 | 1-162-757-11 | s | CAP, CERAMIC 220PF 5% 50V |
| C61 | 1-130-491-00 | s | CAP, MYLAR 0.047uF 5% 50V |
| C62 | 1-130-491-00 | s | CAP, MYLAR 0.047uF 5% 50V |
| C63 | 1-162-294-31 | s | CAP, CERAMIC 0.001uF 10% 50V |
| C64 | 1-130-491-00 | s | CAP, MYLAR 0.047uF 5% 50V |
| C70 | 1-130-483-00 | s | CAP, MYLAR 0.01uF 5% 50V |
| C71 | 1-130-483-00 | s | CAP, MYLAR 0.01uF 5% 50V |
| C87 | 1-161-294-31 | s | CAP, CERAMIC 1000P 10% 50V |
| C517 | 1-123-661-00 | s | CAP, ELECT 100uF 20% 6.3V |
| CN718M | 1-506-748-11 | s | RECEP, DIN 96P, MALE |
| CN719M | 1-506-746-11 | s | RECEP, DIN 48P, MALE |
| D2 | 8-719-933-28 | s | DIODE DAP209S |
| D4 | 8-719-933-28 | s | DIODE DAP209S |
| D5 | 8-719-815-55 | s | DIODE 1S1555 |
| D10 | 8-719-933-30 | s | DIODE DA210S |
| D11 | 8-719-933-30 | s | DIODE DA210S |
| ICA1 | 8-759-145-58 | s | IC uPC4558C |
| ICA2 | 8-759-145-58 | s | IC uPC4558C |
| ICA3 | 8-759-103-06 | s | IC uPC398C |
| ICA4 | 8-759-240-53 | s | IC TC4053BP |
| ICA5 | 8-759-240-53 | s | IC TC4053BP |
| ICA13 | 8-759-001-39 | s | IC MC74HC164N |
| ICA14 | 8-759-202-24 | s | IC TC74HC86P |
| ICA16 | 8-759-916-29 | s | IC SN74HC74N |
| ICA18 | 8-759-202-97 | s | IC TC74HC165P |
| ICA19 | 8-759-803-70 | s | IC LC74HC08 |
| ICA20 | 8-759-202-11 | s | IC TC74HC00P |
| ICA21 | 8-759-916-29 | s | IC SN74HC74N |
| ICB1 | 8-759-990-82 | s | IC TL082CP |
| ICB2 | 8-759-103-06 | s | IC uPC398C |
| ICB3 | 8-759-103-19 | s | IC uPC319C |
| ICB4 | 8-759-103-19 | s | IC uPC319C |
| ICB5 | 8-759-135-80 | s | IC uPC358C |
| ICB6 | 8-759-910-43 | s | IC CX23028 |
| ICB7 | 8-759-803-70 | s | IC LC74HC08 |
| ICB8 | 8-759-203-36 | s | IC TC74HC374P |
| ICB9 | 8-759-203-36 | s | IC TC74HC374P |
| ICB10 | 8-759-917-05 | s | IC SN74HC54IN |
| ICB11 | 8-759-917-05 | s | IC SN74HC54IN |
| ICB12 | 8-759-938-83 | s | IC CF77074NT |
| ICB15 | 8-759-916-50 | s | IC SN74HC157N |
| ICB16 | 8-759-203-01 | s | IC TC74HC175P |
| ICB18 | 8-759-000-73 | s | IC MC14516BCP |
| ICB19 | 8-759-001-39 | s | IC MC74HC164N |

NOTE: Please see pages D-37 and D-38 for the part numbers of capacitors and resistors that are not listed in the parts list.

(CD-35 BOARD, DVR-1000)

| Ref. No. or Qty | Part No. | SP | Description |
|-------------------------------|--------------|----|--------------------------|
| 2/(XD-35 BOARD, DVR-1000)D-45 | | | |
| ICC3 | 8-759-990-82 | s | IC TL082CP |
| ICC4 | 8-759-145-58 | s | IC uPC4558C |
| ICC5 | 8-759-240-52 | s | IC TC4052BP |
| ICC6 | 8-759-000-77 | s | IC MC14520BCP |
| ICC7 | 8-759-916-29 | s | IC SN74HC74N |
| ICC8 | 8-759-107-52 | s | IC CXQ71054P |
| ICC10 | 8-759-938-83 | s | IC CF77074NT |
| ICC11 | 8-759-107-52 | s | IC CXQ71054P |
| ICC12 | 8-759-107-52 | s | IC CXQ71054P |
| ICC14 | 8-759-107-52 | s | IC CXQ71054P |
| ICC15 | 8-759-202-11 | s | IC TC74HC00P |
| ICC16 | 8-759-803-70 | s | IC LC74HC08 |
| ICC17 | 8-759-202-21 | s | IC TC74HC32P |
| ICD2 | 8-759-990-82 | s | IC TL082CP |
| ICD3 | 8-759-990-82 | s | IC TL082CP |
| ICD4 | 8-759-103-93 | s | IC uPC393C |
| ICD5 | 8-759-000-47 | s | IC MC14051BCP |
| ICD6 | 8-759-202-74 | s | IC TC74HC04P |
| ICD7 | 8-759-202-26 | s | IC TC74HC138P |
| ICD8 | 8-759-202-26 | s | IC TC74HC138P |
| ICD9 | 8-759-202-26 | s | IC TC74HC138P |
| ICD10 | 8-759-921-34 | s | IC SN74HC245N |
| ICD11 | 8-759-202-74 | s | IC TC74HC04P |
| ICD12 | 8-759-203-68 | s | IC TC74HC0404P |
| ICD13 | 8-759-917-05 | s | IC SN74HC541N |
| ICD14 | 8-759-203-08 | s | IC TC74HC221P |
| ICD16 | 8-759-916-35 | s | IC SN74HC107N |
| ICD17 | 8-759-001-42 | s | IC MC74HC174N |
| ICD18 | 8-759-001-42 | s | IC MC74HC174N |
| ICD19 | 8-759-203-68 | s | IC TC74HC0404P |
| ICD20 | 8-759-788-95 | s | IC MBM27C64-CD350211 |
| L1 | 1-421-329-00 | s | COIL, CHOKE |
| L2 | 1-421-329-00 | s | COIL, CHOKE |
| L3 | 1-421-329-00 | s | COIL, CHOKE |
| L4 | 1-421-329-00 | s | COIL, CHOKE |
| Q1 | 8-729-697-92 | s | TRANSISTOR 2SA979 |
| Q2 | 8-729-697-92 | s | TRANSISTOR 2SA979 |
| R1 | 1-249-431-11 | s | RES. CARBON 15K 5% 1/6W |
| R6 | 1-249-429-11 | s | RES. CARBON 10K 5% 1/6W |
| R19 | 1-249-433-11 | s | RES. CARBON 22K 5% 1/6W |
| R29 | 1-249-393-11 | s | RES. CARBON 10 5% 1/6W |
| R30 | 1-249-441-11 | s | RES. CARBON 100K 5% 1/6W |
| R31 | 1-249-411-11 | s | RES. CARBON 330 5% 1/6W |
| R32 | 1-249-411-11 | s | RES. CARBON 330 5% 1/6W |
| R33 | 1-249-429-11 | s | RES. CARBON 10K 5% 1/6W |
| R34 | 1-249-421-11 | s | RES. CARBON 2.2K 5% 1/6W |
| R36 | 1-249-441-11 | s | RES. CARBON 100K 5% 1/6W |
| R39 | 1-249-421-11 | s | RES. CARBON 2.2K 5% 1/6W |
| R41 | 1-249-441-11 | s | RES. CARBON 100K 5% 1/6W |
| R42 | 1-249-421-11 | s | RES. CARBON 2.2K 5% 1/6W |
| R44 | 1-249-441-11 | s | RES. CARBON 100K 5% 1/6W |
| R45 | 1-249-429-11 | s | RES. CARBON 10K 5% 1/6W |
| R46 | 1-249-429-11 | s | RES. CARBON 10K 5% 1/6W |
| R47 | 1-249-429-11 | s | RES. CARBON 10K 5% 1/6W |
| R48 | 1-249-429-11 | s | RES. CARBON 10K 5% 1/6W |
| R49 | 1-249-429-11 | s | RES. CARBON 10K 5% 1/6W |
| R50 | 1-249-429-11 | s | RES. CARBON 10K 5% 1/6W |
| R51 | 1-249-429-11 | s | RES. CARBON 10K 5% 1/6W |
| R54 | 1-249-429-11 | s | RES. CARBON 10K 5% 1/6W |
| R55 | 1-249-429-11 | s | RES. CARBON 10K 5% 1/6W |
| R63 | 1-249-441-11 | s | RES. CARBON 100K 5% 1/6W |
| R70 | 1-249-421-11 | s | RES. CARBON 2.2K 5% 1/6W |
| R77 | 1-249-429-11 | s | RES. CARBON 10K 5% 1/6W |
| R81 | 1-249-433-11 | s | RES. CARBON 22K 5% 1/6W |
| R82 | 1-249-433-11 | s | RES. CARBON 22K 5% 1/6W |
| R83 | 1-249-424-11 | s | RES. CARBON 3.9K 5% 1/6W |
| R84 | 1-249-429-11 | s | RES. CARBON 10K 5% 1/6W |
| R85 | 1-249-411-11 | s | RES. CARBON 330 5% 1/6W |
| R86 | 1-249-441-11 | s | RES. CARBON 100K 5% 1/6W |
| R87 | 1-249-411-11 | s | RES. CARBON 330 5% 1/6W |

(CD-35 BOARD, DVR-1000)

| Ref. No. or Qty | Part No. | SP | Description |
|--------------------|--------------|----|--------------------------|
| R90 | 1-249-411-11 | s | RES. CARBON 330 5% 1/6W |
| R91 | 1-249-441-11 | s | RES. CARBON 100K 5% 1/6W |
| R92 | 1-249-411-11 | s | RES. CARBON 330 5% 1/6W |
| R94 | 1-249-411-11 | s | RES. CARBON 330 5% 1/6W |
| R95 | 1-249-411-11 | s | RES. CARBON 330 5% 1/6W |
| R103 | 1-249-429-11 | s | RES. CARBON 10K 5% 1/6W |
| R104 | 1-249-429-11 | s | RES. CARBON 10K 5% 1/6W |
| R105 | 1-249-441-11 | s | RES. CARBON 100K 5% 1/6W |
| R107 | 1-249-425-11 | s | RES. CARBON 4.7K 5% 1/6W |
| R108 | 1-249-432-11 | s | RES. CARBON 18K 5% 1/6W |
| R109 | 1-249-432-11 | s | RES. CARBON 18K 5% 1/6W |
| R110 | 1-249-441-11 | s | RES. CARBON 100K 5% 1/6W |
| R111 | 1-249-393-11 | s | RES. CARBON 10 5% 1/6W |
| R114 | 1-249-437-11 | s | RES. CARBON 47K 5% 1/6W |
| R115 | 1-249-429-11 | s | RES. CARBON 10K 5% 1/6W |
| R116 | 1-249-433-11 | s | RES. CARBON 22K 5% 1/6W |
| R117 | 1-249-437-11 | s | RES. CARBON 47K 5% 1/6W |
| R123 | 1-249-393-11 | s | RES. CARBON 10 5% 1/6W |
| R126 | 1-249-393-11 | s | RES. CARBON 10 5% 1/6W |
| R127 | 1-249-393-11 | s | RES. CARBON 10 5% 1/6W |
| RB1 | 1-235-005-00 | s | RESISTOR BLOCK, 47KX8 |
| RB2 | 1-235-005-00 | s | RESISTOR BLOCK, 47KX8 |

NOTE: Please see pages D-37 and D-38 for the part numbers of capacitors and resistors that are not listed in the parts list.

CN-157 BOARD, DVR-1000

| Ref. No. or Qty | Part No. | SP | Description |
|--------------------|--------------|----|---------------------------------------|
| 1pc | 1-620-892-11 | o | PC BOARD, CN-157 WITHOUT COMPONENT |
| CN405 | 1-562-992-11 | o | CONNECTOR, FPC 26P |
| CN406M | 1-506-637-11 | o | RECEP, PS 16P, MALE |
| CN407M | 1-506-470-11 | o | RECEP, 5P, MALE |

CN-191 BOARD, DVR-1000

| Ref. No. or Qty | Part No. | SP | Description |
|--------------------|--------------|----|---------------------------------------|
| 1pc | 1-621-346-11 | o | PC BOARD, CN-191 WITHOUT COMPONENT |
| C1 | 1-162-806-11 | s | CAP, CERAMIC 0.1uF 10% 50V |
| C2 | 1-162-806-11 | s | CAP, CERAMIC 0.1uF 10% 50V |
| C3 | 1-162-806-11 | s | CAP, CERAMIC 0.1uF 10% 50V |
| C4 | 1-162-806-11 | s | CAP, CERAMIC 0.1uF 10% 50V |

NOTE: Please see pages D-37 and D-38 for the part numbers of capacitors and resistors that are not listed in the parts list.

CP-106 BOARD, DVR-1000

| Ref. No. or Qty | Part No. | SP | Description |
|--------------------|--------------|----|---|
| 1pc | A-6017-145-A | o | COMPLETE PCB, CP-106 (This assembly includes the following parts.) |
| BT1 | 1-528-218-11 | s | BATTERY, LITHIUM CR2032WT13H |
| C1 | 1-163-038-00 | s | CAP, CERAMIC 0.1uF 25V |
| C2 | 1-163-038-00 | s | CAP, CERAMIC 0.1uF 25V |
| C3 | 1-163-038-00 | s | CAP, CERAMIC 0.1uF 25V |
| C4 | 1-124-236-00 | s | CAP, ELECT 47uF 20% 16V |
| C5 | 1-163-038-00 | s | CAP, CERAMIC 0.1uF 25V |
| C6 | 1-163-038-00 | s | CAP, CERAMIC 0.1uF 25V |
| C7 | 1-163-038-00 | s | CAP, CERAMIC 0.1uF 25V |
| C8 | 1-163-038-00 | s | CAP, CERAMIC 0.1uF 25V |
| C9 | 1-163-038-00 | s | CAP, CERAMIC 0.1uF 25V |
| C10 | 1-163-038-00 | s | CAP, CERAMIC 0.1uF 25V |
| C11 | 1-163-038-00 | s | CAP, CERAMIC 0.1uF 25V |
| C12 | 1-163-038-00 | s | CAP, CERAMIC 0.1uF 25V |
| C13 | 1-163-038-00 | s | CAP, CERAMIC 0.1uF 25V |
| C14 | 1-163-038-00 | s | CAP, CERAMIC 0.1uF 25V |
| C15 | 1-163-038-00 | s | CAP, CERAMIC 0.1uF 25V |
| C16 | 1-163-038-00 | s | CAP, CERAMIC 0.1uF 25V |
| C17 | 1-124-236-00 | s | CAP, ELECT 47uF 20% 16V |
| C18 | 1-163-038-00 | s | CAP, CERAMIC 0.1uF 25V |
| C19 | 1-163-038-00 | s | CAP, CERAMIC 0.1uF 25V |
| C20 | 1-163-038-00 | s | CAP, CERAMIC 0.1uF 25V |
| CN501M | 1-566-405-21 | o | RECEP, 30P, MALE |
| DL1 | 1-415-502-11 | s | DELAY LINE, 100ns |
| FB1 | 1-535-178-00 | s | FERRITE BEAD |
| IC1 | 8-759-112-41 | s | IC uPD71059G |
| IC2 | 8-759-112-43 | s | IC uPD71054G |
| IC3 | 8-759-939-36 | s | IC TL7705ACP |
| IC4 | 8-759-112-42 | s | IC uPD71011G |
| IC5 | 8-759-941-28 | s | IC MB671131PF |
| IC6 | 8-759-104-08 | s | IC uPD4364G-15L |
| IC7 | 8-759-733-66 | s | IC MBM27C512-CP1060130 |
| IC8 | 8-759-103-24 | s | IC uPD7201AD |
| IC9 | 8-759-111-90 | s | IC uPD7220AD-2 |
| IC10 | 8-759-939-28 | s | IC CXD1102Q |
| IC11 | 8-759-112-49 | s | IC uPD43256G-10L |
| IC12 | 8-759-939-61 | s | IC DS1210 |
| IC13 | 8-759-733-67 | s | IC MBM27C512-CP1060230 |
| IC14 | 8-759-733-65 | s | IC MBM27C512-CP1060330 |
| IC15 | 8-759-105-75 | s | IC uPD70108D-8 |
| IC16 | 8-759-107-02 | s | IC uPD74HC245G |
| IC17 | 8-759-205-23 | s | IC TC74HC244F |
| IC18 | 8-759-204-98 | s | IC TC74HC08F |
| IC19 | 8-759-112-49 | s | IC uPD43256G-10L |
| R1 | 1-249-429-11 | s | RES, CARBON 10K 5% 1/6W |
| R2 | 1-249-429-11 | s | RES, CARBON 10K 5% 1/6W |
| R3 | 1-249-429-11 | s | RES, CARBON 10K 5% 1/6W |
| R4 | 1-249-429-11 | s | RES, CARBON 10K 5% 1/6W |
| R5 | 1-249-437-11 | s | RES, CARBON 47K 5% 1/6W |
| R6 | 1-249-411-11 | s | RES, CARBON 330 5% 1/6W |
| R7 | 1-249-437-11 | s | RES, CARBON 47K 5% 1/6W |
| R8 | 1-249-429-11 | s | RES, CARBON 10K 5% 1/6W |
| R9 | 1-249-417-11 | s | RES, CARBON 1K 5% 1/6W |
| R10 | 1-249-415-11 | s | RES, CARBON 680 5% 1/6W |
| R11 | 1-249-415-11 | s | RES, CARBON 680 5% 1/6W |
| R12 | 1-249-437-11 | s | RES, CARBON 47K 5% 1/6W |
| RB1 | 1-235-005-00 | s | RESISTOR BLOCK, 47KX8 |
| S1 | 1-553-856-00 | s | SWITCH, PUSH |
| X1 | 1-567-817-11 | s | CRYSTAL 29.4912MHz |

CS-21 BOARD, DVR-1000

| Ref. No. or Qty | Part No. | SP | Description |
|--------------------|--------------|----|--------------------------------------|
| 1pc | 1-620-910-11 | o | PC BOARD, CS-21 WITHOUT COMPONENT |
| CN1M | 1-506-473-11 | o | RECEP, 8P, MALE |
| CN2 | 1-562-884-11 | o | CONNECTOR, FPC 4P |
| R1 | 1-249-413-11 | s | RES, CARBON 470 5% 1/6W |
| R2 | 1-249-413-11 | s | RES, CARBON 470 5% 1/6W |

NOTE: Please see pages D-37 and D-38 for the part numbers of capacitors and resistors that are not listed in the parts list.

CS-27 BOARD, DVR-1000

| Ref. No. or Qty | Part No. | SP | Description |
|--------------------|--------------|----|--------------------------------------|
| 1pc | 1-632-588-11 | o | PC BOARD, CS-27 WITHOUT COMPONENT |
| C6 | 1-162-788-11 | s | CAP, CERAMIC 0.003uF 10% 50V |
| C7 | 1-162-788-11 | s | CAP, CERAMIC 0.003uF 10% 50V |
| CN1 | 1-566-480-11 | o | PIN, SOCKET 8P |
| CN2 | 1-566-480-11 | o | PIN, SOCKET 8P |
| IC1 | 8-759-990-84 | s | IC TL084CN |

CT-74 BOARD, DVR-1000

| Ref. No. or Qty | Part No. | SP | Description |
|--------------------|--------------|----|--|
| 1pc | A-6023-041-A | o | COMPLETE PCB, CT-74 (This assembly includes the following parts.) |
| C2 | 1-161-898-11 | s | CAP, CERAMIC 0.47uF 50V |
| C3 | 1-161-898-11 | s | CAP, CERAMIC 0.47uF 50V |
| C5 | 1-130-471-00 | s | CAP, MYLAR 0.001uF 5% 50V |
| C6 | 1-130-471-00 | s | CAP, MYLAR 0.001uF 5% 50V |
| C7 | 1-130-471-00 | s | CAP, MYLAR 0.001uF 5% 50V |
| C10 | 1-130-494-11 | s | CAP, MYLAR 0.082uF 5% 50V |
| C12 | 1-131-347-00 | s | CAP, TANT 1uF 10% 35V |
| C14 | 1-130-494-11 | s | CAP, MYLAR 0.082uF 5% 50V |
| C15 | 1-130-475-00 | s | CAP, MYLAR 0.0022uF 5% 50V |
| CN121M | 1-560-301-00 | o | RECEP, IL 4P, MALE |
| CN122M | 1-560-302-00 | o | RECEP, IL 5P, MALE |
| CN123M | 1-560-304-00 | o | RECEP, IL 8P, MALE |
| D1 | 8-719-911-19 | s | DIODE 1SS119 |
| D2 | 8-719-911-19 | s | DIODE 1SS119 |
| D3 | 8-719-911-19 | s | DIODE 1SS119 |
| D4 | 8-719-100-54 | s | DIODE RD9.1E-B2 |
| D5 | 8-719-911-19 | s | DIODE 1SS119 |
| D6 | 8-719-911-19 | s | DIODE 1SS119 |
| IC1 | 8-759-201-04 | s | IC TC40107BP |
| IC2 | 8-759-040-11 | s | IC MC14011BCP |
| IC3 | 8-759-045-38 | s | IC MC14538BCP |
| IC4 | 8-759-045-84 | s | IC MC14584BCP |
| IC5 | 8-759-133-90 | s | IC uPC339C |
| IC6 | 8-759-340-13 | s | IC HD14013BP |
| IC7 | 8-759-937-59 | s | IC MB3759 |
| L1 | 1-421-329-00 | s | COIL, CHOKE |
| Q1 | 8-729-900-65 | s | TRANSISTOR DTA144ES |
| Q2 | 8-729-900-65 | s | TRANSISTOR DTA144ES |
| Q3 | 8-729-900-65 | s | TRANSISTOR DTA144ES |
| Q4 | 8-729-904-36 | s | TRANSISTOR DTC114YS |
| R1 | 1-249-433-11 | s | RES, CARBON 22K 5% 1/6W |
| R2 | 1-249-441-11 | s | RES, CARBON 100K 5% 1/6W |
| R6 | 1-249-429-11 | s | RES, CARBON 10K 5% 1/6W |
| R7 | 1-249-429-11 | s | RES, CARBON 10K 5% 1/6W |
| R8 | 1-249-429-11 | s | RES, CARBON 10K 5% 1/6W |
| R9 | 1-249-438-11 | s | RES, CARBON 56K 5% 1/6W |
| R10 | 1-249-438-11 | s | RES, CARBON 56K 5% 1/6W |
| R11 | 1-249-438-11 | s | RES, CARBON 56K 5% 1/6W |
| R12 | 1-249-429-11 | s | RES, CARBON 10K 5% 1/6W |
| R13 | 1-249-441-11 | s | RES, CARBON 100K 5% 1/6W |
| R14 | 1-249-427-11 | s | RES, CARBON 6.8K 5% 1/6W |
| R15 | 1-249-414-11 | s | RES, CARBON 560 5% 1/6W |
| R16 | 1-249-438-11 | s | RES, CARBON 56K 5% 1/6W |
| R17 | 1-249-441-11 | s | RES, CARBON 100K 5% 1/6W |
| R22 | 1-249-429-11 | s | RES, CARBON 10K 5% 1/6W |
| R23 | 1-249-423-11 | s | RES, CARBON 3.3K 5% 1/6W |
| R24 | 1-249-431-11 | s | RES, CARBON 15K 5% 1/6W |
| R26 | 1-249-438-11 | s | RES, CARBON 56K 5% 1/6W |
| R36 | 1-249-429-11 | s | RES, CARBON 10K 5% 1/6W |
| RV1 | 1-230-844-11 | s | RES, VAR, METAL 20K |
| RV2 | 1-230-843-11 | s | RES, VAR, METAL 10K |

NOTE: Please see pages D-37 and D-38 for the part numbers of capacitors and resistors that are not listed in the parts list.

DE-17 BOARD, DVR-1000

| Ref. No. or Qty | Part No. | SP | Description |
|--------------------|--------------|----|--------------------------------------|
| 1pc | 1-620-913-11 | o | PC BOARD, DE-17 WITHOUT COMPONENT |

DET-3 BOARD, DVR-1000

| Ref. No. or Qty | Part No. | SP | Description |
|--------------------|--------------|----|--------------------------------------|
| 1pc | 1-618-489-11 | o | PC BOARD, DET-3 WITHOUT COMPONENT |
| 1pc | 3-673-694-00 | o | HOLDER, DME |
| 1pc | 7-685-133-19 | s | SCREW +BTP 2.6X6, TYPE2 N-S |
| C1 | 1-102-074-00 | s | CAP, CERAMIC 0.001uF 10% 50V |
| C2 | 1-124-224-00 | s | CAP, ELECT 47uF 20% 6.3V |
| CN1M | 1-564-016-00 | o | RECEP, 6P, MALE |
| D1 | 8-719-911-19 | s | DIODE 1SS119 |
| DME1 | 8-749-021-10 | s | DME DM-211 |
| IC1 | 8-759-103-93 | s | IC uPC393C |
| R2 | 1-249-425-11 | s | RES, CARBON 4.7K 5% 1/6W |
| R3 | 1-249-425-11 | s | RES, CARBON 4.7K 5% 1/6W |
| RV1 | 1-228-469-00 | s | RES, VAR, CERMET 200 |
| RV2 | 1-228-469-00 | s | RES, VAR, CERMET 200 |

NOTE: Please see pages D-37 and D-38 for the part numbers of capacitors and resistors that are not listed in the parts list.

FC-37 BOARD, DVR-1000

| Ref. No. or Qty | Part No. | SP | Description |
|--------------------|--------------|----|---|
| 1pc | A-6026-071-A | o | MOUNTED PCB, FC-37 (This assembly includes the following parts.) |
| CN210M | 1-506-637-11 | o | CONNECTOR, PS 16P, MALE |
| CN211M | 1-506-637-11 | o | CONNECTOR, PS 16P, MALE |
| CN212M | 1-506-637-11 | o | CONNECTOR, PS 16P, MALE |
| CN213M | 1-506-637-11 | o | CONNECTOR, PS 16P, MALE |
| CN214M | 1-506-636-11 | o | RECEP, PS 14P, MALE |
| CN215M | 1-506-636-11 | o | RECEP, PS 14P, MALE |
| CN216M | 1-506-468-11 | o | RECEP, 3P, MALE |
| CN217M | 1-506-632-11 | o | RECEP, PS 6P, MALE |
| CN218M | 1-506-631-11 | o | RECEP, PS 4P, MALE |
| CN219M | 1-506-632-11 | o | RECEP, PS 6P, MALE |
| CN220M | 1-506-631-11 | o | RECEP, PS 4P, MALE |
| CN221M | 1-506-633-11 | o | RECEP, PS 8P, MALE |
| CN222M | 1-506-636-11 | o | RECEP, PS 14P, MALE |
| CN223M | 1-506-636-11 | o | RECEP, PS 14P, MALE |

FP-24 BOARD, DVR-1000

| Ref. No. or Qty | Part No. | SP | Description |
|--------------------|--------------|----|--------------------------------------|
| 1pc | 1-620-914-11 | o | PC BOARD, FP-24 WITHOUT COMPONENT |
| CN204M | 1-506-633-11 | o | RECEP, PS 8P, MALE |
| CN207F | 1-563-769-11 | s | RECEP, ROUND 8P, FEMALE |

NOTE: Please see pages D-37 and D-38 for the part numbers of capacitors and resistors that are not listed in the parts list.

IF-134 BOARD, DVR-1000

Ref. No. or Qty Part No. SP Description

The following components are included in the RS-422 PANEL (B) assy; A-6032-081-A.

| | | | |
|------|--------------|---|--------------------------|
| 1pc | 7-622-207-05 | s | N 2.6, TYPE 2 |
| 1pc | 7-628-254-30 | s | +PSW, 2.6X10 |
| 1pc | 7-682-648-09 | s | SCREW +PSW 3X8 |
| 1pc | 7-622-207-05 | s | N 2.6, TYPE 2 |
| 1pc | 7-628-254-30 | s | +PSW, 2.6X10 |
| 5pcs | 7-682-648-09 | s | SCREW +PSW 3X8 |
| C2 | 1-124-638-11 | s | CAP, ELECT 22uF 20% 10V |
| C5 | 1-162-216-31 | s | CAP, CERAMIC 51PF 5% 50V |
| C6 | 1-162-216-31 | s | CAP, CERAMIC 51PF 5% 50V |
| C7 | 1-162-216-31 | s | CAP, CERAMIC 51PF 5% 50V |
| C8 | 1-162-216-31 | s | CAP, CERAMIC 51PF 5% 50V |
| C10 | 1-162-216-31 | s | CAP, CERAMIC 51PF 5% 50V |
| C11 | 1-162-216-31 | s | CAP, CERAMIC 51PF 5% 50V |
| C12 | 1-162-216-31 | s | CAP, CERAMIC 51PF 5% 50V |
| C13 | 1-162-216-31 | s | CAP, CERAMIC 51PF 5% 50V |
| CN1M | 1-506-746-11 | s | RECEP, DIN 48P, MALE |
| CN2F | 1-563-323-11 | s | RECEP, D-SUB 9P, FEMALE |
| CN3F | 1-563-323-11 | s | RECEP, D-SUB 9P, FEMALE |
| CN4F | 1-563-323-11 | s | RECEP, D-SUB 9P, FEMALE |
| FB1 | 1-535-178-00 | s | FERRITE BEAD |
| IC1 | 8-759-925-85 | s | IC SN74HC32NS |
| IC2 | 8-759-927-46 | s | IC SN74HC00NS |
| IC3 | 8-759-926-12 | s | IC SN74HC139NS |
| IC4 | 8-759-011-65 | s | IC MC74HC4053F |
| IC5 | 8-759-926-12 | s | IC SN74HC273NS |
| IC6 | 8-759-925-74 | s | IC SN74HC04NS |
| IC7 | 8-759-926-12 | s | IC SN74HC273NS |
| IC8 | 8-759-011-65 | s | IC MC74HC4053F |
| IC9 | 8-759-926-77 | s | IC SN74HC541NS |
| IC10 | 8-759-011-65 | s | IC MC74HC4053F |
| IC11 | 8-759-926-30 | s | IC AM26LS30PC |
| IC12 | 8-759-012-63 | s | IC MC3486P |
| IC13 | 8-759-926-30 | s | IC AM26LS30PC |
| IC14 | 8-759-012-63 | s | IC MC3486P |
| R1 | 1-249-437-11 | s | RES, CARBON 47K 5% 1/6W |
| R2 | 1-249-437-11 | s | RES, CARBON 47K 5% 1/6W |
| R3 | 1-249-417-11 | s | RES, CARBON 1K 5% 1/6W |
| R4 | 1-249-417-11 | s | RES, CARBON 1K 5% 1/6W |
| R5 | 1-249-417-11 | s | RES, CARBON 1K 5% 1/6W |
| R6 | 1-249-417-11 | s | RES, CARBON 1K 5% 1/6W |
| RB1 | 1-235-005-00 | s | RESISTOR BLOCK, 47KX8 |
| RB2 | 1-235-005-00 | s | RESISTOR BLOCK, 47KX8 |

IF-135 BOARD, DVR-1000

Ref. No. or Qty Part No. SP Description

The following components are included in the CN-B PANEL assy; A-6032-070-A.

| | | | |
|------|--------------|---|-------------------------|
| 1pc | 7-622-207-05 | s | N 2.6, TYPE 2 |
| 1pc | 7-628-254-30 | s | +PSW, 2.6X10 |
| 1pc | 7-682-648-09 | s | SCREW +PSW 3X8 |
| 1pc | 7-622-207-05 | s | N 2.6, TYPE 2 |
| 1pc | 7-628-254-30 | s | +PSW, 2.6X10 |
| 1pc | 7-682-648-09 | s | SCREW +PSW 3X8 |
| C1 | 1-124-638-11 | s | CAP, ELECT 22uF 20% 10V |
| CN1M | 1-506-746-11 | s | RECEP, DIN 48P, MALE |
| CN2 | 1-562-815-11 | s | CONNECTOR, GP-IB |
| FB1 | 1-535-178-00 | s | FERRITE BEAD |
| IC1 | 8-759-202-74 | s | IC TC74HC04P |
| IC2 | 8-759-202-89 | s | IC TC74HC139P |
| IC3 | 8-759-112-34 | s | IC uPD7210C |
| IC4 | 8-759-905-03 | s | IC SN75161AN |
| IC5 | 8-759-917-05 | s | IC SN74HC541N |
| IC6 | 8-759-905-02 | s | IC SN75160AN |
| IC7 | 8-759-202-21 | s | IC TC74HC32P |
| R1 | 1-249-429-11 | s | RES, CARBON 10K 5% 1/6W |
| R2 | 1-249-417-11 | s | RES, CARBON 1K 5% 1/6W |
| R3 | 1-249-437-11 | s | RES, CARBON 47K 5% 1/6W |
| R4 | 1-249-429-11 | s | RES, CARBON 10K 5% 1/6W |
| R5 | 1-249-429-11 | s | RES, CARBON 10K 5% 1/6W |
| RB1 | 1-235-005-00 | s | RESISTOR BLOCK, 47KX8 |
| RB2 | 1-235-005-00 | s | RESISTOR BLOCK, 47KX8 |
| RB3 | 1-235-005-00 | s | RESISTOR BLOCK, 47KX8 |

IF-138 BOARD, DVR-1000

| Ref. No. or Qty | Part No. | SP | Description |
|--------------------|--------------|----|---|
| 1pc | A-6021-001-A | o | COMPLETE PCB, IF-138 (This assembly includes the following parts.) |
| 6pcs | 7-622-207-05 | s | N 2.6, TYPE 2 |
| 6pcs | 7-628-254-20 | s | +PSW, 2.6X8 |
| 2pcs | 3-531-576-01 | s | RIVET |
| BT1 | 1-528-218-11 | s | BATTERY, LITHIUM CR2032WT13H |
| C4 | 1-124-638-11 | s | CAP, ELECT 22uF 20% 10V |
| C8 | 1-125-390-11 | s | CAP, CERAMIC 0.047F 5.5V |
| C13 | 1-162-211-31 | s | CAP, CERAMIC 33PF 5% 50V |
| C16 | 1-162-807-11 | s | CAP, CERAMIC 0.12uF 10% 50V |
| CN1 | 1-566-385-11 | s | PIN, CONNECTOR 2P |
| CN2 | 1-566-385-11 | s | PIN, CONNECTOR 2P |
| CN801M | 1-560-731-00 | o | RECEP, 50P, MALE |
| CN802F | 1-563-335-11 | s | RECEP, 48P, FEMALE |
| CN803F | 1-563-335-11 | s | RECEP, 48P, FEMALE |
| CN804F | 1-563-335-11 | s | RECEP, 48P, FEMALE |
| D1 | 8-719-911-19 | s | DIODE 1SS119 |
| D2 | 8-719-101-97 | s | DIODE 1SS97-1 |
| D3 | 8-719-911-19 | s | DIODE 1SS119 |
| D4 | 8-719-911-19 | s | DIODE 1SS119 |
| D6 | 8-719-911-19 | s | DIODE 1SS119 |
| FB1 | 1-535-178-00 | s | FERRITE BEAD |
| FB2 | 1-535-178-00 | s | FERRITE BEAD |
| FB3 | 1-535-178-00 | s | FERRITE BEAD |
| IC1 | 8-759-921-34 | s | IC SN74HC245N |
| IC2 | 8-759-203-48 | s | IC TC74HC573P |
| IC3 | 8-759-921-34 | s | IC SN74HC245N |
| IC4 | 8-759-203-48 | s | IC TC74HC573P |
| IC5 | 8-759-914-41 | s | IC X2212P |
| IC6 | 8-759-914-41 | s | IC X2212P |
| IC7 | 8-759-917-05 | s | IC SN74HC541N |
| IC8 | 8-759-916-79 | s | IC SN74HC273N |
| IC9 | 8-759-112-44 | s | IC uPD7506CT-211 |
| IC10 | 8-759-804-69 | s | IC LC74HC04M |
| JS1 | 1-563-859-11 | s | RECEPTACLE, CONNECTOR 2P |
| Q1 | 8-729-900-45 | s | TRANSISTOR DTC114EF |
| R1 | 1-249-411-11 | s | RES, CARBON 330 5% 1/6W |
| R2 | 1-249-411-11 | s | RES, CARBON 330 5% 1/6W |
| R4 | 1-249-437-11 | s | RES, CARBON 47K 5% 1/6W |
| R5 | 1-249-437-11 | s | RES, CARBON 47K 5% 1/6W |
| R6 | 1-249-437-11 | s | RES, CARBON 47K 5% 1/6W |
| R7 | 1-249-437-11 | s | RES, CARBON 47K 5% 1/6W |
| R10 | 1-249-437-11 | s | RES, CARBON 47K 5% 1/6W |
| R11 | 1-249-429-11 | s | RES, CARBON 10K 5% 1/4W |
| RB1 | 1-235-005-00 | s | RESISTOR BLOCK, 47KX8 |
| RB2 | 1-231-450-00 | s | RESISTOR BLOCK, 3.3KX8 |
| RB3 | 1-235-005-00 | s | RESISTOR BLOCK, 47KX8 |
| RB4 | 1-235-005-00 | s | RESISTOR BLOCK, 47KX8 |
| RB5 | 1-235-005-00 | s | RESISTOR BLOCK, 47KX8 |
| RB6 | 1-235-005-00 | s | RESISTOR BLOCK, 47KX8 |
| RB7 | 1-231-549-11 | s | RESISTOR BLOCK, 47KX4 |
| RB8 | 1-231-549-11 | s | RESISTOR BLOCK, 47KX4 |
| S1 | 1-553-856-00 | s | SWITCH, PUSH |
| X1 | 1-527-990-00 | s | CRYSTAL 32.768KHZ |

IF-221 BOARD, DVR-1000

| Ref. No. or Qty | Part No. | SP | Description |
|---|--------------|----|--------------------------------|
| The following components are included in the PARALLEL I/O PANEL assy; A-6032-080-A. | | | |
| 1pc | X-3715-492-1 | o | PANEL ASSY, PARALLEL I/O |
| 2pcs | 7-622-207-05 | s | N2.6, TYPE 2 |
| 2pcs | 7-628-254-30 | s | SCREW +PS2.6x10 |
| 2pcs | 7-682-648-09 | s | SCREW +PS3x8 |
| C1 | 1-126-153-11 | s | CAP, ELECT 22uF 20% 6.3V |
| C2 | 1-163-038-00 | s | CAP, CHIP CERAMIC 0.1uF 25V |
| C3 | 1-163-117-00 | s | CAP, CHIP CERAMIC 100PF 5% 50V |
| C4 | 1-163-117-00 | s | CAP, CHIP CERAMIC 100PF 5% 50V |
| C5 | 1-163-117-00 | s | CAP, CHIP CERAMIC 100PF 5% 50V |
| C6 | 1-163-117-00 | s | CAP, CHIP CERAMIC 100PF 5% 50V |
| C7 | 1-163-117-00 | s | CAP, CHIP CERAMIC 100PF 5% 50V |
| C8 | 1-163-117-00 | s | CAP, CHIP CERAMIC 100PF 5% 50V |
| C9 | 1-163-117-00 | s | CAP, CHIP CERAMIC 100PF 5% 50V |
| C10 | 1-163-117-00 | s | CAP, CHIP CERAMIC 100PF 5% 50V |
| C11 | 1-163-117-00 | s | CAP, CHIP CERAMIC 100PF 5% 50V |
| C12 | 1-163-117-00 | s | CAP, CHIP CERAMIC 100PF 5% 50V |
| C13 | 1-163-038-00 | s | CAP, CHIP CERAMIC 0.1uF 25V |
| C14 | 1-163-038-00 | s | CAP, CHIP CERAMIC 0.1uF 25V |
| C15 | 1-163-038-00 | s | CAP, CHIP CERAMIC 0.1uF 25V |
| CN1M | 1-506-746-11 | s | RECEP. DIN 48P, MALE |
| CN2 | 1-563-781-00 | s | RECEP. D-SUB 50P |
| FB1 | 1-535-178-00 | s | FERRITE BEAD |
| IC1 | 8-759-926-12 | s | IC SN74HC139NS |
| IC2 | 8-759-926-77 | s | IC SN74HC541NS |
| IC3 | 8-759-925-85 | s | IC SN74HC32NS |
| IC4 | 8-759-925-90 | s | IC SN74HC74NS |
| IC5 | 8-759-938-68 | s | IC CXD1095Q |
| IC6 | 8-759-938-68 | s | IC CXD1095Q |
| IC7 | 8-759-925-80 | s | IC SN74HC14NS |
| IC8 | 8-759-925-80 | s | IC SN74HC14NS |
| Q1 | 8-729-900-53 | s | TRANSISTOR DTC114EK-T-96 |
| Q2 | 8-729-900-53 | s | TRANSISTOR DTC114EK-T-96 |
| Q3 | 8-729-900-53 | s | TRANSISTOR DTC114EK-T-96 |
| Q4 | 8-729-900-53 | s | TRANSISTOR DTC114EK-T-96 |
| Q5 | 8-729-900-53 | s | TRANSISTOR DTC114EK-T-96 |
| Q6 | 8-729-900-53 | s | TRANSISTOR DTC114EK-T-96 |
| Q7 | 8-729-900-53 | s | TRANSISTOR DTC114EK-T-96 |
| Q8 | 8-729-900-53 | s | TRANSISTOR DTC114EK-T-96 |
| Q9 | 8-729-900-53 | s | TRANSISTOR DTC114EK-T-96 |
| Q10 | 8-729-900-53 | s | TRANSISTOR DTC114EK-T-96 |
| Q11 | 8-729-900-53 | s | TRANSISTOR DTC114EK-T-96 |
| Q12 | 8-729-900-53 | s | TRANSISTOR DTC114EK-T-96 |
| Q13 | 8-729-900-53 | s | TRANSISTOR DTC114EK-T-96 |
| Q14 | 8-729-900-53 | s | TRANSISTOR DTC114EK-T-96 |
| Q15 | 8-729-900-53 | s | TRANSISTOR DTC114EK-T-96 |
| Q16 | 8-729-900-53 | s | TRANSISTOR DTC114EK-T-96 |
| Q17 | 8-729-900-53 | s | TRANSISTOR DTC114EK-T-96 |
| Q18 | 8-729-900-53 | s | TRANSISTOR DTC114EK-T-96 |
| Q19 | 8-729-900-53 | s | TRANSISTOR DTC114EK-T-96 |
| Q20 | 8-729-900-53 | s | TRANSISTOR DTC114EK-T-96 |
| Q21 | 8-729-900-53 | s | TRANSISTOR DTC114EK-T-96 |
| Q22 | 8-729-900-53 | s | TRANSISTOR DTC114EK-T-96 |
| Q23 | 8-729-900-53 | s | TRANSISTOR DTC114EK-T-96 |
| Q24 | 8-729-900-53 | s | TRANSISTOR DTC114EK-T-96 |
| Q25 | 8-729-900-53 | s | TRANSISTOR DTC114EK-T-96 |
| Q26 | 8-729-900-53 | s | TRANSISTOR DTC114EK-T-96 |
| Q27 | 8-729-900-53 | s | TRANSISTOR DTC114EK-T-96 |
| Q28 | 8-729-900-53 | s | TRANSISTOR DTC114EK-T-96 |
| Q29 | 8-729-900-53 | s | TRANSISTOR DTC114EK-T-96 |
| Q30 | 8-729-900-53 | s | TRANSISTOR DTC114EK-T-96 |
| Q31 | 8-729-900-53 | s | TRANSISTOR DTC114EK-T-96 |
| Q32 | 8-729-900-53 | s | TRANSISTOR DTC114EK-T-96 |
| Q33 | 8-729-900-53 | s | TRANSISTOR DTC114EK-T-96 |
| Q34 | 8-729-900-53 | s | TRANSISTOR DTC114EK-T-96 |
| Q35 | 8-729-900-53 | s | TRANSISTOR DTC114EK-T-96 |
| Q36 | 8-729-900-53 | s | TRANSISTOR DTC114EK-T-96 |
| Q37 | 8-729-900-53 | s | TRANSISTOR DTC114EK-T-96 |
| Q38 | 8-729-900-53 | s | TRANSISTOR DTC114EK-T-96 |
| R1 | 1-216-089-00 | s | RES, CHIP 47K 5% 1/10W |
| R2 | 1-216-089-00 | s | RES, CHIP 47K 5% 1/10W |

NOTE: Please see pages D-37 and D-38 for the part numbers of capacitors and resistors that are not listed in the parts list.

(IF-221 BOARD, DVR-1000)

| Ref. No. or Qty | Part No. | SP | Description |
|--------------------|--------------|----|-------------------------|
| R3 | 1-216-089-00 | s | RES, CHIP 47K 5% 1/10W |
| R4 | 1-216-089-00 | s | RES, CHIP 47K 5% 1/10W |
| R5 | 1-216-089-00 | s | RES, CHIP 47K 5% 1/10W |
| R6 | 1-216-089-00 | s | RES, CHIP 47K 5% 1/10W |
| R7 | 1-216-089-00 | s | RES, CHIP 47K 5% 1/10W |
| R8 | 1-216-089-00 | s | RES, CHIP 47K 5% 1/10W |
| R9 | 1-216-089-00 | s | RES, CHIP 47K 5% 1/10W |
| R10 | 1-216-089-00 | s | RES, CHIP 47K 5% 1/10W |
| R11 | 1-216-089-00 | s | RES, CHIP 47K 5% 1/10W |
| R12 | 1-216-089-00 | s | RES, CHIP 47K 5% 1/10W |
| R13 | 1-216-089-00 | s | RES, CHIP 47K 5% 1/10W |
| R14 | 1-216-089-00 | s | RES, CHIP 47K 5% 1/10W |
| R15 | 1-216-089-00 | s | RES, CHIP 47K 5% 1/10W |
| R16 | 1-216-089-00 | s | RES, CHIP 47K 5% 1/10W |
| R17 | 1-216-089-00 | s | RES, CHIP 47K 5% 1/10W |
| R18 | 1-216-089-00 | s | RES, CHIP 47K 5% 1/10W |
| R19 | 1-216-065-00 | s | RES, CHIP 4.7K 5% 1/10W |
| R20 | 1-216-065-00 | s | RES, CHIP 4.7K 5% 1/10W |
| R21 | 1-216-065-00 | s | RES, CHIP 4.7K 5% 1/10W |
| R22 | 1-216-065-00 | s | RES, CHIP 4.7K 5% 1/10W |
| R23 | 1-216-065-00 | s | RES, CHIP 4.7K 5% 1/10W |
| R24 | 1-216-065-00 | s | RES, CHIP 4.7K 5% 1/10W |
| R25 | 1-216-065-00 | s | RES, CHIP 4.7K 5% 1/10W |
| R26 | 1-216-065-00 | s | RES, CHIP 4.7K 5% 1/10W |
| R27 | 1-216-089-00 | s | RES, CHIP 47K 5% 1/10W |
| R28 | 1-216-089-00 | s | RES, CHIP 47K 5% 1/10W |
| R29 | 1-216-089-00 | s | RES, CHIP 47K 5% 1/10W |
| R30 | 1-216-089-00 | s | RES, CHIP 47K 5% 1/10W |
| R31 | 1-216-089-00 | s | RES, CHIP 47K 5% 1/10W |
| R32 | 1-216-089-00 | s | RES, CHIP 47K 5% 1/10W |
| R33 | 1-216-089-00 | s | RES, CHIP 47K 5% 1/10W |
| R34 | 1-216-089-00 | s | RES, CHIP 47K 5% 1/10W |
| R35 | 1-216-073-00 | s | RES, CHIP 10K 5% 1/10W |
| R36 | 1-216-073-00 | s | RES, CHIP 10K 5% 1/10W |
| R37 | 1-216-073-00 | s | RES, CHIP 10K 5% 1/10W |
| R38 | 1-216-073-00 | s | RES, CHIP 10K 5% 1/10W |
| R39 | 1-216-073-00 | s | RES, CHIP 10K 5% 1/10W |
| R40 | 1-216-073-00 | s | RES, CHIP 10K 5% 1/10W |
| R41 | 1-216-073-00 | s | RES, CHIP 10K 5% 1/10W |
| R42 | 1-216-073-00 | s | RES, CHIP 10K 5% 1/10W |
| R43 | 1-216-073-00 | s | RES, CHIP 10K 5% 1/10W |
| R44 | 1-216-073-00 | s | RES, CHIP 10K 5% 1/10W |
| R45 | 1-216-073-00 | s | RES, CHIP 10K 5% 1/10W |
| R46 | 1-216-073-00 | s | RES, CHIP 10K 5% 1/10W |
| R47 | 1-216-073-00 | s | RES, CHIP 10K 5% 1/10W |
| R48 | 1-216-073-00 | s | RES, CHIP 10K 5% 1/10W |
| R49 | 1-216-073-00 | s | RES, CHIP 10K 5% 1/10W |
| R50 | 1-216-073-00 | s | RES, CHIP 10K 5% 1/10W |
| R51 | 1-216-073-00 | s | RES, CHIP 10K 5% 1/10W |
| R52 | 1-216-073-00 | s | RES, CHIP 10K 5% 1/10W |
| R53 | 1-216-073-00 | s | RES, CHIP 10K 5% 1/10W |
| R54 | 1-216-073-00 | s | RES, CHIP 10K 5% 1/10W |
| R55 | 1-216-073-00 | s | RES, CHIP 10K 5% 1/10W |
| R56 | 1-216-073-00 | s | RES, CHIP 10K 5% 1/10W |
| R57 | 1-216-073-00 | s | RES, CHIP 10K 5% 1/10W |
| R58 | 1-216-065-00 | s | RES, CHIP 4.7K 5% 1/10W |
| R59 | 1-216-065-00 | s | RES, CHIP 4.7K 5% 1/10W |
| R60 | 1-216-089-00 | s | RES, CHIP 47K 5% 1/10W |
| R61 | 1-216-089-00 | s | RES, CHIP 47K 5% 1/10W |
| R62 | 1-216-073-00 | s | RES, CHIP 10K 5% 1/10W |
| R63 | 1-216-073-00 | s | RES, CHIP 10K 5% 1/10W |
| R64 | 1-216-073-00 | s | RES, CHIP 10K 5% 1/10W |
| R65 | 1-216-073-00 | s | RES, CHIP 10K 5% 1/10W |
| R66 | 1-216-073-00 | s | RES, CHIP 10K 5% 1/10W |
| R67 | 1-216-073-00 | s | RES, CHIP 10K 5% 1/10W |
| R68 | 1-216-073-00 | s | RES, CHIP 10K 5% 1/10W |
| R69 | 1-216-073-00 | s | RES, CHIP 10K 5% 1/10W |
| R70 | 1-216-073-00 | s | RES, CHIP 10K 5% 1/10W |
| R71 | 1-216-073-00 | s | RES, CHIP 10K 5% 1/10W |
| R72 | 1-216-073-00 | s | RES, CHIP 10K 5% 1/10W |
| R73 | 1-216-073-00 | s | RES, CHIP 10K 5% 1/10W |
| R74 | 1-216-073-00 | s | RES, CHIP 10K 5% 1/10W |
| R75 | 1-216-073-00 | s | RES, CHIP 10K 5% 1/10W |
| R76 | 1-216-073-00 | s | RES, CHIP 10K 5% 1/10W |

LE-52 BOARD, DVR-1000

| Ref. No. or Qty | Part No. | SP | Description |
|---|--------------|----|-------------------------|
| The following components are included in the CD BLOCK assy; A-6029-012-E. | | | |
| D1 | 8-719-123-69 | s | DIODE SE310 |
| D2 | 8-719-123-69 | s | DIODE SE310 |
| D3 | 8-719-123-69 | s | DIODE SE310 |
| D4 | 8-719-123-69 | s | DIODE SE310 |
| D5 | 8-719-123-69 | s | DIODE SE310 |
| R1 | 1-247-823-00 | s | RES, CARBON 470 5% 1/6W |
| R2 | 1-247-823-00 | s | RES, CARBON 470 5% 1/6W |
| R3 | 1-247-823-00 | s | RES, CARBON 470 5% 1/6W |
| R4 | 1-247-823-00 | s | RES, CARBON 470 5% 1/6W |
| R5 | 1-247-823-00 | s | RES, CARBON 470 5% 1/6W |

NOTE: Please see pages D-37 and D-38 for the part numbers of capacitors and resistors that are not listed in the parts list.

LE-56 BOARD, DVR-1000

| Ref. No. or Qty | Part No. | SP | Description |
|--------------------|--------------|----|--|
| 1pc | A-6025-105-A | o | COMPLETE PCB, LE-56 (This assembly includes the following parts.) |
| 1pc | 3-674-390-00 | o | HOLDER (B), LED |
| 1pc | 1-620-908-11 | o | PC BOARD, LE-56 WITHOUT COMPONENT |
| CN203M | 1-506-487-11 | o | RECEP, 8P, MALE |
| D1 | 8-719-905-54 | s | DIODE EBG5504S |
| D2 | 8-719-905-54 | s | DIODE EBG5504S |
| D3 | 8-719-905-54 | s | DIODE EBG5504S |
| D4 | 8-719-955-25 | s | DIODE PY5525S |
| R1 | 1-249-408-11 | s | RES, CARBON 180 5% 1/6W |

LO-05 BOARD, DVR-1000

| Ref. No. or Qty | Part No. | SP | Description |
|--------------------|--------------|----|--|
| 1pc | A-6013-082-A | o | COMPLETE PCB, LO-05 (This assembly includes the following parts.) |
| 16pcs | 7-628-254-10 | s | +PSW, 2.6X6 |
| 16pcs | 7-628-253-20 | s | SCREW +PS 2X6 |
| C3 | 1-124-657-00 | s | CAP, ELECT, NONPOLAR, 10uF 20% 50V |
| C6 | 1-124-002-11 | s | CAP, ELECT, NONPOLAR, 1uF 20% 50V |
| C10 | 1-124-657-00 | s | CAP, ELECT, NONPOLAR, 10uF 20% 50V |
| C13 | 1-124-657-00 | s | CAP, ELECT, NONPOLAR, 10uF 20% 50V |
| C16 | 1-124-002-11 | s | CAP, ELECT, NONPOLAR, 1uF 20% 50V |
| C20 | 1-124-657-00 | s | CAP, ELECT, NONPOLAR, 10uF 20% 50V |
| C21 | 1-124-657-00 | s | CAP, ELECT, NONPOLAR, 10uF 20% 50V |
| C24 | 1-124-002-11 | s | CAP, ELECT, NONPOLAR, 1uF 20% 50V |
| C26 | 1-124-657-00 | s | CAP, ELECT, NONPOLAR, 10uF 20% 50V |
| C29 | 1-124-657-00 | s | CAP, ELECT, NONPOLAR, 10uF 20% 50V |
| C32 | 1-124-002-11 | s | CAP, ELECT, NONPOLAR, 1uF 20% 50V |
| C36 | 1-124-657-00 | s | CAP, ELECT, NONPOLAR, 10uF 20% 50V |
| CN910M | 1-506-471-11 | o | CONNECTOR, 6P, MALE |
| CN911M | 1-506-471-11 | o | CONNECTOR, 6P, MALE |
| CN912M | 1-506-632-11 | o | RECEP, PS 6P, MALE |
| CN913M | 1-506-468-31 | o | RECEP, 3P, MALE |
| CN914M | 1-506-470-11 | o | CONNECTOR, 5P, MALE |
| CN915M | 1-506-468-21 | o | RECEP, 3P, MALE |
| CN916M | 1-560-300-00 | o | RECEP, IL 3P, MALE |
| D1 | 8-719-815-55 | s | DIODE 1S1555 |
| D2 | 8-719-815-55 | s | DIODE 1S1555 |
| D3 | 8-719-815-55 | s | DIODE 1S1555 |
| D4 | 8-719-815-55 | s | DIODE 1S1555 |
| D5 | 8-719-815-55 | s | DIODE 1S1555 |
| D6 | 8-719-815-55 | s | DIODE 1S1555 |
| D7 | 8-719-815-55 | s | DIODE 1S1555 |
| D8 | 8-719-815-55 | s | DIODE 1S1555 |
| D9 | 8-719-815-55 | s | DIODE 1S1555 |
| D10 | 8-719-815-55 | s | DIODE 1S1555 |
| D11 | 8-719-815-55 | s | DIODE 1S1555 |
| IC1 | 8-759-745-60 | s | IC NJM4560D |
| IC2 | 8-759-745-60 | s | IC NJM4560D |
| IC3 | 8-759-745-60 | s | IC NJM4560D |
| IC4 | 8-759-745-60 | s | IC NJM4560D |
| L1 | 1-421-370-00 | s | COIL, CHOKE |
| L2 | 1-421-370-00 | s | COIL, CHOKE |
| L3 | 1-421-370-00 | s | COIL, CHOKE |
| L4 | 1-421-370-00 | s | COIL, CHOKE |
| L5 | 1-421-370-00 | s | COIL, CHOKE |
| Q1 | 8-729-307-28 | s | TRANSISTOR 2SA872A-E |
| Q2 | 8-729-307-28 | s | TRANSISTOR 2SA872A-E |
| Q3 | 8-729-307-28 | s | TRANSISTOR 2SA872A-E |
| Q4 | 8-729-307-58 | s | TRANSISTOR 2SC1775A |
| Q5 | 8-729-307-58 | s | TRANSISTOR 2SC1775A |
| Q6 | 8-729-307-58 | s | TRANSISTOR 2SC1775A |
| Q7 | 8-729-316-22 | s | TRANSISTOR 2SC1162-C |
| Q8 | 8-729-371-53 | s | TRANSISTOR 2SA715 |
| Q9 | 1-807-103-11 | s | TRANSISTOR DTC114YS |
| Q10 | 8-729-307-28 | s | TRANSISTOR 2SA872A-E |
| Q11 | 8-729-307-28 | s | TRANSISTOR 2SA872A-E |
| Q12 | 8-729-307-28 | s | TRANSISTOR 2SA872A-E |
| Q13 | 8-729-307-58 | s | TRANSISTOR 2SC1775A |
| Q14 | 8-729-307-58 | s | TRANSISTOR 2SC1775A |
| Q15 | 8-729-307-58 | s | TRANSISTOR 2SC1775A |
| Q16 | 8-729-316-22 | s | TRANSISTOR 2SC1162-C |
| Q17 | 8-729-371-53 | s | TRANSISTOR 2SA715 |
| Q18 | 8-729-900-63 | s | TRANSISTOR DTA124ES |
| Q19 | 8-729-900-36 | s | TRANSISTOR DTC124ES |
| Q20 | 8-729-900-63 | s | TRANSISTOR DTA124ES |
| Q21 | 1-807-103-11 | s | TRANSISTOR DTC114YS |
| Q22 | 8-729-307-28 | s | TRANSISTOR 2SA872A-E |
| Q23 | 8-729-307-28 | s | TRANSISTOR 2SA872A-E |
| Q24 | 8-729-307-28 | s | TRANSISTOR 2SA872A-E |
| Q25 | 8-729-307-58 | s | TRANSISTOR 2SC1775A |
| Q26 | 8-729-307-58 | s | TRANSISTOR 2SC1775A |
| Q27 | 8-729-307-58 | s | TRANSISTOR 2SC1775A |
| Q28 | 8-729-316-22 | s | TRANSISTOR 2SC1162-C |
| Q29 | 8-729-371-53 | s | TRANSISTOR 2SA715 |

NOTE: Please see pages D-37 and D-38 for the part numbers of capacitors and resistors that are not listed in the parts list.

(LO-05 BOARD, DVR-1000)

| Ref. No. or Qty | Part No. | SP | Description |
|--------------------|--------------|----|---------------------------|
| Q30 | 8-729-307-28 | s | TRANSISTOR 2SA872A-E |
| Q31 | 8-729-307-28 | s | TRANSISTOR 2SA872A-E |
| Q32 | 8-729-307-28 | s | TRANSISTOR 2SA872A-E |
| Q33 | 8-729-307-58 | s | TRANSISTOR 2SC1775A |
| Q34 | 8-729-307-58 | s | TRANSISTOR 2SC1775A |
| Q35 | 8-729-307-58 | s | TRANSISTOR 2SC1775A |
| Q36 | 8-729-316-22 | s | TRANSISTOR 2SC1162-C |
| Q37 | 8-729-371-53 | s | TRANSISTOR 2SA715 |
| Q38 | 1-807-103-11 | s | TRANSISTOR DTC114YS |
| Q39 | 1-807-103-11 | s | TRANSISTOR DTC114YS |
| R1 | 1-249-411-11 | s | RES. CARBON 330 5% 1/6W |
| R2 | 1-249-423-11 | s | RES. CARBON 3.3K 5% 1/6W |
| R4 | 1-249-421-11 | s | RES. CARBON 2.2K 5% 1/6W |
| R6 | 1-249-449-11 | s | RES. CARBON 1.5 5% 1/4W |
| R7 | 1-249-449-11 | s | RES. CARBON 1.5 5% 1/4W |
| R8 | 1-249-423-11 | s | RES. CARBON 3.3K 5% 1/6W |
| R9 | 1-249-411-11 | s | RES. CARBON 330 5% 1/6W |
| R12 | 1-249-437-11 | s | RES. CARBON 47K 5% 1/6W |
| R14 | 1-249-411-11 | s | RES. CARBON 330 5% 1/6W |
| R15 | 1-249-423-11 | s | RES. CARBON 3.3K 5% 1/6W |
| R17 | 1-249-421-11 | s | RES. CARBON 2.2K 5% 1/6W |
| R19 | 1-249-449-11 | s | RES. CARBON 1.5 5% 1/4W |
| R20 | 1-249-449-11 | s | RES. CARBON 1.5 5% 1/4W |
| R21 | 1-249-423-11 | s | RES. CARBON 3.3K 5% 1/6W |
| R22 | 1-249-411-11 | s | RES. CARBON 330 5% 1/6W |
| R25 | 1-249-437-11 | s | RES. CARBON 47K 5% 1/6W |
| R26 | 1-249-433-11 | s | RES. CARBON 22K 5% 1/6W |
| R28 | 1-249-411-11 | s | RES. CARBON 330 5% 1/6W |
| R29 | 1-249-423-11 | s | RES. CARBON 3.3K 5% 1/6W |
| R30 | 1-249-437-11 | s | RES. CARBON 47K 5% 1/6W |
| R31 | 1-249-421-11 | s | RES. CARBON 2.2K 5% 1/6W |
| R33 | 1-249-449-11 | s | RES. CARBON 1.5 5% 1/4W |
| R34 | 1-249-449-11 | s | RES. CARBON 1.5 5% 1/4W |
| R35 | 1-249-423-11 | s | RES. CARBON 3.3K 5% 1/6W |
| R36 | 1-249-411-11 | s | RES. CARBON 330 5% 1/6W |
| R39 | 1-249-437-11 | s | RES. CARBON 47K 5% 1/6W |
| R40 | 1-249-411-11 | s | RES. CARBON 330 5% 1/6W |
| R41 | 1-249-423-11 | s | RES. CARBON 3.3K 5% 1/6W |
| R42 | 1-249-437-11 | s | RES. CARBON 47K 5% 1/6W |
| R43 | 1-249-421-11 | s | RES. CARBON 2.2K 5% 1/6W |
| R45 | 1-249-449-11 | s | RES. CARBON 1.5 5% 1/4W |
| R46 | 1-249-449-11 | s | RES. CARBON 1.5 5% 1/4W |
| R47 | 1-249-423-11 | s | RES. CARBON 3.3K 5% 1/6W |
| R48 | 1-249-411-11 | s | RES. CARBON 330 5% 1/6W |
| R51 | 1-249-437-11 | s | RES. CARBON 47K 5% 1/6W |
| RV1 | 1-230-843-11 | s | RES. VAR. METAL 10K |
| RV2 | 1-230-843-11 | s | RES. VAR. METAL 10K |
| RV3 | 1-230-843-11 | s | RES. VAR. METAL 10K |
| RV4 | 1-230-843-11 | s | RES. VAR. METAL 10K |
| RY1 | 1-515-683-11 | s | RELAY |
| RY2 | 1-515-683-11 | s | RELAY |
| RY3 | 1-515-683-11 | s | RELAY |
| RY4 | 1-515-683-11 | s | RELAY |
| T1 | 1-427-518-00 | s | TRANSFORMER, AUDIO OUTPUT |
| T2 | 1-427-518-00 | s | TRANSFORMER, AUDIO OUTPUT |
| T3 | 1-427-518-00 | s | TRANSFORMER, AUDIO OUTPUT |
| T4 | 1-427-518-00 | s | TRANSFORMER, AUDIO OUTPUT |

MB-133 BOARD, DVR-1000

| Ref. No. or Qty | Part No. | SP | Description |
|--------------------|--------------|----|---|
| 1pc | A-6025-108-A | o | COMPLETE PCB, MB-133 (This assembly includes the following parts.) |
| 26pcs | 7-628-254-20 | s | +PSW, 2.6X3 |
| 26pcs | 7-622-207-05 | s | N 2.6, TYPE 2 |
| CN701M | 1-506-637-11 | o | CONNECTOR, PS 15P, MALE |
| CN702M | 1-506-467-11 | o | CONNECTOR, 2P, MALE |
| CN703M | 1-506-473-11 | o | RECEP, 8P, MALE |
| CN704M | 1-506-628-11 | o | RECEP, PS 26P, MALE |
| CN705F | 1-563-337-11 | s | RECEP, 96P, FEMALE |
| CN706F | 1-563-335-11 | s | RECEP, 48P, FEMALE |
| CN707M | 1-506-618-11 | o | RECEP, PS 6P, MALE |
| CN708M | 1-506-475-11 | o | RECEP, 10P, MALE |
| CN709M | 1-506-484-11 | o | RECEP, 5P, MALE |
| CN710M | 1-506-482-11 | o | RECEP, 3P, MALE |
| CN711M | 1-506-635-11 | o | RECEP, PS 12P, MALE |
| CN712M | 1-506-622-11 | o | RECEP, PS 14P, MALE |
| CN713F | 1-563-337-11 | s | RECEP, 96P, FEMALE |
| CN714F | 1-563-335-11 | s | RECEP, 48P, FEMALE |
| CN715F | 1-563-335-11 | s | RECEP, 48P, FEMALE |
| CN716M | 1-506-621-11 | o | RECEP, PS 12P, MALE |
| CN717M | 1-506-485-11 | o | RECEP, 6P, MALE |
| CN718F | 1-563-337-11 | s | RECEP, 96P, FEMALE |
| CN719F | 1-563-335-11 | s | RECEP, 48P, FEMALE |
| CN720F | 1-563-337-11 | s | RECEP, 96P, FEMALE |
| CN721F | 1-563-335-11 | s | RECEP, 48P, FEMALE |
| CN722F | 1-563-337-11 | s | RECEP, 96P, FEMALE |
| CN723F | 1-563-335-11 | s | RECEP, 48P, FEMALE |
| CN724F | 1-563-337-11 | s | RECEP, 96P, FEMALE |
| CN725F | 1-563-335-11 | s | RECEP, 48P, FEMALE |
| CN726M | 1-506-485-21 | o | RECEP, 6P, MALE |
| CN727M | 1-560-731-00 | o | RECEP, 50P, MALE |
| CN728M | 1-560-753-00 | o | RECEP, 5P, MALE |
| CN729M | 1-506-494-11 | o | RECEP, 15P, MALE |
| CN730M | 1-506-632-11 | o | RECEP, PS 6P, MALE |
| CN731M | 1-506-486-11 | o | RECEP, 7P, MALE |
| CN732M | 1-506-617-11 | o | RECEP, PS 4P, MALE |

NOTE: Please see pages D-37 and D-38 for the part numbers of capacitors and resistors that are not listed in the parts list.

MB-137 BOARD, DVR-1000

| Ref. No. or Qty | Part No. | SP | Description |
|---|--------------|----|---|
| 1pc | A-6023-044-A | o | COMPLETE PCB, MB-137 (This assembly includes the following parts.) |
| 1pc | 1-564-831-11 | o | TERMINAL |
| 4pcs | 7-622-207-05 | s | N 2.6, TYPE 2 |
| 4pcs | 7-628-254-20 | s | +PSW, 2.6X8 |
| CN105F (to PS-138 board) | | | |
| | 1-563-120-11 | o | HOUSING, PS 12P |
| | 1-563-115-11 | o | CONTACT, FEMALE AWG24-28 |
| CN131F 1-563-335-11 s RECEP, 48P, FEMALE | | | |
| CN132F 1-563-337-11 s RECEP, 96P, FEMALE | | | |
| CN133F (to MB-137 board) | | | |
| | 1-563-119-11 | o | HOUSING, PS 10P |
| | 1-563-115-11 | o | CONTACT, FEMALE AWG24-28 |
| CN133M 1-506-634-11 o RECEP, PS 10P, MALE | | | |
| CN134F (to MB-137 board) | | | |
| | 1-563-117-11 | o | HOUSING, PS 6P |
| | 1-563-115-11 | o | CONTACT, FEMALE AWG24-28 |
| CN134M 1-506-632-11 o RECEP, PS 6P, MALE | | | |
| CN135F (to MB-137 board) | | | |
| | 1-562-147-11 | o | HOUSING, 2P |
| | 1-563-088-11 | o | CONTACT, FEMALE AWG24-30 |
| CN135M 1-506-467-11 o RECEP, 2P, MALE | | | |
| CN211F (to FC-37 board) | | | |
| | 1-563-122-11 | o | HOUSING, PS 16P |
| | 1-563-115-11 | o | CONTACT, FEMALE AWG24-28 |
| CN213F (to FC-37 board) | | | |
| | 1-563-122-11 | o | HOUSING, PS 16P |
| | 1-563-115-11 | o | CONTACT, FEMALE AWG24-28 |
| CN215F (to FC-37 board) | | | |
| | 1-563-121-11 | o | HOUSING, PS 14P |
| | 1-563-115-11 | o | CONTACT, FEMALE AWG24-28 |
| CN217F (to FC-37 board) | | | |
| | 1-563-117-11 | o | HOUSING, PS 6P |
| | 1-563-115-11 | o | CONTACT, FEMALE AWG24-28 |
| CN221F (to FC-37 board) | | | |
| | 1-563-118-11 | o | HOUSING, PS 8P |
| | 1-563-115-11 | o | CONTACT, FEMALE AWG24-28 |
| CN223F (to FC-37 board) | | | |
| | 1-563-121-11 | o | HOUSING, PS 14P |
| | 1-563-115-11 | o | CONTACT, FEMALE AWG24-28 |
| CN930F (to PD-36 board) | | | |
| | 1-562-148-11 | o | HOUSING, 3P |
| | 1-563-088-11 | o | CONTACT, FEMALE AWG24-30 |

MD-43 BOARD, DVR-1000

| Ref. No. or Qty | Part No. | SP | Description |
|---|--------------|----|--|
| 1pc | A-6023-042-A | o | COMPLETE PCB, MD-43 (This assembly includes the following parts.) |
| 1pc | 7-622-207-05 | s | N 2.6, TYPE 2 |
| 1pc | 7-628-254-10 | s | +PSW, 2.6X6 |
| 1pc | 7-628-254-30 | s | +PSW, 2.6X10 |
| 1pc | 7-628-254-20 | s | +PSW, 2.6X8 |
| 1pc | 7-682-648-09 | s | SCREW +PSW 3X8 |
| 19pcs 2-832-007-00 s BUSHING (K), INSULATING | | | |
| 27pcs 7-628-254-20 s +PSW, 2.6X8 | | | |
| 3pcs 7-622-207-05 s N 2.6, TYPE 2 | | | |
| 5pcs 7-628-254-10 s +PSW, 2.6X6 | | | |
| 3pcs 7-628-254-30 s +PSW, 2.6X10 | | | |
| 5pcs 7-682-648-09 s SCREW +PSW 3X8 | | | |
| C5 1-124-247-00 s CAP, ELECT 10uF 20% 35V | | | |
| C6 1-124-247-00 s CAP, ELECT 10uF 20% 35V | | | |
| C7 1-124-247-00 s CAP, ELECT 10uF 20% 35V | | | |
| C8 1-130-483-00 s CAP, MYLAR 0.01uF 5% 50V | | | |
| C101 1-130-478-00 s CAP, MYLAR 0.0039uF 5% 50V | | | |
| C102 1-130-478-00 s CAP, MYLAR 0.0039uF 5% 50V | | | |
| C103 1-162-810-11 s CAP, CERAMIC 0.22uF 10% 50V | | | |
| C104 1-126-147-11 s CAP, ELECT 120uF 20% 63V | | | |
| C105 1-126-112-11 s CAP, ELECT 5.6uF 20% 100V | | | |
| C106 1-126-111-11 s CAP, ELECT 3.3uF 20% 100V | | | |
| C107 1-126-147-11 s CAP, ELECT 120uF 20% 63V | | | |
| C108 1-130-487-00 s CAP, MYLAR 0.022uF 5% 50V | | | |
| C109 1-130-487-00 s CAP, MYLAR 0.022uF 5% 50V | | | |
| C110 1-130-487-00 s CAP, MYLAR 0.022uF 5% 50V | | | |
| C201 1-130-478-00 s CAP, MYLAR 0.0039uF 5% 50V | | | |
| C202 1-162-810-11 s CAP, CERAMIC 0.22uF 10% 50V | | | |
| C203 1-130-483-00 s CAP, MYLAR 0.01uF 5% 50V | | | |
| C204 1-126-147-11 s CAP, ELECT 120uF 20% 63V | | | |
| C205 1-126-112-11 s CAP, ELECT 5.6uF 20% 100V | | | |
| C206 1-126-111-11 s CAP, ELECT 3.3uF 20% 100V | | | |
| C207 1-126-147-11 s CAP, ELECT 120uF 20% 63V | | | |
| C213 1-130-487-00 s CAP, MYLAR 0.022uF 5% 50V | | | |
| C214 1-124-969-11 s ELECT 4.7uF 20% 50V | | | |
| C215 1-124-969-11 s ELECT 4.7uF 20% 50V | | | |
| C216 1-124-969-11 s ELECT 4.7uF 20% 50V | | | |
| C301 1-130-478-00 s CAP, MYLAR 0.0039uF 5% 50V | | | |
| C302 1-162-810-11 s CAP, CERAMIC 0.22uF 10% 50V | | | |
| C303 1-130-483-00 s CAP, MYLAR 0.01uF 5% 50V | | | |
| C304 1-126-147-11 s CAP, ELECT 120uF 20% 63V | | | |
| C305 1-126-112-11 s CAP, ELECT 5.6uF 20% 100V | | | |
| C306 1-126-111-11 s CAP, ELECT 3.3uF 20% 100V | | | |
| C307 1-126-147-11 s CAP, ELECT 120uF 20% 63V | | | |
| C313 1-130-487-00 s CAP, MYLAR 0.022uF 5% 50V | | | |
| C314 1-249-969-11 s ELECT 4.7uF 20% 50V | | | |
| C315 1-249-969-11 s ELECT 4.7uF 20% 50V | | | |
| C316 1-249-969-11 s ELECT 4.7uF 20% 50V | | | |
| C403 1-102-106-00 s CAP, CERAMIC 100PF 10% 50V | | | |
| C404 1-130-487-00 s CAP, MYLAR 0.022uF 5% 50V | | | |
| C503 1-124-638-11 s CAP, ELECT 22uF 20% 10V | | | |
| C504 1-124-927-11 s CAP, ELECT 4.7uF 20% 50V | | | |
| C505 1-124-927-11 s CAP, ELECT 4.7uF 20% 50V | | | |
| C510 1-130-483-00 s CAP, MYLAR 0.01uF 5% 50V | | | |
| C511 1-130-487-00 s CAP, MYLAR 0.022uF 5% 50V | | | |
| C512 1-130-487-00 s CAP, MYLAR 0.022uF 5% 50V | | | |
| C513 1-130-487-00 s CAP, MYLAR 0.022uF 5% 50V | | | |
| C514 1-102-106-00 s CAP, CERAMIC 100PF 10% 50V | | | |
| C515 1-102-106-00 s CAP, CERAMIC 100PF 10% 50V | | | |
| C516 1-102-106-00 s CAP, CERAMIC 100PF 10% 50V | | | |
| CN131M 1-506-746-11 s RECEP, DIN 48P, MALE | | | |
| CN132M 1-506-748-11 s RECEP, DIN 96P, MALE | | | |
| CP101 1-235-966-11 s CR BLOCK, C=2200PF R=20 | | | |
| CP201 1-235-966-11 s CR BLOCK, C=2200PF R=20 | | | |
| CP301 1-235-966-11 s CR BLOCK, C=2200PF R=20 | | | |
| D1 8-719-933-30 s DIODE DA210S | | | |
| D101 8-719-100-86 s DIODE RD22E-B2 | | | |
| D102 8-719-900-95 s DIODE ERB44-02 | | | |
| D103 8-719-911-19 s DIODE 1SS119 | | | |
| D104 8-719-911-19 s DIODE 1SS119 | | | |

NOTE: Please see pages D-37 and D-38 for the part numbers of capacitors and resistors that are not listed in the parts list.

(MD-43 BOARD, DVR-1000)

| Ref. No. or Qty | Part No. | SP | Description |
|--------------------|--------------|----|-------------------------|
| D105 | 8-719-911-19 | s | DIODE 1SS119 |
| D106 | 8-719-911-06 | s | DIODE 1SS106 |
| D201 | 8-719-900-95 | s | DIODE ERB44-02 |
| D202 | 1-806-660-11 | s | DIODE ESAB85-009 |
| D203 | 8-719-912-51 | s | DIODE ESAC25-04C |
| D204 | 8-719-912-51 | s | DIODE ESAC25-04C |
| D205 | 8-719-912-51 | s | DIODE ESAC25-04C |
| D206 | 8-719-911-19 | s | DIODE 1SS119 |
| D207 | 8-719-911-19 | s | DIODE 1SS119 |
| D208 | 8-719-911-19 | s | DIODE 1SS119 |
| D301 | 8-719-900-95 | s | DIODE ERB44-02 |
| D302 | 1-806-660-11 | s | DIODE ESAB85-009 |
| D303 | 8-719-912-51 | s | DIODE ESAC25-04C |
| D304 | 8-719-912-51 | s | DIODE ESAC25-04C |
| D305 | 8-719-912-51 | s | DIODE ESAC25-04C |
| D306 | 8-719-911-19 | s | DIODE 1SS119 |
| D307 | 8-719-911-19 | s | DIODE 1SS119 |
| D308 | 8-719-911-19 | s | DIODE 1SS119 |
| D501 | 8-719-911-19 | s | DIODE 1SS119 |
| D502 | 1-807-200-11 | s | DIODE S5277B |
| D503 | 1-807-200-11 | s | DIODE S5277B |
| D505 | 8-719-911-19 | s | DIODE 1SS119 |
| D506 | 8-719-911-19 | s | DIODE 1SS119 |
| D507 | 8-719-911-19 | s | DIODE 1SS119 |
| D508 | 8-719-911-19 | s | DIODE 1SS119 |
| IC1 | 8-759-700-11 | s | IC NJM78M05A |
| IC3 | 8-759-133-90 | s | IC μ PC339C |
| IC101 | 8-741-132-00 | s | IC BX1320 |
| IC102 | 8-741-128-10 | s | IC BX1281 |
| IC103 | 8-741-128-10 | s | IC BX1281 |
| IC104 | 8-759-208-45 | s | IC MP6901 |
| IC201 | 8-741-132-10 | s | IC BX1321 |
| IC202 | 8-759-939-48 | s | IC FT5761M |
| IC203 | 8-759-250-20 | s | IC TC5020BP |
| IC301 | 8-741-132-10 | s | IC BX1321 |
| IC302 | 8-759-939-48 | s | IC FT5761M |
| IC303 | 8-759-250-20 | s | IC TC5020BP |
| IC401 | 8-759-135-80 | s | IC μ PC358C |
| IC501 | 8-759-925-26 | s | IC CX23026 |
| IC502 | 8-759-000-89 | s | IC MC14556BCP |
| IC503 | 8-759-205-56 | s | IC TA7267P |
| IC504 | 8-759-208-51 | s | IC TA7257P |
| IC505 | 8-759-135-80 | s | IC μ PC358C |
| IC506 | 8-759-208-51 | s | IC TA7257P |
| IC507 | 8-759-208-51 | s | IC TA7257P |
| L1 | 1-421-329-00 | s | COIL, CHOKE |
| L2 | 1-421-329-00 | s | COIL, CHOKE |
| L3 | 1-421-329-00 | s | COIL, CHOKE |
| L101 | 1-410-316-11 | s | INDUCTOR, 1 μ H 20% |
| L102 | 1-410-316-11 | s | INDUCTOR, 1 μ H 20% |
| L103 | 1-421-329-00 | s | COIL, CHOKE |
| L104 | 1-413-090-00 | s | COIL, SN |
| L105 | 1-421-329-00 | s | COIL, CHOKE |
| L201 | 1-410-316-11 | s | INDUCTOR, 1 μ H 20% |
| L202 | 1-421-329-00 | s | COIL, CHOKE |
| L203 | 1-413-090-00 | s | COIL, SN |
| L204 | 1-421-329-00 | s | COIL, CHOKE |
| L301 | 1-410-316-11 | s | INDUCTOR, 1 μ H 20% |
| L302 | 1-421-329-00 | s | COIL, CHOKE |
| L303 | 1-413-090-00 | s | COIL, SN |
| L304 | 1-421-329-00 | s | COIL, CHOKE |
| Q1 | 8-729-900-36 | s | TRANSISTOR DTC124ES |
| Q2 | 8-729-900-36 | s | TRANSISTOR DTC124ES |
| Q3 | 8-729-374-02 | s | TRANSISTOR 2SB740 |
| Q101 | 8-729-304-36 | s | TRANSISTOR 2SK428 |
| Q102 | 8-729-304-35 | s | TRANSISTOR 2SJ122 |
| Q103 | 8-729-900-36 | s | TRANSISTOR DTC124ES |
| Q104 | 8-729-900-36 | s | TRANSISTOR DTC124ES |
| Q105 | 8-729-900-36 | s | TRANSISTOR DTC124ES |
| Q201 | 8-729-904-38 | s | TRANSISTOR 2SD1118 |
| Q202 | 8-729-904-38 | s | TRANSISTOR 2SD1118 |

(MD-43 BOARD, DVR-1000)

| Ref. No. or Qty | Part No. | SP | Description |
|--------------------|--------------|----|-----------------------------|
| Q203 | 8-729-904-38 | s | TRANSISTOR 2SD1118 |
| Q204 | 8-729-304-35 | s | TRANSISTOR 2SJ122 |
| Q205 | 8-729-900-36 | s | TRANSISTOR DTC124ES |
| Q206 | 8-729-900-36 | s | TRANSISTOR DTC124ES |
| Q207 | 8-729-900-36 | s | TRANSISTOR DTC124ES |
| Q301 | 8-729-904-38 | s | TRANSISTOR 2SD1118 |
| Q302 | 8-729-904-38 | s | TRANSISTOR 2SD1118 |
| Q303 | 8-729-904-38 | s | TRANSISTOR 2SD1118 |
| Q304 | 8-729-304-35 | s | TRANSISTOR 2SJ122 |
| Q305 | 8-729-900-36 | s | TRANSISTOR DTC124ES |
| Q306 | 8-729-900-36 | s | TRANSISTOR DTC124ES |
| Q307 | 8-729-900-36 | s | TRANSISTOR DTC124ES |
| Q401 | 8-729-804-91 | s | TRANSISTOR 2SD1682-S |
| Q402 | 8-729-804-86 | s | TRANSISTOR 2SB1142-S |
| Q403 | 8-729-100-12 | s | TRANSISTOR 2SC2001-L |
| Q501 | 8-729-900-36 | s | TRANSISTOR DTC124ES |
| Q502 | 8-729-804-86 | s | TRANSISTOR 2SB1142-S |
| Q503 | 8-729-900-36 | s | TRANSISTOR DTC124ES |
| Q504 | 8-729-900-36 | s | TRANSISTOR DTC124ES |
| Q505 | 8-729-384-46 | s | TRANSISTOR 2SA844-C |
| Q506 | 8-729-384-46 | s | TRANSISTOR 2SA844-C |
| Q507 | 8-729-199-82 | s | TRANSISTOR 2SD998 |
| Q508 | 8-729-199-82 | s | TRANSISTOR 2SD998 |
| Q510 | 8-729-224-02 | s | TRANSISTOR 2SC2240-BL |
| Q511 | 8-729-224-02 | s | TRANSISTOR 2SC2240-BL |
| Q513 | 8-729-374-02 | s | TRANSISTOR 2SB740 |
| R1 | 1-215-485-00 | s | RES, METAL 470K 1% 1/6W |
| R2 | 1-249-430-11 | s | RES, CARBON 12K 5% 1/6W |
| R3 | 1-249-417-11 | s | RES, CARBON 1K 5% 1/6W |
| R4 | 1-249-429-11 | s | RES, CARBON 10K 5% 1/6W |
| R10 | 1-249-417-11 | s | RES, CARBON 1K 5% 1/6W |
| R11 | 1-249-430-11 | s | RES, CARBON 12K 5% 1/6W |
| R12 | 1-249-417-11 | s | RES, CARBON 1K 5% 1/6W |
| R13 | 1-247-849-00 | s | RES, CARBON 5.6K 5% 1/6W |
| R14 | 1-249-430-11 | s | RES, CARBON 12K 5% 1/6W |
| R15 | 1-249-429-11 | s | RES, CARBON 10K 5% 1/6W |
| R18 | 1-249-421-11 | s | RES, CARBON 2.2K 5% 1/6W |
| R19 | 1-249-427-11 | s | RES, CARBON 6.8K 5% 1/6W |
| R102 | 1-249-441-11 | s | RES, CARBON 100K 5% 1/6W |
| R103 | 1-249-403-11 | s | RES, CARBON 68 5% 1/4W |
| R104 | 1-249-434-11 | s | RES, CARBON 27K 5% 1/6W |
| R105 | 1-249-407-11 | s | RES, CARBON 150 5% 1/6W |
| R106 | 1-249-416-11 | s | RES, CARBON 820K 5% 1/6W |
| R109 | 1-249-397-11 | s | RES, CARBON 22 5% 1/6W |
| R110 | 1-249-397-11 | s | RES, CARBON 22 5% 1/6W |
| R111 | 1-249-437-11 | s | RES, CARBON 47K 5% 1/6W |
| R112 | 1-249-431-11 | s | RES, CARBON 15K 5% 1/6W |
| R113 | 1-247-731-11 | s | RES, CARBON 22 5% 1/2W |
| R114 | 1-247-731-11 | s | RES, CARBON 22 5% 1/2W |
| R115 | 1-217-611-00 | s | RES, METAL 0.1 10% 2W |
| R116 | 1-249-424-11 | s | RES, CARBON 3.9K 5% 1/6W |
| R117 | 1-249-429-11 | s | RES, CARBON 10K 5% 1/6W |
| R118 | 1-249-429-11 | s | RES, CARBON 10K 5% 1/6W |
| R119 | 1-249-424-11 | s | RES, CARBON 3.9K 5% 1/6W |
| R120 | 1-249-429-11 | s | RES, CARBON 10K 5% 1/6W |
| R121 | 1-249-429-11 | s | RES, CARBON 10K 5% 1/6W |
| R122 | 1-249-424-11 | s | RES, CARBON 3.9K 5% 1/6W |
| R123 | 1-249-429-11 | s | RES, CARBON 10K 5% 1/6W |
| R129 | 1-249-417-11 | s | RES, CARBON 1K 5% 1/6W |
| R130 | 1-249-411-11 | s | RES, CARBON 330 5% 1/6W |
| R202 | 1-249-431-11 | s | RES, CARBON 15K 5% 1/4W |
| R203 | 1-249-417-11 | s | RES, CARBON 1K 5% 1/4W |
| R204 | 1-249-749-00 | s | RES, CARBON 2.2M 5% 1/4W |
| R205 | 1-249-437-11 | s | RES, CARBON 47K 5% 1/4W |
| R206 | 1-216-381-11 | s | RES, METAL OXIDE 0.22 5% 3W |
| R207 | 1-247-731-11 | s | RES, CARBON 22 5% 1/2W |
| R208 | 1-247-731-11 | s | RES, CARBON 22 5% 1/2W |
| R212 | 1-249-423-11 | s | RES, CARBON 3.3K 5% 1/4W |
| R213 | 1-249-423-11 | s | RES, CARBON 3.3K 5% 1/4W |
| R214 | 1-249-423-11 | s | RES, CARBON 3.3K 5% 1/4W |

NOTE: Please see pages D-37 and D-38 for the part numbers of capacitors and resistors that are not listed in the parts list.

(MD-43 BOARD, DVR-1000)

| Ref. No. or Qty | Part No. | SP | Description |
|--------------------|--------------|----|-----------------------------|
| R215 | 1-249-417-11 | s | RES, CARBON 1K 5% 1/4W |
| R302 | 1-249-431-11 | s | RES, CARBON 15K 5% 1/4W |
| R303 | 1-249-417-11 | s | RES, CARBON 1K 5% 1/4W |
| R304 | 1-249-749-00 | s | RES, CARBON 2.2M 5% 1/4W |
| R305 | 1-249-437-11 | s | RES, CARBON 47K 5% 1/4W |
| R306 | 1-216-381-11 | s | RES, METAL OXIDE 0.22 5% 3W |
| R307 | 1-247-731-11 | s | RES, CARBON 22 5% 1/2W |
| R308 | 1-247-731-11 | s | RES, CARBON 22 5% 1/2W |
| R312 | 1-249-423-11 | s | RES, CARBON 3.3K 5% 1/4W |
| R313 | 1-249-423-11 | s | RES, CARBON 3.3K 5% 1/4W |
| R314 | 1-249-423-11 | s | RES, CARBON 3.3K 5% 1/4W |
| R315 | 1-249-417-11 | s | RES, CARBON 1K 5% 1/4W |
| R401 | 1-249-441-11 | s | RES, CARBON 100K 5% 1/4W |
| R404 | 1-247-742-11 | s | RES, CARBON 180 5% 1/2W |
| R405 | 1-249-421-11 | s | RES, CARBON 2.2K 5% 1/4W |
| R406 | 1-249-387-11 | s | RES, CARBON 3.3 5% 1/4W |
| R407 | 1-247-696-11 | s | RES, CARBON 47 5% 1/4W |
| R501 | 1-249-429-11 | s | RES, CARBON 10K 5% 1/4W |
| R502 | 1-249-429-11 | s | RES, CARBON 10K 5% 1/4W |
| R503 | 1-249-429-11 | s | RES, CARBON 10K 5% 1/4W |
| R504 | 1-249-433-11 | s | RES, CARBON 22K 5% 1/4W |
| R505 | 1-249-433-11 | s | RES, CARBON 22K 5% 1/4W |
| R506 | 1-249-425-11 | s | RES, CARBON 4.7K 5% 1/4W |
| R507 | 1-249-429-11 | s | RES, CARBON 10K 5% 1/4W |
| R508 | 1-249-429-11 | s | RES, CARBON 10K 5% 1/4W |
| R509 | 1-249-429-11 | s | RES, CARBON 10K 5% 1/4W |
| R512 | 1-247-739-11 | s | RES, CARBON 100 5% 1/2W |
| R513 | 1-249-414-11 | s | RES, CARBON 560 5% 1/4W |
| R514 | 1-249-417-11 | s | RES, CARBON 1K 5% 1/4W |
| R515 | 1-249-421-11 | s | RES, CARBON 2.2K 5% 1/4W |
| R516 | 1-249-428-11 | s | RES, CARBON 8.2K 5% 1/4W |
| R517 | 1-249-429-11 | s | RES, CARBON 10K 5% 1/4W |
| R518 | 1-249-417-11 | s | RES, CARBON 1K 5% 1/4W |
| R519 | 1-249-421-11 | s | RES, CARBON 2.2K 5% 1/4W |
| R520 | 1-249-428-11 | s | RES, CARBON 8.2K 5% 1/4W |
| R521 | 1-249-429-11 | s | RES, CARBON 10K 5% 1/4W |
| R524 | 1-249-429-11 | s | RES, CARBON 10K 5% 1/4W |
| R525 | 1-249-429-11 | s | RES, CARBON 10K 5% 1/4W |
| R528 | 1-249-429-11 | s | RES, CARBON 10K 5% 1/4W |
| R529 | 1-249-429-11 | s | RES, CARBON 10K 5% 1/4W |
| R530 | 1-216-381-11 | s | RES, METAL OXIDE 0.22 5% 3W |
| R531 | 1-249-412-11 | s | RES, CARBON 390 5% 1/4W |
| R532 | 1-249-397-11 | s | RES, CARBON 22 5% 1/4W |
| R533 | 1-249-397-11 | s | RES, CARBON 22 5% 1/4W |
| R534 | 1-249-441-11 | s | RES, CARBON 100K 5% 1/4W |
| R535 | 1-249-441-11 | s | RES, CARBON 100K 5% 1/4W |
| R536 | 1-249-420-11 | s | RES, CARBON 1.8K 5% 1/4W |
| R901 | 1-249-416-11 | s | RES, CARBON 820 5% 1/4W |
| R902 | 1-249-416-11 | s | RES, CARBON 820 5% 1/4W |
| R903 | 1-249-416-11 | s | RES, CARBON 820 5% 1/4W |
| R911 | 1-249-416-11 | s | RES, CARBON 820 5% 1/4W |
| R912 | 1-249-416-11 | s | RES, CARBON 820 5% 1/4W |
| R913 | 1-249-416-11 | s | RES, CARBON 820 5% 1/4W |
| RB201 | 1-231-410-00 | s | RESISTOR BLOCK 10K |
| RB301 | 1-231-410-00 | s | RESISTOR BLOCK 10K |

PC-34 BOARD, DVR-1000

| Ref. No. or Qty | Part No. | SP | Description |
|--------------------|--------------|----|--------------------------------------|
| 1pc | 1-620-895-11 | o | PC BOARD, PC-34 WITHOUT COMPONENT |
| D1 | 8-719-918-74 | s | DIODE GP-1S04 |

NOTE: Please see pages D-37 and D-38 for the part numbers of capacitors and resistors that are not listed in the parts list.

PC-36 BOARD, DVR-1000

| Ref. No. or Qty | Part No. | SP | Description |
|--------------------|----------|----|-------------|
|--------------------|----------|----|-------------|

The following components are included in the
END SENSOR assy; A-6029-017-A.

| | | | |
|-----|--------------|---|---------------------|
| D1 | 8-719-123-69 | s | DIODE SE310 |
| RV1 | 1-228-471-11 | s | RES. VAR, CERMET 1K |
| Q1 | 8-729-116-45 | s | TRANSISTOR PH110 |

PC-37 BOARD, DVR-1000

| Ref. No. or Qty | Part No. | SP | Description |
|--------------------|----------|----|-------------|
|--------------------|----------|----|-------------|

| | | | |
|-----|--------------|---|--------------------------------------|
| 1pc | 1-621-344-11 | o | PC BOARD, PC-37 WITHOUT COMPONENT |
| PH1 | 8-719-915-46 | s | DIODE GP-1S05 |

PD-36 BOARD, DVR-1000

| Ref. No. or Qty | Part No. | SP | Description |
|--------------------|--------------|----|--|
| 1pc | A-6023-043-A | o | COMPLETE PCB, PD-36 (This assembly includes the following parts.) |
| 6pcs | 7-682-648-09 | s | SCREW +PSW 3X8 |
| 6pcs | 7-684-023-04 | s | N 3, TYPE 2 |
| C1 | 1-161-494-00 | s | CAP, CERAMIC 0.022uF 30% 25V |
| C3 | 1-161-494-00 | s | CAP, CERAMIC 0.022uF 30% 25V |
| C5 | 1-162-294-31 | s | CAP, CERAMIC 0.001uF 10% 50V |
| C6 | 1-162-294-31 | s | CAP, CERAMIC 0.001uF 10% 50V |
| C7 | 1-162-294-31 | s | CAP, CERAMIC 0.001uF 10% 50V |
| C8 | 1-162-294-31 | s | CAP, CERAMIC 0.001uF 10% 50V |
| C9 | 1-162-294-31 | s | CAP, CERAMIC 0.001uF 10% 50V |
| C10 | 1-162-294-31 | s | CAP, CERAMIC 0.001uF 10% 50V |
| CN930M | 1-506-468-21 | o | RECEP, 3P, MALE |
| CN931M | 1-506-468-11 | o | RECEP, 3P, MALE |
| D1 | 8-719-911-55 | s | DIODE U05G |
| D2 | 8-719-911-55 | s | DIODE U05G |
| D3 | 8-719-911-55 | s | DIODE U05G |
| D4 | 8-719-911-55 | s | DIODE U05G |
| IC1 | 8-759-205-76 | s | IC TC504013BP |
| L1 | 1-421-370-00 | s | COIL, CHOKE |
| Q1 | 8-729-901-41 | s | TRANSISTOR 2SC1740S-R |
| Q2 | 8-729-901-41 | s | TRANSISTOR 2SC1740S-R |
| Q3 | 8-729-901-41 | s | TRANSISTOR 2SC1740S-R |
| Q4 | 8-729-173-36 | s | TRANSISTOR 2SA773-Q |
| Q5 | 8-729-371-53 | s | TRANSISTOR 2SA715 |
| Q6 | 8-729-316-23 | s | TRANSISTOR 2SC1162 |
| Q7 | 8-729-901-41 | s | TRANSISTOR 2SC1740S-R |
| Q8 | 8-729-173-36 | s | TRANSISTOR 2SA773-Q |
| Q9 | 8-729-371-53 | s | TRANSISTOR 2SA715 |
| Q10 | 8-729-316-23 | s | TRANSISTOR 2SC1162 |
| R1 | 1-249-429-11 | s | RES, CARBON 10K 5% 1/6W |
| R2 | 1-249-429-11 | s | RES, CARBON 10K 5% 1/6W |
| R3 | 1-249-429-11 | s | RES, CARBON 10K 5% 1/6W |
| R4 | 1-249-429-11 | s | RES, CARBON 10K 5% 1/6W |
| R5 | 1-249-421-11 | s | RES, CARBON 2.2K 5% 1/6W |
| R6 | 1-249-421-11 | s | RES, CARBON 2.2K 5% 1/6W |
| R7 | 1-249-421-11 | s | RES, CARBON 2.2K 5% 1/6W |
| R8 | 1-249-421-11 | s | RES, CARBON 2.2K 5% 1/6W |
| R9 | 1-249-429-11 | s | RES, CARBON 10K 5% 1/6W |
| R10 | 1-249-429-11 | s | RES, CARBON 10K 5% 1/6W |

PE-18 BOARD, DVR-1000

| Ref. No. or Qty | Part No. | SP | Description |
|--------------------|--------------|----|--------------------------------------|
| 1pc | 1-620-916-11 | o | PC BOARD, PE-18 WITHOUT COMPONENT |
| CN206M | 1-506-481-11 | o | RECEP, 2P, MALE |
| D1 | 8-719-919-67 | s | DIODE GL-9PG2 |

NOTE: Please see pages D-37 and D-38 for the part numbers of capacitors and resistors that are not listed in the parts list.

PR-87 BOARD, DVR-1000

Ref. No. or Qty Part No. SP Description

The following components are included in the CN-A PANEL assy: A-6032-069-A.

| | | | |
|--------|--------------|---|--------------------------|
| 2pcs | 7-682-648-09 | s | SCREW +PSW 3X8 |
| C1 | 1-124-248-00 | s | CAP, ELECT 22uF 20% 35V |
| C2 | 1-124-248-00 | s | CAP, ELECT 22uF 20% 35V |
| C4 | 1-124-236-00 | s | CAP, ELECT 47uF 20% 16V |
| CN920M | 1-506-477-11 | o | RECEP, 12P, MALE |
| CN921M | 1-506-480-21 | o | RECEP, 15P, MALE |
| CN922M | 1-506-480-11 | o | RECEP, 15P, MALE |
| CN923M | 1-506-471-11 | o | CONNECTOR, 6P, MALE |
| CN924F | 1-563-781-21 | s | RECEP, D-SUB 50P, FEMALE |
| D1 | 8-719-100-54 | s | DIODE RD9.1E-B2 |
| D2 | 8-719-100-54 | s | DIODE RD9.1E-B2 |
| ICA1 | 8-759-990-82 | s | IC TL082CP |
| ICA2 | 8-759-926-32 | s | IC AM26LS32PC |
| ICB1 | 8-759-926-31 | s | IC AM26LS31PC |
| ICB2 | 8-759-926-32 | s | IC AM26LS32PC |
| R1 | 1-249-417-11 | s | RES, CARBON 1K 5% 1/6W |
| R2 | 1-249-417-11 | s | RES, CARBON 1K 5% 1/6W |
| R7 | 1-249-417-11 | s | RES, CARBON 1K 5% 1/6W |

PS-138 BOARD, DVR-1000

Ref. No. or Qty Part No. SP Description

1pc A-6023-039-A o COMPLETE PCB, PS-138
(This assembly includes the following parts.)

| | | | |
|-------|--------------|---|--------------------------------|
| 1pc | 4-873-829-02 | o | HEAT SINK |
| 2pcs | 2-270-601-00 | o | SUPPORT |
| 1pc | 7-682-653-09 | s | SCREW +PSW 3X20 |
| 15pcs | 2-832-007-00 | s | BUSHING (K), INSULATING |
| 43pcs | 7-628-254-30 | s | +PSW, 2.6X10 |
| 3pcs | 4-875-726-00 | s | SHEET, INSULATING |
| 13pcs | 7-682-648-09 | s | SCREW +PSW 3X8 |
| 3pcs | 7-628-254-20 | s | +PSW, 2.6X8 |
| 2pcs | 7-628-254-10 | s | +PSW, 2.6X6 |
| 2pcs | 1-533-037-XX | s | HOLDER, FUSE |
| C1 | 1-161-744-00 | s | CAP, CERAMIC 0.01uF 400V |
| C2 | 1-161-744-00 | s | CAP, CERAMIC 0.01uF 400V |
| C3 | 1-161-744-00 | s | CAP, CERAMIC 0.01uF 400V |
| C4 | 1-161-744-00 | s | CAP, CERAMIC 0.01uF 400V |
| C5 | 1-125-468-11 | s | CAP, ELECT 1200uF 20% 200V |
| C6 | 1-125-468-11 | s | CAP, ELECT 1200uF 20% 200V |
| C7 | 1-125-468-11 | s | CAP, ELECT 1200uF 20% 200V |
| C8 | 1-125-468-11 | s | CAP, ELECT 1200uF 20% 200V |
| C9 | 1-125-468-11 | s | CAP, ELECT 1200uF 20% 200V |
| C10 | 1-125-468-11 | s | CAP, ELECT 1200uF 20% 200V |
| C11 | 1-126-149-11 | s | CAP, ELECT 3.3uF 20% 250V |
| C12 | 1-126-149-11 | s | CAP, ELECT 3.3uF 20% 250V |
| C13 | 1-161-742-00 | s | CAP, CERAMIC 0.0022uF 20% 400V |
| C14 | 1-126-149-11 | s | CAP, ELECT 3.3uF 20% 250V |
| C15 | 1-126-149-11 | s | CAP, ELECT 3.3uF 20% 250V |
| C16 | 1-161-742-00 | s | CAP, CERAMIC 0.0022uF 20% 400V |
| C17 | 1-126-149-11 | s | CAP, ELECT 3.3uF 20% 250V |
| C18 | 1-126-149-11 | s | CAP, ELECT 3.3uF 20% 250V |
| C19 | 1-161-742-00 | s | CAP, CERAMIC 0.0022uF 20% 400V |
| C20 | 1-124-534-11 | s | CAP, ELECT 680uF 20% 16V |
| C21 | 1-124-634-11 | s | CAP, ELECT 1uF 20% 450V |
| C22 | 1-126-149-11 | s | CAP, ELECT 3.3uF 20% 250V |
| C23 | 1-126-149-11 | s | CAP, ELECT 3.3uF 20% 250V |
| C30 | 1-130-710-00 | s | CAP, FILM 0.1uF 20% 250V |
| C102 | 1-124-491-11 | s | CAP, ELECT 680uF 20% 25V |
| C103 | 1-124-491-11 | s | CAP, ELECT 680uF 20% 25V |
| C104 | 1-126-148-11 | s | CAP, ELECT 820uF 20% 63V |
| C105 | 1-126-148-11 | s | CAP, ELECT 820uF 20% 63V |
| C106 | 1-161-898-11 | s | CAP, CERAMIC 0.47uF 50V |
| C107 | 1-124-568-00 | s | CAP, ELECT 4700uF 20% 10V |
| C108 | 1-124-568-00 | s | CAP, ELECT 4700uF 20% 10V |
| C110 | 1-124-521-11 | s | CAP, ELECT 6800uF 20% 10V |
| C111 | 1-124-521-11 | s | CAP, ELECT 6800uF 20% 10V |
| C113 | 1-126-143-11 | s | CAP, ELECT 470uF 20% 35V |
| C114 | 1-126-143-11 | s | CAP, ELECT 470uF 20% 35V |
| C115 | 1-126-143-11 | s | CAP, ELECT 470uF 20% 35V |
| C116 | 1-126-143-11 | s | CAP, ELECT 470uF 20% 35V |
| C121 | 1-124-579-11 | s | CAP, ELECT 1000uF 20% 16V |
| C122 | 1-124-579-11 | s | CAP, ELECT 1000uF 20% 16V |
| C123 | 1-124-579-11 | s | CAP, ELECT 1000uF 20% 16V |
| C124 | 1-124-579-11 | s | CAP, ELECT 1000uF 20% 16V |
| C125 | 1-124-579-11 | s | CAP, ELECT 1000uF 20% 16V |
| C126 | 1-124-579-11 | s | CAP, ELECT 1000uF 20% 16V |
| C127 | 1-124-599-00 | s | CAP, ELECT 220uF 20% 25V |
| C128 | 1-126-146-11 | s | CAP, ELECT 1000uF 20% 35V |
| C129 | 1-126-146-11 | s | CAP, ELECT 1000uF 20% 35V |
| C130 | 1-126-146-11 | s | CAP, ELECT 1000uF 20% 35V |
| C131 | 1-124-599-00 | s | CAP, ELECT 220uF 20% 25V |
| C134 | 1-126-146-11 | s | CAP, ELECT 1000uF 20% 35V |
| C135 | 1-126-146-11 | s | CAP, ELECT 1000uF 20% 35V |
| C136 | 1-126-146-11 | s | CAP, ELECT 1000uF 20% 35V |
| C137 | 1-124-599-00 | s | CAP, ELECT 220uF 20% 25V |
| C142 | 1-126-145-11 | s | CAP, ELECT 680uF 20% 35V |
| C143 | 1-126-145-11 | s | CAP, ELECT 680uF 20% 35V |
| C145 | 1-126-142-11 | s | CAP, ELECT 100uF 20% 35V |
| C146 | 1-126-142-11 | s | CAP, ELECT 100uF 20% 35V |

NOTE: Please see pages D-37 and D-38 for the part numbers of capacitors and resistors that are not listed in the parts list.

(PS-138 BOARD, DVR-1000)

| Ref. No. or Qty | Part No. | SP | Description |
|--------------------|-----------------------|----|--------------------------|
| CN103M | Δ 1-560-752-00 | o | RECEP, 9P, MALE |
| CN104M | 1-560-309-00 | o | RECEP, IL 3P, MALE |
| CN105M | 1-506-621-11 | o | RECEP, PS 12P, MALE |
| CN106M | 1-506-617-11 | o | RECEP, PS 4P, MALE |
| CN107M | 1-506-620-11 | o | RECEP, PS 10P, MALE |
| CN108M | 1-506-621-11 | o | RECEP, PS 12P, MALE |
| CN109M | 1-560-309-00 | o | RECEP, IL 3P, MALE |
| CN110F | 1-509-985-00 | o | HOUSING, IL 4P |
| | 1-560-298-00 | o | CONTACT, FEMALE AWG22-28 |
| CN110M | Δ 1-560-301-00 | o | RECEP, IL 4P, MALE |
| CN111F | 1-509-986-00 | o | HOUSING, IL 5P |
| | 1-560-298-00 | o | CONTACT, FEMALE AWG22-28 |
| CN111M | Δ 1-560-302-00 | o | RECEP, IL 5P, MALE |
| CN112F | 1-509-988-00 | o | HOUSING, IL 8P |
| | 1-560-298-00 | o | CONTACT, FEMALE AWG22-28 |
| CN112M | Δ 1-560-304-00 | o | RECEP, IL 8P, MALE |
| CN113 | 1-560-883-11 | o | RECEP, 7P, MALE |
| CN114M | 1-560-883-11 | o | RECEP, 7P, MALE |
| CN115M | 1-560-883-11 | o | RECEP, 7P, MALE |
| CN116M | 1-560-883-11 | o | RECEP, 7P, MALE |
| CN117M | 1-560-883-11 | o | RECEP, 7P, MALE |
| CN118M | 1-560-883-11 | o | RECEP, 7P, MALE |
| CN119F | 1-509-988-00 | o | HOUSING, IL 8P |
| | 1-560-298-00 | o | CONTACT, FEMALE AWG22-28 |
| CN119M | 1-560-304-00 | o | RECEP, IL 8P, MALE |
| CN120F | 1-509-988-00 | o | HOUSING, IL 8P |
| | 1-560-298-00 | o | CONTACT, FEMALE AWG22-28 |
| CN120M | 1-560-304-00 | o | RECEP, IL 8P, MALE |
| CN121F | 1-509-985-00 | o | HOUSING, IL 4P |
| | 1-560-298-00 | o | CONTACT, FEMALE AWG22-28 |
| CN122F | 1-509-986-00 | o | HOUSING, IL 5P |
| | 1-560-298-00 | o | CONTACT, FEMALE AWG22-28 |
| CN123F | 1-509-988-00 | o | HOUSING, IL 8P |
| | 1-560-298-00 | o | CONTACT, FEMALE AWG22-28 |
| CN124M | 1-561-087-00 | o | HOUSING, 15P |
| | 1-535-207-21 | o | CONTACT, MALE AWG18-24 |
| CP1 | 1-235-966-11 | s | CR BLOCK, C=2200PF R=20 |
| CP101 | 1-235-966-11 | s | CR BLOCK, C=2200PF R=20 |
| CP103 | 1-235-965-11 | s | CR BLOCK, C=0.022 R=20 |
| CP104 | 1-235-965-11 | s | CR BLOCK, C=0.022 R=20 |
| CP106 | 1-235-966-11 | s | CR BLOCK, C=2200PF R=20 |
| CP107 | 1-235-966-11 | s | CR BLOCK, C=2200PF R=20 |
| CP108 | 1-235-965-11 | s | CR BLOCK, C=0.022 R=20 |
| CP109 | 1-235-965-11 | s | CR BLOCK, C=0.022 R=20 |
| CP110 | 1-235-966-11 | s | CR BLOCK, C=2200PF R=20 |
| CP111 | 1-235-966-11 | s | CR BLOCK, C=2200PF R=20 |
| CP112 | 1-235-966-11 | s | CR BLOCK, C=2200PF R=20 |
| D1 | 8-719-200-02 | s | DIODE 10E-2 |
| D2 | 8-719-500-27 | s | DIODE S15VB60 |
| D3 | 8-719-200-02 | s | DIODE 10E-2 |
| D4 | 8-719-200-02 | s | DIODE 10E-2 |
| D5 | 8-719-100-90 | s | DIODE RD24E-B2 |
| D6 | 8-719-100-71 | s | DIODE RD15E-B2 |
| D7 | 8-719-100-77 | s | DIODE RD18E-B2 |

(PS-138 BOARD, DVR-1000)

| Ref. No. or Qty | Part No. | SP | Description |
|--------------------|----------------|----|--------------------------|
| D8 | 8-719-901-17 | s | DIODE V11L |
| D9 | 1-806-660-11 | s | DIODE ESAB85-009 |
| D101 | 8-719-903-16 | s | DIODE ESAC92-02 |
| D102 | 8-719-500-71 | s | DIODE D8LC40 |
| D103 | 8-719-901-18 | s | DIODE ESAD83-004 |
| D104 | 8-719-901-18 | s | DIODE ESADE83-004 |
| D106 | 8-719-550-02 | s | DIODE S5KC20R |
| D107 | 8-719-551-02 | s | DIODE S5KC20R |
| D108 | 8-719-500-31 | s | DIODE S10SC4MR |
| D109 | 8-719-500-31 | s | DIODE S10SC4MR |
| D110 | 8-719-928-19 | s | DIODE ESAC92-02 |
| D111 | 8-719-928-19 | s | DIODE ESAC92-02 |
| D112 | 8-719-928-19 | s | DIODE ESAC92-02 |
| D113 | 8-719-907-25 | s | DIODE ERA84-009 |
| D114 | 8-719-100-86 | s | DIODE RD22E-B2 |
| D115 | 8-719-100-80 | s | DIODE RD20E-B2 |
| D116 | 8-719-908-06 | s | DIODE ERA81-005 |
| F1 | Δ 1-532-783-21 | s | FUSE, MICRO 5A |
| F2 | Δ 1-532-783-21 | s | FUSE, MICRO 5A |
| F3 | Δ 1-532-779-21 | s | FUSE, MICRO 2A |
| F10 | Δ 1-532-456-08 | s | FUSE, THERMAL 109° C 10A |
| F11 | Δ 1-532-826-11 | s | FUSE, GLASS TUBE 2.5A |
| FB101 | 1-543-528-11 | s | BEAD, AMORPHOUS |
| FB102 | 1-543-528-11 | s | BEAD, AMORPHOUS |
| IC1 | 8-741-128-10 | s | IC BX1281 |
| IC2 | 8-741-128-10 | s | IC BX1281 |
| IC3 | 8-741-128-10 | s | IC BX1281 |
| IC4 | 8-741-128-10 | s | IC BX1281 |
| IC5 | 8-741-128-10 | s | IC BX1281 |
| IC6 | 8-741-128-10 | s | IC BX1281 |
| IC7 | Δ 8-719-902-56 | s | IC PC817 |
| IC103 | 8-759-700-24 | s | IC NJM79M12A |
| IC104 | 8-759-170-12 | s | IC uPC78M12H |
| IC105 | 8-759-170-12 | s | IC uPC78M12H |
| L1 | 1-408-654-00 | s | INDUCTOR, 1mH 5% |
| L101 | 1-421-936-11 | s | COIL, CHOKE 400uH |
| L102 | 1-421-936-11 | s | COIL, CHOKE 400uH |
| L103 | 1-421-937-11 | s | COIL, CHOKE 100uH |
| L104 | 1-421-937-11 | s | COIL, CHOKE 100uH |
| L106 | 1-408-299-00 | s | COIL, CHOKE 20mH |
| L107 | 1-408-299-00 | s | COIL, CHOKE 20mH |
| L109 | 1-413-091-00 | s | COIL, SN |
| L110 | 1-421-459-00 | s | COIL, CHOKE |
| L111 | 1-413-091-00 | s | COIL, SN |
| L112 | 1-421-459-00 | s | COIL, CHOKE |
| L113 | 1-413-091-00 | s | COIL, SN |
| L114 | 1-421-459-00 | s | COIL, CHOKE |
| L115 | 1-413-091-00 | s | COIL, SN |
| L116 | 1-421-459-00 | s | COIL, CHOKE |
| L117 | 1-413-091-00 | s | COIL, SN |
| L118 | 1-421-459-00 | s | COIL, CHOKE |
| L119 | 1-413-091-00 | s | COIL, SN |
| L120 | 1-421-459-00 | s | COIL, CHOKE |
| L121 | 1-459-106-00 | s | COIL, DUST CORE |
| L122 | 1-421-329-00 | s | COIL, CHOKE |
| L123 | 1-421-329-00 | s | COIL, CHOKE |
| Q1 | 8-729-208-29 | s | TRANSISTOR 25K385 |
| Q2 | 8-729-208-29 | s | TRANSISTOR 25K385 |
| Q3 | 8-729-208-29 | s | TRANSISTOR 25K385 |
| Q4 | 8-729-208-29 | s | TRANSISTOR 25K385 |
| Q5 | 8-729-208-29 | s | TRANSISTOR 25K385 |
| Q6 | 8-729-208-29 | s | TRANSISTOR 25K385 |
| Q7 | 8-729-307-58 | s | TRANSISTOR 25C1775A |
| Q8 | 8-729-208-28 | s | TRANSISTOR 25K528 |
| Q101 | 8-729-904-38 | s | TRANSISTOR 25D1118 |
| Q102 | 8-729-984-70 | s | TRANSISTOR 25D847 |
| Q103 | 8-729-984-70 | s | TRANSISTOR 25D847 |
| Q104 | 8-729-984-70 | s | TRANSISTOR 25D847 |
| Q105 | 8-729-984-70 | s | TRANSISTOR 25D847 |
| Q106 | 8-729-900-07 | s | TRANSISTOR 25B757-B |
| R1 | Δ 1-205-902-21 | s | RES, CEMENT 12 5% 20W |
| R4 | 1-205-903-11 | s | RES, CEMENT 24K 5% 5W |
| R5 | 1-205-903-11 | s | RES, CEMENT 24K 5% 5W |

NOTE: Please see pages D-37 and D-38 for the part numbers of capacitors and resistors that are not listed in the parts list.

(PS-138 BOARD, DVR-1000)

| Ref. No. or Qty | Part No. | SP | Description |
|--------------------|--------------|----|---------------------------|
| R8 | 1-207-537-00 | s | RES, WIREWOUND 150 10% 3W |
| R9 | 1-249-417-11 | s | RES, CARBON 1K 5% 1/6W |
| R12 | 1-207-537-00 | s | RES, WIREWOUND 150 10% 3W |
| R15 | 1-207-537-00 | s | RES, WIREWOUND 150 10% 3W |
| R16 | 1-249-420-11 | s | RES, CARBON 1.8K 5% 1/6W |
| R17 | 1-249-420-11 | s | RES, CARBON 1.8K 5% 1/6W |
| R18 | 1-247-749-11 | s | RES, CARBON 560 5% 1/2W |
| R19 | 1-215-904-11 | s | RES, METAL 100K 5% 2W |
| R20 | 1-249-417-11 | s | RES, CARBON 1K 5% 1/6W |
| R21 | 1-249-417-11 | s | RES, CARBON 1K 5% 1/6W |
| R22 | 1-249-441-11 | s | RES, CARBON 100K 5% 1/6W |
| R23 | 1-217-699-11 | s | RES, FUSE 750 5% 2W |
| R24 | 1-217-699-11 | s | RES, FUSE 750 5% 2W |
| R101 | 1-249-420-11 | s | RES, CARBON 1.8K 5% 1/6W |
| R102 | 1-249-420-11 | s | RES, CARBON 1.8K 5% 1/6W |
| R103 | 1-249-420-11 | s | RES, CARBON 1.8K 5% 1/6W |
| R104 | 1-249-420-11 | s | RES, CARBON 1.8K 5% 1/6W |
| R107 | 1-249-397-11 | s | RES, CARBON 22 5% 1/6W |
| R108 | 1-249-433-11 | s | RES, CARBON 22K 5% 1/6W |
| R109 | 1-249-416-11 | s | RES, CARBON 820 5% 1/6W |
| R110 | 1-249-419-11 | s | RES, CARBON 1.5K 5% 1/6W |
| R111 | 1-249-417-11 | s | RES, CARBON 1K 5% 1/6W |
| R112 | 1-216-771-11 | s | RES, METAL 82 5% 10W |
| R113 | 1-216-772-11 | s | RES, METAL 390 5% 10W |
| R114 | 1-216-770-11 | s | RES, METAL 33 5% 10W |
| R115 | 1-216-770-11 | s | RES, METAL 33 5% 10W |
| R116 | 1-216-769-11 | s | RES, METAL 10 5% 10W |
| R123 | 1-207-612-00 | s | RES, WIREWOUND 0.1 10% 3W |
| R124 | 1-207-612-00 | s | RES, WIREWOUND 0.1 10% 3W |
| R125 | 1-207-612-00 | s | RES, WIREWOUND 0.1 10% 3W |
| R126 | 1-249-409-11 | s | RES, CARBON 220 5% 1/6W |
| R127 | 1-207-612-00 | s | RES, WIREWOUND 0.1 10% 3W |
| R128 | 1-249-417-11 | s | RES, CARBON 1K 5% 1/6W |
| R129 | 1-207-612-00 | s | RES, WIREWOUND 0.1 10% 3W |
| R130 | 1-249-417-11 | s | RES, CARBON 1K 5% 1/6W |
| RY1 | 1-515-193-00 | s | RELAY |
| S1 | 1-570-258-41 | s | SWITCH, THERMAL 80°C |
| T1 | 1-437-198-11 | s | TRANSFORMER, DRIVE |
| T2 | 1-437-198-11 | s | TRANSFORMER, DRIVE |
| T3 | 1-437-198-11 | s | TRANSFORMER, DRIVE |
| T4 | 1-437-198-11 | s | TRANSFORMER, DRIVE |
| T5 | 1-437-198-11 | s | TRANSFORMER, DRIVE |
| T6 | 1-437-198-11 | s | TRANSFORMER, DRIVE |
| T7 | 1-448-791-12 | s | TRANSFORMER, CONVERTER |
| T8 | 1-448-789-11 | s | TRANSFORMER, CONVERTER |
| T9 | 1-448-798-11 | s | TRANSFORMER, CONVERTER |
| T10 | 1-448-792-11 | s | TRANSFORMER, CONVERTER |
| VDR1 | 1-806-356-00 | s | VARISTOR ENB461-10A |

PS-139 BOARD, DVR-1000

| Ref. No. or Qty | Part No. | SP | Description |
|--------------------|--------------|----|---|
| 1pc | A-6017-142-A | o | COMPLETE PCB, PS-139 (This assembly includes the following parts.) |
| 1pc | 3-674-390-00 | o | HOLDER (B), LED |
| 2pcs | 2-832-007-00 | s | BUSHING (K), INSULATING |
| 2pcs | 7-628-254-30 | s | +PSW, 2.6X10 |
| 2pcs | 7-622-207-05 | s | N 2.6, TYPE 2 |
| C1 | 1-161-055-00 | s | CAP, CERAMIC 0.022uF 10% 50V |
| C2 | 1-126-144-11 | s | CAP, ELECT 330uF 20% 35V |
| C3 | 1-161-055-00 | s | CAP, CERAMIC 0.022uF 10% 50V |
| C4 | 1-161-055-00 | s | CAP, CERAMIC 0.022uF 10% 50V |
| C5 | 1-162-814-11 | s | CAP, CERAMIC 0.47uF 10% 50V |
| C6 | 1-136-157-00 | s | CAP, MYLAR 0.022uF 10% 50V |
| C7 | 1-136-157-00 | s | CAP, MYLAR 0.022uF 10% 50V |
| C8 | 1-131-347-00 | s | CAP, TANT 1uF 10% 35V |
| C10 | 1-126-140-11 | s | CAP, ELECT 470uF 20% 25V |
| C11 | 1-162-814-11 | s | CAP, CERAMIC 0.47uF 10% 50V |
| C12 | 1-124-559-51 | s | CAP, ELECT 1000uF 20% 10V |
| C13 | 1-136-157-00 | s | CAP, MYLAR 0.022uF 10% 50V |
| C14 | 1-131-347-00 | s | CAP, TANT 1uF 10% 35V |
| C15 | 1-136-157-00 | s | CAP, MYLAR 0.022uF 10% 50V |
| C16 | 1-124-489-11 | s | CAP, ELECT 150uF 20% 25V |
| C17 | 1-161-055-00 | s | CAP, CERAMIC 0.022uF 10% 50V |
| C18 | 1-130-475-00 | s | CAP, MYLAR 0.0022uF 5% 50V |
| CN509M | 1-566-402-11 | o | RECEP, 24P, MALE |
| CN510F | 1-563-769-11 | s | RECEP, ROUND 8P, FEMALE |
| CP1 | 1-235-966-11 | s | CR BLOCK, C=2200PF R=20 |
| CP2 | 1-235-966-11 | s | CR BLOCK, C=2200PF R=20 |
| D1 | 8-719-116-07 | s | DIODE RD16E-B |
| D2 | 8-719-113-07 | s | DIODE RD13E-B |
| D3 | 8-719-907-30 | s | DIODE ERB84-009 |
| D4 | 8-719-903-06 | s | DIODE ERC84-009 |
| D5 | 8-719-918-88 | s | DIODE ISS198 |
| D6 | 8-719-918-88 | s | DIODE ISS198 |
| D7 | 8-719-918-88 | s | DIODE ISS198 |
| D8 | 8-719-918-88 | s | DIODE ISS198 |
| D9 | 8-719-918-88 | s | DIODE ISS198 |
| D10 | 8-719-918-88 | s | DIODE ISS198 |
| D11 | 8-719-918-88 | s | DIODE ISS198 |
| D12 | 8-719-918-88 | s | DIODE ISS198 |
| D13 | 8-719-918-88 | s | DIODE ISS198 |
| D14 | 8-719-918-88 | s | DIODE ISS198 |
| D15 | 8-719-918-88 | s | DIODE ISS198 |
| D16 | 8-719-918-88 | s | DIODE ISS198 |
| D17 | 8-719-918-88 | s | DIODE ISS198 |
| D18 | 8-719-918-88 | s | DIODE ISS198 |
| D19 | 8-719-918-88 | s | DIODE ISS198 |
| D20 | 8-719-905-54 | s | DIODE EBG5504S |
| IC1 | 8-741-128-10 | s | IC BX1281 |
| IC2 | 8-759-937-59 | s | IC MB3759 |
| IC3 | 8-759-937-59 | s | IC MB3759 |
| IC4 | 8-741-128-10 | s | IC BX1281 |
| L1 | 1-421-329-00 | s | COIL, CHOKE |
| L2 | 1-413-089-00 | s | COIL, SN |
| L3 | 1-413-090-21 | s | COIL, SN |
| L4 | 1-421-329-00 | s | COIL, CHOKE |
| Q1 | 8-729-304-35 | s | TRANSISTOR 2SJ122 |
| Q2 | 8-729-304-35 | s | TRANSISTOR 2SJ122 |
| Q3 | 8-729-900-33 | s | TRANSISTOR DTC144EF |
| Q4 | 8-729-900-33 | s | TRANSISTOR DTC144EF |
| R1 | 1-249-416-11 | s | RES, CARBON 820 5% 1/6W |
| R2 | 1-249-416-11 | s | RES, CARBON 820 5% 1/6W |
| R3 | 1-249-437-11 | s | RES, CARBON 47K 5% 1/6W |
| R4 | 1-249-437-11 | s | RES, CARBON 47K 5% 1/6W |
| R5 | 1-247-849-00 | s | RES, CARBON 5.6K 5% 1/6W |
| R6 | 1-249-425-11 | s | RES, CARBON 4.7K 5% 1/6W |
| R7 | 1-249-438-11 | s | RES, CARBON 56K 5% 1/6W |
| R8 | 1-249-437-11 | s | RES, CARBON 47K 5% 1/6W |
| R9 | 1-249-437-11 | s | RES, CARBON 47K 5% 1/6W |
| R10 | 1-249-409-11 | s | RES, CARBON 220 5% 1/6W |
| R11 | 1-249-409-11 | s | RES, CARBON 220 5% 1/6W |
| R13 | 1-249-433-11 | s | RES, CARBON 22K 5% 1/6W |
| R14 | 1-249-414-11 | s | RES, CARBON 560 5% 1/6W |

NOTE: Please see pages D-37 and D-38 for the part numbers of capacitors and resistors that are not listed in the parts list.

(PS-139 BOARD, DVR-1000)

| Ref. No. or Qty | Part No. | SP | Description |
|--------------------|--------------|----|---------------------------|
| R17 | 1-249-433-11 | s | RES, CARBON 22K 5% 1/6W |
| R18 | 1-207-612-00 | s | RES, WIREWOUND 0.1 10% 3W |
| R19 | 1-249-416-11 | s | RES, CARBON 820 5% 1/6W |
| R22 | 1-247-885-00 | s | RES, CARBON 180K 5% 1/6W |
| R24 | 1-249-425-11 | s | RES, CARBON 4.7K 5% 1/6W |
| R25 | 1-249-428-11 | s | RES, CARBON 8.2K 5% 1/6W |
| R26 | 1-217-212-00 | s | RES, WIREWOUND 10 10% 2W |
| R27 | 1-207-612-00 | s | RES, WIREWOUND 0.1 10% 3W |
| R28 | 1-249-437-11 | s | RES, CARBON 47K 5% 1/6W |
| R29 | 1-249-435-11 | s | RES, CARBON 33K 5% 1/6W |
| R30 | 1-249-416-11 | s | RES, CARBON 820 5% 1/6W |
| R31 | 1-249-414-11 | s | RES, CARBON 560 5% 1/6W |
| R32 | 1-249-437-11 | s | RES, CARBON 47K 5% 1/6W |
| R33 | 1-249-425-11 | s | RES, CARBON 4.7K 5% 1/6W |
| R34 | 1-249-411-11 | s | RES, CARBON 330 5% 1/6W |
| R35 | 1-249-425-11 | s | RES, CARBON 4.7K 5% 1/6W |
| R36 | 1-249-409-11 | s | RES, CARBON 220 5% 1/6W |
| R37 | 1-249-425-11 | s | RES, CARBON 4.7K 5% 1/6W |
| RV1 | 1-230-843-11 | s | RES, VAR, METAL 10K |
| RV2 | 1-230-842-11 | s | RES, VAR, METAL 5K |
| RV3 | 1-230-843-11 | s | RES, VAR, METAL 10K |
| RV4 | 1-230-845-11 | s | RES, VAR, METAL 50K |
| S13 | 1-554-041-11 | s | SWITCH WITH LED, PUSH |
| S14 | 1-554-041-11 | s | SWITCH WITH LED, PUSH |
| S15 | 1-554-041-11 | s | SWITCH WITH LED, PUSH |

RE-32 BOARD, DVR-1000

| Ref. No. or Qty | Part No. | SP | Description |
|--------------------|--------------|----|--|
| 1pc | A-6023-040-A | o | COMPLETE PCB, RE-32 (This assembly includes the following parts.) |
| C4 | 1-130-483-00 | s | CAP, MYLAR 0.01uF 5% 50V |
| C8 | 1-130-483-00 | s | CAP, MYLAR 0.01uF 5% 50V |
| C14 | 1-130-483-00 | s | CAP, MYLAR 0.01uF 5% 50V |
| C17 | 1-130-483-00 | s | CAP, MYLAR 0.01uF 5% 50V |
| C18 | 1-130-483-00 | s | CAP, MYLAR 0.01uF 5% 50V |
| C20 | 1-130-483-00 | s | CAP, MYLAR 0.01uF 5% 50V |
| C21 | 1-130-483-00 | s | CAP, MYLAR 0.01uF 5% 50V |
| C22 | 1-130-477-00 | s | CAP, MYLAR 0.0033uF 5% 50V |
| C23 | 1-130-494-11 | s | CAP, MYLAR 0.082uF 5% 50V |
| C24 | 1-162-810-11 | s | CAP, CERAMIC 0.22uF 10% 50V |
| C26 | 1-130-475-00 | s | CAP, MYLAR 0.0022uF 5% 50V |
| C28 | 1-130-489-00 | s | CAP, MYLAR 0.833uF 5% 50V |
| C30 | 1-131-353-00 | s | CAP, TANT 10uF 10% 35V |
| C33 | 1-130-471-00 | s | CAP, MYLAR 0.001uF 5% 50V |
| C35 | 1-131-349-00 | s | CAP, TANT 2.2uF 10% 35V |
| C38 | 1-131-353-00 | s | CAP, TANT 10uF 10% 35V |
| C40 | 1-130-497-00 | s | CAP, MYLAR 0.15uF 5% 50V |
| C41 | 1-130-475-00 | s | CAP, MYLAR 0.0022uF 5% 50V |
| C101 | 1-162-812-11 | s | CAP, CERAMIC 0.33uF 10% 50V |
| CN113F | 1-561-975-11 | o | RECEP, 7P, FEMALE |
| CN114F | 1-561-975-11 | o | RECEP, 7P, FEMALE |
| CN115F | 1-561-975-11 | o | RECEP, 7P, FEMALE |
| CN116F | 1-561-975-11 | o | RECEP, 7P, FEMALE |
| CN117F | 1-561-975-11 | o | RECEP, 7P, FEMALE |
| CN118F | 1-561-975-11 | o | RECEP, 7P, FEMALE |
| D1 | 8-719-911-19 | s | DIODE 1SS119 |
| D2 | 8-719-911-19 | s | DIODE 1SS119 |
| D3 | 8-719-100-21 | s | DIODE RD3.9E-B2 |
| D4 | 8-719-911-19 | s | DIODE 1SS119 |
| D5 | 8-719-911-19 | s | DIODE 1SS119 |
| D6 | 8-719-100-21 | s | DIODE RD3.9E-B2 |
| D7 | 8-719-911-19 | s | DIODE 1SS119 |
| D8 | 8-719-911-19 | s | DIODE 1SS119 |
| D9 | 8-719-100-21 | s | DIODE RD3.9E-B2 |
| D10 | 8-719-102-51 | s | DIODE 1S251 |
| D11 | 8-719-102-51 | s | DIODE 1S251 |
| D13 | 8-719-911-19 | s | DIODE 1SS119 |
| D14 | 8-719-100-54 | s | DIODE RD9.1E-B2 |
| IC1 | 8-759-708-05 | s | IC NJM78L05A |
| IC2 | 8-759-135-80 | s | IC uPC358C |
| IC3 | 8-759-990-84 | s | IC TL084CN |
| IC4 | 8-719-919-78 | s | IC PC-627 |
| IC5 | 8-759-133-90 | s | IC uPC339C |
| IC6 | 8-759-937-59 | s | IC MB3759 |
| IC7 | 8-759-240-49 | s | IC TC4049BP |
| IC8 | 8-759-040-11 | s | IC MC1401BCP |
| IC9 | 8-759-040-01 | s | IC MC14001BCP |
| IC10 | 8-759-045-38 | s | IC MC14538BCP |
| IC11 | 8-759-937-59 | s | IC MB3759 |
| L1 | 1-421-329-00 | s | COIL, CHOKE |
| L2 | 1-421-329-00 | s | COIL, CHOKE |
| Q1 | 8-729-169-02 | s | TRANSISTOR 2SC2690A |
| Q2 | 8-729-122-02 | s | TRANSISTOR 2SA1220A |
| Q3 | 8-729-122-02 | s | TRANSISTOR 2SA1220A |
| Q4 | 8-729-122-02 | s | TRANSISTOR 2SA1220A |
| Q5 | 8-729-900-65 | s | TRANSISTOR DTA144ES |
| Q6 | 8-729-105-72 | s | TRANSISTOR 2SK523-L1 |
| Q7 | 8-729-105-72 | s | TRANSISTOR 2SK523-L1 |
| Q8 | 8-729-900-65 | s | TRANSISTOR DTA144ES |
| Q9 | 8-729-900-85 | s | TRANSISTOR DTC144WS |
| Q10 | 8-729-900-65 | s | TRANSISTOR DTA144ES |
| Q11 | 8-729-113-33 | s | TRANSISTOR 2SB733-4 |
| R1 | 1-249-401-11 | s | RES, CARBON 47 5% 1/6W |
| R2 | 1-249-397-11 | s | RES, CARBON 22 5% 1/6W |
| R3 | 1-249-423-11 | s | RES, CARBON 3.3K 5% 1/6W |
| R4 | 1-249-409-11 | s | RES, CARBON 220 5% 1/6W |
| R5 | 1-249-415-11 | s | RES, CARBON 680 5% 1/6W |
| R9 | 1-249-425-11 | s | RES, CARBON 4.7K 5% 1/6W |
| R10 | 1-247-885-00 | s | RES, CARBON 180K 5% 1/6W |
| R11 | 1-249-421-11 | s | RES, CARBON 2.2K 5% 1/6W |

NOTE: Please see pages D-37 and D-38 for the part numbers of capacitors and resistors that are not listed in the parts list.

(RE-32 BOARD, DVR-1000)

| Ref. No. or Qty | Part No. | SP | Description |
|--------------------|--------------|----|--------------------------|
| R12 | 1-249-425-11 | s | RES, CARBON 4.7K 5% 1/6W |
| R14 | 1-249-421-11 | s | RES, CARBON 2.2K 5% 1/6W |
| R15 | 1-249-425-11 | s | RES, CARBON 4.7K 5% 1/6W |
| R16 | 1-249-401-11 | s | RES, CARBON 47 5% 1/6W |
| R17 | 1-249-397-11 | s | RES, CARBON 22 5% 1/6W |
| R18 | 1-249-423-11 | s | RES, CARBON 3.3K 5% 1/6W |
| R19 | 1-249-409-11 | s | RES, CARBON 220 5% 1/6W |
| R20 | 1-249-415-11 | s | RES, CARBON 680 5% 1/6W |
| R24 | 1-249-425-11 | s | RES, CARBON 4.7K 5% 1/6W |
| R25 | 1-247-885-00 | s | RES, CARBON 180K 5% 1/6W |
| R26 | 1-249-421-11 | s | RES, CARBON 2.2K 5% 1/6W |
| R27 | 1-249-425-11 | s | RES, CARBON 4.7K 5% 1/6W |
| R29 | 1-249-421-11 | s | RES, CARBON 2.2K 5% 1/6W |
| R30 | 1-249-425-11 | s | RES, CARBON 4.7K 5% 1/6W |
| R31 | 1-249-387-11 | s | RES, CARBON 3.3 5% 1/6W |
| R32 | 1-249-387-11 | s | RES, CARBON 3.3 5% 1/6W |
| R33 | 1-249-393-11 | s | RES, CARBON 10 5% 1/6W |
| R34 | 1-249-423-11 | s | RES, CARBON 3.3K 5% 1/6W |
| R35 | 1-249-409-11 | s | RES, CARBON 220 5% 1/6W |
| R36 | 1-249-415-11 | s | RES, CARBON 680 5% 1/6W |
| R37 | 1-247-849-00 | s | RES, CARBON 5.6K 5% 1/6W |
| R40 | 1-249-420-11 | s | RES, CARBON 1.8K 5% 1/6W |
| R41 | 1-249-425-11 | s | RES, CARBON 4.7K 5% 1/6W |
| R42 | 1-249-405-11 | s | RES, CARBON 100 5% 1/6W |
| R44 | 1-249-405-11 | s | RES, CARBON 100 5% 1/6W |
| R45 | 1-249-425-11 | s | RES, CARBON 4.7K 5% 1/6W |
| R46 | 1-249-403-11 | s | RES, CARBON 68 5% 1/6W |
| R47 | 1-249-415-11 | s | RES, CARBON 680 5% 1/6W |
| R48 | 1-249-415-11 | s | RES, CARBON 680 5% 1/6W |
| R49 | 1-249-432-11 | s | RES, CARBON 18K 5% 1/6W |
| R50 | 1-249-430-11 | s | RES, CARBON 12K 5% 1/4W |
| R51 | 1-247-849-00 | s | RES, CARBON 5.6K 5% 1/6W |
| R52 | 1-249-438-11 | s | RES, CARBON 56K 5% 1/6W |
| R53 | 1-249-424-11 | s | RES, CARBON 3.9K 5% 1/6W |
| R54 | 1-249-433-11 | s | RES, CARBON 22K 5% 1/6W |
| R55 | 1-215-421-00 | s | RES, METAL 1K 1% 1/6W |
| R56 | 1-249-429-11 | s | RES, CARBON 10K 5% 1/6W |
| R57 | 1-249-438-11 | s | RES, CARBON 56K 5% 1/6W |
| R58 | 1-249-438-11 | s | RES, CARBON 56K 5% 1/6W |
| R59 | 1-249-433-11 | s | RES, CARBON 22K 5% 1/6W |
| R60 | 1-249-437-11 | s | RES, CARBON 47K 5% 1/6W |
| R62 | 1-249-435-11 | s | RES, CARBON 33K 5% 1/6W |
| R63 | 1-249-435-11 | s | RES, CARBON 33K 5% 1/6W |
| R64 | 1-249-425-11 | s | RES, CARBON 4.7K 5% 1/6W |
| R66 | 1-249-409-11 | s | RES, CARBON 220 5% 1/6W |
| R67 | 1-249-425-11 | s | RES, CARBON 4.7K 5% 1/6W |
| R68 | 1-249-425-11 | s | RES, CARBON 4.7K 5% 1/6W |
| R69 | 1-249-409-11 | s | RES, CARBON 220 5% 1/6W |
| R70 | 1-249-431-11 | s | RES, CARBON 15K 5% 1/6W |
| R72 | 1-249-435-11 | s | RES, CARBON 33K 5% 1/6W |
| R73 | 1-249-410-11 | s | RES, CARBON 270 5% 1/6W |
| R74 | 1-249-425-11 | s | RES, CARBON 4.7K 5% 1/6W |
| R75 | 1-247-849-00 | s | RES, CARBON 5.6K 5% 1/6W |
| R76 | 1-249-397-11 | s | RES, CARBON 22 5% 1/6W |
| R77 | 1-249-405-11 | s | RES, CARBON 100 5% 1/6W |
| R79 | 1-249-441-11 | s | RES, CARBON 100K 5% 1/6W |
| R80 | 1-249-431-11 | s | RES, CARBON 15K 5% 1/6W |
| R81 | 1-247-885-00 | s | RES, CARBON 180K 5% 1/6W |
| R82 | 1-249-428-11 | s | RES, CARBON 8.2K 5% 1/6W |
| R83 | 1-249-419-11 | s | RES, CARBON 1.5K 5% 1/6W |
| R84 | 1-249-423-11 | s | RES, CARBON 3.3K 5% 1/6W |
| R85 | 1-249-431-11 | s | RES, CARBON 15K 5% 1/6W |
| R86 | 1-249-441-11 | s | RES, CARBON 100K 5% 1/6W |
| R87 | 1-249-431-11 | s | RES, CARBON 15K 5% 1/6W |
| R88 | 1-215-435-00 | s | RES, METAL 3.9K 1% 1/6W |
| RV1 | 1-230-842-11 | s | RES, VAR, METAL 5K |
| RV2 | 1-230-840-11 | s | RES, VAR, METAL 1K |
| RV3 | 1-230-842-11 | s | RES, VAR, METAL 5K |
| RV4 | 1-230-840-11 | s | RES, VAR, METAL 1K |
| RV5 | 1-230-842-11 | s | RES, VAR, METAL 5K |
| RV6 | 1-230-838-11 | s | RES, VAR, METAL 200 |
| RV7 | 1-230-843-11 | s | RES, VAR, METAL 10K |
| RV8 | 1-230-846-11 | s | RES, VAR, METAL 100K |
| RV9 | 1-230-842-11 | s | RES, VAR, METAL 5K |
| RV10 | 1-230-845-11 | s | RES, VAR, METAL 50K |

RE-44 BOARD, DVR-1000

| Ref. No. or Qty | Part No. | SP | Description |
|--------------------|--------------|----|--|
| 1pc | A-6017-147-A | o | COMPLETE PCB, RE-44 (This assembly includes the following parts.) |
| C1 | 1-163-038-00 | s | CAP, CHIP, CERAMIC 0.1 50V |
| C2 | 1-163-001-00 | s | CAP, CHIP, CERAMIC 220PF 10% 50V |
| C3 | 1-163-001-00 | s | CAP, CHIP, CERAMIC 220PF 10% 50V |
| CN505F | 1-562-149-11 | o | HOUSING, 4P |
| | 1-563-088-11 | o | CONTACT, FEMALE AWG 24-30 |
| IC1 | 8-759-100-93 | s | IC UPC393G2 |
| PH1 | 1-464-779-21 | s | ENCODER, ROTARY |
| R1 | 1-216-065-00 | s | RES, CHIP, METAL 4.7K 5% 1/10W |
| R2 | 1-216-073-00 | s | RES, CHIP, METAL 10K 5% 1/10W |
| R3 | 1-216-103-00 | s | RES, CHIP, METAL 180K 5% 1/10W |
| R4 | 1-216-065-00 | s | RES, CHIP, METAL 4.7K 5% 1/10W |
| R5 | 1-216-103-00 | s | RES, CHIP, METAL 180K 5% 1/10W |
| R6 | 1-216-065-00 | s | RES, CHIP, METAL 4.7K 5% 1/10W |
| R7 | 1-216-073-00 | s | RES, CHIP, METAL 10K 5% 1/10W |
| R8 | 1-216-065-00 | s | RES, CHIP, METAL 4.7K 5% 1/10W |
| RV1 | 1-228-474-00 | s | RES, VAR, CERMET 10K |
| RV2 | 1-228-474-00 | s | RES, VAR, CERMET 10K |

NOTE: Please see pages D-37 and D-38 for the part numbers of capacitors and resistors that are not listed in the parts list.

RF-15 BOARD, DVR-1000

| Ref. No. or Qty | Part No. | SP | Description |
|--|--------------|----|----------------------------|
| 1pc (This assembly includes the following parts.) | A-6011-114-B | o | COMPLETE PCB, RF-15 |
| 1pc | 3-715-590-01 | o | LABEL, SERIAL NUMBER |
| 2pcs | 3-673-249-00 | o | LEVER, PC BOARD |
| 2pcs | 7-626-320-11 | o | PIN, SPRING 3X8 |
| 4pcs | 7-628-254-30 | s | +PSW, 2.6X10 |
| 2pcs | 7-622-207-05 | s | N 2.6, TYPE 2 |
| 2pcs | 7-622-207-05 | s | N 2.6, TYPE 2 |
| 4pcs | 7-682-647-09 | s | SCREW +PWH 3X6 |
| C9 | 1-131-365-00 | s | CAP, TANT 10uF 20% 20V |
| C10 | 1-131-365-00 | s | CAP, TANT 10uF 20% 20 |
| C11 | 1-131-365-00 | s | CAP, TANT 10uF 20% 20V |
| C12 | 1-131-365-00 | s | CAP, TANT 10uF 20% 20V |
| C13 | 1-131-365-00 | s | CAP, TANT 10uF 20% 20V |
| C26 | 1-109-807-00 | s | CAP, MICA 100PF 1% 100V |
| C27 | 1-109-807-00 | s | CAP, MICA 100PF 1% 100V |
| C28 | 1-109-807-00 | s | CAP, MICA 100PF 1% 100V |
| C29 | 1-109-807-00 | s | CAP, MICA 100PF 1% 100V |
| C81 | 1-130-483-00 | s | CAP, MYLAR 0.01uF 5% 50V |
| C82 | 1-102-110-00 | s | CAP, CERAMIC 220PF 10% 50V |
| CN705M | 1-506-748-11 | s | RECEP, DIN 96P, MALE |
| CN706M | 1-506-746-11 | s | RECEP, DIN 48P, MALE |
| CN740M | 1-506-480-21 | o | RECEP, 15P, MALE |
| CN741M | 1-506-477-11 | o | RECEP, 12P, MALE |
| CN742M | 1-506-477-21 | o | RECEP, 12P, MALE |
| CN743M | 1-506-477-11 | o | RECEP, 12P, MALE |
| CN744M | 1-506-468-11 | o | RECEP, 3P, MALE |
| CN745M | 1-561-310-00 | s | RECEP, RF, MALE |
| CN746M | 1-561-310-00 | s | RECEP, RF, MALE |
| CN747M | 1-561-310-00 | s | RECEP, RF, MALE |
| CN748M | 1-561-310-00 | s | RECEP, RF, MALE |
| D1 | 8-719-400-35 | s | DIODE LN35BP |
| D2 | 8-719-815-55 | s | DIODE 1S1555 |
| D3 | 8-719-815-55 | s | DIODE 1S1555 |
| D4 | 8-719-815-55 | s | DIODE 1S1555 |
| D5 | 8-719-815-55 | s | DIODE 1S1555 |
| D6 | 8-719-815-55 | s | DIODE 1S1555 |
| D7 | 8-719-815-55 | s | DIODE 1S1555 |
| D8 | 8-719-815-55 | s | DIODE 1S1555 |
| D9 | 8-719-815-55 | s | DIODE 1S1555 |
| D10 | 8-719-815-55 | s | DIODE 1S1555 |
| D11 | 8-719-815-55 | s | DIODE 1S1555 |
| D12 | 8-719-815-55 | s | DIODE 1S1555 |
| D13 | 8-719-815-55 | s | DIODE 1S1555 |
| D14 | 8-719-815-55 | s | DIODE 1S1555 |
| D15 | 8-719-815-55 | s | DIODE 1S1555 |
| D16 | 8-719-815-55 | s | DIODE 1S1555 |
| FB1 | 1-535-178-00 | s | FERRITE BEAD |
| FB2 | 1-535-178-00 | s | FERRITE BEAD |
| FB3 | 1-535-178-00 | s | FERRITE BEAD |
| FB4 | 1-535-178-00 | s | FERRITE BEAD |
| FB5 | 1-535-178-00 | s | FERRITE BEAD |
| FB6 | 1-535-178-00 | s | FERRITE BEAD |
| FB7 | 1-535-178-00 | s | FERRITE BEAD |
| FB8 | 1-535-178-00 | s | FERRITE BEAD |
| IC1 | PENDING | s | IC CXA1192 |
| IC2 | PENDING | s | IC CXA1192 |
| IC3 | PENDING | s | IC CXA1192 |
| IC4 | PENDING | s | IC CXA1192 |
| IC5 | PENDING | s | IC CXA1193 |
| IC6 | PENDING | s | IC CXA1193 |
| IC7 | PENDING | s | IC CXA1193 |
| IC8 | PENDING | s | IC CXA1193 |
| IC9 | 8-759-203-08 | s | IC TC74HC221P |
| IC10 | 8-759-203-08 | s | IC TC74HC221P |
| IC11 | 8-759-202-11 | s | IC TC74HC00P |
| IC12 | 8-759-990-84 | s | IC TL084CN |
| IC13 | 8-759-916-29 | s | IC SN74HC74N |
| IC14 | 8-759-301-24 | s | IC HD10124 |
| IC15 | 8-759-301-24 | s | IC HD10124 |
| IC16 | 8-759-007-20 | s | IC MC74HC4052N |
| IC17 | 8-759-007-20 | s | IC MC74HC4052N |

(RF-15 BOARD, DVR-1000)

| Ref. No. or Qty | Part No. | SP | Description |
|--------------------|--------------|----|-------------------------|
| JP1 | 1-566-385-11 | s | PIN, SHORT |
| JP2 | 1-566-385-11 | s | PIN, SHORT |
| JS2 | 1-565-413-11 | s | RECEPTACLE CONNECTOR 2P |
| L1 | 1-421-370-00 | s | COIL, CHOKE |
| L2 | 1-421-370-00 | s | COIL, CHOKE |
| L3 | 1-410-312-11 | s | INDUCTOR, 0.22uH |
| L4 | 1-410-312-11 | s | INDUCTOR, 0.22uH |
| LV1 | 1-410-745-11 | s | INDUCTOR, VAR 0.79uH |
| LV2 | 1-410-745-11 | s | INDUCTOR, VAR 0.79uH |
| LV3 | 1-410-745-11 | s | INDUCTOR, VAR 0.79uH |
| LV4 | 1-410-745-11 | s | INDUCTOR, VAR 0.79uH |
| Q1 | 8-729-606-32 | s | TRANSISTOR 2SC2603-E |
| Q2 | 8-729-173-38 | s | TRANSISTOR 2SA733-K |
| Q3 | 8-729-173-38 | s | TRANSISTOR 2SA733-K |
| Q4 | 8-729-173-38 | s | TRANSISTOR 2SA733-K |
| Q5 | 8-729-173-38 | s | TRANSISTOR 2SA733-K |
| R51 | 1-215-401-11 | s | RES, METAL 150 1% 1/6W |
| R52 | 1-215-401-11 | s | RES, METAL 150 1% 1/6W |
| R53 | 1-215-401-11 | s | RES, METAL 150 1% 1/6W |
| R54 | 1-215-401-11 | s | RES, METAL 150 1% 1/6W |
| R55 | 1-215-401-11 | s | RES, METAL 150 1% 1/6W |
| R56 | 1-215-401-11 | s | RES, METAL 150 1% 1/6W |
| R57 | 1-215-401-11 | s | RES, METAL 150 1% 1/6W |
| R58 | 1-215-401-11 | s | RES, METAL 150 1% 1/6W |
| R104 | 1-215-401-11 | s | RES, METAL 150 1% 1/6W |
| R105 | 1-215-401-11 | s | RES, METAL 150 1% 1/6W |
| R106 | 1-215-401-11 | s | RES, METAL 150 1% 1/6W |
| R107 | 1-215-401-11 | s | RES, METAL 150 1% 1/6W |
| RB1 | 1-231-533-00 | s | RESISTOR BLOCK, 10KX4 |
| RB2 | 1-231-502-00 | s | RESISTOR BLOCK, 510X4 |
| RB3 | 1-231-502-00 | s | RESISTOR BLOCK, 510X4 |
| RV1 | 1-224-940-00 | s | RES, VAR, METAL 10K |
| RV2 | 1-224-940-00 | s | RES, VAR, METAL 10K |
| RV3 | 1-224-942-00 | s | RES, VAR, METAL 50K |
| RV4 | 1-224-942-00 | s | RES, VAR, METAL 50K |
| RV5 | 1-224-942-00 | s | RES, VAR, METAL 50K |
| RV6 | 1-224-942-00 | s | RES, VAR, METAL 50K |
| RV7 | 1-224-924-11 | s | RES, VAR, METAL 500 |
| RV8 | 1-224-924-11 | s | RES, VAR, METAL 500 |
| RV9 | 1-224-924-11 | s | RES, VAR, METAL 500 |
| RV10 | 1-224-924-11 | s | RES, VAR, METAL 500 |
| RV11 | 1-224-942-00 | s | RES, VAR, METAL 50K |
| RV12 | 1-224-942-00 | s | RES, VAR, METAL 50K |
| RV13 | 1-224-942-00 | s | RES, VAR, METAL 50K |
| RV14 | 1-224-942-00 | s | RES, VAR, METAL 50K |

NOTE: Please see pages D-37 and D-38 for the part numbers of capacitors and resistors that are not listed in the parts list.

RS-23 BOARD, DVR-1000

| Ref. No. or Qty | Part No. | SP | Description |
|--------------------|--------------|----|--|
| 1pc | A-6015-105-B | o | COMPLETE PCB, RS-23 (This assembly includes the following parts.) |
| 2pcs | 3-673-249-00 | o | LEVER, PC BOARD |
| 2pcs | 7-626-320-11 | o | PIN, SPRING 3X8 |
| 1pc | 3-715-590-31 | o | LABEL, SERIAL NUMBER |
| 4pcs | 7-628-254-30 | s | +PSW, 2.6X10 |
| 4pcs | 7-622-207-05 | s | N 2.6, TYPE 2 |
| 4pcs | 7-682-647-09 | s | SCREW +PWH 3X6 |
| C3 | 1-162-288-31 | s | CAP, CERAMIC 330PF 10% 50V |
| C4 | 1-124-002-11 | s | CAP, ELECT, NONPOLAR, 1uF 20% 50V |
| C5 | 1-124-259-00 | s | CAP, ELECT 4.7uF 20% 50V |
| C6 | 1-123-611-00 | s | CAP, ELECT 1uF 20% 50V |
| C7 | 1-123-611-00 | s | CAP, ELECT 1uF 20% 50V |
| C8 | 1-124-259-00 | s | CAP, ELECT 4.7uF 20% 50V |
| C9 | 1-130-491-00 | s | CAP, MYLAR 0.047uF 5% 50V |
| C10 | 1-124-259-00 | s | CAP, ELECT 4.7uF 20% 50V |
| C11 | 1-124-259-00 | s | CAP, ELECT 4.7uF 20% 50V |
| C12 | 1-124-598-11 | s | CAP, ELECT 22uF 20% 25V |
| C13 | 1-124-598-11 | s | CAP, ELECT 22uF 20% 25V |
| C14 | 1-124-598-11 | s | CAP, ELECT 22uF 20% 25V |
| C15 | 1-161-379-00 | s | CAP, CERAMIC 0.01uF 20% 25V |
| C17 | 1-124-598-11 | s | CAP, ELECT 22uF 20% 25V |
| C19 | 1-124-598-11 | s | CAP, ELECT 22uF 20% 25V |
| C26 | 1-124-598-11 | s | CAP, ELECT 22uF 20% 25V |
| C27 | 1-124-598-11 | s | CAP, ELECT 22uF 20% 25V |
| C29 | 1-124-259-00 | s | CAP, ELECT 4.7uF 20% 50V |
| C30 | 1-124-236-00 | s | CAP, ELECT 47uF 20% 16V |
| C37 | 1-124-002-11 | s | CAP, ELECT, NONPOLAR, 1uF 20% 50V |
| C38 | 1-130-471-00 | s | CAP, MYLAR 0.001uF 5% 50V |
| C39 | 1-130-477-00 | s | CAP, MYLAR 0.0033uF 5% 50V |
| C40 | 1-162-284-31 | s | CAP, CERAMIC 150PF 10% 50V |
| C41 | 1-162-284-31 | s | CAP, CERAMIC 150PF 10% 50V |
| C42 | 1-162-287-31 | s | CAP, CERAMIC 270PF 10% 50V |
| C43 | 1-130-484-00 | s | CAP, MYLAR 0.012uF 5% 50V |
| C48 | 1-162-294-31 | s | CAP, CERAMIC 0.001uF 10% 50V |
| C53 | 1-124-236-00 | s | CAP, ELECT 47uF 20% 16V |
| C55 | 1-124-236-00 | s | CAP, ELECT 47uF 20% 16V |
| C56 | 1-162-284-31 | s | CAP, CERAMIC 150PF 10% 50V |
| C57 | 1-124-236-00 | s | CAP, ELECT 47uF 20% 16V |
| C59 | 1-162-284-31 | s | CAP, CERAMIC 150PF 10% 50V |
| C60 | 1-162-287-31 | s | CAP, CERAMIC 270PF 10% 50V |
| C61 | 1-124-236-00 | s | CAP, ELECT 47uF 20% 16V |
| C62 | 1-130-484-00 | s | CAP, MYLAR 0.012uF 5% 50V |
| C63 | 1-124-598-11 | s | CAP, ELECT 22uF 20% 25V |
| C64 | 1-123-611-00 | s | CAP, ELECT 1uF 20% 50V |
| C65 | 1-123-611-00 | s | CAP, ELECT 1uF 20% 50V |
| C77 | 1-123-661-00 | s | CAP, ELECT 100uF 20% 6.3V |
| C80 | 1-123-661-00 | s | CAP, ELECT 100uF 20% 6.3V |
| C81 | 1-124-598-11 | s | CAP, ELECT 22uF 20% 25V |
| C82 | 1-124-002-11 | s | CAP, ELECT, NONPOLAR, 1uF 20% 50V |
| C83 | 1-162-814-11 | s | CAP, CERAMIC 0.47uF 10% 50V |
| C84 | 1-162-814-11 | s | CAP, CERAMIC 0.47uF 10% 50V |
| C85 | 1-161-375-00 | s | CAP, CERAMIC 0.0022uF 20% 50V |
| C86 | 1-161-375-00 | s | CAP, CERAMIC 0.0022uF 20% 50V |
| C87 | 1-161-375-00 | s | CAP, CERAMIC 0.0022uF 20% 50V |
| C88 | 1-162-282-31 | s | CAP, CERAMIC 100PF 10% 50V |
| C89 | 1-162-282-31 | s | CAP, CERAMIC 100PF 10% 50V |
| C90 | 1-162-282-31 | s | CAP, CERAMIC 100PF 10% 50V |
| C91 | 1-162-282-31 | s | CAP, CERAMIC 100PF 10% 50V |
| C92 | 1-162-282-31 | s | CAP, CERAMIC 100PF 10% 50V |
| C93 | 1-161-379-00 | s | CAP, CERAMIC 0.01uF 20% 25V |
| CN1M | 1-560-313-00 | o | RECEP, IL 8P, MALE |
| CN720M | 1-506-748-11 | s | RECEP, DIN 96P, MALE |
| CN721M | 1-506-746-11 | s | RECEP, DIN 48P, MALE |
| D1 | 8-719-911-06 | s | DIODE 1SS106 |
| D2 | 8-719-911-06 | s | DIODE 1SS106 |
| D3 | 8-719-101-98 | s | DIODE 1SS97 |
| D4 | 8-719-101-98 | s | DIODE 1SS97 |
| D5 | 8-719-101-98 | s | DIODE 1SS97 |
| D6 | 8-719-101-98 | s | DIODE 1SS97 |
| D7 | 1-807-200-11 | s | DIODE S5277B |
| D8 | 8-719-933-30 | s | DIODE DA210S |
| D9 | 8-719-933-30 | s | DIODE DA210S |
| D10 | 8-719-933-30 | s | DIODE DA210S |

(RS-23 BOARD, DVR-1000)

| Ref. No. or Qty | Part No. | SP | Description |
|--------------------|--------------|----|------------------------------|
| FB1 | 1-535-178-00 | s | FERRITE BEAD |
| ICA1 | 8-759-990-82 | s | IC TL082CP |
| ICA2 | 8-759-000-47 | s | IC MC14051BCP |
| ICA3 | 8-759-000-47 | s | IC MC14051BCP |
| ICA4 | 8-759-000-47 | s | IC MC14051BCP |
| ICA5 | 8-759-000-47 | s | IC MC14051BCP |
| ICA6 | 8-759-000-47 | s | IC MC14051BCP |
| ICA7 | 8-759-135-80 | s | IC uPC358C |
| ICA8 | 8-759-990-82 | s | IC TL082CP |
| ICA9 | 8-759-103-95 | s | IC uPC48C |
| ICA11 | 8-759-917-05 | s | IC SN74HC541N |
| ICA12 | 8-759-107-52 | s | IC CXQ71054P |
| ICA14 | 8-759-112-54 | s | IC uPD78C10G-36 |
| ICA17 | 8-759-741-10 | s | IC MBM27C32A-RS230120 |
| ICA19 | 8-759-916-94 | s | IC SN74HC373N |
| ICB1 | 8-759-990-82 | s | IC TL082CP |
| ICB2 | 8-759-103-93 | s | IC uPC393C |
| ICB3 | 8-759-135-80 | s | IC uPC358C |
| ICB4 | 8-759-135-80 | s | IC uPC358C |
| ICB5 | 8-759-135-80 | s | IC uPC358C |
| ICB6 | 8-759-135-80 | s | IC uPC358C |
| ICB7 | 8-759-000-47 | s | IC MC14051BCP |
| ICC5 | 8-759-240-53 | s | IC TC4053BP |
| ICC6 | 8-759-135-80 | s | IC uPC358C |
| ICC11 | 8-759-302-76 | s | IC HM6116ALSP-15 |
| ICC17 | 8-759-921-34 | s | IC SN74HC245N |
| ICC18 | 8-759-203-36 | s | IC TC74HC374P |
| ICD1 | 8-759-990-82 | s | IC TL082CP |
| ICD2 | 8-759-135-80 | s | IC uPC358C |
| ICD3 | 8-759-103-93 | s | IC uPC393C |
| ICD4 | 8-759-135-80 | s | IC uPC358C |
| ICD6 | 8-759-990-82 | s | IC TL082CP |
| ICD7 | 8-759-990-82 | s | IC TL082CP |
| ICD8 | 8-759-202-74 | s | IC TC74HC04P |
| ICD9 | 8-759-203-68 | s | IC TC74HC4040P |
| ICD10 | 8-759-202-74 | s | IC TC74HC04P |
| ICD12 | 8-759-916-29 | s | IC SN74HC74N |
| ICD13 | 8-759-910-43 | s | IC CX23028 |
| ICE1 | 8-759-990-82 | s | IC TL082CP |
| ICE2 | 8-759-202-74 | s | IC TC74HC04P |
| ICE3 | 8-759-103-93 | s | IC uPC393C |
| ICE4 | 8-759-135-80 | s | IC uPC358C |
| ICE5 | 8-759-240-52 | s | IC TC4052BP |
| ICE6 | 8-759-990-82 | s | IC TL082CP |
| ICE7 | 8-759-990-82 | s | IC TL082CP |
| ICE8 | 8-759-921-34 | s | IC SN74HC245N |
| ICE9 | 8-759-916-50 | s | IC SN74HC157N |
| ICE10 | 8-759-916-50 | s | IC SN74HC157N |
| ICE11 | 8-759-916-50 | s | IC SN74HC157N |
| ICE12 | 8-759-202-21 | s | IC TC74HC32P |
| ICE13 | 8-759-202-11 | s | IC TC74HC00P |
| ICE14 | 8-759-803-70 | s | IC LC74HC08 |
| ICE15 | 8-759-202-21 | s | IC TC74HC32P |
| ICE16 | 8-759-917-05 | s | IC SN74HC541N |
| ICE17 | 8-759-916-79 | s | IC SN74HC273N |
| L1 | 1-421-329-00 | s | COIL, CHOKE |
| L2 | 1-421-329-00 | s | COIL, CHOKE |
| L3 | 1-421-329-00 | s | COIL, CHOKE |
| L4 | 1-421-329-00 | s | COIL, CHOKE |
| Q1 | 8-759-937-22 | s | IC BA707 |
| Q2 | 8-729-801-83 | s | TRANSISTOR 2SB1013 |
| Q3 | 8-729-801-83 | s | TRANSISTOR 2SB1013 |
| Q4 | 8-729-900-36 | s | TRANSISTOR DTC124ES |
| Q5 | 8-729-900-36 | s | TRANSISTOR DTC124ES |
| Q6 | 8-729-900-36 | s | TRANSISTOR DTC124ES |
| R3 | 1-249-420-11 | s | RES, CARBON 1.8K 5% 1/6W |
| R6 | 1-249-434-11 | s | RES, CARBON 27K 5% 1/6W |
| R7 | 1-249-411-11 | s | RES, CARBON 330 5% 1/6W |
| R8 | 1-249-429-11 | s | RES, CARBON 10K 5% 1/6W |
| R9 | 1-249-411-11 | s | RES, RES, CARBON 330 5% 1/6W |

NOTE: Please see pages D-37 and D-38 for the part numbers of capacitors and resistors that are not listed in the parts list.

(RS-23 BOARD, DVR-1000)

| Ref. No. or Qty | Part No. | SP | Description |
|--------------------|--------------|----|--------------------------|
| R10 | 1-249-429-11 | s | RES. CARBON 10K 5% 1/6W |
| R11 | 1-249-429-11 | s | RES. CARBON 10K 5% 1/6W |
| R12 | 1-249-441-11 | s | RES. CARBON 100K 5% 1/6W |
| R13 | 1-249-437-11 | s | RES. CARBON 47K 5% 1/6W |
| R14 | 1-249-441-11 | s | RES. CARBON 100K 5% 1/6W |
| R15 | 1-249-437-11 | s | RES. CARBON 47K 5% 1/6W |
| R16 | 1-249-441-11 | s | RES. CARBON 100K 5% 1/6W |
| R17 | 1-249-437-11 | s | RES. CARBON 47K 5% 1/6W |
| R18 | 1-249-441-11 | s | RES. CARBON 100K 5% 1/6W |
| R19 | 1-249-429-11 | s | RES. CARBON 10K 5% 1/6W |
| R20 | 1-249-441-11 | s | RES. CARBON 100K 5% 1/6W |
| R21 | 1-249-437-11 | s | RES. CARBON 47K 5% 1/6W |
| R22 | 1-249-429-11 | s | RES. CARBON 10K 5% 1/6W |
| R23 | 1-249-416-11 | s | RES. CARBON 820 5% 1/6W |
| R24 | 1-249-435-11 | s | RES. CARBON 33K 5% 1/6W |
| R25 | 1-249-417-11 | s | RES. CARBON 1K 5% 1/6W |
| R27 | 1-249-425-11 | s | RES. CARBON 4.7K 5% 1/6W |
| R28 | 1-249-429-11 | s | RES. CARBON 10K 5% 1/6W |
| R29 | 1-249-429-11 | s | RES. CARBON 10K 5% 1/6W |
| R30 | 1-249-429-11 | s | RES. CARBON 10K 5% 1/6W |
| R31 | 1-249-429-11 | s | RES. CARBON 10K 5% 1/6W |
| R33 | 1-249-425-11 | s | RES. CARBON 4.7K 5% 1/6W |
| R40 | 1-249-437-11 | s | RES. CARBON 47K 5% 1/6W |
| R41 | 1-249-405-11 | s | RES. CARBON 100 5% 1/6W |
| R43 | 1-249-429-11 | s | RES. CARBON 10K 5% 1/6W |
| R44 | 1-249-429-11 | s | RES. CARBON 10K 5% 1/6W |
| R45 | 1-249-437-11 | s | RES. CARBON 47K 5% 1/6W |
| R46 | 1-249-437-11 | s | RES. CARBON 47K 5% 1/6W |
| R47 | 1-249-437-11 | s | RES. CARBON 47K 5% 1/6W |
| R51 | 1-249-425-11 | s | RES. CARBON 4.7K 5% 1/6W |
| R52 | 1-249-411-11 | s | RES. CARBON 330 5% 1/6W |
| R53 | 1-249-429-11 | s | RES. CARBON 10K 5% 1/6W |
| R54 | 1-249-415-11 | s | RES. CARBON 680 5% 1/6W |
| R57 | 1-249-411-11 | s | RES. CARBON 330 5% 1/6W |
| R58 | 1-249-411-11 | s | RES. CARBON 330 5% 1/6W |
| R59 | 1-249-429-11 | s | RES. CARBON 10K 5% 1/6W |
| R60 | 1-249-411-11 | s | RES. CARBON 330 5% 1/6W |
| R61 | 1-249-425-11 | s | RES. CARBON 4.7K 5% 1/6W |
| R62 | 1-249-437-11 | s | RES. CARBON 47K 5% 1/6W |
| R63 | 1-249-393-11 | s | RES. CARBON 10 5% 1/6W |
| R64 | 1-249-437-11 | s | RES. CARBON 47K 5% 1/6W |
| R65 | 1-249-393-11 | s | RES. CARBON 10 5% 1/6W |
| R66 | 1-249-429-11 | s | RES. CARBON 10K 5% 1/6W |
| R67 | 1-249-429-11 | s | RES. CARBON 10K 5% 1/6W |
| R68 | 1-249-411-11 | s | RES. CARBON 330 5% 1/6W |
| R69 | 1-249-411-11 | s | RES. CARBON 330 5% 1/6W |
| R70 | 1-249-411-11 | s | RES. CARBON 330 5% 1/6W |
| R76 | 1-249-420-11 | s | RES. CARBON 1.8K 5% 1/6W |
| R81 | 1-249-429-11 | s | RES. CARBON 10K 5% 1/6W |
| R83 | 1-249-429-11 | s | RES. CARBON 10K 5% 1/6W |
| R89 | 1-249-429-11 | s | RES. CARBON 10K 5% 1/6W |
| R91 | 1-249-429-11 | s | RES. CARBON 10K 5% 1/6W |
| R96 | 1-249-431-11 | s | RES. CARBON 15K 5% 1/6W |
| R99 | 1-249-433-11 | s | RES. CARBON 22K 5% 1/6W |
| R100 | 1-249-435-11 | s | RES. CARBON 33K 5% 1/6W |
| R101 | 1-249-411-11 | s | RES. CARBON 330 5% 1/6W |
| R102 | 1-249-435-11 | s | RES. CARBON 33K 5% 1/6W |
| R103 | 1-249-411-11 | s | RES. CARBON 330 5% 1/6W |
| R104 | 1-249-433-11 | s | RES. CARBON 22K 5% 1/6W |
| R105 | 1-249-433-11 | s | RES. CARBON 22K 5% 1/6W |
| R106 | 1-249-393-11 | s | RES. CARBON 10 5% 1/6W |
| R107 | 1-249-435-11 | s | RES. CARBON 33K 5% 1/6W |
| R108 | 1-249-411-11 | s | RES. CARBON 330 5% 1/6W |
| R109 | 1-249-433-11 | s | RES. CARBON 22K 5% 1/6W |
| R110 | 1-249-435-11 | s | RES. CARBON 33K 5% 1/6W |
| R111 | 1-249-429-11 | s | RES. CARBON 10K 5% 1/6W |
| R112 | 1-249-429-11 | s | RES. CARBON 10K 5% 1/6W |
| R113 | 1-249-429-11 | s | RES. CARBON 10K 5% 1/6W |
| R114 | 1-249-429-11 | s | RES. CARBON 10K 5% 1/6W |
| R115 | 1-249-429-11 | s | RES. CARBON 10K 5% 1/6W |

(RS-23 BOARD, DVR-1000)

| Ref. No. or Qty | Part No. | SP | Description |
|--------------------|--------------|----|--------------------------|
| R116 | 1-249-437-11 | s | RES. CARBON 47K 5% 1/6W |
| R117 | 1-249-437-11 | s | RES. CARBON 47K 5% 1/6W |
| R118 | 1-249-393-11 | s | RES. CARBON 10 5% 1/6W |
| R120 | 1-249-429-11 | s | RES. CARBON 10K 5% 1/6W |
| R121 | 1-249-429-11 | s | RES. CARBON 10K 5% 1/6W |
| R122 | 1-249-429-11 | s | RES. CARBON 10K 5% 1/6W |
| R123 | 1-249-437-11 | s | RES. CARBON 47K 5% 1/6W |
| R124 | 1-249-437-11 | s | RES. CARBON 47K 5% 1/6W |
| R125 | 1-249-393-11 | s | RES. CARBON 10 5% 1/6W |
| R126 | 1-249-393-11 | s | RES. CARBON 10 5% 1/6W |
| R127 | 1-249-411-11 | s | RES. CARBON 330 5% 1/6W |
| R128 | 1-249-411-11 | s | RES. CARBON 330 5% 1/6W |
| R129 | 1-249-393-11 | s | RES. CARBON 10 5% 1/6W |
| R130 | 1-249-393-11 | s | RES. CARBON 10 5% 1/6W |
| R131 | 1-249-421-11 | s | RES. CARBON 2.2K 5% 1/6W |
| R132 | 1-249-429-11 | s | RES. CARBON 10K 5% 1/6W |
| R133 | 1-249-411-11 | s | RES. CARBON 330 5% 1/6W |
| R134 | 1-249-423-11 | s | RES. CARBON 3.3K 5% 1/6W |
| R135 | 1-249-429-11 | s | RES. CARBON 10K 5% 1/6W |
| R136 | 1-249-429-11 | s | RES. CARBON 10K 5% 1/6W |
| R137 | 1-249-429-11 | s | RES. CARBON 10K 5% 1/6W |
| R139 | 1-249-413-11 | s | RES. CARBON 470 5% 1/6W |
| R140 | 1-249-413-11 | s | RES. CARBON 470 5% 1/6W |
| R143 | 1-249-429-11 | s | RES. CARBON 10K 5% 1/6W |
| R144 | 1-249-429-11 | s | RES. CARBON 10K 5% 1/6W |
| R156 | 1-249-393-11 | s | RES. CARBON 10 5% 1/6W |
| R157 | 1-249-425-11 | s | RES. CARBON 4.7K 5% 1/6W |
| R159 | 1-249-441-11 | s | RES. CARBON 100K 5% 1/6W |
| R160 | 1-249-441-11 | s | RES. CARBON 100K 5% 1/6W |
| R161 | 1-249-441-11 | s | RES. CARBON 100K 5% 1/6W |
| R162 | 1-249-441-11 | s | RES. CARBON 100K 5% 1/6W |
| R163 | 1-249-441-11 | s | RES. CARBON 100K 5% 1/6W |
| R164 | 1-249-441-11 | s | RES. CARBON 100K 5% 1/6W |
| R165 | 1-249-441-11 | s | RES. CARBON 100K 5% 1/6W |
| R166 | 1-249-441-11 | s | RES. CARBON 100K 5% 1/6W |
| R171 | 1-249-411-11 | s | RES. CARBON 330 5% 1/6W |
| R172 | 1-249-411-11 | s | RES. CARBON 330 5% 1/6W |
| R173 | 1-249-411-11 | s | RES. CARBON 330 5% 1/6W |
| R174 | 1-249-411-11 | s | RES. CARBON 330 5% 1/6W |
| R175 | 1-249-411-11 | s | RES. CARBON 330 5% 1/6W |
| R176 | 1-249-393-11 | s | RES. CARBON 10 5% 1/6W |
| R177 | 1-249-393-11 | s | RES. CARBON 10 5% 1/6W |
| R178 | 1-249-431-11 | s | RES. CARBON 15K 5% 1/6W |
| R179 | 1-249-429-11 | s | RES. CARBON 10K 5% 1/6W |
| R180 | 1-247-849-00 | s | RES. CARBON 5.6K 5% 1/6W |
| R181 | 1-249-425-11 | s | RES. CARBON 4.7K 5% 1/6W |
| R182 | 1-249-425-11 | s | RES. CARBON 4.7K 5% 1/6W |
| R183 | 1-249-425-11 | s | RES. CARBON 4.7K 5% 1/6W |
| R184 | 1-249-425-11 | s | RES. CARBON 4.7K 5% 1/6W |
| R185 | 1-249-441-11 | s | RES. CARBON 100K 5% 1/6W |
| R186 | 1-249-425-11 | s | RES. CARBON 4.7K 5% 1/6W |
| R187 | 1-249-425-11 | s | RES. CARBON 4.7K 5% 1/6W |
| R188 | 1-249-441-11 | s | RES. CARBON 100K 5% 1/6W |
| R192 | 1-249-439-11 | s | RES. CARBON 68K 5% 1/6W |
| R193 | 1-249-438-11 | s | RES. CARBON 56K 5% 1/6W |
| R195 | 1-249-429-11 | s | RES. CARBON 10K 5% 1/6W |
| R196 | 1-249-429-11 | s | RES. CARBON 10K 5% 1/6W |
| RB1 | 1-231-567-00 | s | RESISTOR BLOCK, 10KX2 |
| RB2 | 1-231-567-00 | s | RESISTOR BLOCK, 10KX2 |
| RB3 | 1-235-005-00 | s | RESISTOR BLOCK, 47KX8 |
| RV1 | 1-230-844-11 | s | RES. VAR. METAL 20K |
| RV2 | 1-230-840-11 | s | RES. VAR. METAL 1K |
| RV3 | 1-230-842-11 | s | RES. VAR. METAL 5K |

NOTE: Please see pages D-37 and D-38 for the part numbers of capacitors and resistors that are not listed in the parts list.

SE-47 BOARD, DVR-1000

| Ref. No. or Qty | Part No. | SP | Description |
|--------------------|--------------|----|--|
| 1pc | A-6025-112-A | o | COMPLETE PCB, SE-47 (This assembly includes the following parts.) |
| 1pc | 7-682-647-09 | s | SCREW +PWH 3X6 |
| C19 | 1-123-661-00 | s | CAP, ELECT 100uF 20% 6.3V |
| CN301M | 1-506-483-21 | o | RECEP, 4P, MALE |
| CN302M | 1-506-489-11 | o | RECEP, 10P, MALE |
| CN303M | 1-506-487-11 | o | RECEP, 8P, MALE |
| CN304M | 1-506-485-11 | o | RECEP, 6P, MALE |
| CN305M | 1-506-485-21 | o | RECEP, 6P, MALE |
| CN306M | 1-506-485-31 | o | RECEP, 6P, MALE |
| CN307M | 1-506-485-41 | o | RECEP, 6P, MALE |
| CN308M | 1-506-487-11 | o | RECEP, 8P, MALE |
| IC1 | 8-759-925-26 | s | IC CX23026 |
| IC2 | 8-759-925-26 | s | IC CX23026 |
| IC3 | 8-759-925-26 | s | IC CX23026 |
| IC4 | 8-759-045-84 | s | IC MC14584BCP |
| IC5 | 8-759-045-84 | s | IC MC14584BCP |
| IC6 | 8-759-045-84 | s | IC MC14584BCP |
| L1 | 1-421-329-00 | s | COIL, CHOKE |
| Q1 | 8-729-900-80 | s | TRANSISTOR DTC114ES |
| Q2 | 8-729-900-80 | s | TRANSISTOR DTC114ES |
| Q3 | 8-729-900-80 | s | TRANSISTOR DTC114ES |
| Q4 | 8-729-900-80 | s | TRANSISTOR DTC114ES |
| R9 | 1-249-410-11 | s | RES, CARBON 270 5% 1/6W |
| R10 | 1-249-410-11 | s | RES, CARBON 270 5% 1/6W |
| R11 | 1-249-410-11 | s | RES, CARBON 270 5% 1/6W |
| R12 | 1-249-410-11 | s | RES, CARBON 270 5% 1/6W |
| R13 | 1-249-413-11 | s | RES, CARBON 470 5% 1/6W |
| R14 | 1-249-413-11 | s | RES, CARBON 470 5% 1/6W |
| R15 | 1-249-413-11 | s | RES, CARBON 470 5% 1/6W |
| R16 | 1-249-413-11 | s | RES, CARBON 470 5% 1/6W |
| R20 | 1-249-413-11 | s | RES, CARBON 470 5% 1/6W |
| R21 | 1-249-413-11 | s | RES, CARBON 470 5% 1/6W |
| R26 | 1-249-433-11 | s | RES, CARBON 22K 5% 1/6W |
| R28 | 1-249-429-11 | s | RES, CARBON 10K 5% 1/4W |
| RB1 | 1-231-411-00 | s | RESISTOR BLOCK, 100KX8 |
| RB2 | 1-231-557-00 | s | RESISTOR BLOCK, 100KX4 |
| RB3 | 1-231-541-00 | s | RESISTOR BLOCK, 22KX4 |

SP-01 BOARD, DVR-1000

| Ref. No. or Qty | Part No. | SP | Description |
|--------------------|--------------|----|--|
| 1pc | A-6017-140-A | o | COMPLETE PCB, SP-01 (This assembly includes the following parts.) |
| 2pcs | 3-673-249-00 | o | LEVER, PC BOARD |
| 2pcs | 7-626-320-11 | o | PIN, SPRING 3X8 |
| 4pcs | 7-622-207-05 | s | N 2.6, TYPE 2 |
| 1pc | 7-628-254-30 | s | +PSW, 2.6X10 |
| 1pc | 3-715-590-41 | o | LABEL, SERIAL NUMBER |
| 2pcs | 7-621-255-65 | s | SCREW +B 2X10 |
| 2pcs | 7-622-205-05 | s | NUT M2, TYPE2 |
| 3pcs | 7-628-254-30 | s | +PSW, 2.6X10 |
| 4pcs | 7-682-647-09 | s | SCREW +PWH 3X6 |
| C1 | 1-123-661-00 | s | CAP, ELECT 100uF 20% 6.3V |
| C9 | 1-125-390-11 | s | CAP, CERAMIC 0.047F 5V 5V |
| C11 | 1-131-347-00 | s | CAP, TANT 1uF 10% 35V |
| C13 | 1-131-347-00 | s | CAP, TANT 1uF 10% 35V |
| C22 | 1-123-661-00 | s | CAP, ELECT 100uF 20% 6.3V |
| C26 | 1-162-294-31 | s | CAP, CERAMIC 0.001uF 10% 50V |
| C32 | 1-130-491-00 | s | CAP, MYLAR 0.047uF 5% 50V |
| C56 | 1-123-661-00 | s | CAP, ELECT 100uF 20% 6.3V |
| C59 | 1-123-661-00 | s | CAP, ELECT 100uF 20% 6.3V |
| C60 | 1-130-483-00 | s | CAP, MYLAR 0.01uF 5% 50V |
| CN1F | 1-563-339-11 | o | RECEP, 48P, FEMALE |
| CN722M | 1-506-748-11 | s | RECEP, DIN 96P, MALE |
| CN723M | 1-506-746-11 | s | RECEP, DIN 48P, MALE |
| D1 | 8-719-400-35 | s | DIODE LN35BP |
| D2 | 8-719-908-06 | s | DIODE ERA81-005 |
| FB1 | 1-535-178-00 | s | FERRITE BEAD |
| ICA2 | 8-759-916-29 | s | IC SN74HC74N |
| ICA3 | 8-759-916-29 | s | IC SN74HC74N |
| ICA4 | 8-759-921-08 | s | IC SN74HC02N |
| ICA5 | 8-759-916-20 | s | IC SN74HC14N |
| ICA6 | 8-759-916-12 | s | IC SN74HC00N |
| ICA7 | 8-759-916-14 | s | IC SN74HC04N |
| ICA8 | 8-759-916-12 | s | IC SN74HC00N |
| ICA23 | 8-759-917-43 | s | IC SN74HC138N |
| ICB4 | 8-759-916-29 | s | IC SN74HC74N |
| ICB5 | 8-759-916-12 | s | IC SN74HC00N |
| ICB6 | 8-759-921-19 | s | IC SN74HC161N |
| ICB7 | 8-759-916-29 | s | IC SN74HC74N |
| ICB8 | 8-759-916-14 | s | IC SN74HC04N |
| ICB10 | 8-759-102-95 | s | IC uPD4464C-15 |
| ICB13 | 8-759-733-69 | s | IC MBM27C256A-SP010130 |
| ICB15 | 8-759-105-76 | s | IC uPD71059C |
| ICB17 | 8-759-921-50 | s | IC SN74HC573N |
| ICB18 | 8-759-105-75 | s | IC uPD70108D-8 |
| ICB21 | 8-759-916-46 | s | IC SN74HC139N |
| ICB22 | 8-759-916-19 | s | IC SN74HC11N |
| ICB23 | 8-759-916-14 | s | IC SN74HC04N |
| ICC1 | 8-759-917-05 | s | IC SN74HC541N |
| ICC2 | 8-759-917-05 | s | IC SN74HC541N |
| ICC3 | 8-759-916-79 | s | IC SN74HC273N |
| ICC4 | 8-759-921-19 | s | IC SN74HC161N |
| ICC5 | 8-759-916-29 | s | IC SN74HC74N |
| ICC7 | 8-759-925-26 | s | IC CX23026 |
| ICC8 | 8-759-925-26 | s | IC CX23026 |
| ICC9 | 8-759-925-26 | s | IC CX23026 |
| ICC10 | 8-759-925-26 | s | IC CX23026 |
| ICC11 | 8-759-916-50 | s | IC SN74HC157N |
| ICC12 | 8-759-917-43 | s | IC SN74HC138N |
| ICC13 | 8-759-917-43 | s | IC SN74HC138N |
| ICC14 | 8-759-038-14 | s | IC MC74HC4538AN |
| ICC16 | 8-759-803-70 | s | IC LC74HC08 |
| ICC17 | 8-759-921-34 | s | IC SN74HC245N |
| ICC19 | 8-759-107-56 | s | IC CXQ71011P |
| ICC20 | 8-759-916-29 | s | IC SN74HC74N |
| ICC21 | 8-759-916-29 | s | IC SN74HC74N |
| ICC22 | 8-759-916-35 | s | IC SN74HC107N |
| ICC23 | 8-759-921-19 | s | IC SN74HC161N |
| ICD1 | 8-759-107-52 | s | IC CXQ71054P |
| ICD3 | 8-759-107-52 | s | IC CXQ71054P |
| ICD5 | 8-759-917-05 | s | IC SN74HC541N |
| ICD6 | 8-759-916-79 | s | IC SN74HC273N |

NOTE: Please see pages D-37 and D-38 for the part numbers of capacitors and resistors that are not listed in the parts list.

(SP-01 BOARD, DVR-1000)

| Ref. No. or Qty | Part No. | SP | Description |
|--------------------|--------------|----|--------------------------|
| ICD7 | 8-759-925-26 | s | IC CX23026 |
| ICD8 | 8-759-925-26 | s | IC CX23026 |
| ICD9 | 8-759-925-26 | s | IC CX23026 |
| ICD10 | 8-759-925-26 | s | IC CX23026 |
| ICD11 | 8-759-925-26 | s | IC CX23026 |
| ICD12 | 8-759-921-34 | s | IC SN74HC245N |
| ICD13 | 8-759-921-50 | s | IC SN74HC573N |
| ICD14 | 8-759-921-34 | s | IC SN74HC245N |
| ICD15 | 8-759-917-43 | s | IC SN74HC138N |
| ICD16 | 8-759-917-43 | s | IC SN74HC138N |
| ICD17 | 8-759-917-05 | s | IC SN74HC541N |
| ICD19 | 8-759-917-05 | s | IC SN74HC541N |
| ICD20 | 8-759-916-71 | s | IC SN74HC244N |
| ICD21 | 8-759-921-17 | s | IC SN74HC153N |
| ICD23 | 8-759-916-25 | s | IC SN74HC32N |
| L1 | 1-421-329-00 | s | COIL, CHOKE |
| Q1 | 8-729-900-37 | s | TRANSISTOR DTC124EF |
| Q2 | 8-729-900-37 | s | TRANSISTOR DTC124EF |
| Q3 | 8-729-900-37 | s | TRANSISTOR DTC124EF |
| Q4 | 8-729-900-37 | s | TRANSISTOR DTC124EF |
| R1 | 1-249-409-11 | s | RES, CARBON 220 5% 1/6W |
| R2 | 1-249-437-11 | s | RES, CARBON 47K 5% 1/6W |
| R3 | 1-249-437-11 | s | RES, CARBON 47K 5% 1/6W |
| R4 | 1-249-417-11 | s | RES, CARBON 1K 5% 1/6W |
| R5 | 1-249-437-11 | s | RES, CARBON 47K 5% 1/6W |
| R6 | 1-249-405-11 | s | RES, CARBON 100 5% 1/6W |
| R7 | 1-249-437-11 | s | RES, CARBON 47K 5% 1/6W |
| R8 | 1-249-425-11 | s | RES, CARBON 4.7K 5% 1/6W |
| R10 | 1-249-393-11 | s | RES, CARBON 10 5% 1/6W |
| R11 | 1-249-411-11 | s | RES, CARBON 330 5% 1/6W |
| R12 | 1-249-421-11 | s | RES, CARBON 2.2K 5% 1/6W |
| R13 | 1-249-437-11 | s | RES, CARBON 47K 5% 1/6W |
| R14 | 1-249-425-11 | s | RES, CARBON 4.7K 5% 1/6W |
| R15 | 1-249-437-11 | s | RES, CARBON 47K 5% 1/6W |
| R16 | 1-249-429-11 | s | RES, CARBON 10K 5% 1/6W |
| R18 | 1-249-393-11 | s | RES, CARBON 10 5% 1/6W |
| R19 | 1-249-417-11 | s | RES, CARBON 1K 5% 1/6W |
| R20 | 1-249-429-11 | s | RES, CARBON 10K 5% 1/6W |
| R29 | 1-249-437-11 | s | RES, CARBON 47K 5% 1/6W |
| R30 | 1-249-405-11 | s | RES, CARBON 100 5% 1/6W |
| R35 | 1-249-393-11 | s | RES, CARBON 10 5% 1/6W |
| R36 | 1-249-393-11 | s | RES, CARBON 10 5% 1/6W |
| R37 | 1-249-437-11 | s | RES, CARBON 47K 5% 1/6W |
| R38 | 1-214-557-00 | s | RES, METAL 1K 1% 1/8W |
| RB1 | 1-235-005-00 | s | RESISTOR BLOCK, 47KX8 |
| RB2 | 1-235-005-00 | s | RESISTOR BLOCK, 47KX8 |
| RB3 | 1-235-005-00 | s | RESISTOR BLOCK, 47KX8 |
| RB4 | 1-235-005-00 | s | RESISTOR BLOCK, 47KX8 |
| RB5 | 1-235-005-00 | s | RESISTOR BLOCK, 47KX8 |
| RB6 | 1-235-005-00 | s | RESISTOR BLOCK, 47KX8 |
| RB7 | 1-235-005-00 | s | RESISTOR BLOCK, 47KX8 |
| RB8 | 1-235-005-00 | s | RESISTOR BLOCK, 47KX8 |
| RB9 | 1-235-005-00 | s | RESISTOR BLOCK, 47KX8 |
| S1 | 1-553-856-00 | s | SWITCH, PUSH |
| S2 | 1-553-856-00 | s | SWITCH, PUSH |
| S3 | 1-554-397-21 | s | SWITCH, TOGGLE |
| X1 | 1-567-798-12 | s | CRYSTAL 14.74560000MHZ |

SW-157 BOARD, DVR-1000

| Ref. No. or Qty | Part No. | SP | Description |
|--------------------|--------------|----|---|
| ipc | A-6017-143-A | o | COMPLETE PCB, SW-157 (This assembly includes the following parts.) |
| 4pcs | 3-674-390-00 | o | HOLDER (B), LED |
| 2pcs | 7-682-647-09 | s | SCREW +PWH 3X6 |
| C3 | 1-123-661-00 | s | CAP, ELECT 100uF 20% 6.3V |
| C4 | 1-123-661-00 | s | CAP, ELECT 100uF 20% 6.3V |
| C5 | 1-136-165-00 | s | CAP, MYLAR 0.1uF 10% 50V |
| C6 | 1-123-661-00 | s | CAP, ELECT 100uF 20% 6.3V |
| C7 | 1-123-661-00 | s | CAP, ELECT 100uF 20% 6.3V |
| C8 | 1-123-661-00 | s | CAP, ELECT 100uF 20% 6.3V |
| C11 | 1-102-110-00 | s | CAP, CERAMIC 220PF 10% 50V |
| C15 | 1-124-242-00 | s | CAP, ELECT 33uF 20% 25V |
| C17 | 1-123-661-00 | s | CAP, ELECT 100uF 20% 6.3V |
| C19 | 1-102-106-00 | s | CAP, CERAMIC 100PF 10% 50V |
| C20 | 1-102-106-00 | s | CAP, CERAMIC 100PF 10% 50V |
| C21 | 1-102-106-00 | s | CAP, CERAMIC 100PF 10% 50V |
| C22 | 1-102-106-00 | s | CAP, CERAMIC 100PF 10% 50V |
| C23 | 1-102-106-00 | s | CAP, CERAMIC 100PF 10% 50V |
| C24 | 1-102-106-00 | s | CAP, CERAMIC 100PF 10% 50V |
| C25 | 1-102-106-00 | s | CAP, CERAMIC 100PF 10% 50V |
| C26 | 1-102-106-00 | s | CAP, CERAMIC 100PF 10% 50V |
| C27 | 1-161-485-00 | s | CAP, CERAMIC 0.1uF 10% 50V |
| C28 | 1-161-485-00 | s | CAP, CERAMIC 0.1uF 10% 50V |
| C29 | 1-131-386-00 | s | CAP, TANT 33uF 10% 6.3V |
| CN502M | 1-566-405-21 | o | RECEP, 30P, MALE |
| CN503M | 1-566-398-21 | o | RECEP, 16P, MALE |
| CN504M | 1-506-478-11 | o | RECEP, 13P, MALE |
| CN505M | 1-506-483-21 | o | RECEP, 4P, MALE |
| CN506M | 1-506-485-11 | o | RECEP, 6P, MALE |
| CN507M | 1-566-402-11 | o | RECEP, 24P, MALE |
| D1 | 8-719-918-88 | s | DIODE 1SS198 |
| D2 | 8-719-918-88 | s | DIODE 1SS198 |
| D3 | 8-719-918-88 | s | DIODE 1SS198 |
| D4 | 8-719-918-88 | s | DIODE 1SS198 |
| D5 | 8-719-918-88 | s | DIODE 1SS198 |
| D6 | 8-719-918-88 | s | DIODE 1SS198 |
| D7 | 8-719-918-88 | s | DIODE 1SS198 |
| D8 | 8-719-918-88 | s | DIODE 1SS198 |
| D9 | 8-719-918-88 | s | DIODE 1SS198 |
| D10 | 8-719-918-88 | s | DIODE 1SS198 |
| D11 | 8-719-918-88 | s | DIODE 1SS198 |
| D12 | 8-719-918-88 | s | DIODE 1SS198 |
| D13 | 8-719-905-55 | s | DIODE EAA5504S |
| D14 | 8-719-905-56 | s | DIODE EBR5504S |
| D15 | 8-719-905-56 | s | DIODE EBR5504S |
| D16 | 8-719-905-54 | s | DIODE EBG5504S |
| IC1 | 8-759-909-59 | s | IC SN76489AN |
| IC2 | 8-759-208-50 | s | IC TA7368P |
| IC3 | 8-759-938-68 | s | IC CXD1095Q |
| IC4 | 8-759-910-43 | s | IC CX23028 |
| IC5 | 8-759-938-68 | s | IC CXD1095Q |
| IC6 | 8-759-205-00 | s | IC TC74HC14F |
| IC7 | 8-759-011-90 | s | IC MC34050P |
| IC8 | 8-759-205-00 | s | IC TC74HC14F |
| IC9 | 8-759-205-06 | s | IC TC74HC74F |
| IC10 | 8-759-170-05 | s | IC UPC78M05H |
| Q1 | 8-729-900-45 | s | TRANSISTOR DTC114EF |
| Q2 | 8-729-900-45 | s | TRANSISTOR DTC114EF |
| Q3 | 8-729-900-45 | s | TRANSISTOR DTC114EF |
| Q4 | 8-729-378-91 | s | TRANSISTOR 2SD789 |
| Q5 | 8-729-224-02 | s | TRANSISTOR 2SC2240-BL |
| R9 | 1-247-849-00 | s | RES, CARBON 5.6K 5% 1/6W |
| R10 | 1-247-849-00 | s | RES, CARBON 5.6K 5% 1/6W |
| R11 | 1-249-393-11 | s | RES, CARBON 10 5% 1/6W |
| R12 | 1-249-405-11 | s | RES, CARBON 100 5% 1/6W |
| R13 | 1-249-410-11 | s | RES, CARBON 270 5% 1/6W |
| R22 | 1-249-405-11 | s | RES, CARBON 100 5% 1/6W |
| R23 | 1-249-405-11 | s | RES, CARBON 100 5% 1/6W |
| R24 | 1-249-429-11 | s | RES, CARBON 10K 5% 1/6W |
| R37 | 1-249-411-11 | s | RES, CARBON 330 5% 1/6W |
| R38 | 1-249-411-11 | s | RES, CARBON 330 5% 1/6W |
| R39 | 1-249-414-11 | s | RES, CARBON 560 5% 1/6W |

NOTE: Please see pages D-37 and D-38 for the part numbers of capacitors and resistors that are not listed in the parts list.

(SW-157 BOARD, DVR-1000)

| Ref. No. or Qty | Part No. | SP | Description |
|--------------------|--------------|----|--------------------------|
| R40 | 1-249-414-11 | s | RES, CARBON 560 5% 1/6W |
| R45 | 1-249-415-11 | s | RES, CARBON 680 5% 1/6W |
| R46 | 1-249-415-11 | s | RES, CARBON 680 5% 1/6W |
| R47 | 1-249-425-11 | s | RES, CARBON 4.7K 5% 1/6W |
| R48 | 1-249-425-11 | s | RES, CARBON 4.7K 5% 1/6W |
| R49 | 1-249-425-11 | s | RES, CARBON 4.7K 5% 1/6W |
| R50 | 1-249-425-11 | s | RES, CARBON 4.7K 5% 1/6W |
| R51 | 1-249-425-11 | s | RES, CARBON 4.7K 5% 1/6W |
| R52 | 1-249-425-11 | s | RES, CARBON 4.7K 5% 1/6W |
| R53 | 1-249-425-11 | s | RES, CARBON 4.7K 5% 1/6W |
| R54 | 1-249-425-11 | s | RES, CARBON 4.7K 5% 1/6W |
| R55 | 1-249-429-11 | s | RES, CARBON 10K 5% 1/6W |
| R58 | 1-249-414-11 | s | RES, CARBON 560 5% 1/6W |
| R59 | 1-249-417-11 | s | RES, CARBON 1K 5% 1/6W |
| RB1 | 1-235-005-00 | s | RESISTOR BLOCK, 47KX8 |
| RB2 | 1-231-385-00 | s | RESISTOR BLOCK, 4.7KX8 |
| S1 | 1-554-045-21 | s | SWITCH WITH LED, PUSH |
| S2 | 1-554-039-21 | s | SWITCH WITH LED, PUSH |
| S3 | 1-554-040-21 | s | SWITCH, PUSH |
| S4 | 1-554-041-41 | s | SWITCH WITH LED, PUSH |
| S5 | 1-554-041-11 | s | SWITCH WITH LED, PUSH |
| S6 | 1-554-041-11 | s | SWITCH WITH LED, PUSH |
| S7 | 1-554-041-11 | s | SWITCH WITH LED, PUSH |
| S8 | 1-554-041-21 | s | SWITCH WITH LED, PUSH |
| S9 | 1-554-041-31 | s | SWITCH WITH LED, PUSH |
| S10 | 1-554-041-11 | s | SWITCH WITH LED, PUSH |
| S11 | 1-554-041-11 | s | SWITCH WITH LED, PUSH |
| S12 | 1-554-041-11 | s | SWITCH WITH LED, PUSH |
| SP1 | 1-503-299-00 | s | SPEAKER |

SW-178 BOARD, DVR-1000

| Ref. No. or Qty | Part No. | SP | Description |
|--------------------|--------------|----|---------------------------------------|
| 1pc | 1-620-878-11 | o | PC BOARD, SW-158 WITHOUT COMPONENT |
| CN508M | 1-506-478-11 | o | RECEP, 13P, MALE |
| D1 | 8-719-918-88 | s | DIODE 1SS198 |
| D2 | 8-719-918-88 | s | DIODE 1SS198 |
| D3 | 8-719-918-88 | s | DIODE 1SS198 |
| D4 | 8-719-918-88 | s | DIODE 1SS198 |
| D5 | 8-719-918-88 | s | DIODE 1SS198 |
| D6 | 8-719-918-88 | s | DIODE 1SS198 |
| D7 | 8-719-918-88 | s | DIODE 1SS198 |
| D8 | 8-719-918-88 | s | DIODE 1SS198 |
| D9 | 8-719-918-88 | s | DIODE 1SS198 |
| D10 | 8-719-918-88 | s | DIODE 1SS198 |
| D11 | 8-719-918-88 | s | DIODE 1SS198 |
| D12 | 8-719-918-88 | s | DIODE 1SS198 |
| D13 | 8-719-918-88 | s | DIODE 1SS198 |
| D14 | 8-719-918-88 | s | DIODE 1SS198 |
| D15 | 8-719-918-88 | s | DIODE 1SS198 |
| D16 | 8-719-918-88 | s | DIODE 1SS198 |
| D17 | 8-719-918-88 | s | DIODE 1SS198 |
| D18 | 8-719-918-88 | s | DIODE 1SS198 |
| D19 | 8-719-918-88 | s | DIODE 1SS198 |
| D20 | 8-719-918-88 | s | DIODE 1SS198 |
| D21 | 8-719-918-88 | s | DIODE 1SS198 |
| D22 | 8-719-918-88 | s | DIODE 1SS198 |
| D23 | 8-719-918-88 | s | DIODE 1SS198 |
| D24 | 8-719-918-88 | s | DIODE 1SS198 |
| D25 | 8-719-918-88 | s | DIODE 1SS198 |
| D26 | 8-719-918-88 | s | DIODE 1SS198 |
| D27 | 8-719-918-88 | s | DIODE 1SS198 |
| D28 | 8-719-918-88 | s | DIODE 1SS198 |
| D29 | 8-719-918-88 | s | DIODE 1SS198 |
| D30 | 8-719-918-88 | s | DIODE 1SS198 |
| D31 | 8-719-918-88 | s | DIODE 1SS198 |
| D32 | 8-719-918-88 | s | DIODE 1SS198 |
| D33 | 8-719-918-88 | s | DIODE 1SS198 |
| D34 | 8-719-918-88 | s | DIODE 1SS198 |
| D35 | 8-719-918-88 | s | DIODE 1SS198 |
| D36 | 8-719-918-88 | s | DIODE 1SS198 |
| D37 | 8-719-918-88 | s | DIODE 1SS198 |

NOTE: Please see pages D-37 and D-38 for the part numbers of capacitors and resistors that are not listed in the parts list.

SW-179 BOARD, DVR-1000

| Ref. No. or Qty | Part No. | SP | Description |
|--------------------|--------------|----|---------------------------------------|
| 1pc | 1-620-915-11 | o | PC BOARD, SW-179 WITHOUT COMPONENT |
| CN205M | 1-506-481-11 | o | RECEP, 2P, MALE |
| S1 | 1-554-042-41 | s | SWITCH WITH LED, PUSH |

SY-124 BOARD, DVR-1000

| Ref. No. or Qty | Part No. | SP | Description |
|--------------------|--------------|----|--|
| 1pc | A-6017-150-A | o | COMPLETE PCB, SY-124 (This assembly includes the following parts) |
| 1pc | X-3715-349-1 | o | PLATE ASSY, SHIELD, SUB |
| 1pc | 3-722-731-51 | o | LABEL (B), SERIAL NUMBER (SY-124) |
| 2pcs | 3-673-249-11 | o | LEVER, PC BOARD |
| 1pc | 3-715-590-61 | o | LABEL, SERIAL NUMBER |
| 1pc | 3-715-590-71 | o | LABEL, SERIAL NUMBER |
| 2pcs | 7-621-772-58 | s | SCREW +B2x10 |
| 2pcs | 7-622-205-05 | s | NUT 2, TYPE 2 |
| 4pcs | 7-622-207-05 | s | NUT 2.6, TYPE 2 |
| 2pcs | 7-626-320-11 | o | PIN, SPRING 3x8 |
| 4pcs | 7-628-254-30 | s | SCREW +PS 2.6x10 |
| 4pcs | 7-682-647-09 | s | SCREW +PSW3x6 |
| C1 | 1-124-589-11 | s | CAP, ELECT 47 μ F 20% 16V |
| C2 | 1-164-097-11 | s | CAP, CERAMIC 22000PF 50V |
| C3 | 1-164-097-11 | s | CAP, CERAMIC 22000PF 50V |
| C4 | 1-124-589-11 | s | CAP, ELECT 47 μ F 20% 16V |
| C5 | 1-164-097-11 | s | CAP, CERAMIC 22000PF 50V |
| C6 | 1-164-097-11 | s | CAP, CERAMIC 22000PF 50V |
| C7 | 1-164-097-11 | s | CAP, CERAMIC 22000PF 50V |
| C8 | 1-124-589-11 | s | CAP, ELECT 47 μ F 20% 16V |
| C9 | 1-164-097-11 | s | CAP, CERAMIC 22000PF 50V |
| C10 | 1-164-097-11 | s | CAP, CERAMIC 22000PF 50V |
| C11 | 1-164-097-11 | s | CAP, CERAMIC 22000PF 50V |
| C12 | 1-164-097-11 | s | CAP, CERAMIC 22000PF 50V |
| C13 | 1-124-229-00 | s | CAP, ELECT 33 μ F 20% 10V |
| C14 | 1-164-097-11 | s | CAP, CERAMIC 22000PP 50V |
| C15 | 1-164-097-11 | s | CAP, CERAMIC 22000PP 50V |
| C16 | 1-164-097-11 | s | CAP, CERAMIC 22000PP 50V |
| C17 | 1-164-097-11 | s | CAP, CERAMIC 22000PP 50V |
| C18 | 1-164-097-11 | s | CAP, CERAMIC 22000PP 50V |
| C19 | 1-164-097-11 | s | CAP, CERAMIC 22000PP 50V |
| C20 | 1-164-097-11 | s | CAP, CERAMIC 22000PP 50V |
| C21 | 1-164-097-11 | s | CAP, CERAMIC 22000PP 50V |
| C22 | 1-164-097-11 | s | CAP, CERAMIC 22000PP 50V |
| C23 | 1-164-097-11 | s | CAP, CERAMIC 22000PP 50V |
| C24 | 1-164-097-11 | s | CAP, CERAMIC 22000PP 50V |
| C25 | 1-164-097-11 | s | CAP, CERAMIC 22000PP 50V |
| C26 | 1-161-379-00 | s | CAP, CERAMIC 0.01 μ F 20% 25V |
| C27 | 1-164-097-11 | s | CAP, CERAMIC 22000PF 50V |
| C28 | 1-164-097-11 | s | CAP, CERAMIC 22000PF 50V |
| C30 | 1-162-294-31 | s | CAP, CERAMIC 0.001 μ F 10% 50V |
| C31 | 1-126-094-11 | s | CAP, ELECT 4.7 μ F 20% 35V |
| C32 | 1-123-611-00 | s | CAP, ELECT 1 μ F 20% 50V |
| C33 | 1-164-097-11 | s | CAP, CERAMIC 22000PF 50V |
| C35 | 1-164-097-11 | s | CAP, CERAMIC 22000PF 50V |
| C36 | 1-164-097-11 | s | CAP, CERAMIC 22000PF 50V |
| C37 | 1-164-097-11 | s | CAP, CERAMIC 22000PF 50V |
| C39 | 1-164-097-11 | s | CAP, CERAMIC 22000PF 50V |
| C41 | 1-164-097-11 | s | CAP, CERAMIC 22000PF 50V |
| C42 | 1-164-097-11 | s | CAP, CERAMIC 22000PF 50V |
| C49 | 1-164-097-11 | s | CAP, CERAMIC 22000PF 50V |
| C53 | 1-164-097-11 | s | CAP, CERAMIC 22000PF 50V |
| C54 | 1-164-097-11 | s | CAP, CERAMIC 22000PF 50V |
| C61 | 1-164-097-11 | s | CAP, CERAMIC 22000PF 50V |
| C62 | 1-124-229-00 | s | CAP, ELECT 33 μ F 20% 10V |
| C63 | 1-164-097-11 | s | CAP, CERAMIC 22000PF 50V |
| C64 | 1-123-611-00 | s | CAP, ELECT 1 μ F 20% 50V |
| C65 | 1-164-097-11 | s | CAP, CERAMIC 22000PF 50V |
| C66 | 1-124-229-00 | s | CAP, ELECT 33 μ F 20% 10V |
| C67 | 1-164-097-11 | s | CAP, CERAMIC 22000PF 50V |
| C68 | 1-164-097-11 | s | CAP, CERAMIC 22000PF 50V |
| C69 | 1-164-097-11 | s | CAP, CERAMIC 22000PF 50V |
| C70 | 1-164-097-11 | s | CAP, CERAMIC 22000PF 50V |
| C71 | 1-164-097-11 | s | CAP, CERAMIC 22000PF 50V |
| C72 | 1-164-097-11 | s | CAP, CERAMIC 22000PF 50V |
| C73 | 1-164-097-11 | s | CAP, CERAMIC 22000PF 50V |
| CN1F | 1-563-339-11 | o | RECEP, 48P, FEMALE |
| CN413M | 1-506-748-11 | s | RECEP, DIN 96P, MALE |
| CN414M | 1-506-746-11 | s | RECEP, DIN 48P, MALE |
| D1 | 8-719-400-35 | s | LED LN35BP (GREEN) |
| D2 | 8-719-800-60 | s | LED TLR214 (RED) |

NOTE: Please see pages D-37 and D-38 for the part numbers of capacitors and resistors that are not listed in the parts list.

(SY-124 BOARD, DVR-1000)

| Ref. No. or Qty | Part No. | SP | Description |
|--------------------|--------------|----|--------------------------|
| ICA4 | 8-752-800-46 | s | IC CXQ70108P-8 |
| ICA6 | 8-759-203-48 | s | IC TC74HC573P |
| ICA8 | 8-759-113-74 | s | IC UPD7200IC |
| ICA9 | 8-759-737-95 | s | IC MBM27C512-SY1240132 |
| ICA10 | 8-749-901-66 | s | ICDS1235Y |
| ICA12 | 8-759-105-76 | s | IC UPD71059C |
| ICA13 | 8-759-105-77 | s | IC UPD71054C |
| ICA14 | 8-759-917-05 | s | IC SN74HC541N |
| ICA15 | 8-759-203-50 | s | IC TC74HC574P |
| ICA16 | 8-759-795-28 | s | IC PAL16L8B-SY124022 |
| ICA17 | 8-759-300-55 | s | IC HM6148HP-55 |
| ICA18 | 8-759-916-29 | s | IC SN74HC74N |
| ICA19 | 8-759-921-34 | s | IC SN74HC245N |
| ICA20 | 8-759-203-50 | s | IC TC74HC574P |
| ICA21 | 8-759-939-90 | s | IC CD74HC40105E |
| ICB1 | 8-759-803-70 | s | IC LC74HC08 |
| ICB6 | 8-759-107-59 | s | IC CXQ71086P |
| ICB13 | 8-759-038-14 | s | IC MC74HC4538AN |
| ICB14 | 8-759-202-21 | s | IC TC74HC32P |
| ICB15 | 8-759-202-26 | s | IC TC74HC138P |
| ICB16 | 8-759-202-55 | s | IC TC74HC244P |
| ICB17 | 8-759-909-16 | s | IC CX7907A |
| ICB20 | 8-759-909-72 | s | IC CX7912A |
| ICC1 | 8-759-202-21 | s | IC TC74HC32P |
| ICC2 | 8-759-203-33 | s | IC TC74HC367P |
| ICC3 | 8-759-107-56 | s | IC CXQ71011P |
| ICC4 | 8-759-202-21 | s | IC TC74HC32P |
| ICC5 | 8-759-202-21 | s | IC TC74HC32P |
| ICC7 | 8-759-202-26 | s | IC TC74HC138P |
| ICC8 | 8-759-112-36 | S | IC UPD3341C |
| ICC9 | 8-759-112-36 | s | IC UPD3341C |
| ICC10 | 8-759-917-05 | s | IC SN74HC541N |
| ICC11 | 8-759-202-74 | s | IC TC74HC04P |
| ICC13 | 8-759-004-64 | s | IC MC74HC126N |
| ICC14 | 8-759-004-63 | s | IC MC74HC125N |
| ICC15 | 8-759-202-21 | s | IC TC74HC32P |
| ICC16 | 8-759-040-46 | s | IC MC14046BCP |
| ICD1 | 8-759-916-29 | s | IC SN74HC74N |
| ICD2 | 8-759-916-35 | s | IC SN74HC107N |
| ICD3 | 8-759-202-74 | s | IC TC74HC04P |
| ICD4 | 8-759-203-33 | s | IC TC74HC367P |
| ICD5 | 8-759-011-90 | s | IC MC34050P |
| ICD6 | 8-759-107-59 | s | IC CXQ71086P |
| ICD7 | 8-759-916-29 | s | IC SN74HC74N |
| ICD8 | 8-759-112-36 | s | IC UPD3341C |
| ICD9 | 8-759-917-05 | s | IC SN74HC541N |
| ICD10 | 8-759-112-36 | s | IC UPD3341C |
| ICD13 | 8-759-916-20 | s | IC SN74HC14N |
| ICD14 | 8-759-202-11 | s | IC TC74HC00P |
| ICD15 | 8-759-202-11 | s | IC TC74HC00P |
| ICD16 | 8-759-202-74 | s | IC TC74HC04P |
| ICD17 | 8-759-202-74 | s | IC TC74HC04P |
| ICD18 | 8-759-921-08 | s | IC SN74HC02N |
| ICD19 | 8-759-202-21 | s | IC TC74HC32P |
| ICD21 | 8-759-916-35 | s | IC SN74HC107N |
| ICD22 | 8-759-202-24 | s | IC TC74HC86P |
| L1 | 1-421-329-00 | s | COIL, CHOKE |
| L2 | 1-421-329-00 | s | COIL, CHOKE |
| L3 | 1-421-329-00 | s | COIL, CHOKE |
| R4 | 1-249-411-11 | s | RES, CARBON 330 5% 1/4W |
| R5 | 1-249-409-11 | s | RES, CARBON 220 5% 1/4W |
| R6 | 1-249-409-11 | s | RES, CARBON 220 5% 1/4W |
| R7 | 1-249-429-11 | s | RES, CARBON 10K 5% 1/4W |
| R8 | 1-247-895-00 | s | RES, CARBON 470K 5% 1/4W |
| R9 | 1-249-441-11 | s | RES, CARBON 100K 5% 1/4W |
| R10 | 1-249-435-11 | s | RES, CARBON 33K 5% 1/4W |
| R12 | 1-249-429-11 | s | RES, CARBON 10K 5% 1/4W |
| R13 | 1-249-429-11 | s | RES, CARBON 10K 5% 1/4W |
| R15 | 1-249-429-11 | s | RES, CARBON 10K 5% 1/4W |

(SY-124 BOARD, DVR-1000)

| Ref. No. or Qty | Part No. | SP | Description |
|--------------------|--------------|----|---------------------------------|
| R16 | 1-249-429-11 | s | RES, CARBON 10K 5% 1/4W |
| R17 | 1-249-429-11 | s | RES, CARBON 10K 5% 1/4W |
| R18 | 1-249-429-11 | s | RES, CARBON 10K 5% 1/4W |
| R19 | 1-249-417-11 | s | RES, CARBON 1K 5% 1/4W |
| R20 | 1-247-862-11 | s | RES, CARBON 20K 5% 1/4W |
| R21 | 1-249-417-11 | s | RES, CARBON 1K 5% 1/4W |
| R22 | 1-249-429-11 | s | RES, CARBON 10K 5% 1/4W |
| R23 | 1-249-429-11 | s | RES, CARBON 10K 5% 1/4W |
| R24 | 1-249-405-11 | s | RES, CARBON 100 5% 1/4W |
| R25 | 1-249-429-11 | s | RES, CARBON 10K 5% 1/4W |
| RB1 | 1-231-410-00 | s | RESISTOR BLOCK 10Kx8 |
| RB2 | 1-231-410-00 | s | RESISTOR BLOCK 10Kx8 |
| RB3 | 1-231-410-00 | s | RESISTOR BLOCK 10Kx8 |
| RB4 | 1-231-410-00 | s | RESISTOR BLOCK 10Kx8 |
| RB5 | 1-231-410-00 | s | RESISTOR BLOCK 10Kx8 |
| RB6 | 1-231-410-00 | s | RESISTOR BLOCK 10Kx8 |
| RB7 | 1-231-533-00 | s | RESISTOR BLOCK 10Kx4 |
| RB8 | 1-231-410-00 | s | RESISTOR BLOCK 10Kx8 |
| RB11 | 1-231-533-00 | s | RESISTOR BLOCK 10Kx4 |
| S1 | 1-553-856-00 | s | SWITCH with LED, PUSH |
| X1 | 1-567-794-11 | s | OSCILLATOR, CRYSTAL 14, 31818MH |
| X2 | 1-567-795-11 | s | OSCILLATOR, CRYSTAL 14.5MHZ |

NOTE: Please see pages D-37 and D-38 for the part numbers of capacitors and resistors that are not listed in the parts list.

TR-40 BOARD, DVR-1000

| Ref. No. or Qty | Part No. | SP | Description |
|--------------------|--------------|----|--|
| 1pc | A-6025-113-A | o | COMPLETE PCB, TR-40 (This assembly includes the following parts.) |
| 1pc | 7-682-647-09 | s | SCREW +PWH 3X6 |
| C1 | 1-162-284-31 | s | CAP, CERAMIC 150PF 10% 50V |
| C4 | 1-162-284-31 | s | CAP, CERAMIC 150PF 10% 50V |
| C7 | 1-162-294-31 | s | CAP, CERAMIC 0.001uF 10% 50V |
| C8 | 1-162-294-31 | s | CAP, CERAMIC 0.001uF 10% 50V |
| C9 | 1-131-365-00 | s | CAP, TANT 10uF 20% 20V |
| C10 | 1-131-365-00 | s | CAP, TANT 10uF 20% 20V |
| C19 | 1-130-475-00 | s | CAP, MYLAR 0.0022uF 5% 50V |
| C35 | 1-124-584-00 | s | CAP, ELECT 100uF 20% 10V |
| C36 | 1-124-584-00 | s | CAP, ELECT 100uF 20% 10V |
| C37 | 1-131-348-00 | s | CAP, TANT 1.5uF 10% 35V |
| C38 | 1-131-348-00 | s | CAP, TANT 1.5uF 10% 35V |
| C39 | 1-162-282-31 | s | CAP, CERAMIC 100PF 10% 50V |
| C40 | 1-162-282-31 | s | CAP, CERAMIC 100PF 10% 50V |
| C41 | 1-162-282-31 | s | CAP, CERAMIC 100PF 10% 50V |
| C42 | 1-162-282-31 | s | CAP, CERAMIC 100PF 10% 50V |
| CN901M | 1-506-473-11 | o | RECEP, 8P, MALE |
| CN902M | 1-506-475-11 | o | RECEP, 10P, MALE |
| CN903M | 1-506-471-11 | o | RECEP, 6P, MALE |
| CN904M | 1-506-458-11 | o | RECEP, 3P, MALE |
| CN905M | 1-506-475-21 | o | RECEP, 10P, MALE |
| CN906M | 1-506-483-21 | o | RECEP, 4P, MALE |
| CN907M | 1-506-618-11 | o | RECEP, PS 6P, MALE |
| CN908M | 1-506-486-11 | o | RECEP, 7P, MALE |
| D1 | 8-719-815-55 | s | DIODE 1S1555 |
| D2 | 8-719-815-55 | s | DIODE 1S1555 |
| IC1 | 8-759-100-06 | s | IC uPC4556C |
| IC2 | 8-759-603-82 | s | IC M5241L |
| IC3 | 8-759-240-53 | s | IC TC4053BP |
| IC4 | 8-759-100-06 | s | IC uPC4556C |
| IC5 | 8-759-145-58 | s | IC uPC4558C |
| IC6 | 8-759-145-58 | s | IC uPC4558C |
| IC7 | 8-759-145-58 | s | IC uPC4558C |
| IC8 | 8-759-145-58 | s | IC uPC4558C |
| IC9 | 8-759-240-52 | s | IC TC4052BP |
| IC10 | 8-759-925-26 | s | IC CX23026 |
| IC11 | 8-759-602-83 | s | IC M5238P |
| L1 | 1-421-370-00 | s | COIL, CHOKE |
| L2 | 1-421-370-00 | s | COIL, CHOKE |
| L3 | 1-421-370-00 | s | COIL, CHOKE |
| L4 | 1-421-370-00 | s | COIL, CHOKE |
| Q1 | 1-807-103-11 | s | TRANSISTOR DTC114YS |
| Q2 | 8-729-900-36 | s | TRANSISTOR DTC124ES |
| Q3 | 8-729-900-36 | s | TRANSISTOR DTC124ES |
| Q4 | 8-729-606-32 | s | TRANSISTOR 2SC2603-E |
| Q5 | 8-729-900-36 | s | TRANSISTOR DTC124ES |
| Q6 | 8-729-900-36 | s | TRANSISTOR DTC124ES |
| Q7 | 8-729-201-05 | s | TRANSISTOR 2SC2878-B |
| Q8 | 8-729-201-05 | s | TRANSISTOR 2SC2878-B |
| Q9 | 8-729-201-05 | s | TRANSISTOR 2SC2878-B |
| Q10 | 8-729-201-05 | s | TRANSISTOR 2SC2878-B |
| Q11 | 8-729-900-36 | s | TRANSISTOR DTC124ES |
| Q12 | 8-729-900-63 | s | TRANSISTOR DTA124ES |
| R1 | 1-247-826-00 | s | RES, CARBON 620 5% 1/4W |
| R2 | 1-247-826-00 | s | RES, CARBON 620 5% 1/4W |
| R3 | 1-247-826-00 | s | RES, CARBON 620 5% 1/4W |
| R4 | 1-249-425-11 | s | RES, CARBON 4.7K 5% 1/6W |
| R5 | 1-249-429-11 | s | RES, CARBON 10K 5% 1/6W |
| R6 | 1-214-865-00 | s | RES, METAL 1.1K 1% 1/2W |
| R7 | 1-247-826-00 | s | RES, CARBON 620 5% 1/4W |
| R8 | 1-247-826-00 | s | RES, CARBON 620 5% 1/4W |
| R9 | 1-247-826-00 | s | RES, CARBON 620 5% 1/4W |
| R16 | 1-216-450-00 | s | RES, METAL 82 5% 2W |
| R17 | 1-216-450-00 | s | RES, METAL 82 5% 2W |
| R23 | 1-249-437-11 | s | RES, CARBON 47K 5% 1/6W |
| R24 | 1-249-405-11 | s | RES, CARBON 100 5% 1/6W |
| R33 | 1-249-405-11 | s | RES, CARBON 100 5% 1/6W |
| R34 | 1-249-405-11 | s | RES, CARBON 100 5% 1/6W |
| R35 | 1-249-405-11 | s | RES, CARBON 100 5% 1/6W |
| R36 | 1-249-405-11 | s | RES, CARBON 100 5% 1/6W |
| R37 | 1-249-421-11 | s | RES, CARBON 2.2K 5% 1/6W |
| R38 | 1-249-435-11 | s | RES, CARBON 33K 5% 1/6W |
| R39 | 1-249-435-11 | s | RES, CARBON 33K 5% 1/6W |
| R40 | 1-249-436-11 | s | RES, CARBON 39K 5% 1/6W |

(TR-40 BOARD DVR-1000)

| Ref. No. or Qty | Part No. | SP | Description |
|--------------------|--------------|----|-----------------------------|
| R41 | 1-249-429-11 | s | RES, CARBON 10K 5% 1/6W |
| R43 | 1-249-429-11 | s | RES, CARBON 10K 5% 1/6W |
| R44 | 1-249-417-11 | s | RES, CARBON 1K 5% 1/6W |
| R45 | 1-249-433-11 | s | RES, CARBON 22K 5% 1/6W |
| R46 | 1-249-421-11 | s | RES, CARBON 2.2K 5% 1/6W |
| R47 | 1-249-429-11 | s | RES, CARBON 10K 5% 1/6W |
| R52 | 1-249-429-11 | s | RES, CARBON 10K 5% 1/6W |
| R53 | 1-249-429-11 | s | RES, CARBON 10K 5% 1/6W |
| R54 | 1-249-437-11 | s | RES, CARBON 47K 5% 1/6W |
| R56 | 1-249-429-11 | s | RES, CARBON 10K 5% 1/6W |
| R57 | 1-249-429-11 | s | RES, CARBON 10K 5% 1/6W |
| R58 | 1-214-868-00 | s | RES, METAL 1.5K 1% 1/2W |
| R59 | 1-249-421-11 | s | RES, CARBON 2.2K 5% 1/6W |
| R60 | 1-249-433-11 | s | RES, CARBON 22K 5% 1/6W |
| R61 | 1-249-429-11 | s | RES, CARBON 10K 5% 1/4W |
| RB1 | 1-231-549-11 | s | RESISTOR BLOCK, 47KX4 |
| RY1 | 1-515-683-11 | s | RELAY |
| T1 | 1-423-189-00 | s | TRANSFORMER, INPUT |
| T2 | 1-423-189-00 | s | TRANSFORMER, INPUT |
| TH1 | 1-807-749-11 | s | THERMISTOR, POSITIVE 68-OHM |
| TH2 | 1-807-749-11 | s | THERMISTOR, POSITIVE 68-OHM |

NOTE: Please see pages D-37 and D-38 for the part numbers of capacitors and resistors that are not listed in the parts list.

TR-41 BOARD, DVR-1000

Ref. No. or Qty Part No. SP Description

The following components are included in the CD BLOCK assy; A-6029-012-A.

| | | | |
|----|--------------|---|------------------|
| Q1 | 8-729-116-45 | s | TRANSISTOR PH110 |
| Q2 | 8-729-116-45 | s | TRANSISTOR PH110 |
| Q3 | 8-729-116-45 | s | TRANSISTOR PH110 |
| Q4 | 8-729-116-45 | s | TRANSISTOR PH110 |
| Q5 | 8-729-116-45 | s | TRANSISTOR PH110 |

VR-50 BOARD, DVR-1000

Ref. No. or Qty Part No. SP Description

| | | | |
|--------|--------------|---|--------------------------------------|
| 1pc | 1-620-907-11 | o | PC BOARD, VR-50 WITHOUT COMPONENT |
| CN201M | 1-506-471-11 | o | RECEP, 6P, MALE |
| CN202M | 1-506-471-11 | o | RECEP, 6P, MALE |
| J1 | 1-507-552-21 | s | JACK, PHONE |
| R1 | 1-237-579-11 | s | RES, VAR, CARBON 10/10K |
| R2 | 1-228-549-00 | s | RES WITH SW, VAR, CARBON, 10K(B) |

NOTE: Please see pages D-37 and D-38 for the part numbers of capacitors and resistors that are not listed in the parts list.

FRAME, DVR-1000

| Ref. No. or Qty | Part No. | SP | Description |
|---|------------------------------|----|--|
| 1pc | 1-559-046-11 | s | WIRE, FLEXIBLE CARD 4P |
| 1pc | 1-559-107-11 | s | CODE, CONNECTION (1m) |
| 1pc | 1-938-374-12 | s | HARNESS, RF(A) Includes the CN743F. |
| 1pc | 1-938-375-12 | s | HARNESS, RF(B) Includes the CN742F. |
| 1pc | 1-938-494-11 | s | FLAT CABLE ASSY, IFN-1 50P/50P Includes the following connectors. CN727F (to MB-133 board) CN801F (to IF-138 board) |
| 2pcs | 1-559-045-11 | s | WIRE, FLEXIBLE CARD 26P |
| CB1 | 1-532-545-51 | s | BREAKER, CIRCUIT |
| CN101 | 1-526-956-11 | s | INLET, WITH NOISE FILTER, 3P |
| CN102F | 1-561-070-00 1-561-067-00 | o | HOUSING, 4P CONTACT, FEMALE AWG14-20 |
| CN102M | 1-561-084-00 1-561-068-00 | o | HOUSING, 4P CONTACT, MALE ARG14-20 |
| CN103F (to PS-138 board) | 1-560-072-00 1-561-067-00 | o | HOUSING, 9P CONTACT, FEMALE AWG14-20 |
| CN104F (to PS-138 board) | 1-509-984-00 1-560-298-00 | o | HOUSING, IL, 3P CONTACT, FEMALE AWG22-28 |
| CN105F (to PS-138 board) Refer to MB-137 board | | | |
| CN106F (to PS-138 board) | 1-563-116-11 1-563-115-11 | o | HOUSING, PS 4P CONTACT, FEMALE AWG24-28 |
| CN107F (to PS-138 board) | 1-563-119-11 1-563-115-11 | o | HOUSING, PS 10P CONTACT, FEMALE AWG24-28 |
| CN108F (to PS-138 board) | 1-563-120-11 1-563-115-11 | o | HOUSING, PS 12P CONTACT, FEMALE AWG24-28 |
| CN109F (to PS-138 board) | 1-509-984-00 1-560-298-00 | o | HOUSING, IL 3P CONTACT, FEMALE AWG22-28 |
| CN124F (to PS-138 board) | 1-561-073-00 1-535-206-00 | o | HOUSING, 15P CONTACT, FEMALE AWG18-24 |
| CN133F (to MB-137 board) Refer to MB-137 board | | | |
| CN134F (to MB-137 board) Refer to MB-137 board | | | |
| CN135F (to MB-137 board) Refer to MB-137 board | | | |
| CN201F (to FC-37 board) | 1-562-151-11 1-563-088-11 | o | HOUSING, 6P CONTACT, FEMALE AWG24-30 |
| CN202F (to VR-50 board) | 1-562-151-11 1-563-088-11 | o | HOUSING, 6P CONTACT, FEMALE AWG24-30 |
| CN203F (to LE-56 board) | 1-562-153-11 1-563-088-11 | o | HOUSING, 8P CONTACT, FEMALE AWG24-30 |
| CN204F (to FP-24 board) | 1-563-118-11 1-563-115-11 | o | HOUSING, PS 8P CONTACT, FEMALE AWG24-28 |

(FRAME, DVR-1000)

| Ref. No. or Qty | Part No. | SP | Description |
|--|------------------------------|----|---|
| CN205F (to SW-179 board) | 1-562-147-11 1-563-088-11 | o | HOUSING, 2P CONTACT, FEMALE AWG24-30 |
| CN206F (to PE-18 board) | 1-562-147-11 1-563-088-11 | o | HOUSING, 2P CONTACT, FEMALE AWG24-30 |
| CN210F (to FC-37 board) | 1-563-122-11 1-563-115-11 | o | HOUSING, PS 16P CONTACT, FEMALE AWG24-28 |
| CN211F (to FC-37 board) Refer to MB-137 board | | | |
| CN212F (to FC-37 board) | 1-563-122-11 1-563-115-11 | o | HOUSING, PS 16P CONTACT, FEMALE AWG24-28 |
| CN213F (to FC-37 board) Refer to MB-137 board | | | |
| CN214F (to FC-37 board) | 1-563-121-11 1-563-115-11 | o | HOUSING, PS 14P CONTACT, FEMALE AWG24-28 |
| CN215F (to FC-37 board) Refer to MB-137 board | | | |
| CN216F (to FC-37 board) | 1-562-148-11 1-563-115-11 | o | HOUSING, 3P CONTACT, FEMALE AWG24-28 |
| CN217F (to FC-37 board) Refer to MB-137 board | | | |
| CN218F (to FC-37 board) | 1-563-116-11 1-563-115-11 | o | HOUSING, PS 4P CONTACT, FEMALE AWG24-28 |
| CN219F (to FC-37 board) | 1-563-117-11 1-563-115-11 | o | HOUSING, PS 6P CONTACT, FEMALE AWG24-28 |
| CN220F (to FC-37 board) | 1-563-116-11 1-563-115-11 | o | HOUSING, PS 4P CONTACT, FEMALE AWG24-28 |
| CN221F (to FC-37 board) Refer to MB-137 board | | | |
| CN222F (to FC-37 board) | 1-563-121-11 1-563-115-11 | o | HOUSING, PS 14P CONTACT, FEMALE AWG24-28 |
| CN223F (to FC-37 board) Refer to MB-137 board | | | |
| CN301F (to SE-47 board) | 1-562-149-11 1-563-088-11 | o | HOUSING, 4P CONTACT, FEMALE AWG24-30 |
| CN302F (to SE-47 board) | 1-562-155-11 1-563-088-11 | o | HOUSING, 10P CONTACT, FEMALE AWG24-30 |
| CN303F (to SE-47 board) | 1-562-153-11 1-563-088-11 | o | HOUSING, 8P CONTACT, FEMALE AWG24-30 |
| CN304F (to SE-47 board) | 1-562-151-11 1-563-088-11 | o | HOUSING, 6P CONTACT, FEMALE AWG24-30 |
| CN305F (to SE-47 board) | 1-562-151-11 1-563-088-11 | o | HOUSING, 6P CONTACT, FEMALE AWG24-30 |
| CN306F (to SE-47 board) | 1-562-151-11 1-563-088-11 | o | HOUSING, 6P CONTACT, FEMALE AWG24-30 |

(FRAME, DVR-1000)

| Ref. No. or Qty | Part No. | SP | Description |
|---------------------------|--------------|----|----------------------------|
| CN307F (to SE-47 board) | | | |
| | 1-562-151-11 | o | HOUSING, 6P |
| | 1-563-088-11 | o | CONTACT, FEMALE AWG24-30 |
| CN308F (to SE-47 board) | | | |
| | 1-562-153-11 | o | HOUSING, 8P |
| | 1-563-088-11 | o | CONTACT, FEMALE AWG24-30 |
| CN310F (to CS-21 board) | | | |
| | 1-562-153-11 | o | HOUSING, 8P |
| | 1-563-088-11 | o | CONTACT, FEMALE AWG24-30 |
| CN406F (to CN-157 board) | | | |
| | 1-563-122-11 | o | HOUSING, PS 16P |
| | 1-563-115-11 | o | CONTACT, FEMALE AWG24-28 |
| CN407F (to CN-157 board) | | | |
| | 1-562-150-11 | o | HOUSING, 5P |
| | 1-563-088-11 | o | CONTACT, FEMALE AWG24-30 |
| CN410F (to CN-157 board) | | | |
| | 1-563-122-11 | o | HOUSING, PS 16P |
| | 1-563-115-11 | o | CONTACT, FEMALE AWG24-28 |
| CN411F (to CN-157 board) | | | |
| | 1-562-150-11 | o | HOUSING, 5P |
| | 1-563-088-11 | o | CONTACT, FEMALE AWG24-30 |
| CN412F (to CAPSTAN MOTOR) | | | |
| | 1-562-153-11 | o | HOUSING, 8P |
| | 1-563-088-11 | o | CONTACT, FEMALE AWG24-30 |
| CN414F (to BP-10 board) | | | |
| | 1-563-116-11 | o | HOUSING, PS 4P |
| | 1-563-115-11 | o | CONNECTOR, FEMALE AWG24-28 |
| CN415F (to BP-10 board) | | | |
| | 1-563-116-11 | o | HOUSING, PS 4P |
| | 1-563-115-11 | o | CONTACT, FEMALE AWG24-28 |
| CN416F (to BP-10 board) | | | |
| | 1-562-152-11 | o | HOUSING, 7P |
| | 1-563-088-11 | o | CONTACT, FEMALE AWG24-30 |
| CN417F (to BP-10 board) | | | |
| | 1-562-149-11 | o | HOUSING, 4P |
| | 1-563-088-11 | o | CONTACT, FEMALE AWG24-30 |
| CN418F (to BP-10 board) | | | |
| | 1-562-148-11 | o | HOUSING, 3P |
| | 1-563-088-11 | o | CONTACT, FEMALE AWG24-30 |
| CN421F (to DRUM) | | | |
| | 1-561-518-11 | o | HOUSING, IL 6P |
| | 1-506-740-11 | o | CONTACT, FEMALE AWG22-28 |
| CN422F (to DRUM MOTOR) | | | |
| | 1-561-519-11 | o | HOUSING, IL 8P |
| | 1-506-740-11 | o | CONTACT, FEMALE AWG22-28 |
| CN423F (to DRUM MOTOR) | | | |
| | 1-561-518-11 | o | HOUSING, IL 6P |
| | 1-506-740-11 | o | CONTACT, FEMALE AWG22-28 |
| CN424F (to HEAD DRUM) | | | |
| | 1-562-148-11 | o | HOUSING, 3P |
| | 1-563-088-11 | o | CONTACT, FEMALE AWG24-30 |
| CN430F (to AH-13 board) | | | |
| | 1-562-147-11 | o | HOUSING, 2P |
| | 1-563-088-11 | o | CONTACT, FEMALE AWG24-30 |
| CN432F (to AH-13 board) | | | |
| | 1-562-147-11 | o | HOUSING, 2P |
| | 1-563-088-11 | o | CONTACT, FEMALE AWG24-30 |
| CN433F (to AH-13 board) | | | |
| | 1-562-151-11 | o | HOUSING, 6P |
| | 1-563-088-11 | o | CONTACT, FEMALE AWG24-30 |

(FRAME, DVR-1000)

| Ref. No. or Qty | Part No. | SP | Description |
|--------------------------|--------------|----|----------------------------|
| CN434F (to AH-15 board) | | | |
| | 1-562-147-11 | o | HOUSING, 2P |
| | 1-563-088-11 | o | CONTACT, FEMALE AWG24-30 |
| CN701F (to MB-133 board) | | | |
| | 1-563-122-11 | o | HOUSING, PS 16P |
| | 1-563-115-11 | o | CONTACT, FEMALE AWG24-28 |
| CN703F (to MB-133 board) | | | |
| | 1-562-153-11 | o | HOUSING, 8P |
| | 1-563-088-11 | o | CONTACT, FEMALE AWG24-30 |
| CN704F (to FP-24 board) | | | |
| | 1-563-127-11 | o | HOUSING, PS 26P |
| | 1-563-115-11 | o | CONTACT, FEMALE AWG24-28 |
| CN707F (to MB-133 board) | | | |
| | 1-563-117-11 | o | HOUSING, PS 6P |
| | 1-563-115-11 | o | CONTACT, FEMALE AWG24-28 |
| CN708F (to MB-133 board) | | | |
| | 1-562-155-11 | o | HOUSING, 10P |
| | 1-563-088-11 | o | CONTACT, FEMALE AWG24-30 |
| CN709F (to MB-133 board) | | | |
| | 1-562-150-11 | o | HOUSING, 5P |
| | 1-563-088-11 | o | CONTACT, FEMALE AWG24-30 |
| CN710F (to MB-133 board) | | | |
| | 1-562-148-11 | o | HOUSING, 3P |
| | 1-563-088-11 | o | CONTACT, FEMALE AWG24-30 |
| CN711F (to MB-133 board) | | | |
| | 1-563-120-11 | o | HOUSING, PS 12P |
| | 1-563-115-11 | o | CONTACT, FEMALE AWG24-28 |
| CN712F (to MB-133 board) | | | |
| | 1-563-121-11 | o | HOUSING, PS 14P |
| | 1-563-115-11 | o | CONTACT, FEMALE AWG24-28 |
| CN716F (to MB-133 board) | | | |
| | 1-563-120-11 | o | HOUSING, PS 12P |
| | 1-563-115-11 | o | CONNECTOR, FEMALE AWG24-28 |
| CN717F (to MB-133 board) | | | |
| | 1-562-151-11 | o | HOUSING, 6P |
| | 1-563-088-11 | o | CONTACT, FEMALE AWG24-30 |
| CN726F (to MB-133 board) | | | |
| | 1-562-151-11 | o | HOUSING, 6P |
| | 1-563-088-11 | o | CONTACT, FEMALE AWG24-30 |
| CN728F (to MB-133 board) | | | |
| | 1-561-863-00 | o | HOUSING, 5P |
| | 1-535-206-00 | s | CONTACT, FEMALE AWG18-24 |
| CN729F (to MB-133 board) | | | |
| | 1-562-958-11 | o | HOUSING, 15P |
| | 1-563-088-11 | o | CONTACT, FEMALE AWG24-30 |
| CN730F (to MB-133 board) | | | |
| | 1-563-117-11 | o | HOUSING, PS 6P |
| | 1-563-115-11 | o | CONTACT, FEMALE AWG24-28 |
| CN731F (to MB-133 board) | | | |
| | 1-562-152-11 | o | HOUSING, 7P |
| | 1-563-088-11 | o | CONTACT, FEMALE AWG24-30 |
| CN732F (to MB-133 board) | | | |
| | 1-563-116-11 | o | HOUSING, PS 4P |
| | 1-563-115-11 | o | CONTACT, FEMALE AWG24-28 |
| CN740F (to RF-15 board) | | | |
| | 1-562-958-11 | o | HOUSING, 15P |
| | 1-563-088-11 | o | CONTACT, FEMALE AWG24-30 |
| CN741F (to RF-15 board) | | | |
| | 1-562-157-11 | o | HOUSING, 12P |
| | 1-563-088-11 | o | CONTACT, FEMALE AWG24-30 |

(FRAME, DVR-1000)

| Ref. No. or Qty | Part No. | SP | Description |
|--------------------------|--------------|----|---|
| CN743F (to RF-15 board) | 1-562-157-11 | o | HOUSING, 12P |
| | 1-563-088-11 | o | CONTACT, FEMALE AWG24-30 Included in the HARNESS, RF(A). |
| CN744F (to RF-15 board) | 1-562-148-11 | o | HOUSING, 3P |
| | 1-563-088-11 | o | CONTACT, FEMALE AWG24-30 |
| CN901F (to TR-40 board) | 1-562-153-11 | o | HOUSING, 8P |
| | 1-563-088-11 | o | CONTACT, FEMALE AWG24-30 |
| CN902F (to TR-40 board) | 1-562-155-11 | o | HOUSING, 10P |
| | 1-563-088-11 | o | CONTACT, FEMALE AWG24-30 |
| CN903F (to TR-40 board) | 1-562-151-11 | o | HOUSING, 6P |
| | 1-563-088-11 | o | CONTACT, FEMALE AWG24-30 |
| CN904F (to TR-40 board) | 1-562-148-11 | o | HOUSING, 3P |
| | 1-563-088-11 | o | CONTACT, FEMALE AWG24-30 |
| CN905F (to TR-40 board) | 1-562-155-11 | o | HOUSING, 10P |
| | 1-563-088-11 | o | CONTACT, FEMALE AWG24-30 |
| CN906F (to TR-40 board) | 1-562-149-11 | o | HOUSING, 4P |
| | 1-563-088-11 | o | CONTACT, FEMALE AWG24-30 |
| CN907F (to TR-40 board) | 1-563-117-11 | o | HOUSING, PS 6P |
| | 1-563-115-11 | o | CONTACT, FEMALE AWG24-28 |
| CN908F (to TR-40 board) | 1-562-152-11 | o | HOUSING, 7P |
| | 1-563-088-11 | o | CONTACT, FEMALE AWG24-30 |
| CN910F (to LO-015 board) | 1-562-151-11 | o | HOUSING, 6P |
| | 1-563-088-11 | o | CONTACT, FEMALE AWG24-30 |
| CN911F (to LO-05 board) | 1-562-151-11 | o | HOUSING, 6P |
| | 1-563-088-11 | o | CONTACT, FEMALE AWG24-30 |
| CN912F (to LO-05 board) | 1-563-117-11 | o | HOUSING, PS 6P |
| | 1-563-115-11 | o | CONTACT, FEMALE AWG24-28 |
| CN913F (to LO-05 board) | 1-562-148-11 | o | HOUSING, 3P |
| | 1-563-088-11 | o | CONTACT, FEMALE AWG24-30 |
| CN914F (to LO-05 board) | 1-562-150-11 | o | HOUSING, 5P |
| | 1-563-088-11 | o | CONTACT, FEMALE AWG24-30 |
| CN915F (to LO-05 board) | 1-562-148-11 | o | HOUSING, 3P |
| | 1-563-088-11 | o | CONTACT, FEMALE AWG24-30 |
| CN916F (to LO-05 board) | 1-509-984-00 | o | HOUSING, IL 3P |
| | 1-560-298-00 | o | CONTACT, FEMALE AWG22-28 |
| CN920F (to PR-87 board) | 1-562-157-11 | o | HOUSING, 12P |
| | 1-563-088-11 | o | CONTACT, FEMALE AWG24-30 |
| CN921F (to PR-87 board) | 1-562-958-11 | o | HOUSING, 15P |
| | 1-563-088-11 | o | CONTACT, FEMALE AWG24-30 |
| CN922F (to PR-87 board) | 1-562-958-11 | o | HOUSING, 15P |
| | 1-563-088-11 | o | CONTACT, FEMALE AWG24-30 |

(FRAME, DVR-1000)

| Ref. No. or Qty | Part No. | SP | Description |
|--------------------------|--------------|----|---|
| CN923F (to PR-87 board) | 1-562-151-11 | o | HOUSING, 6P |
| | 1-563-088-11 | o | CONTACT, FEMALE AWG24-30 |
| CN930F (to PD-36 board) | | | Refer to MB-137 board |
| CN931F (to PD-36 board) | 1-562-148-11 | o | HOUSING, 3P |
| | 1-563-088-11 | o | CONTACT, FEMALE AWG24-30 |
| CN940 (CUE OUT) | 1-509-176-51 | s | RECEP, XLR 3P, MALE (for UC,EK) |
| | 1-509-184-51 | s | RECEP, XLR 3P, FEMALE (for J) |
| CN941 (TIME CODE OUT) | 1-509-176-51 | s | RECEP, XLR 3P, MALE (for UC,EK) |
| | 1-509-184-51 | s | RECEP, XLR 3P, FEMALE (for J) |
| CN942 (MONITOR OUT R) | 1-509-176-51 | s | RECEP, XLR 3P, MALE (for UC,EK) |
| | 1-509-184-51 | s | RECEP, XLR 3P, FEMALE (for J) |
| CN943 (MONITOR OUT L) | 1-509-176-51 | s | RECEP, XLR 3P, MALE (for UC,EK) |
| | 1-509-184-51 | s | RECEP, XLR 3P, FEMALE (for J) |
| CN944 (TIME CODE IN) | 1-509-184-51 | s | RECEP, XLR 3P, FEMALE (for UC,EK) |
| | 1-509-176-51 | s | RECEP, XLR 3P, MALE (for J) |
| CN945 (CUE IN) | 1-509-184-51 | s | RECEP, XLR 3P, FEMALE (for UC,EK) |
| | 1-509-176-51 | s | RECEP, XLR 3P, MALE (for J) |
| CN946F (WFM MONITOR OUT) | 1-561-781-21 | s | RECEP, BNC, FEMALE |
| CN947F (WFM TRIGGER OUT) | 1-561-781-21 | s | RECEP, BNC, FEMALE |
| CN948F (SPARE 1) | 1-561-781-21 | s | RECEP, BNC, FEMALE |
| CN949F (SPARE 2) | 1-561-781-21 | s | RECEP, BNC, FEMALE |
| H1 | 8-825-770-01 | s | FULL ERASE HEAD |
| H2 | 8-825-770-01 | s | ERASE HEAD, CUE/CTL/TC |
| H3 | 8-825-770-12 | s | R/P HEAD, CUE/CTL/TC |
| M001 | 8-835-227-01 | s | MOTOR, DC, U-6A |
| M002 | 8-835-227-01 | s | MOTOR, DC, U-6A |
| M003 | 8-835-234-01 | s | MOTOR, DC, CAPSTAN BHF-1916A |
| M005 | 8-835-047-01 | s | MOTOR, DC, CASSETTE-UP COMPARTMENT MNR-4000A |
| M006 | 8-835-055-01 | s | MOTOR, DC, REEL POSITION DVR-4700A |
| M007 | 1-541-436-11 | s | FAN, DC12V |
| M008 | 1-541-437-12 | s | FAN, DC12V |
| M009 | 8-835-123-01 | s | MOTOR, DC, THREADING MNR-7400A |
| PM001 | 1-454-434-11 | s | SOLENOID, PLUNGER, PINCH |
| PM002 | 1-454-433-11 | s | SOLENOID, PLUNGER, T-REEL BREAK |
| PM003 | 1-454-433-11 | s | SOLENOID, PLUNGER, S-REEL BREAK |
| R1 | 1-214-865-00 | s | RES, CARBON 1.1K 1% 1/2W |
| R2 | 1-214-868-00 | s | RES, CARBON 1.5K 1% 1/2W |

(FRAME, DVR-1000)

| Ref. No. or Qty | Part No. | SP | Description |
|------------------------|-------------------------|----|----------------------------------|
| RV001 | 1-237-578-11 | s | POTENTIOMETER 5K |
| S1 | 1-578-572-11 | s | SWITCH, PUSH, POWER |
| S2 | 1-578-511-11 | s | SWITCH, ROCKER, VOLTAGE SELECTOR |
| S3 | 1-514-524-00 | s | SLIDE SWITCH |
| S4 | 1-514-524-00 | s | SLIDE SWITCH |
| R1 | 1-212-534-11 | s | RES, METAL 1.1K 1% 1/2W |
| R2 | 1-212-537-11 | s | RES, METAL 1.5K 1% 1/2W |
| W131 (to MB-137 board) | 1-562-746-11 | o | HOUSING, 13P |
| | 1-564-831-11 | o | TERMINAL |
| W132 (to MB-137 board) | 1-562-745-11 | o | HOUSING, 12P |
| | 1-564-831-11 | o | TERMINAL |
| W133 (to MB-137 board) | 1-562-748-11 | o | HOUSING, 15P |
| | 1-564-831-11 | o | TERMINAL |
| W134 (to MB-137 board) | 1-562-748-11 | o | HOUSING, 15P |
| | 1-564-831-11 | o | TERMINAL |
| W135 (to MB-137 board) | 1-562-747-11 | o | HOUSING, 14P |
| | 1-564-831-11 | o | TERMINAL |
| W413 (to BP-10 board) | 1-562-738-11 | o | HOUSING, 5P |
| | 1-564-831-11 | o | TERMINAL |

FRAME, DVR-1000/FUNCTION CONT. PNL.

| Ref. No. or Qty | Part No. | SP | Description |
|--------------------------|--------------|----|---|
| 1pc | 1-464-765-11 | s | DISPLAY UNIT, EL |
| 1pc | 1-515-618-11 | s | CLUTCH, ELECTROMAGNETIC |
| 1pc | 1-938-609-11 | o | FLAT CABLE ASSY, 16P/16P CPH-2 Include the following connectors. CN4F (to EL DISPLAY) CN503F (to SW-157 Board) |
| CN1F (to CP-106 board) | 1-562-151-11 | o | HOUSING, 6P |
| | 1-563-088-11 | o | CONTACT, FEMALE AWG24-30 |
| CN501F (to CP-106 board) | 1-563-883-11 | o | HOUSING, 30P |
| | 1-563-869-11 | o | CONTACT, FEMALE AWG26-30 |
| CN502F (to SW-157 board) | 1-563-883-11 | o | HOUSING, 30P |
| | 1-563-869-11 | o | CONTACT, FEMALE AWG26-30 |
| CN503F (to SW-157 board) | 1-563-876-11 | o | HOUSING, 16P |
| | 1-563-869-11 | o | CONTACT, FEMALE AWG26-30 Included in the flat cable assy CPH-2. |
| CN504F (to SW-157 board) | 1-562-627-11 | o | HOUSING, 13P |
| | 1-563-088-11 | o | CONTACT, FEMALE AWG24-30 |
| CN506F (to SW-157 board) | 1-562-627-11 | o | HOUSING, 13P |
| | 1-563-088-11 | o | CONTACT, FEMALE AWG24-30 |
| CN507F (to SW-157 board) | 1-563-880-11 | o | HOUSING, 24P |
| | 1-563-869-11 | o | CONTACT, FEMALE AWG26-30 |
| CN508F (to SW-158 board) | 1-562-151-11 | o | HOUSING, 6P |
| | 1-563-088-11 | o | CONTACT, FEMALE AWG24-30 |
| CN509F (to PS-138 board) | 1-563-880-11 | o | HOUSING, 24P |
| | 1-563-869-11 | o | CONTACT, FEMALE AWG26-30 |

ACCESSORIES SUPPLIED, DVR-1000

| Ref. No. or Qty | Part No. | SP | Description |
|--------------------|--------------|----|--|
| 1pc (for IC) | A-501-232-00 | s | CORD, POWER 3P |
| 1pc (for J) | A-504-754-00 | s | CORD, POWER 2P |
| 1pc (for EK) | A-501-232-00 | s | CORD, POWER |
| 2pcs | A-6001-012-A | o | ANGLE ASSY, RACK |
| 2pcs | 7-682-265-09 | s | SCREW +K 4X16 |
| 1pc | A-6001-011-A | s | EXTENSION BOARD, EX-129 (This assembly includes the following parts.) |
| 7pcs | 7-682-948-01 | s | SCREW +PSW3X8 |
| 12pcs | 7-622-205-05 | s | NUT M2 TYPE2 |
| 12pcs | 7-628-253-40 | s | SCREW +PS2X10 |
| CN1M | 1-506-748-11 | s | RECEP, DIN 96P, MALE |
| CN2M | 1-506-746-11 | s | RECEP, DIN 48P, MALE |
| CN3M | 1-506-746-11 | s | RECEP, DIN 48P, MALE |
| CN4F | 1-563-341-11 | s | RECEP, DIN 96P, FEMALE |
| CN5F | 1-563-339-11 | o | RECEP, DIN 48P, FEMALE |
| CN6F | 1-563-339-11 | o | RECEP, DIN 48P, FEMALE |

1pc A-6032-079-A o RS-232C PANEL ASSY
(This assembly includes the following parts.)

| | | | |
|------|--------------|---|---------------------|
| 2pcs | 3-576-921-00 | s | SPRING, COMPRESSION |
| 2pcs | 3-680-316-00 | s | NUT 4, STOPPER |
| 2pcs | 7-682-565-04 | s | SCREW, +B4x16 |
| 2pcs | 7-688-004-12 | s | W4, MIDDLE |

IF-210 BOARD, DVR-1000

The following components are included in the
RS-232C PANEL Assy: A-6032-079-

| | | | |
|------|--------------|---|-----------------------------|
| 2pcs | 7-662-207-05 | s | NUT 2.6, TYPE2 |
| 2pcs | 7-628-254-35 | s | SCREW +PS2.6x10 |
| 2pcs | 7-682-948-01 | s | SCREW +PSW3x8 |
| C1 | 1-126-153-11 | s | CAP. ELECT 22MF 20% 6.3V |
| C2 | 1-162-781-11 | s | CAP. CERAMIC 0.022µF 5% 50V |
| C3 | 1-162-781-11 | s | CAP. CERAMIC 0.022µF 5% 50V |
| C4 | 1-162-781-11 | s | CAP. CERAMIC 0.022µF 5% 50V |
| C5 | 1-162-781-11 | s | CAP. CERAMIC 0.022µF 5% 50V |
| C6 | 1-124-234-11 | s | CAP. ELECT 22µF 20% 16V |
| C7 | 1-124-234-11 | s | CAP. ELECT 22µF 20% 16V |
| C8 | 1-124-234-11 | s | CAP. ELECT 22µF 20% 16V |
| C9 | 1-124-234-11 | s | CAP. ELECT 22µF 20% 16V |
| C10 | 1-124-589-11 | s | CAP. ELECT 47µF 20% 16V |
| C11 | 1-124-589-11 | s | CAP. ELECT 47µF 20% 16V |
| CN1M | 1-506-746-11 | s | RECEP. DIN 48P, MALE |
| CN2 | 1-563-772-21 | s | RECEP, D-SUB 25P |
| FB1 | 1-535-178-00 | s | FERRITE BEAD |
| IC1 | 8-759-916-29 | s | IC SN74HC74N |
| IC2 | 8-759-202-89 | s | IC TC74HC139P |
| IC3 | 8-759-107-51 | s | IC CXQ71051P |
| IC4 | 8-759-014-25 | s | IC MC145146P |
| IC5 | 8-759-947-28 | s | IC DS1228 |
| IC6 | 8-759-202-12 | s | IC TC74HC02P |
| IC7 | 8-759-947-28 | s | IC DS1228 |
| IC8 | 8-759-917-05 | s | IC SN74HC541N |
| R1 | 1-249-423-11 | s | RES, CARBON 3.3K 5% 1/6W |
| RB1 | 1-235-005-00 | s | RESISTOR BLOCK, 47Kx8 |
| RB2 | 1-235-005-00 | s | RESISTOR BLOCK, 47Kx8 |
| RB3 | 1-235-359-11 | s | RESISTOR BLOCK, 47Kx4 |

OPTIONAL FIXTURE, DVR-1000

| Ref. No. or Qty | Part No. | SP | Description |
|--------------------|--------------|----|--|
| | J-6041-650-A | | TENSION ARM BENDING TOOL |
| | J-6041-670-A | | THICKNESS GAUGE |
| | J-6041-700-A | | ALLEN WRENCH SET, L-SHAPED HEX. |
| | J-6041-770-A | | IC TEST CLIP, TC-16 |
| | J-6041-780-A | | IC TEST CLIP, TC-20 |
| | J-6152-450-A | | WIRE CLEARANCE GAUGE SET |
| | J-6251-090-A | | TORQUE DRIVER BIT |
| | J-6251-110-A | | SCANNER ECCENTRICITY ADJ. GAUGE |
| | J-6251-120-A | | HEAD PROJECTION MEASUREMENT GAUGE |
| | J-6251-160-A | | GUIDE RAIL ADJ. TOOL |
| | J-6251-170-B | | REEL PLATE (M) |
| | J-6251-210-A | | PINCH ROLLER ADJ. TOOL |
| | J-6251-850-A | | PINCH ROLLER CHECK TOOL |
| | J-6251-870-A | | S-TENSION ARM OUTPUT CHECK TOOL |
| | J-6252-170-A | | CASSETTE FOR IN SWITCH "OFF" |
| | J-6252-180-A | | CASSETTE FOR IN SWITCH "ON" |
| | J-6252-190-A | | REEL TABLE HEIGHT ADJ. TOOL |
| | J-6252-200-A | | S-PLATE ADJ. TOOL |
| | J-6252-210-A | | HEAD TIP MICROSCOPE |
| | J-6252-300-A | | FLAT-PLATE |
| | J-6252-310-A | | PRT HARNESS GUIDE |
| | J-6252-360-A | | GUIDE S5 ZENITH CHECK TOOL |
| | J-6252-370-A | | GUIDE T6 ZENITH CHECK TOOL |
| | J-6252-380-A | | GUIDE S4 HEIGHT ADJ. TOOL |
| | J-6252-400-A | | REEL TABLE SHAFT ADJ. TOOL |
| | J-6252-510-A | | TORQUE DRIVER 6 kg-cm |
| | J-6252-520-A | | TORQUE DRIVER 12 kg-cm |
| | J-6252-530-A | | TORQUE DRIVER 26 kg-cm |
| | J-6252-540-A | | BITS SET FOR TORQUE DRIVER |
| | J-6252-730-A | | SLANT CHECK MASTER |
| | J-6253-420-A | | MICROSCOPE ATTACHMENT |
| | J-6263-470-A | | ROVING DAC |
| | J-6264-360-A | | BNC-UM CABLE |
| | Y-2031-001-0 | | CLEANING FLUIDE |
| | 1-559-042-21 | | CN-A CABLE ASSY, 2m |
| | 1-559-042-31 | | CN-A CABLE ASSY, 4m |
| | 1-559-936-11 | | CONTROL PANNEL CABLE 10m |
| | 2-034-697-00 | | CLEANING PIECE |
| | 2-379-736-02 | | PLATE, NUT |
| | 3-715-470-01 | | SPACER, SLANT GUIDE t=0.1 mm |
| | 3-715-470-11 | | SPACER, SLANT GUIDE t=0.05 mm |
| | 3-715-470-21 | | SPACER, SLANT GUIDE t=0.02 mm |
| | 3-715-470-31 | | SPACER, SLANT GUIDE t=0.01 mm |
| | 3-735-120-01 | | BRACKET |
| | 3-735-121-01 | | RAIL, SLIDE |
| | 3-735-152-01 | | BAND, CLEANING |
| | 7-662-001-41 | | MOLYTON GREASE No. 320 |
| | 7-662-001-62 | | SONY GREASE SGL-501 |
| | 7-700-733-01 | | ALIGNMENT SCREWDRIVER, SLOTTED HEAD |
| | 7-700-766-01 | | SCREWDRIVER, HEX, 0.89 mm |
| | 7-700-766-02 | | SCREWDRIVER, HEX, 1.4 mm |
| | 7-700-766-03 | | SCREWDRIVER, HEX, 2 mm |
| | 7-700-766-04 | | SCREWDRIVER, HEX, 2.5 mm |
| | 7-700-766-05 | | SCREWDRIVER, HEX, 3 mm |
| | 7-723-902-00 | | DENTAL MIRROR |
| | 8-960-070-01 | | ALIGNMENT TAPE, DR-5-1A |
| | 8-960-070-51 | | ALIGNMENT TAPE, DR-5-1B |

SECTION E
CHANGED PARTS

=====
UP TO #33199 (J)
UP TO #32199 (UC)
UP TO #32399 (EK)
=====

=====
#33201 & UP (J)
#33201 & UP (UC)
#32401 & UP (EK)
=====

SP-01 BOARD

| | | | | | | |
|-------|--------------|---|----------------|--------------|---|-----------------|
| ICA6 | 8-759-202-11 | s | IC TC74HC00P | 8-759-916-12 | s | IC SN74HC00N |
| ICA7 | 8-759-202-74 | s | IC TC74HC04P | 8-759-916-14 | s | IC SN74HC04N |
| ICA8 | 8-759-202-11 | s | IC TC74HC00P | 8-759-916-12 | s | IC SN74HC00N |
| ICA23 | 8-759-202-26 | s | IC TC74HC138P | 8-759-917-43 | s | IC SN74HC138N |
| ICB5 | 8-759-202-11 | s | IC TC74HC00P | 8-759-916-12 | s | IC SN74HC00N |
| ICB6 | 8-759-202-30 | s | IC TC74HC161P | 8-759-921-19 | s | IC SN74HC161N |
| ICB8 | 8-759-202-74 | s | IC TC74HC04P | 8-759-916-14 | s | IC SN74HC04N |
| ICB17 | 8-759-203-48 | s | IC TC74HC573P | 8-759-921-50 | s | IC SN74HC573N |
| ICB21 | 8-759-202-89 | s | IC TC74HC139P | 8-759-916-46 | s | IC SN74HC139N |
| ICB22 | 8-759-202-16 | s | IC TC74HC11P | 8-759-916-19 | s | IC SN74HC11N |
| ICB23 | 8-759-202-74 | s | IC TC74HC04P | 8-759-916-14 | s | IC SN74HC04N |
| ICC4 | 8-759-202-30 | s | IC TC74HC161P | 8-759-921-19 | s | IC SN74HC161N |
| ICC12 | 8-759-202-26 | s | IC TC74HC138P | 8-759-917-43 | s | IC SN74HC138N |
| ICC13 | 8-759-202-26 | s | IC TC74HC138P | 8-759-917-43 | s | IC SN74HC138N |
| ICC14 | 8-759-202-83 | s | IC TC74HC4538P | 8-759-038-14 | s | IC MC74HC4538AN |
| ICC23 | 8-759-202-30 | s | IC TC74HC161P | 8-759-921-19 | s | IC SN74HC161N |
| ICD13 | 8-759-203-48 | s | IC TC74HC573P | 8-759-921-50 | s | IC SN74HC573N |
| ICD15 | 8-759-202-26 | s | IC TC74HC138P | 8-759-917-43 | s | IC SN74HC138N |
| ICD16 | 8-759-202-26 | s | IC TC74HC138P | 8-759-917-43 | s | IC SN74HC138N |
| ICD20 | 8-759-202-55 | s | IC TC74HC244P | 8-759-916-71 | s | IC SN74HC244N |
| ICD21 | 8-759-202-93 | s | IC TC74HC153P | 8-759-921-17 | s | IC SN74HC153N |
| ICD23 | 8-759-202-21 | s | IC TC74HC32P | 8-759-916-25 | s | IC SN74HC32N |

SY-124 BOARD

| | | | | | | |
|-------|--------------|---|----------------|--------------|---|-----------------|
| ICB13 | 8-759-203-83 | s | IC TC74HC4538P | 8-759-038-14 | s | IC MC74HC4538AN |
|-------|--------------|---|----------------|--------------|---|-----------------|